

VICINITY MAP ZONE ATLAS PAGE K-11



UTILITY APPROVALS:

PUBLIC UTILITY EASEMENTS shown on this plat are granted for the common and joint use of:

APPROVED: [Signature] DATE 5-24-17
A. Public Service Company of New Mexico ("PNM"), a New Mexico corporation, (PNM Electric) for installation, maintenance, and service of overhead and underground electrical lines, transformers, other equipment and related facilities reasonably necessary to provide electrical services.

APPROVED: [Signature] DATE 5-18-17
B. New Mexico Gas Company for installation, maintenance, and service of natural gas lines, valves and other equipment and facilities reasonably necessary to provide natural gas services.

APPROVED: [Signature] DATE 5/23/2017
C. Qwest Corporation d.b.a. Century Link QC for the installation, maintenance and service of such lines, cable and other related equipment and facilities reasonably necessary to provide communication services.

APPROVED: [Signature] DATE 5/17/17
D. Comcast Cable for the installation, maintenance and service of such lines, cable, and other related equipment and facilities reasonably necessary to provide cable tv services.

INCLUDED, is the right to build, rebuild, construct, reconstruct, locate, relocate within the easement, change, remove, replace, modify, renew, operate, and maintain facilities for the purposes described above, together with free access to, from and over said easements, with the right and privilege of going upon, over and across adjoining lands of grantor for the purposes set forth herein and with the right to utilize the right of way and easement to extend services to customers of grantee, including sufficient working area space for electric transformers, with the right and privilege to trim and remove trees, shrubs or bushes which interfere with the purposes set forth herein. No building, sign, pool (aboveground or subsurface), hot tub, concrete or wood pool decking, or other structure shall be erected or constructed on said easements nor shall any well be drilled or operated thereon. Property owners shall be solely responsible for correcting any violations of National Electrical Safety Code by construction of pools, decking, or any structures adjacent to or near easements shown on this plat. Easements for electric transformers/switchgears, as installed, shall extend ten (10) feet in front of transformer/switchgear doors and five (5) feet on each side.

DISCLAIMER: In approving this plat, Public Service Company of New Mexico (PNM) and New Mexico Gas Company (NMGC) did not conduct a title search of the properties shown hereon. Consequently, PNM and NMGC do not waive or release any easement or easement rights which may have been granted by prior plat, replat or other document and which are not shown on this plat.

LEGAL DESCRIPTION:

Tract "C-15-A", as shown and designated on the plat entitled "Plat of Tracts C-15-A and C-15-B, TOWN OF ATRISCO GRANT, UNIT 2, Proj. Section 23, T.10N., R.2E., N.M.P.M., Albuquerque, New Mexico, February 2000", filed in the office of the County Clerk of Bernalillo County, New Mexico on October 19, 2000 in Plat Book 2000C, Page 277.

FREE CONSENT:

The undersigned owner(s) do hereby consent to the platting of said property as shown hereon and the same is with their free consent and in accordance with their desires. The undersigned individuals hereby represent themselves as authorized to so act. The undersigned hereby grant the easement(s) as shown and noted hereon. The undersigned warrant that they hold among them complete and indefeasible title in fee simple to the subdivided property.

[Signature] Leticia Jaquez
Cosme Jaquez Leticia A. Jaquez

ACKNOWLEDGEMENT

State of New Mexico)
County of Bernalillo)ss

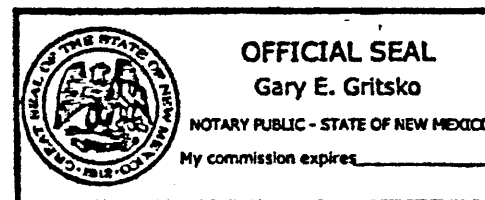

This instrument was acknowledged before me on May 15, 2017.

BY: Cosme Jaquez, Leticia A. Jaquez
My Commission expires: 7/21/2020 [Signature]
Notary Public

SURVEYOR'S CERTIFICATE:

I, Gary E. Gritsko, a duly qualified New Mexico Professional Surveyor under the laws of the State of New Mexico, do hereby certify that this plat was prepared by me or under my supervision, that it shows all easements as shown on the plat of record or made known to me by the owners of the subdivision shown hereon, utility companies and other parties expressing an interest and that it meets the minimum requirements for monumentation and surveys of the Albuquerque Subdivision Ordinance, and further that it meets the Minimum Standards for Land Surveying in the State of New Mexico, and is true and correct to the best of my knowledge and belief.

[Signature] Gary E. Gritsko, N.M.P.S. No. 8686
April 10, 2017
Date



COUNTY CLERK RECORDING STAMP

DOCH 2017067116
07/12/2017 10:28 AM Page: 1 of 2
PLAT R:\$25.00 B: 2017C P: 0081 Linda Stover, Bernalillo County

VACATION OF EASEMENT PLAT
Tract C-15-A, Unit 2
TOWN OF ATRISCO GRANT
within the Town of Atrisco Grant
projected Section 23, T.10N., R.2E., N.M.P.M.
City of Albuquerque, Bernalillo County, New Mexico
April 2017

PURPOSE OF PLAT:

The purpose of this plat is vacate an existing public utility easement.

CITY OF ALBUQUERQUE DEVELOPMENT REVIEW BOARD APPROVALS:

PROJECT NO. 1000423 APPLICATION NO. 17DRB-70129

[Signature] 7-5-17
DRB CHAIRPERSON, PLANNING DEPARTMENT DATE

[Signature] 6/21/17
PARKS & RECREATION DEPARTMENT DATE

[Signature] 06-21-17
A.B.C.W.U.A. DATE

[Signature] 6/21/17
A.M.A.F.C.A. DATE

[Signature] 6/21/17
CITY ENGINEER DATE

[Signature] 7/3/17
TRAFFIC ENGINEERING DATE

[Signature] P.S. 5/18/17
CITY SURVEYOR DATE

BERNALILLO COUNTY TREASURER'S CERTIFICATE:

THIS IS TO CERTIFY THAT TAXES ARE CURRENT & PAID ON

UPC#: 1-011-057-105310-20602
[Signature] PROPERTY OWNER OF RECORD
[Signature] 7-12-17
Bernalillo County Treasurer Date

DOCH 2017067116

07/12/2017 10:28 AM Page: 2 of 2
 PLAT R:\$25.00 B: 2017C P: 0081 Linda Stover, Bernalillo County

VACATION OF EASEMENT PLAT
 Tract C-15-A, Unit 2
 TOWN OF ATRISCO GRANT
 within the Town of Atrisco Grant
 projected Section 23, T.10N., R.2E., N.M.P.M.
 City of Albuquerque, Bernalillo County, New Mexico
 April 2017

SURVEY AND SUBDIVISION NOTES:

- Bearings are based on NM State Plane grid bearings, Central zone, NAD83, rotated at AGRS Control Station 7_K10.
- Distances are horizontal ground distances in US survey feet.
- Bearings and distances in parenthesis () are record measurements, where record data differs from measured data.
- This plat shows all easements of record made known to this surveyor.
- Gross subdivision area: 1.2032 acres, more or less
- Number of existing lots: 1
- Number of lots created: 0
- FLOOD ZONE: The property shown hereon is located in Zone AH (EL 5076), areas within the 1.0% annual chance flood plain, according to the FEMA Flood Insurance Rate Map of Bernalillo County, New Mexico, Panel No. 35001C0329H, effective date August 16, 2012.
- SOLAR RESTRICTIONS: No property within the area of requested final action shall at any time be subject to a deed restriction, covenant or binding agreement prohibiting solar collectors from being installed on buildings or erected on the lots or parcels within the area of proposed plat. The foregoing requirement shall be a condition to approval of this plat or site development plan for subdivision. (Section 14-14-4-7)
- Reference documents:
 - Plat of Town of Atrisco Grant, filed 10/19/2000, Bk. 2000C, Pg 277.
 - Plat of Casa Blanca Addition, filed 12/29/1945, Bk. D, Pg. 84.
 - Plat of Van Barber, filed 4/05/1983, Bk. C21, Pg. 29.



AGRS STATION "7_K10"
 NM STATE PLANE COORDINATES
 N=1483739.165, E=1498962.651
 CENTRAL ZONE (NAD 83)
 G-G FACTOR: 0.999683006
 MAPPING ANGLE: -0°16'18.14"
 ELEVATION: 5097.854' (NAVD88)

MONUMENT LEGEND

- △ - FOUND CONTROL STATION AS NOTED
- - FOUND MONUMENT AS NOTED
- - SET 1/2" REBAR W/PLASTIC CAP STAMPED "G.GRITSKO PS8686", UNLESS OTHERWISE NOTED

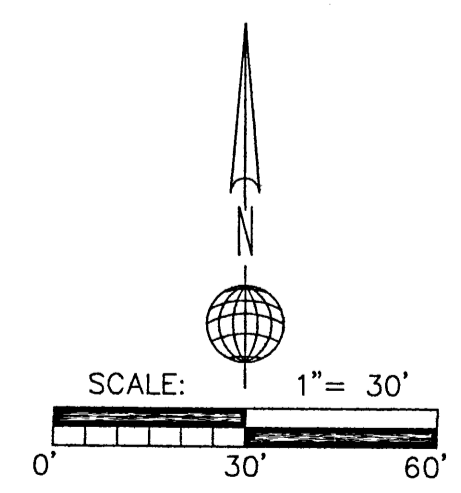

ALPHA PRO SURVEYING LLC
 1436 32ND CIRCLE SE, RIO RANCHO, NEW MEXICO 87124
 PHONE (505) 892-1076 ALPHAPROSURVEYING.COM
 DRAWN BY: GG FILE No.:17-031