

1 GRADE LEVEL PARKING PLAN
1/16" = 1'-0"

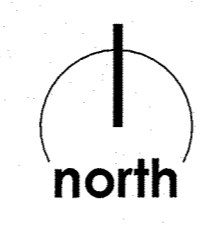

	Spaces
Grade Level	146 SP (including 4 ADA)
Level P1	494 SP
Level P2	318 SP
Total:	958 SP

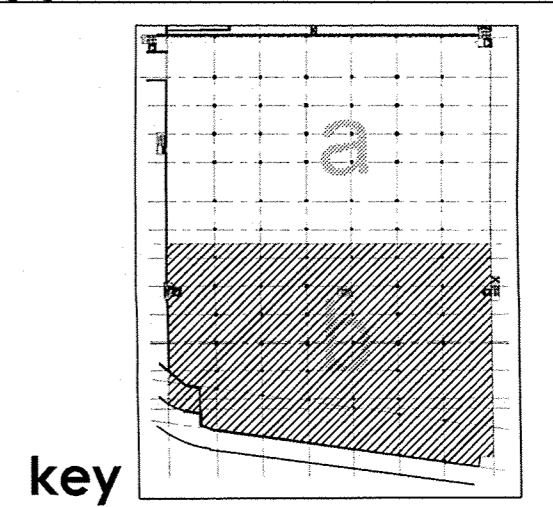

MODULUS ARCHITECTS
 220 COPPER AVE. N.W. SUITE 350
 ALBUQUERQUE, NEW MEXICO 87102
 PHONE (505) 338-1499 FAX (505) 338-1498

PROJECT TITLE	WINROCK SECTION 2
PROJECT MANAGER	WINROCK TOWN CENTER ALBUQUERQUE NEW MEXICO
JOB NO.	PDM X
DRAWN BY:	MAJS
DATE:	02/01/15
SCALE:	1/16" = 1'-0"
SHEET TITLE	STRIPING PLAN
SHEET NO.	F1.0B

REV	DATE	BY	REVISION
1			
2			
3			
4			
5			
6			

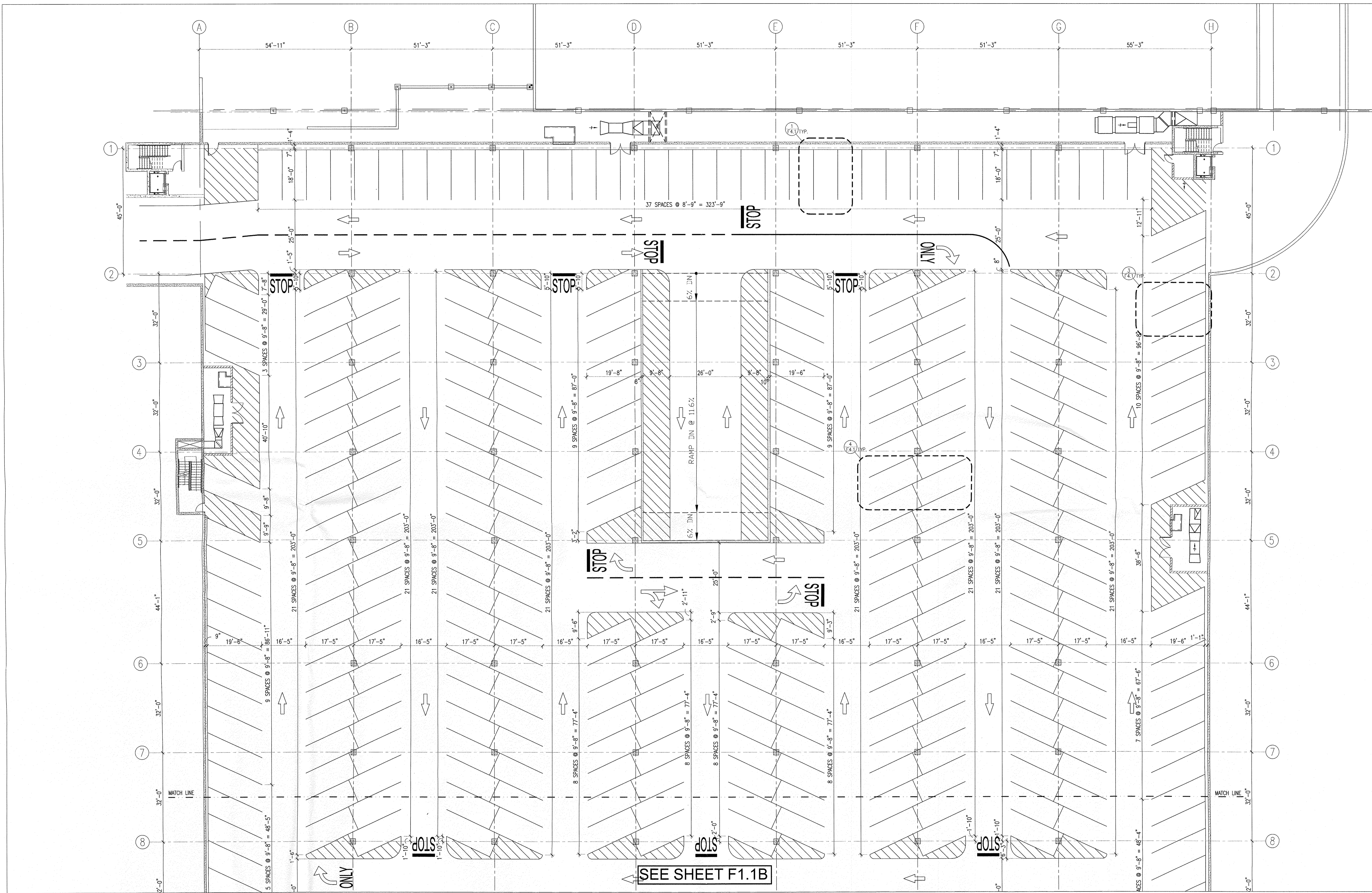

1 PARKING LEVEL P1 PLAN - NORTH AREA
1/16" = 1'-0"

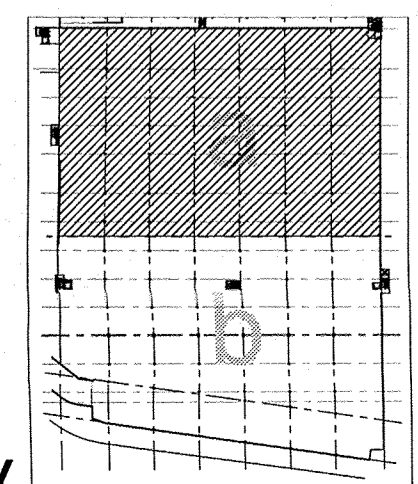

key

REV	DATE	BY	REVISION
A			
B			
C			
D			
E			

MODULUS ARCHITECTS
 220 COPPER AVE. N.W. SUITE 350
 ALBUQUERQUE, NEW MEXICO 87102
 PHONE (505) 338-1499 FAX (505) 338-1498

PROJECT TITLE	WINROCK SECTION 2
PROJECT MANAGER	WINROCK TOWN CENTER ALBUQUERQUE, NEW MEXICO
PROJECT NO.	X
DRAWN BY:	MJS
SHEET TITLE	STRIPING PLAN

DATE	02/01/15
SCALE	1/16" = 1'-0"
SHEET NO.	F1.1A

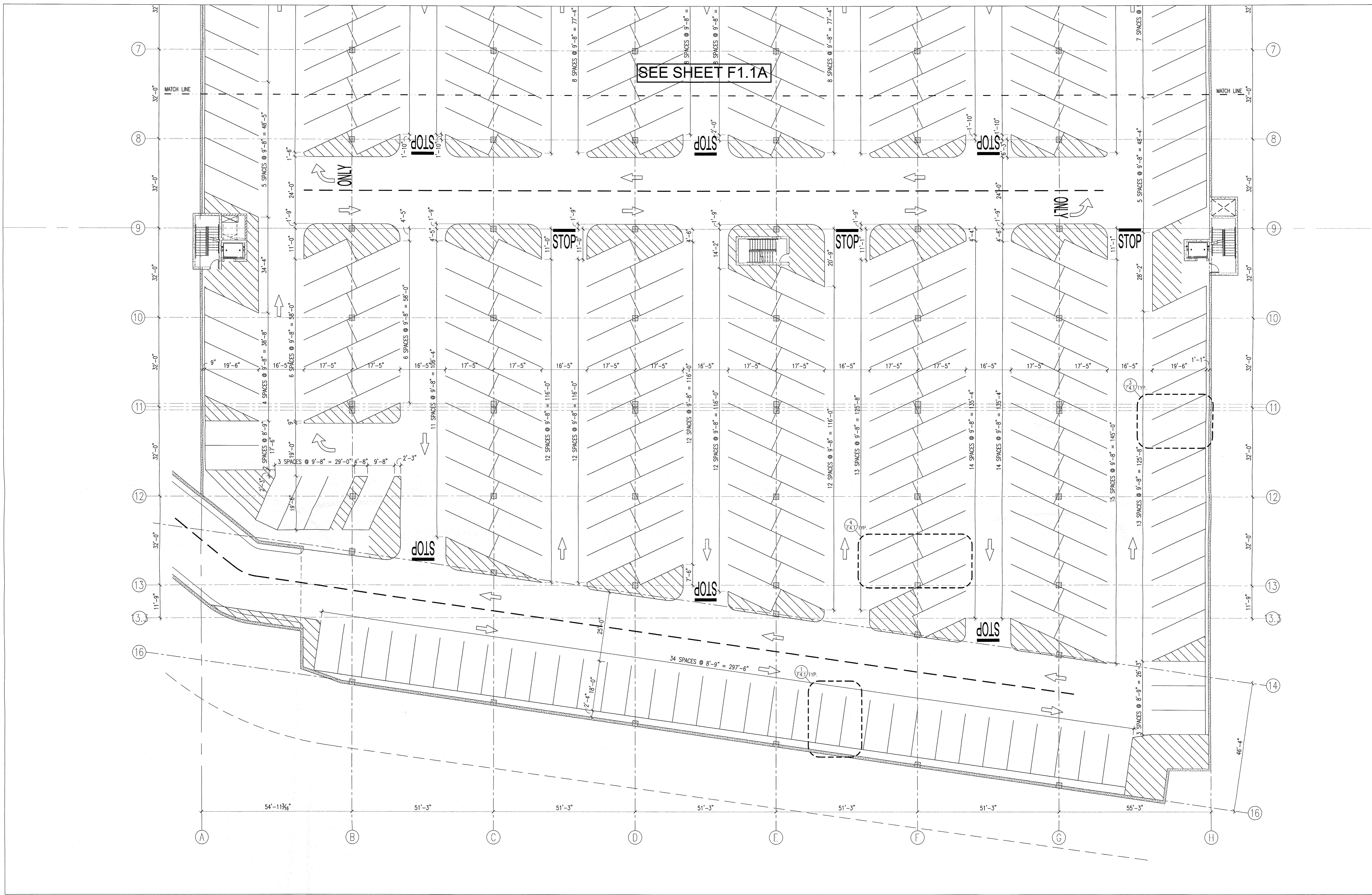

1 PARKING LEVEL P1 PLAN - SOUTH AREA
1/16" = 1'-0"

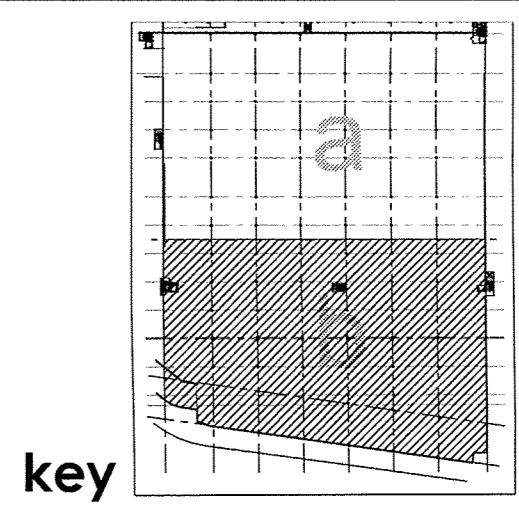
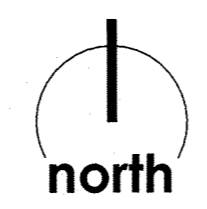

key

REV	DATE	BY	REVISION
1			
2			
3			
4			
5			

MODULUS ARCHITECTS
 220 COPPER AVE. N.W. SUITE 350
 ALBUQUERQUE, NEW MEXICO 87102
 PHONE (505) 338-1499 FAX (505) 338-1498

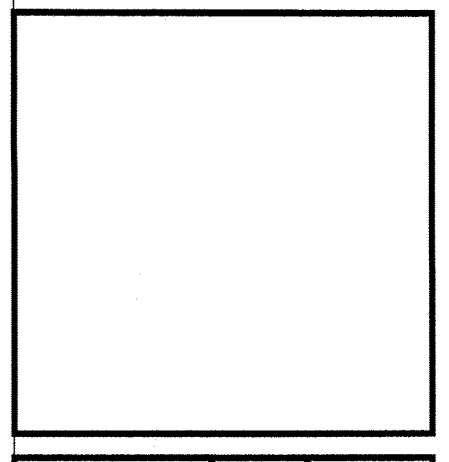

PROJECT TITLE	WINROCK SECTION 2 WINROCK TOWN CENTER ALBUQUERQUE, NEW MEXICO
PROJECT MANAGER	POJ
JOB NO.	X
DRAWN BY:	MJS
SHEET TITLE	STRIPING PLAN
DATE	02/01/15
SCALE	1/16" = 1'-0"
SHEET NO.	F1.1B

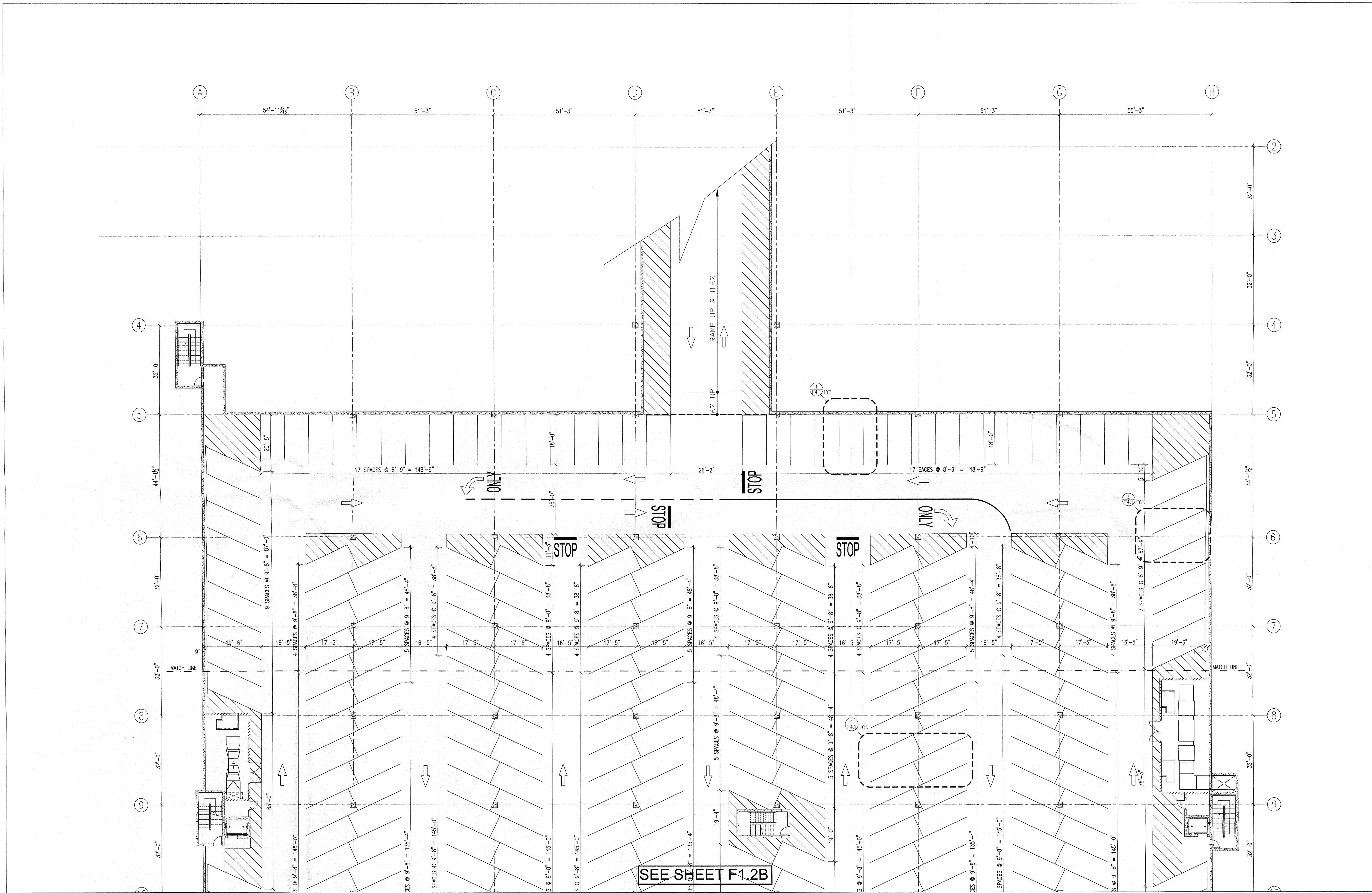

1 PARKING LEVEL P2 PLAN - NORTH AREA
1/16" = 1'-0"

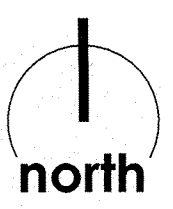

SEE SHEET F1.2B

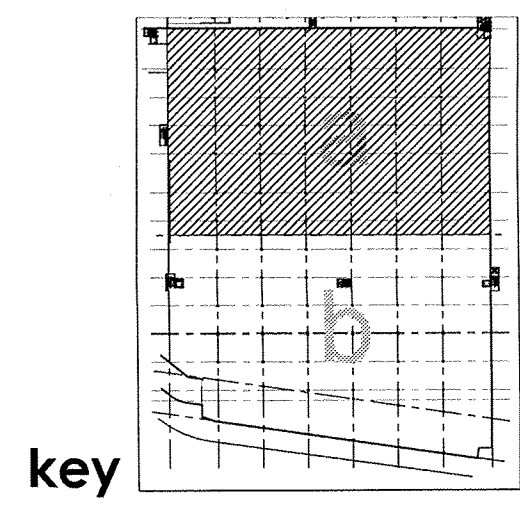

key

REV	DATE	BY	REVISION
A			
B			
C			
D			
E			

MODULUS ARCHITECTS
 220 COPPER AVE. N.W. SUITE 350
 ALBUQUERQUE, NEW MEXICO 87102
 PHONE (505) 338-1499 FAX (505) 338-1498

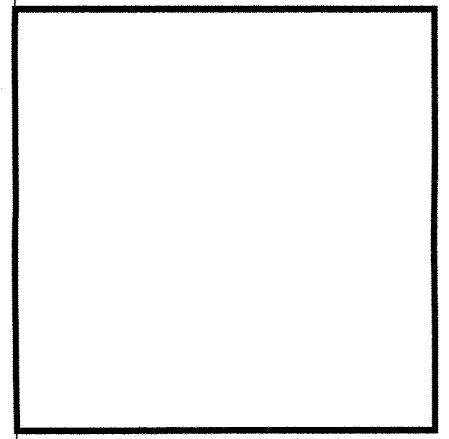

PROJECT TITLE WINROCK SECTION 2 WINROCK TOWN CENTER ALBUQUERQUE NEW MEXICO	JOB NO. X	DRAWN BY: MJS
PROJECT MANAGER PDV	SHEET TITLE STRIPING PLAN	

DATE 02/01/15	sheet F1.2A
SCALE 1/16" = 1'-0"	of

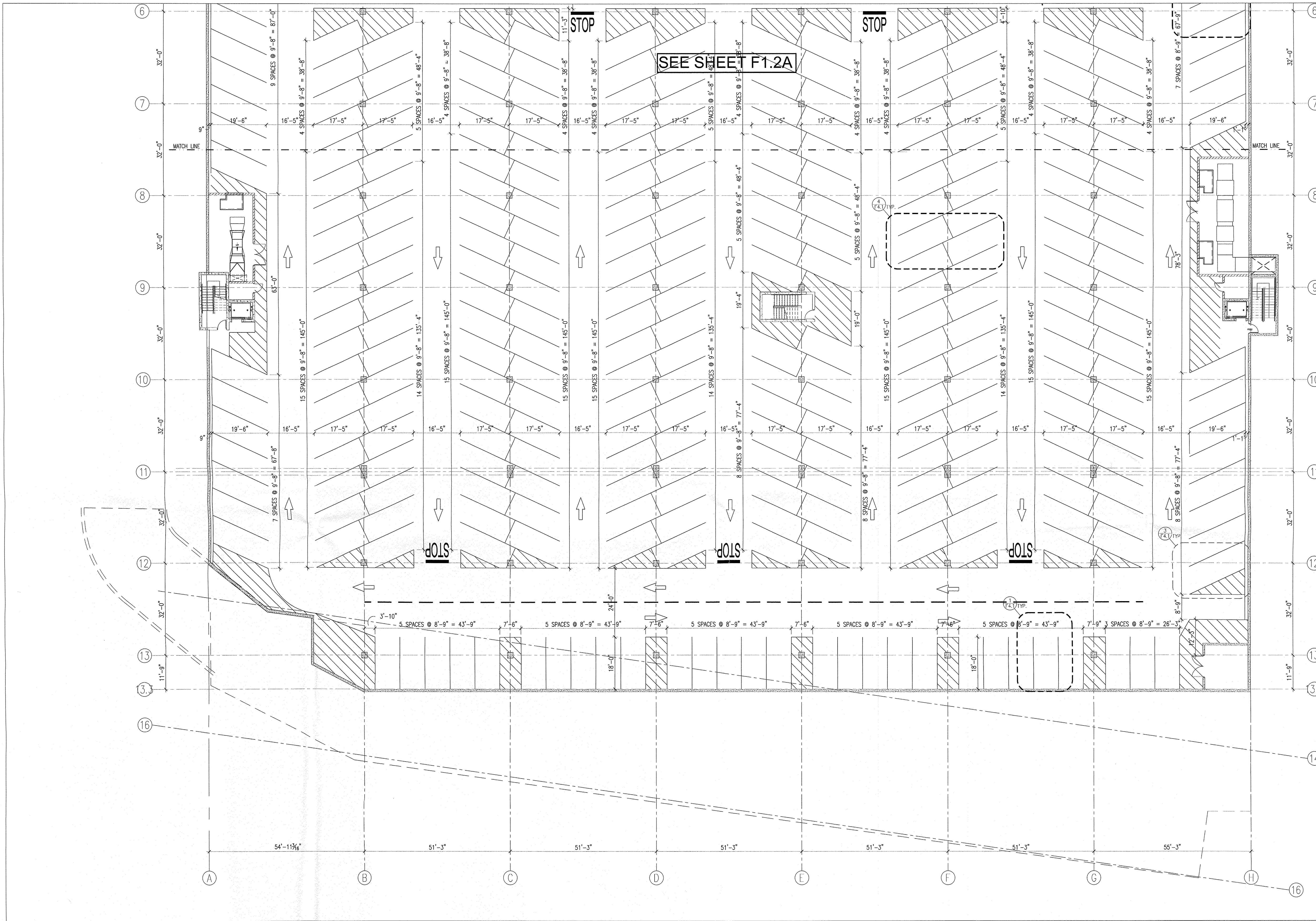

1 PARKING LEVEL P2 PLAN - SOUTH AREA
1/16" = 1'-0"

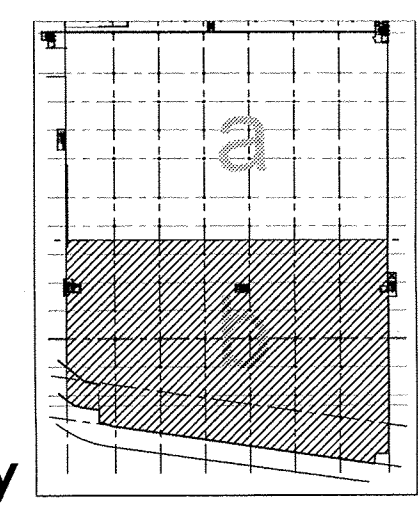

key

REV	DATE	BY	REVISION
1			
2			
3			
4			
5			
6			

MODULUS ARCHITECTS
 220 COPPER AVE. N.W. SUITE 350
 ALBUQUERQUE, NEW MEXICO 87102
 PHONE (505) 338-1499 FAX (505) 338-1498

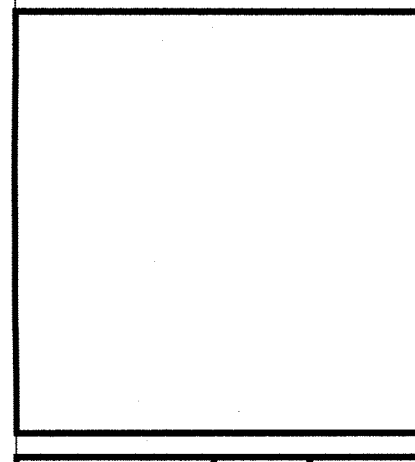

PROJECT TITLE WINROCK SECTION 2 WINROCK TOWN CENTER ALBUQUERQUE NEW MEXICO	JOB NO. X	DRAWN BY: MJS
PROJECT MANAGER PDV	SHEET TITLE STRIPING PLAN	
DATE 02/01/15	sheet F1.2B	
SCALE 1/16"=1'-0"	pt.	

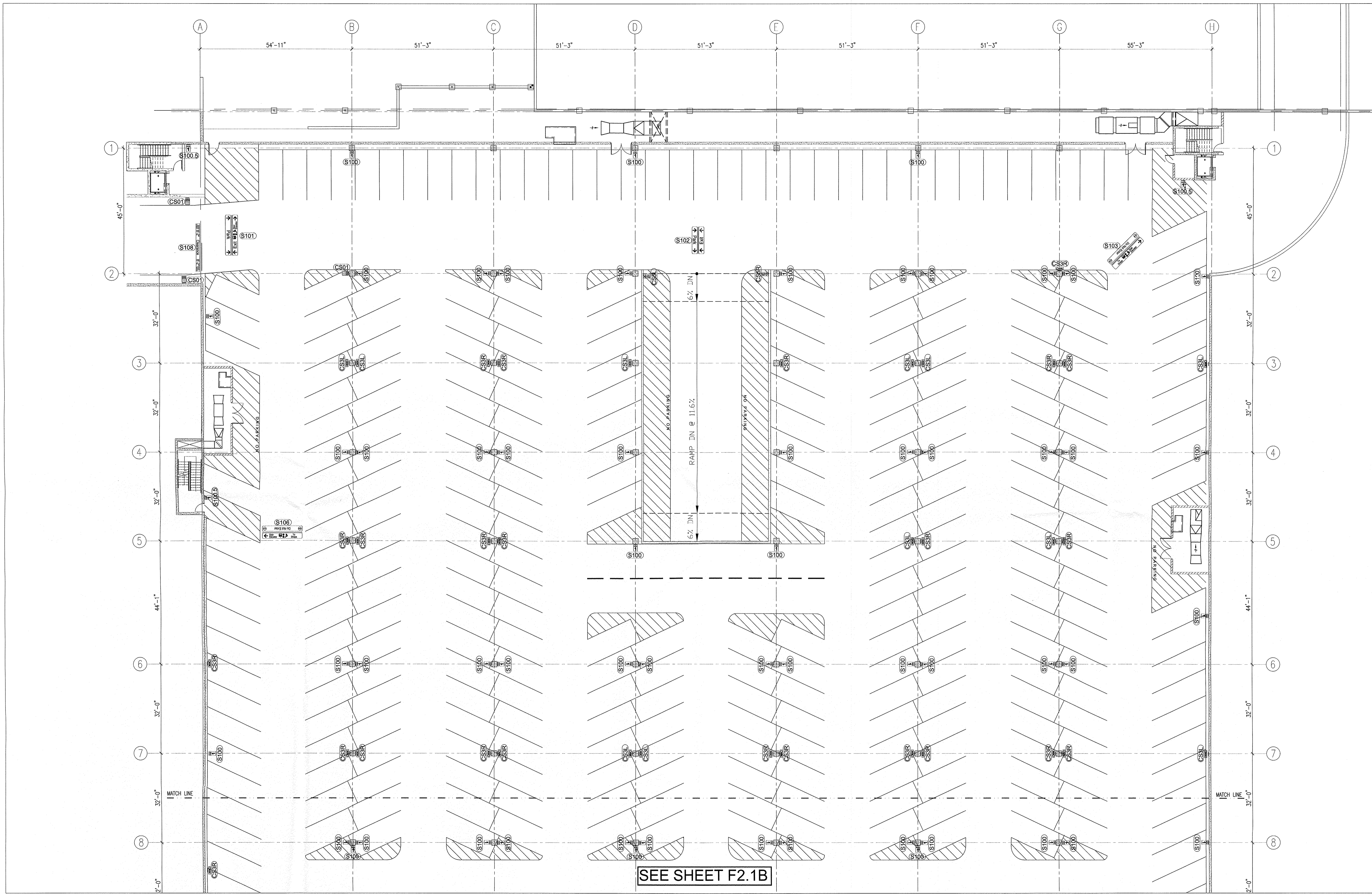

1 PARKING LEVEL P1 PLAN - NORTH AREA
1/16" = 1'-0"



- KEY
- (SXX) SIGN MARK, SEE SCHEDULE, SHEET F4.2
 - (CSXX)

SEE SHEET F2.1B

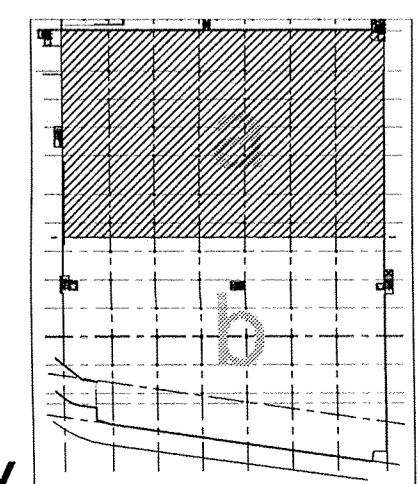

key

REV	DATE	BY	REVISION
1			
2			
3			
4			
5			

MODULUS ARCHITECTS
 220 COPPER AVE. N.W. SUITE 350
 ALBUQUERQUE, NEW MEXICO 87102
 PHONE (505) 338-1499 FAX (505) 338-1498

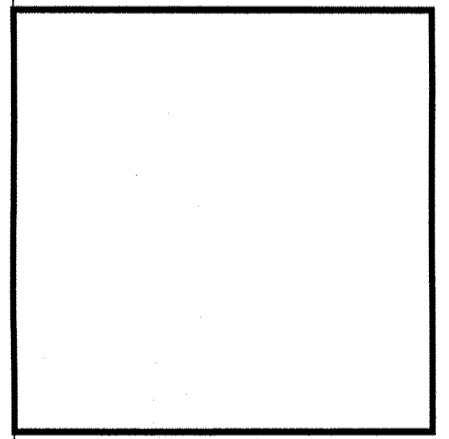

PROJECT TITLE	WINROCK SECTION 2
PROJECT MANAGER	WINROCK TOWN CENTER
DATE	ALBUQUERQUE, NEW MEXICO
SCALE	1/16" = 1'-0"
JOB NO.	X
DRAWN BY:	MUS
SHEET TITLE	SIGNAGE PLAN
DATE	02/01/15
SCALE	1/16" = 1'-0"
SHEET NO.	F2.1A

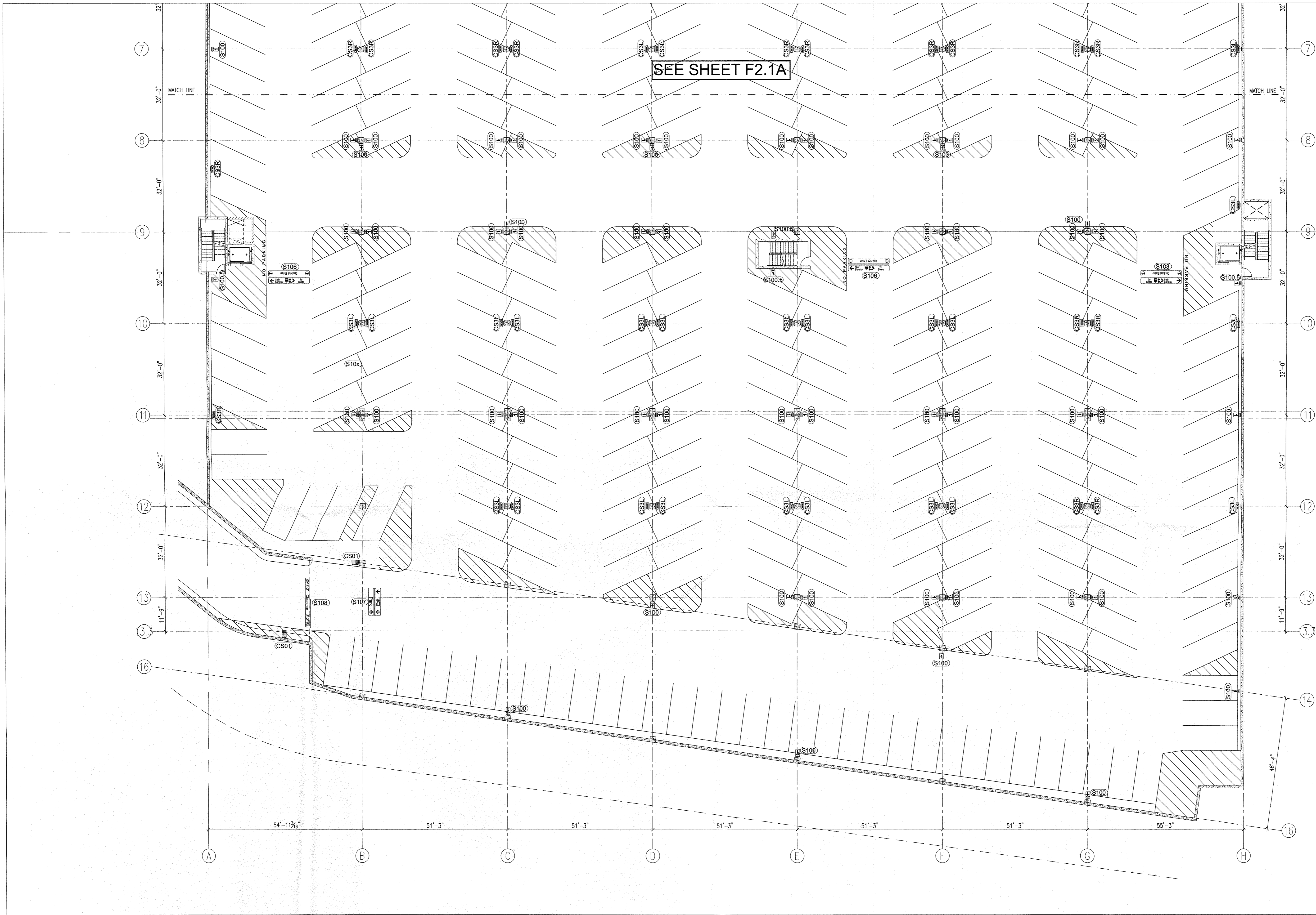

1 PARKING LEVEL P1 PLAN - SOUTH AREA
1/16" = 1'-0"



- KEY**
- SXX SIGN MARK, SEE SCHEDULE, SHEET F4.2
 - CSXX

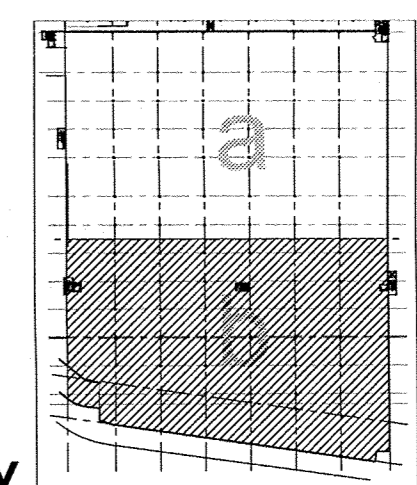

key

REV	DATE	BY	REVISION
1			
2			
3			
4			
5			

MODULUS ARCHITECTS
 220 COPPER AVE. N.W. SUITE 350
 ALBUQUERQUE, NEW MEXICO 87102
 PHONE (505) 338-1499 FAX (505) 338-1498

PROJECT TITLE	WINROCK SECTION 2
PROJECT MANAGER	WINROCK TOWN CENTER ALBUQUERQUE NEW MEXICO
JOB NO.	X
DRAWN BY:	MJS
DATE	02/01/15
SCALE	1/16" = 1'-0"
SHEET TITLE	SIGNAGE PLAN
SHEET NO.	F2.1B

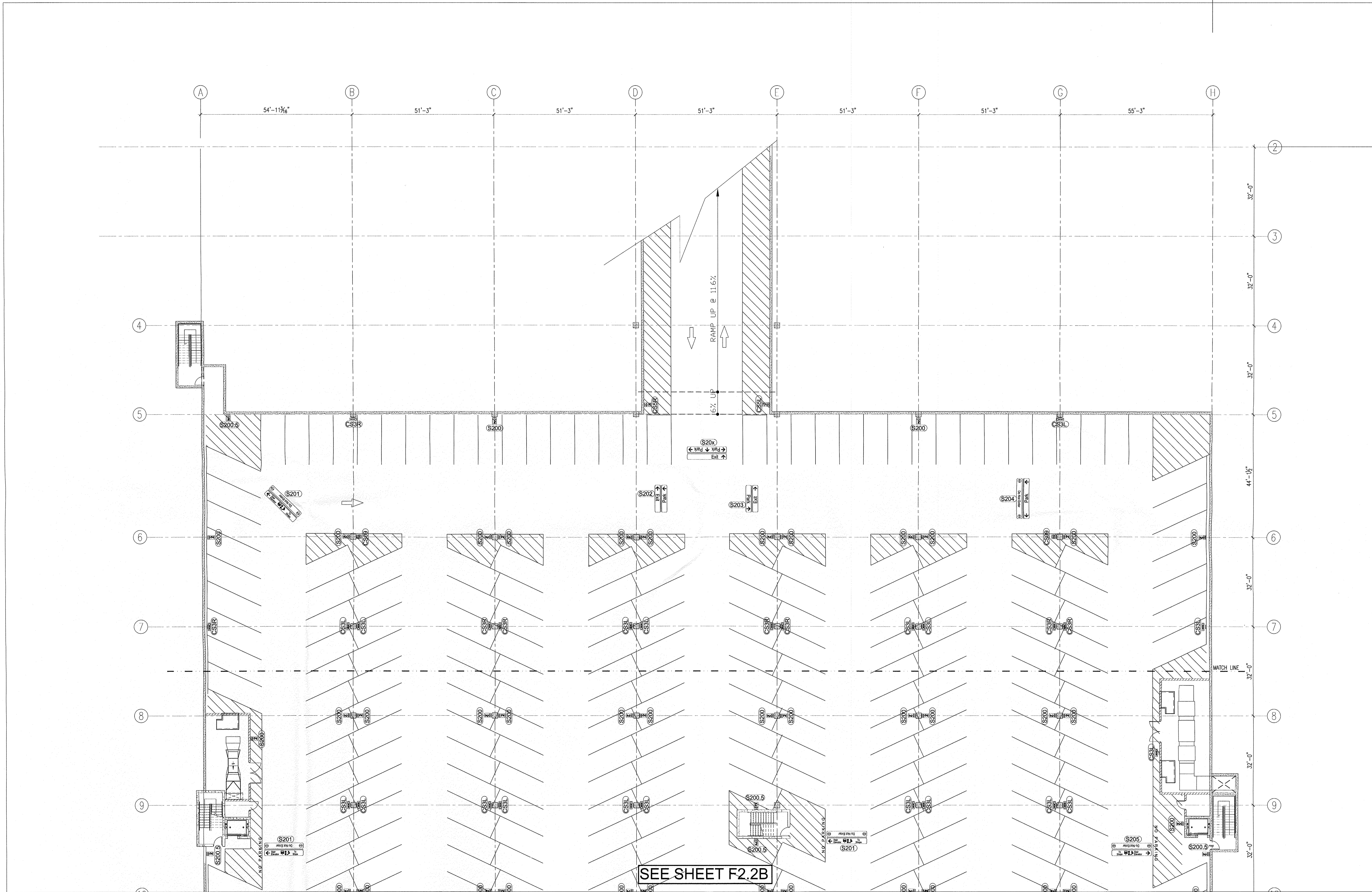

1 PARKING LEVEL P2 PLAN - NORTH AREA
1/16" = 1'-0"



KEY
 SXX SIGN MARK, SEE SCHEDULE, SHEET F4.2
 CSXX SIGN MARK, SEE SCHEDULE, SHEET F4.2

SEE SHEET F2.2B

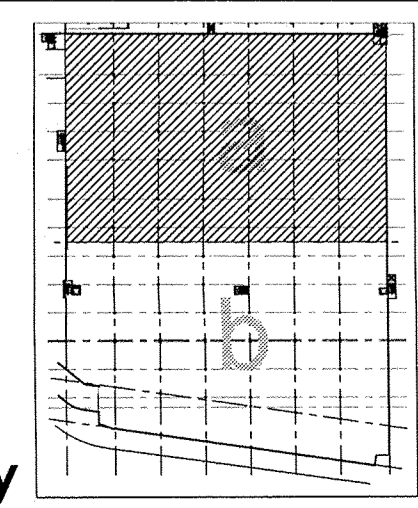

key

REV	DATE	BY	REVISION
1			
2			
3			
4			
5			

MODULUS ARCHITECTS
 220 COPPER AVE. N.W. SUITE 350
 ALBUQUERQUE, NEW MEXICO 87102
 PHONE (505) 338-1499 FAX (505) 338-1498

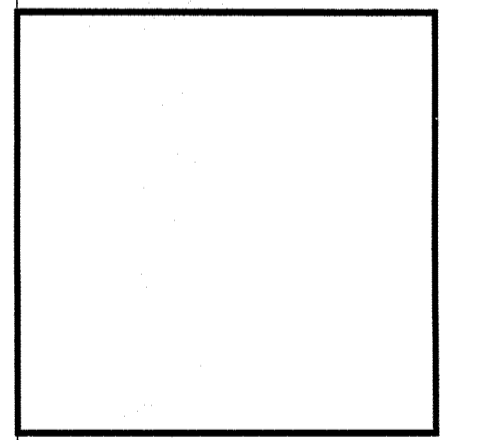

PROJECT TITLE	WINROCK SECTION 2 WINROCK TOWN CENTER ALBUQUERQUE NEW MEXICO
PROJECT MANAGER	PDM X
DRAWN BY:	MJS
SHEET TITLE	SIGNAGE PLAN

DATE:	02/01/15
SCALE:	1/16" = 1'-0"
SHEET NO.	F2.2A

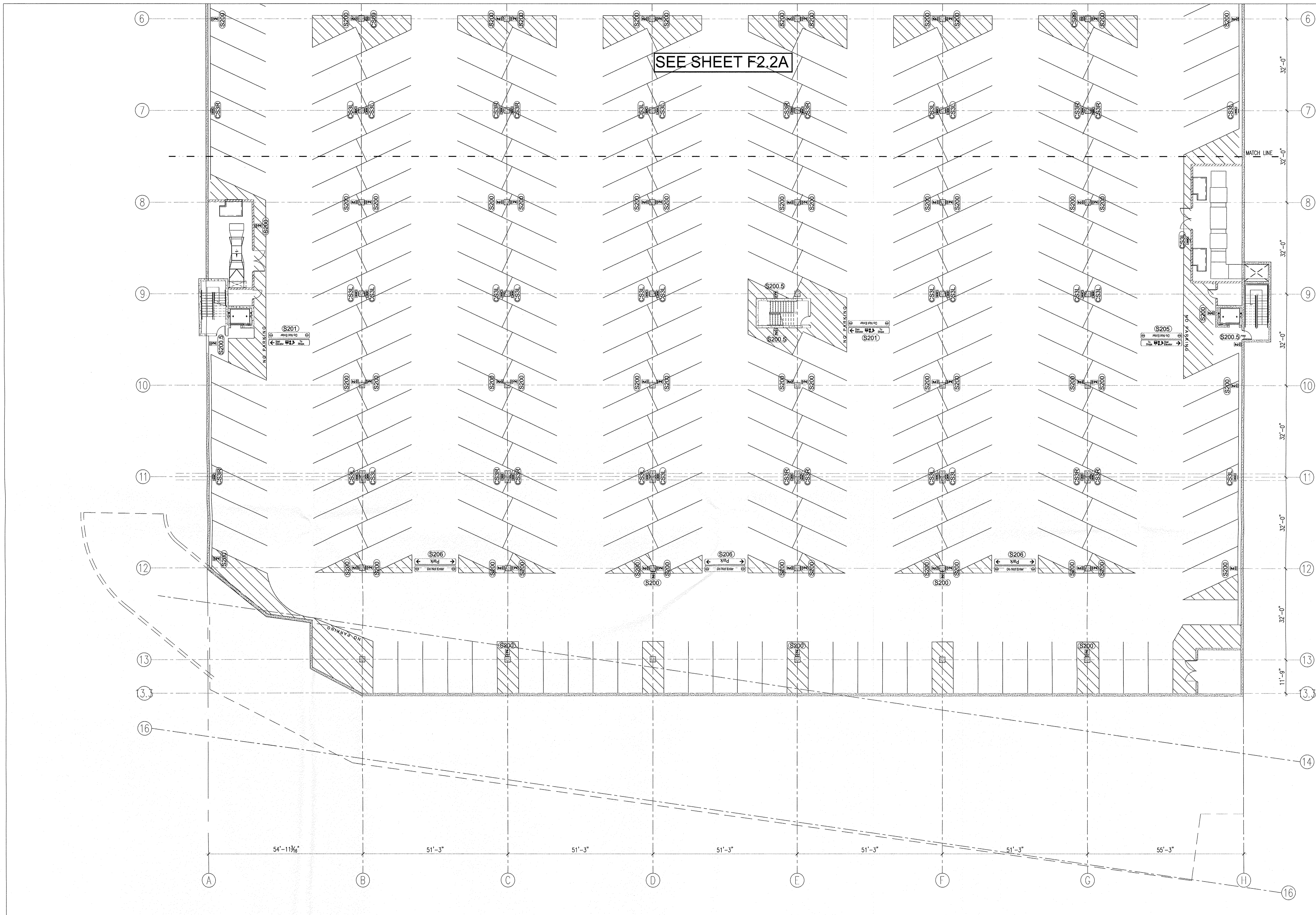

1 PARKING LEVEL P2 PLAN - SOUTH AREA
1/16" = 1'-0"



KEY
 (SXX) SIGN MARK, SEE SCHEDULE, SHEET F4.2
 (CSXX)

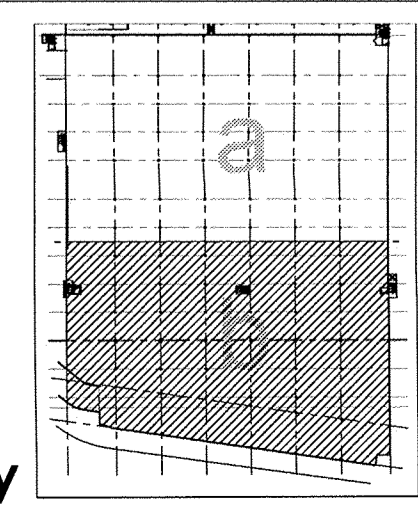

key

REV	DATE	BY	REVISION
1			
2			
3			
4			
5			

MODULUS ARCHITECTS
 220 COPPER AVE. N.W. SUITE 350
 ALBUQUERQUE, NEW MEXICO 87102
 PHONE (505) 338-1499 FAX (505) 338-1498

PROJECT TITLE WINROCK SECTION 2 WINROCK TOWN CENTER ALBUQUERQUE NEW MEXICO	JOB NO. X	DRAWN BY: MJS
PROJECT MANAGER PDV	SHEET TITLE SIGNAGE PLAN	
DATE 02/01/5	sheet: F2.2B	
SCALE 1/16"=1'-0"	pt.	

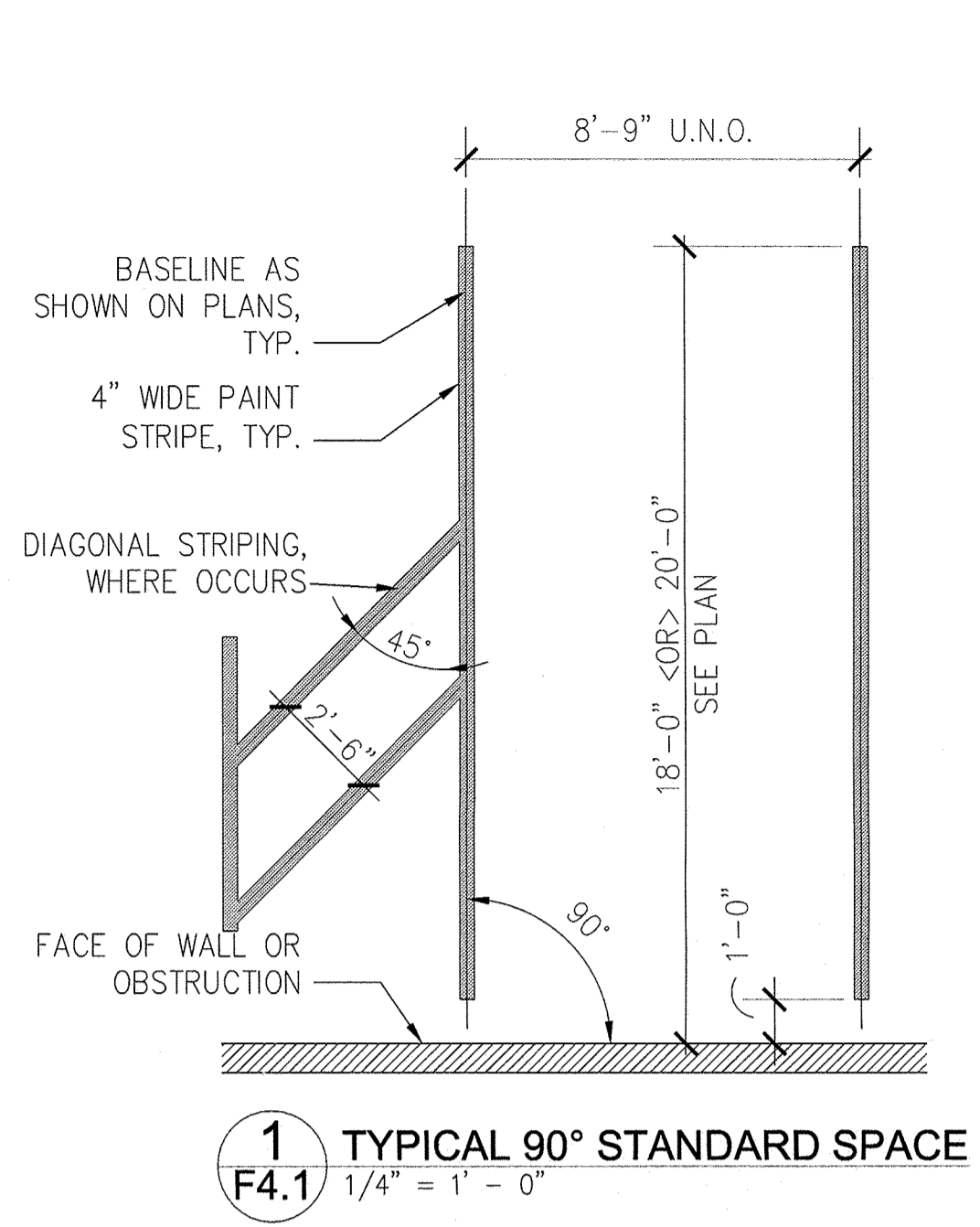

1 TYPICAL 90° STANDARD SPACE
F4.1 1/4" = 1' - 0"

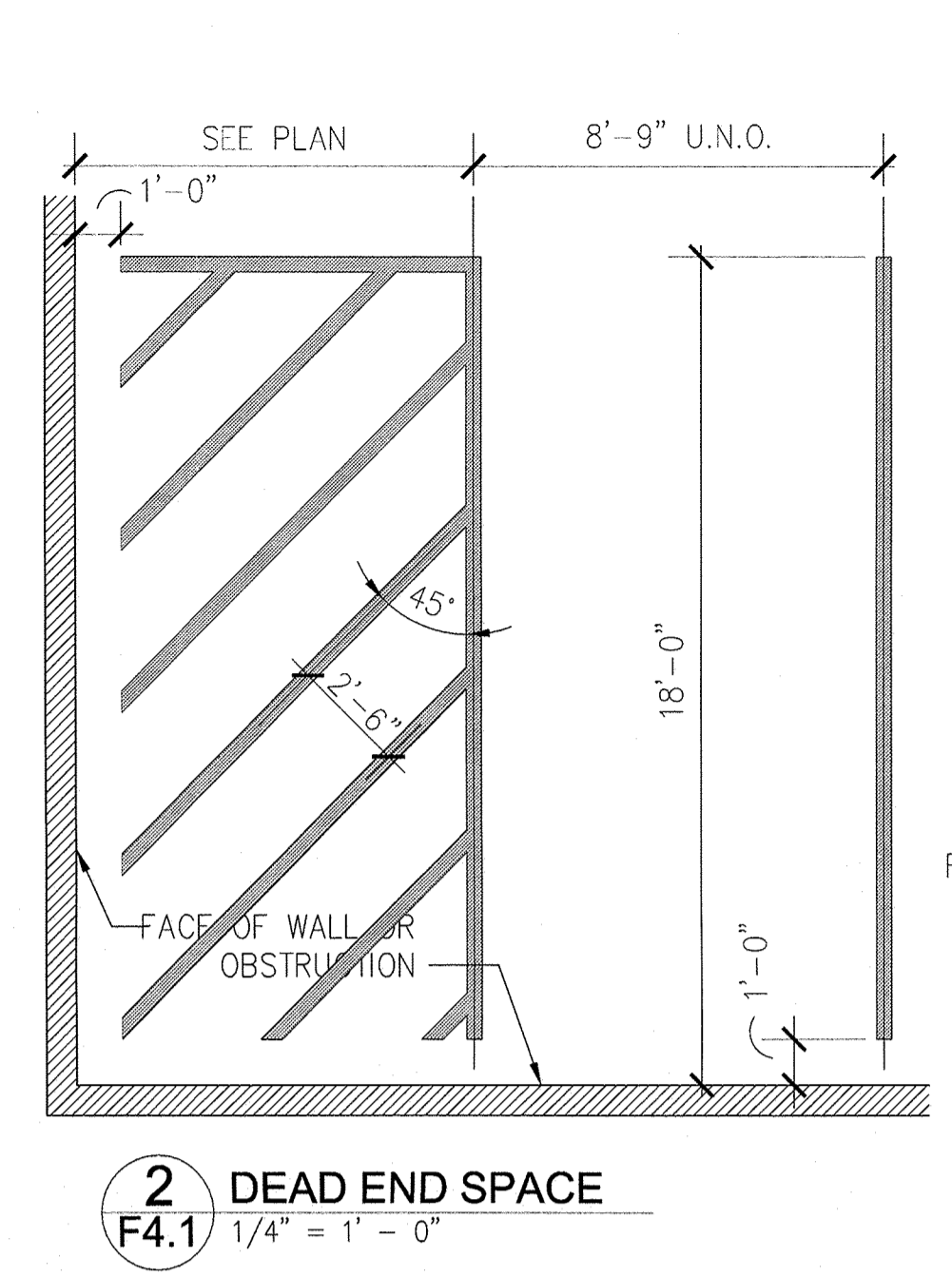

2 DEAD END SPACE
F4.1 1/4" = 1' - 0"

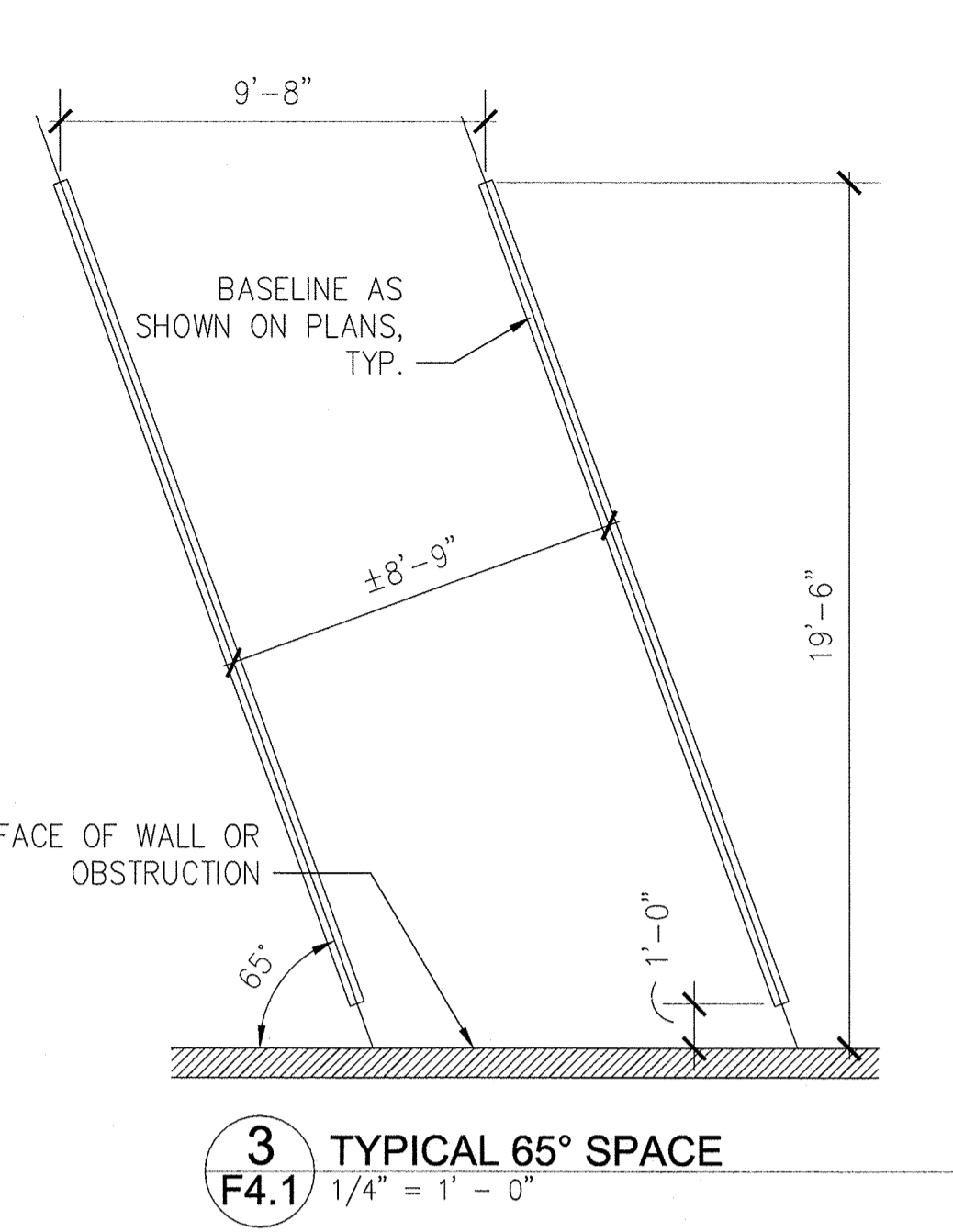

3 TYPICAL 65° SPACE
F4.1 1/4" = 1' - 0"

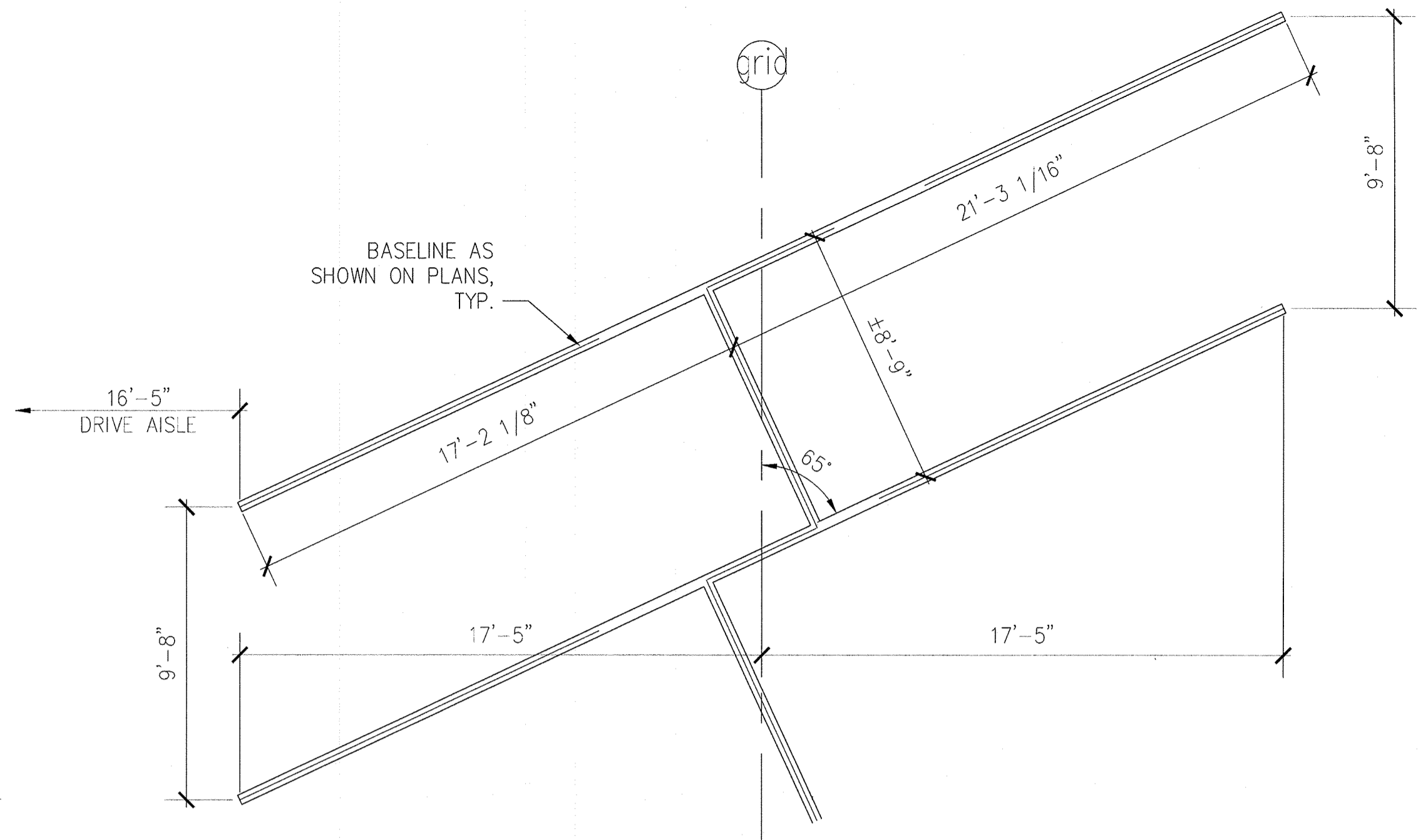

4 TYPICAL 65° INTERLOCK SPACE
F4.1 1/4" = 1' - 0"

STRIPING NOTES:
ALL FLOOR STRIPES ARE 4" WIDE. SEE PROJECT MANUAL FOR COLOR.
BLOCKED OUT AREAS ARE TO BE DIAGONALLY STRIPED WITH 4" WIDE STRIPES AT 2'-6" O.C.
SEE PLAN SHEETS (F 1.X SERIES) FOR STRIPING LAYOUT.



7 MARKING DETAILS
F4.1 1/4" = 1' - 0"
NOTES: OVERALL DIMENSIONS TYP. FOR SINGLE WORD PAVEMENT MARKINGS.
USE WHITE EVER-BRITE (CALAPHOTE INC.) OR APPROVED EQUAL THERMOPLASTIC.

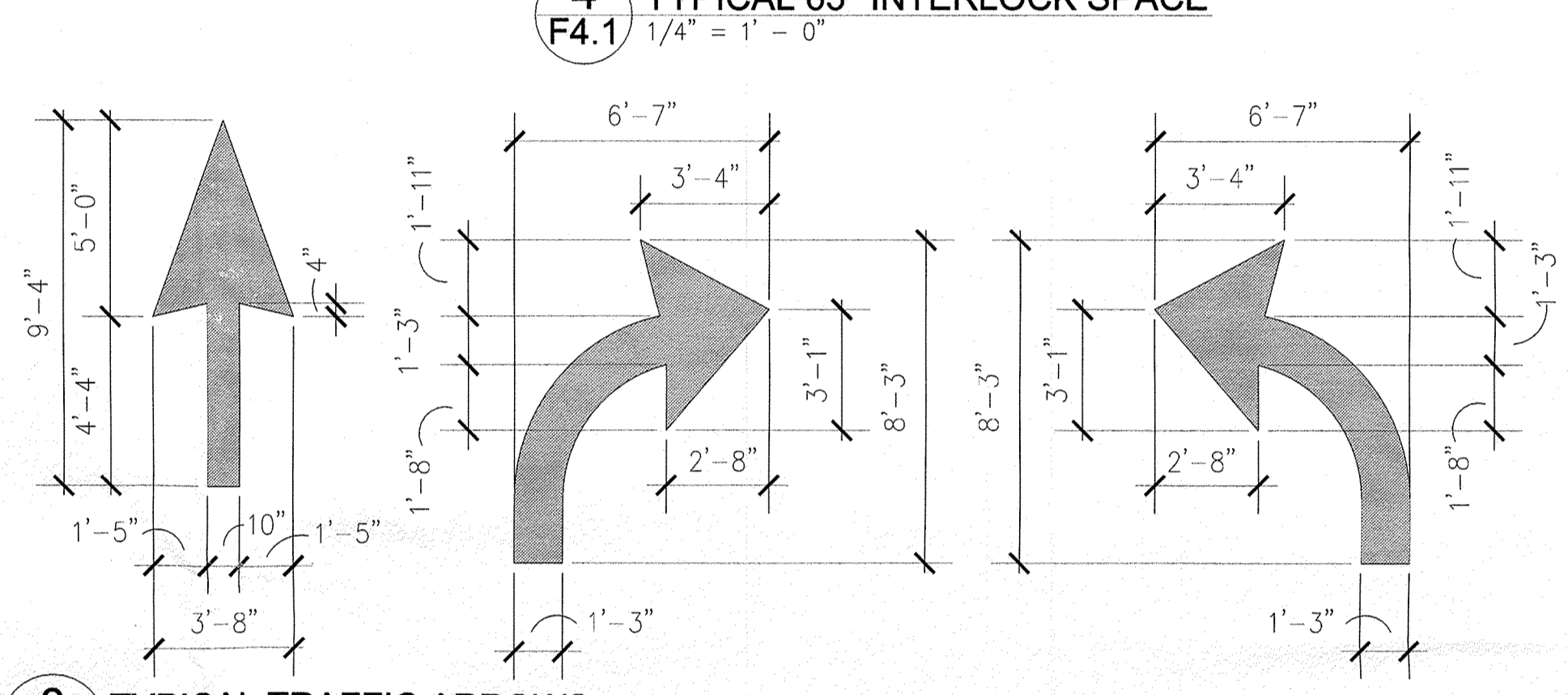

8 TYPICAL TRAFFIC ARROWS
F4.1 1/4" = 1' - 0"
USE WHITE EVER-BRITE (CALAPHOTE INC.) OR APPROVED EQUAL THERMOPLASTIC.
SEE PLANS FOR ARROW LOCATIONS (ALL ARROWS DETAILED ABOVE MAY, OR MAY NOT BE USED IN THIS PROJECT).

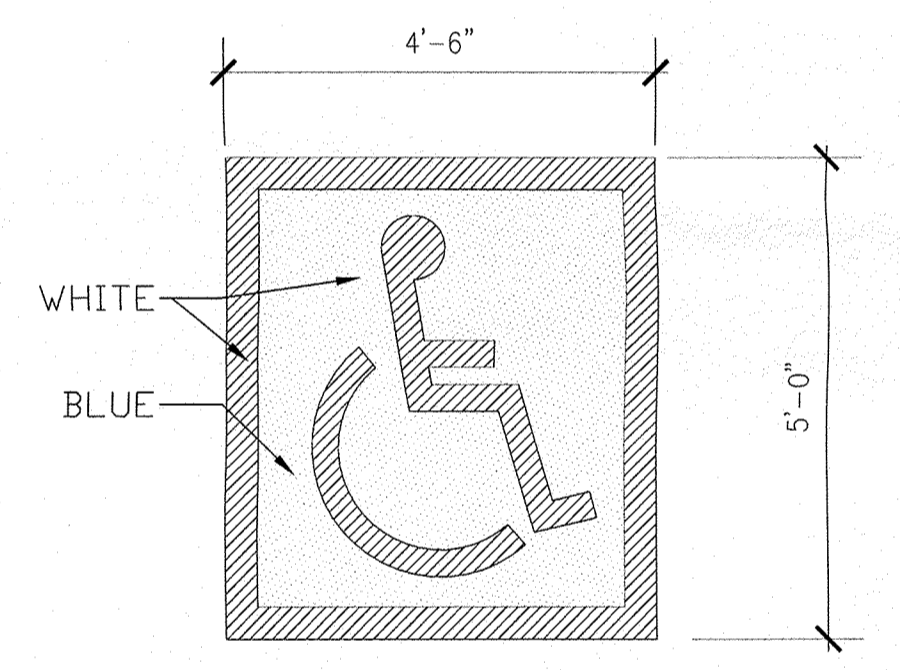

6 ACCESSIBLE SYMBOL
F4.1 1/2" = 1' - 0"
BLUE PAINTED BACKGROUND W/ WHITE PAINTED SYMBOL & BORDER - 4" STROKE WIDTH
SEE PLANS FOR LOCATIONS

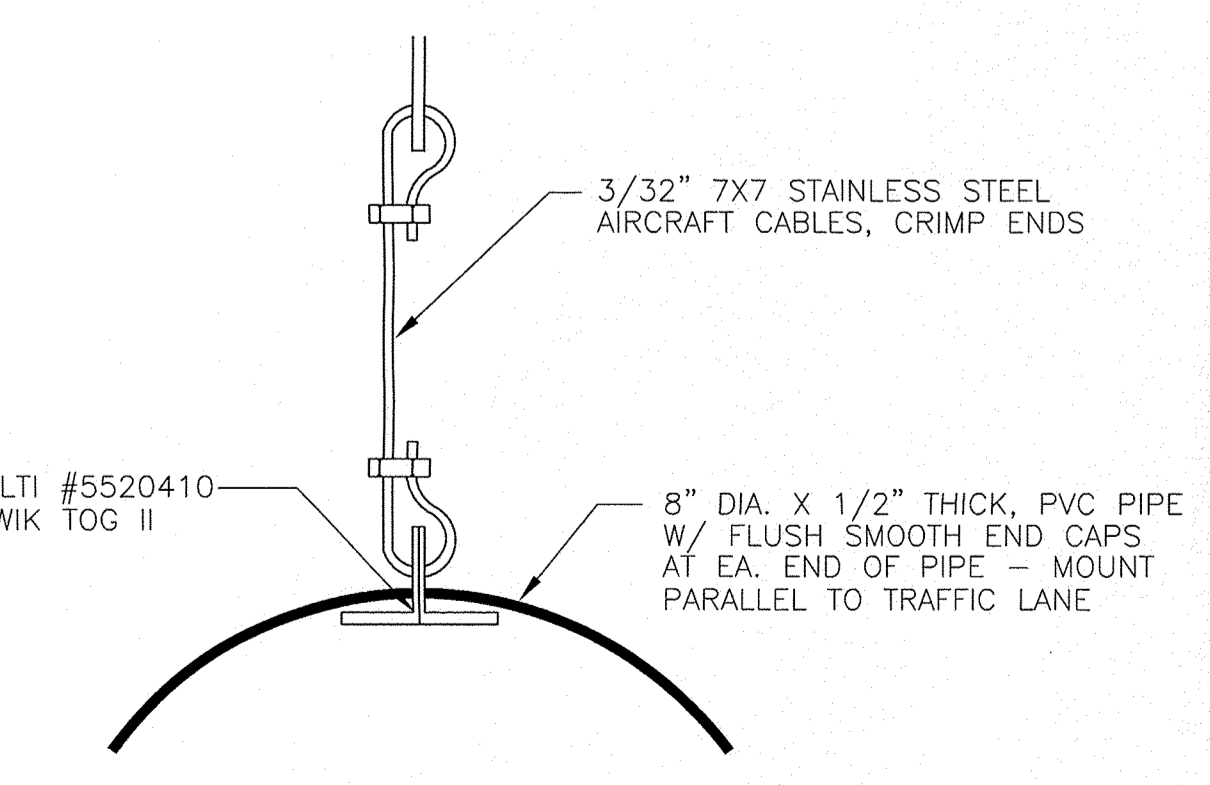
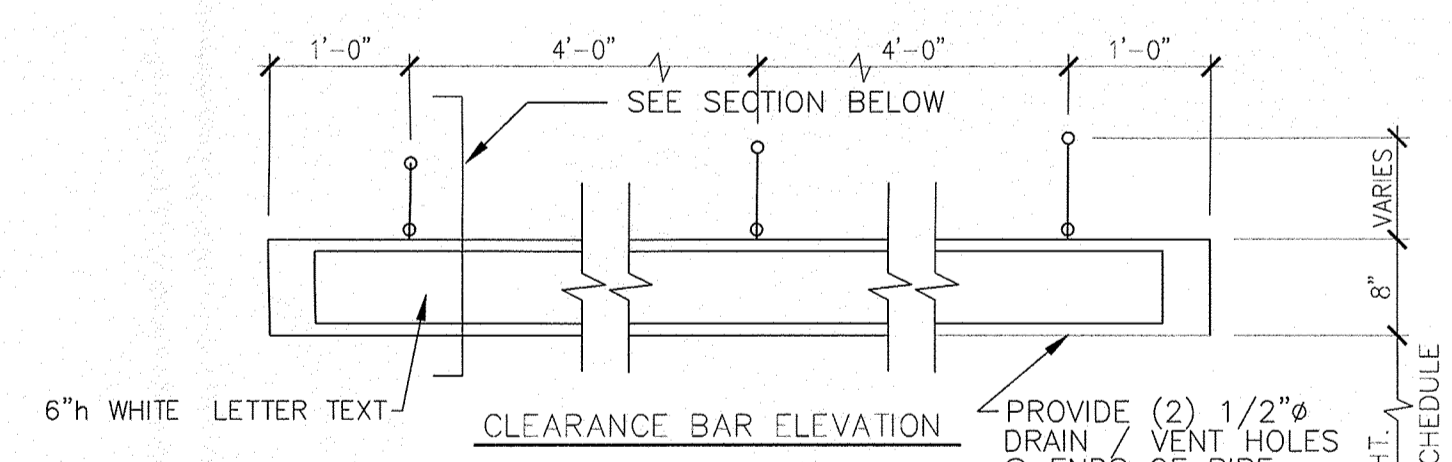

9 CLEARANCE BAR DETAILS
F4.1 3" = 1' - 0"
NOTE: CONTRACTOR TO VERIFY CLEARANCES PRIOR TO ORDERING TEXT

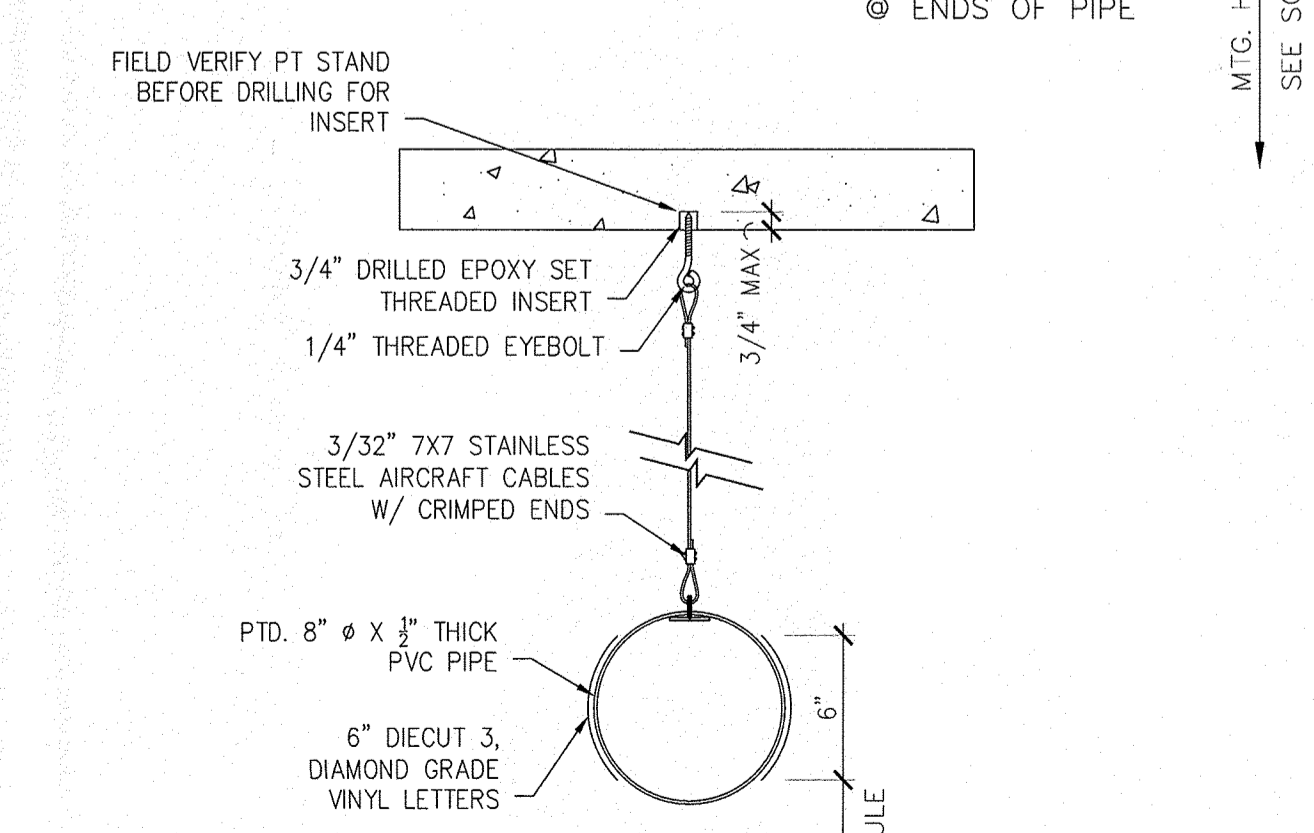

10 CLEARANCE BAR DETAILS
F4.1 1 1/2" = 1' - 0"

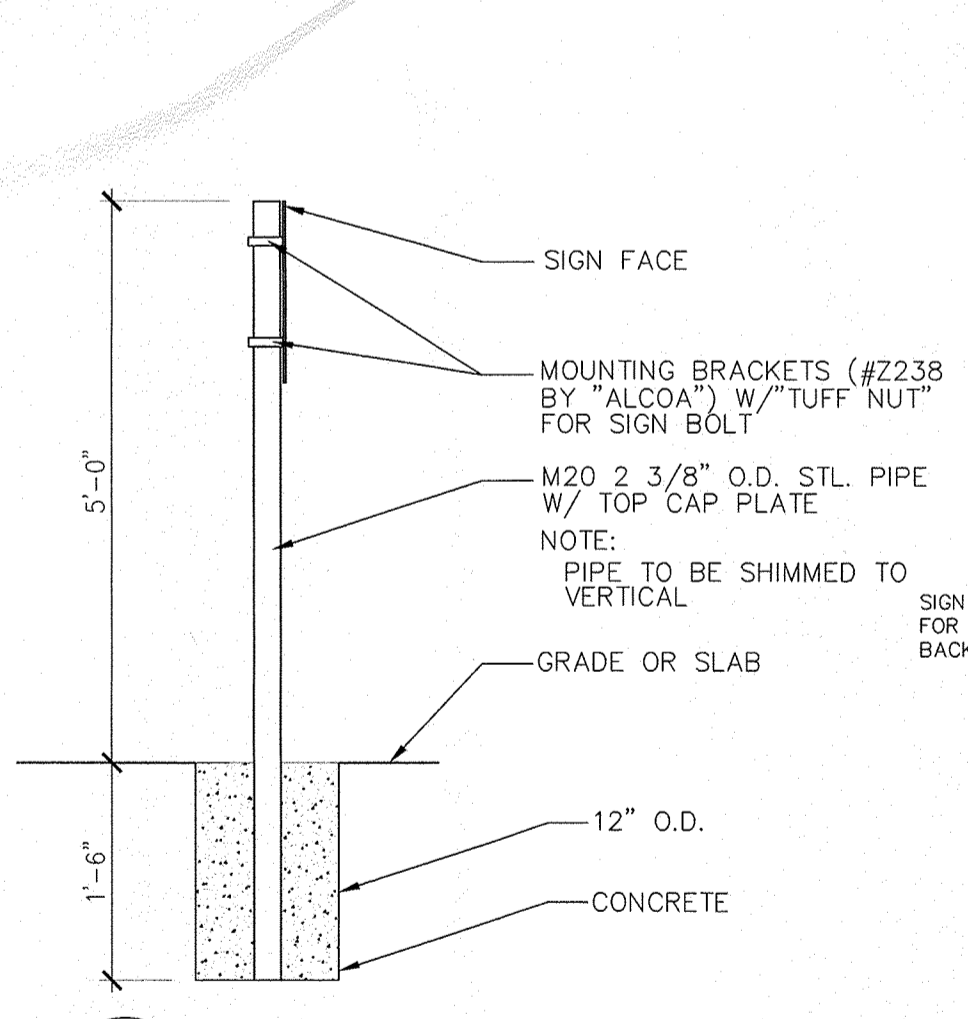

11 SIGN MOUNTING DETAIL
F4.1 3/4" = 1' - 0"

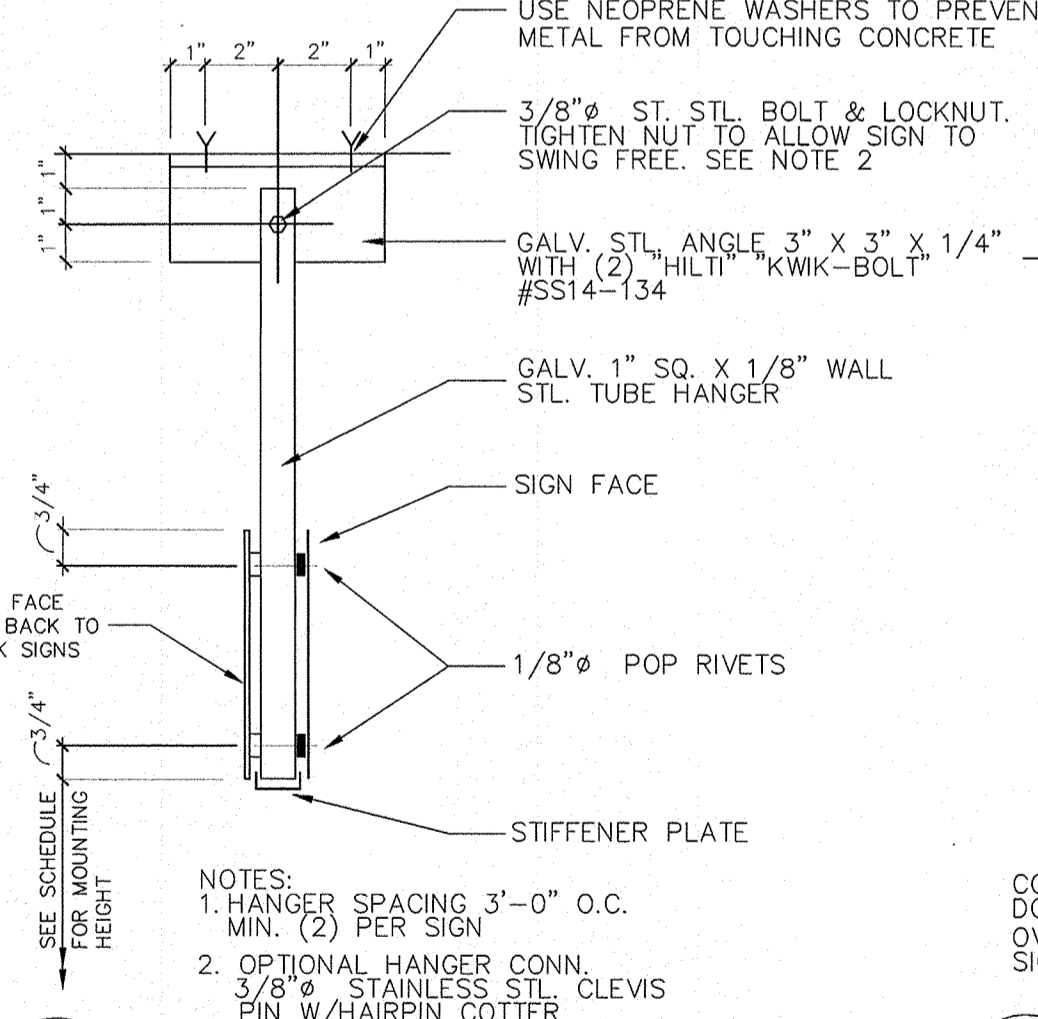

12 SIGN MOUNTING DETAIL
F4.1 3/4" = 1' - 0"

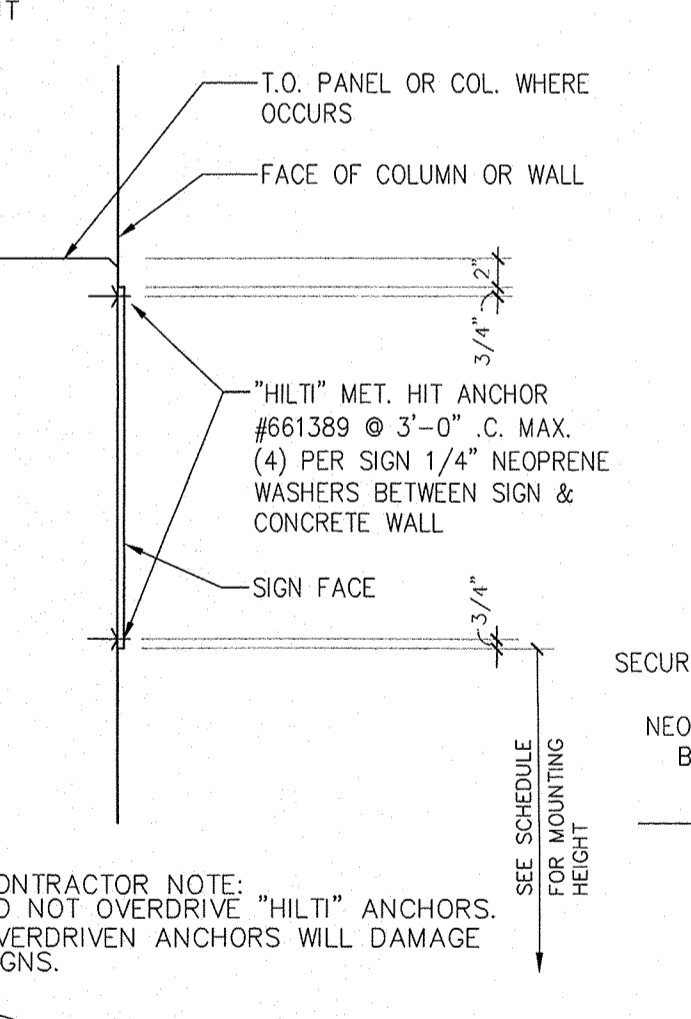

13 SIGN MOUNTING DETAIL
F4.1 3/4" = 1' - 0"

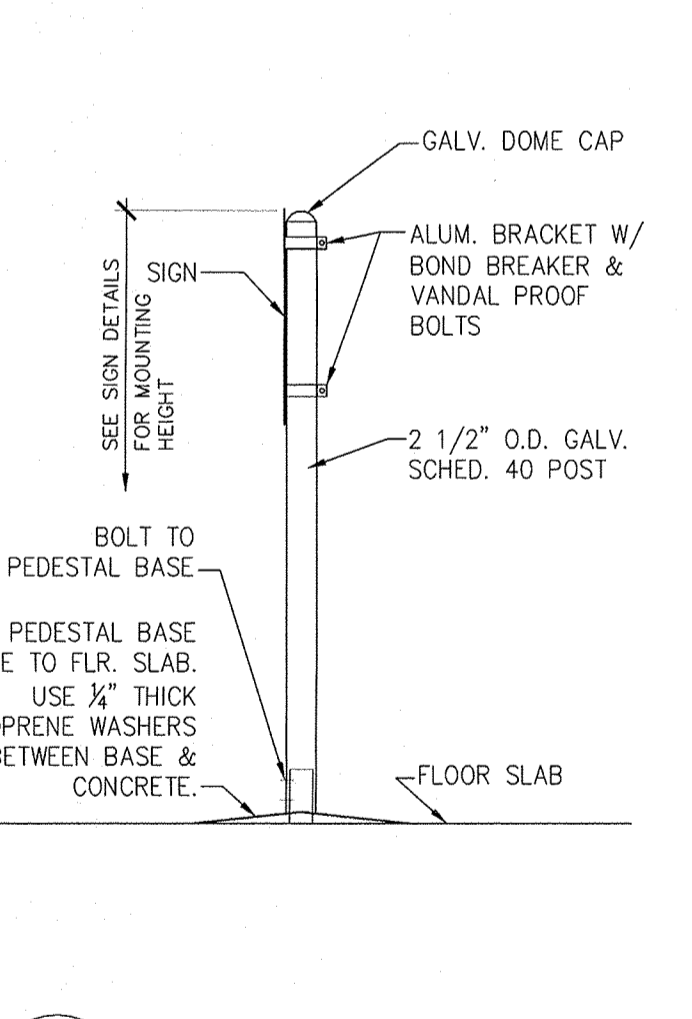

14 SIGN MOUNTING DETAIL
F4.1 3/4" = 1' - 0"

REV	DATE	BY	REVISION
1			
2			
3			
4			
5			
6			

MODULUS ARCHITECTS
220 COPPER AVE. N.W. SUITE 350
ALBUQUERQUE, NEW MEXICO 87102
PHONE (505) 338-1499 FAX (505) 338-1498

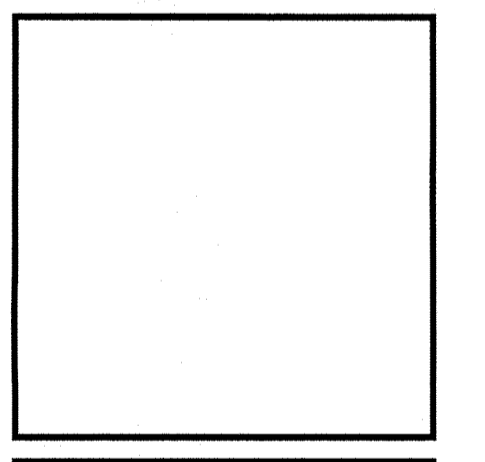

PROJECT TITLE	WINROCK SECTION 2
PROJECT NUMBER	WAROCK TOWN CENTER
JOB NO.	ALBUQUERQUE NEW MEXICO
DRAWN BY:	MJS
PDM	
SHEET TITLE	STRIPING & SIGNAGE DETAILS
DATE:	02/01/15
SCALE:	F4.1

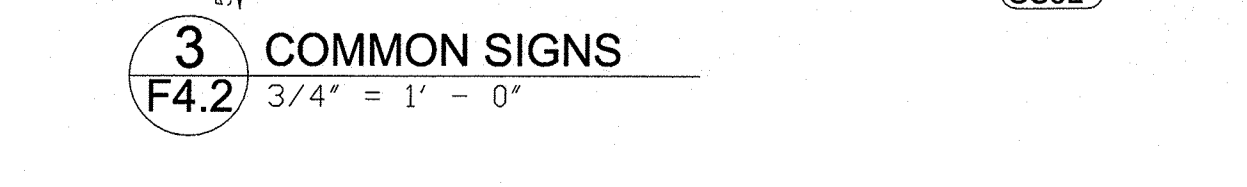
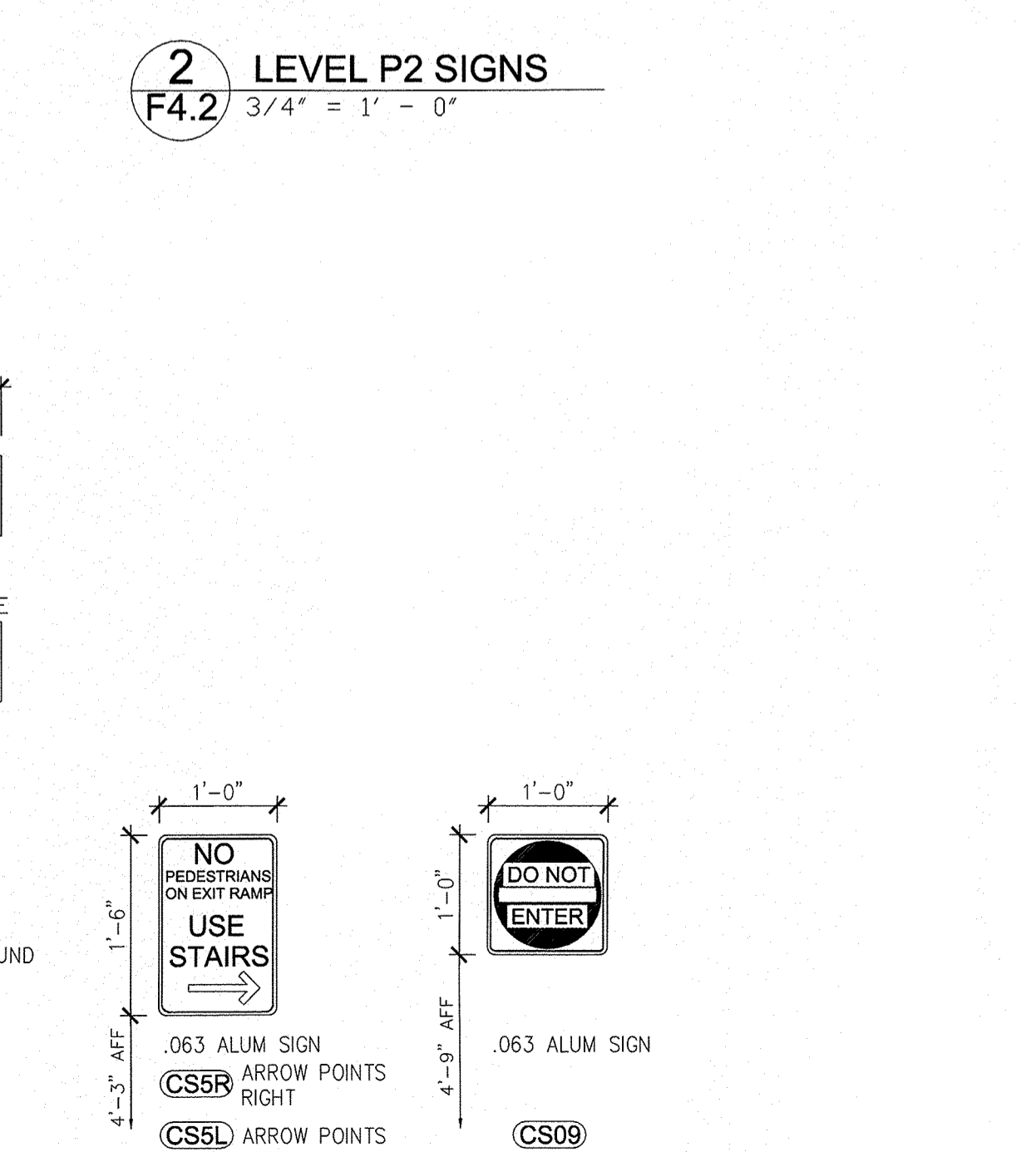
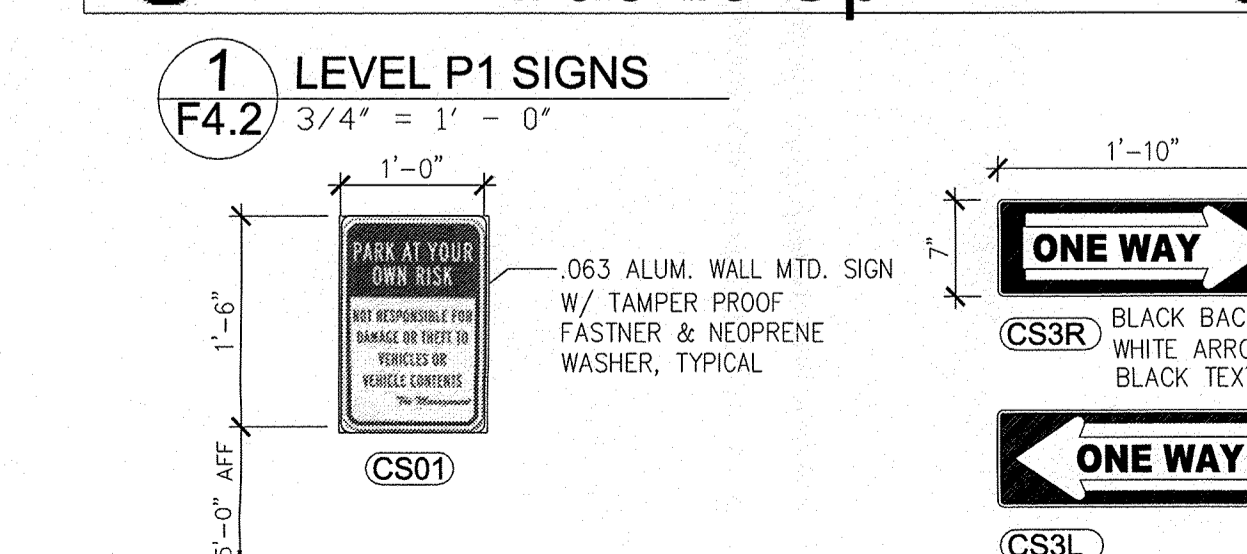
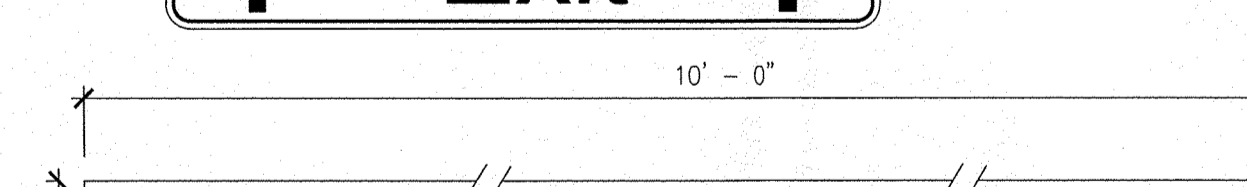
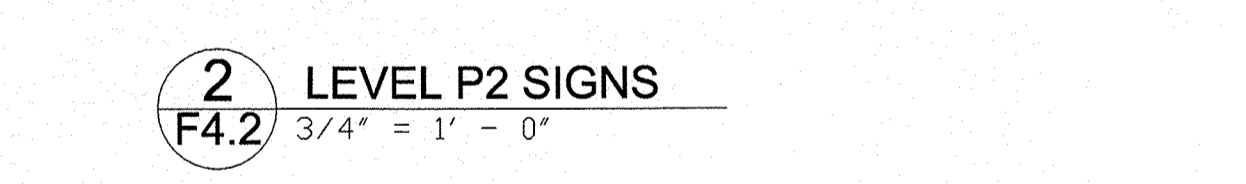
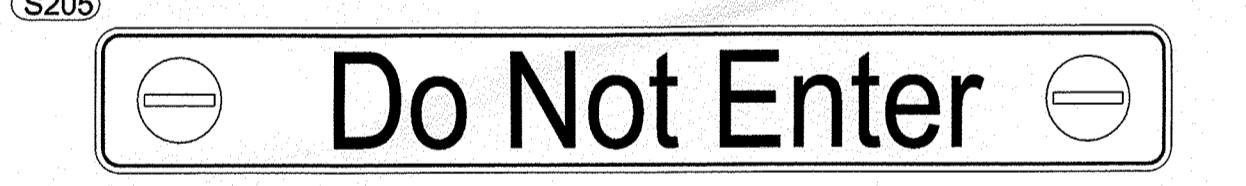
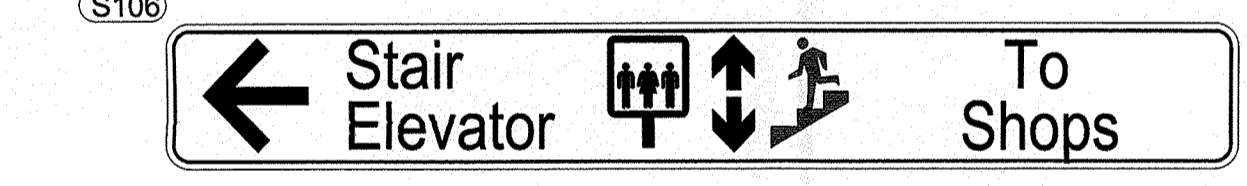
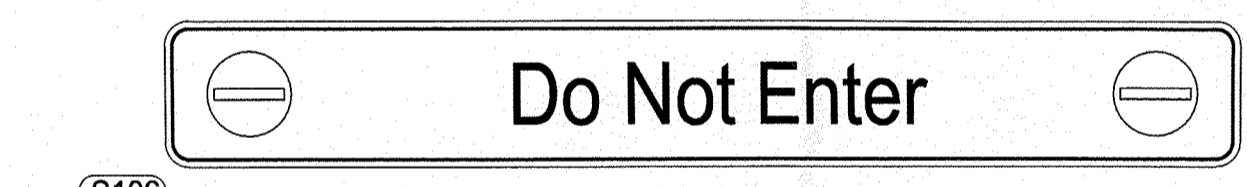
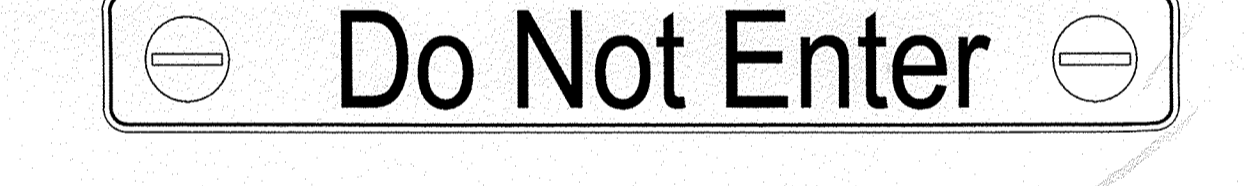
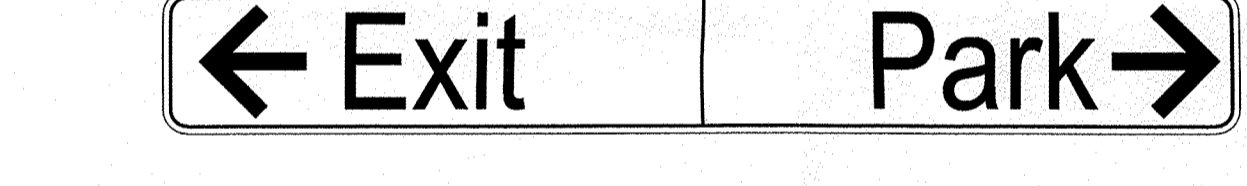
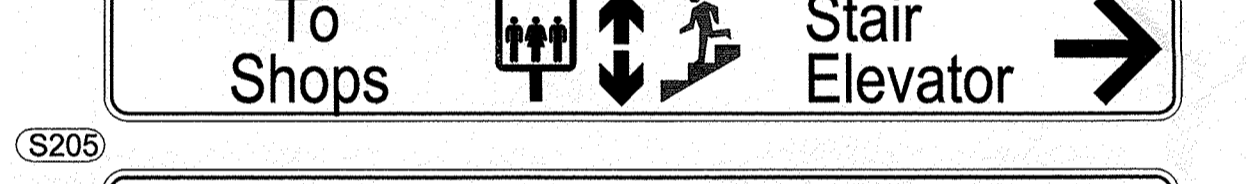
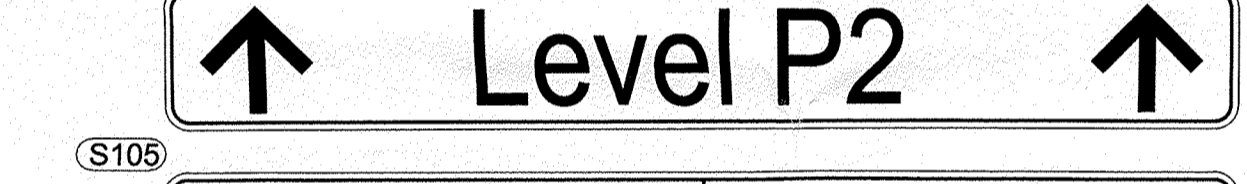
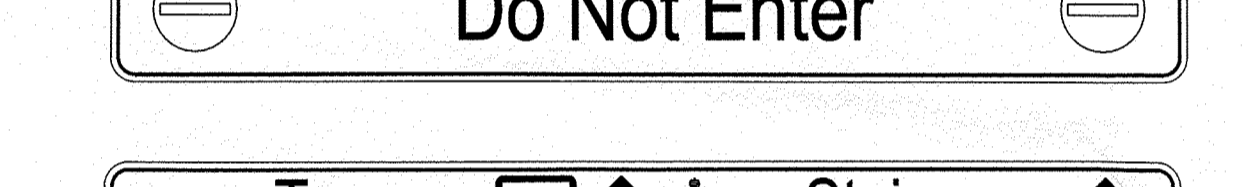
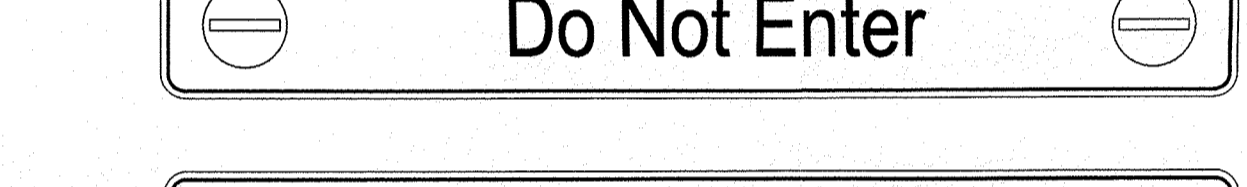
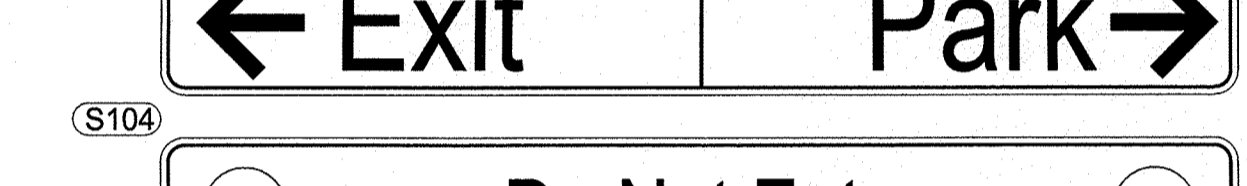
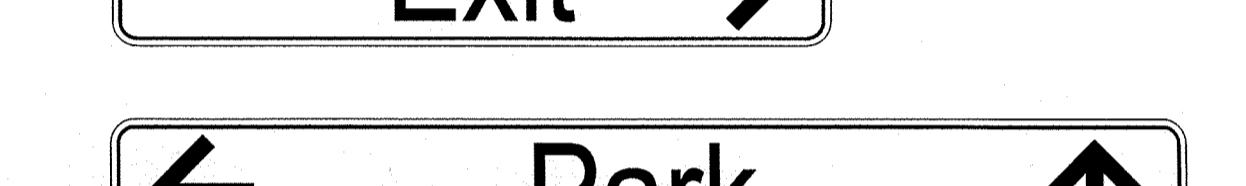
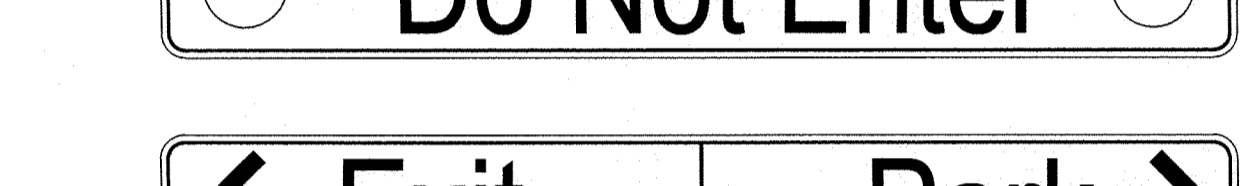
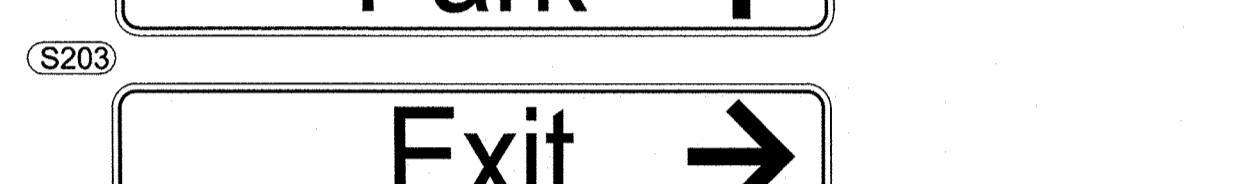
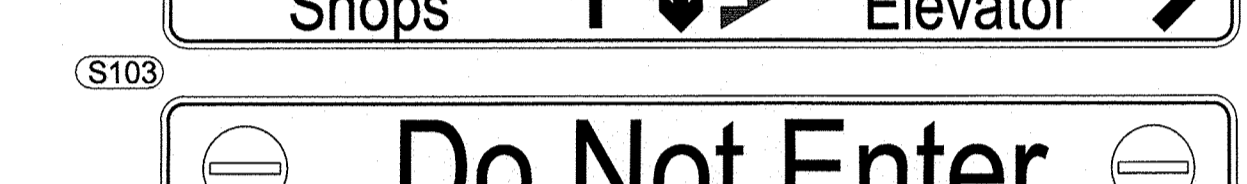
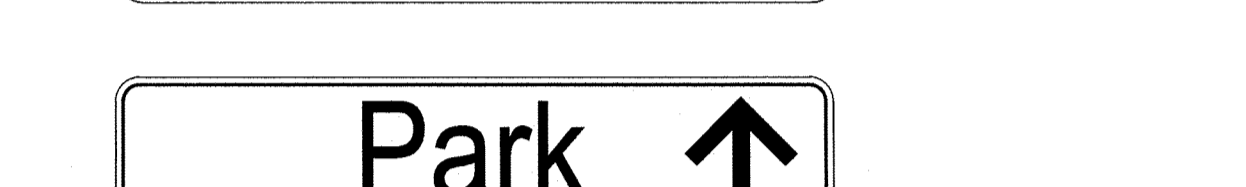
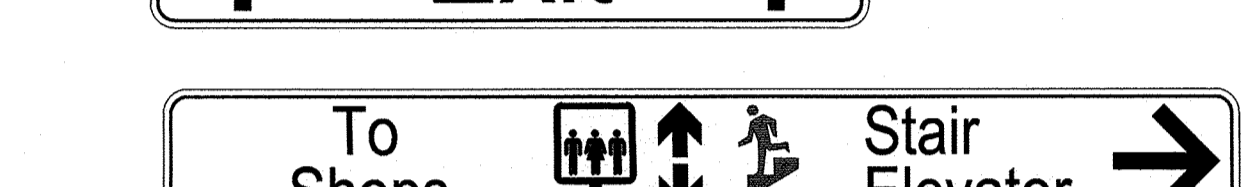
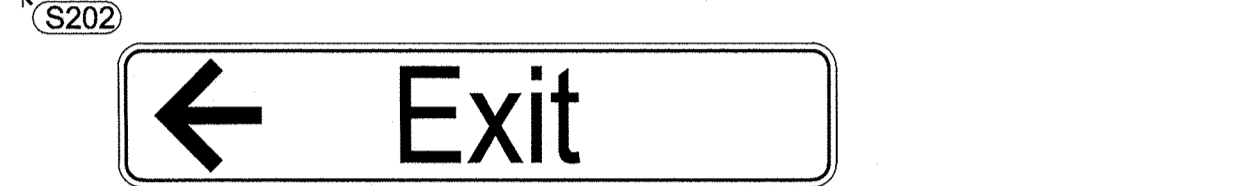
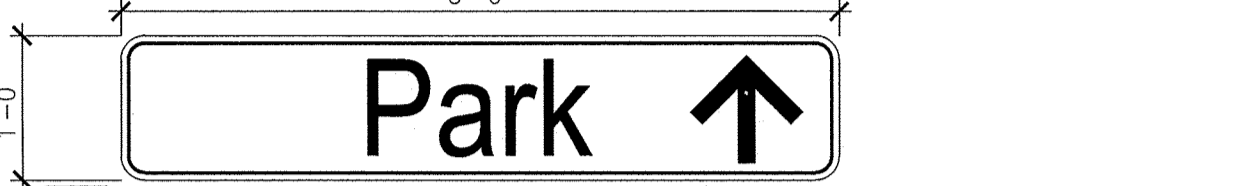
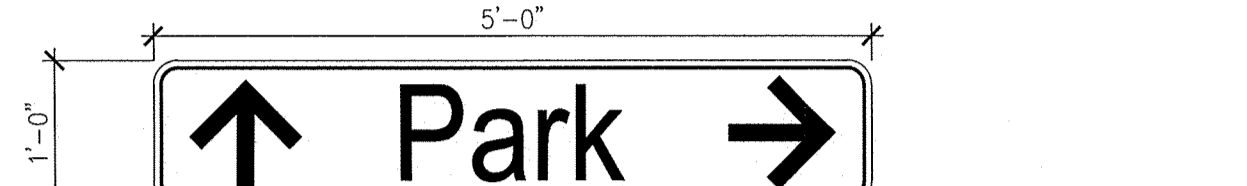
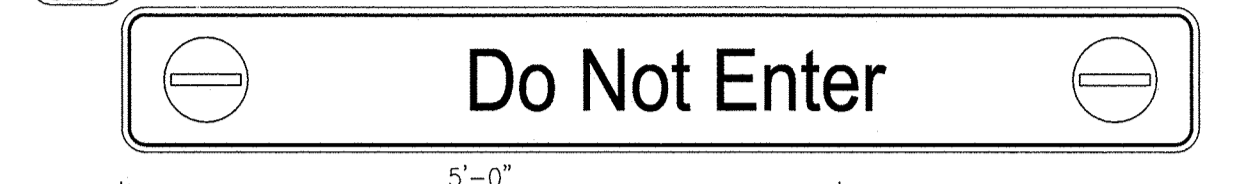
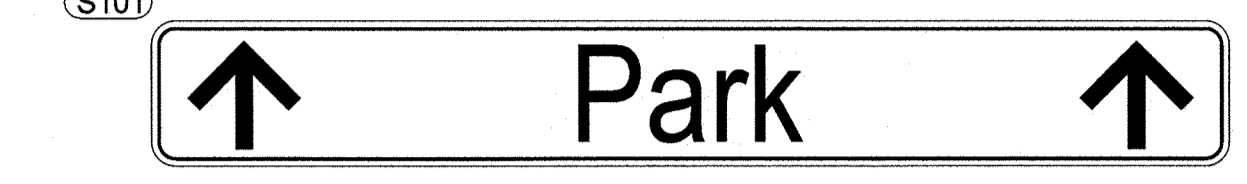
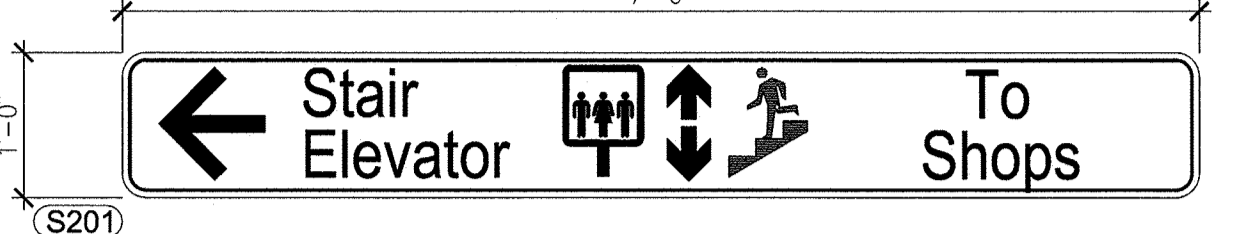
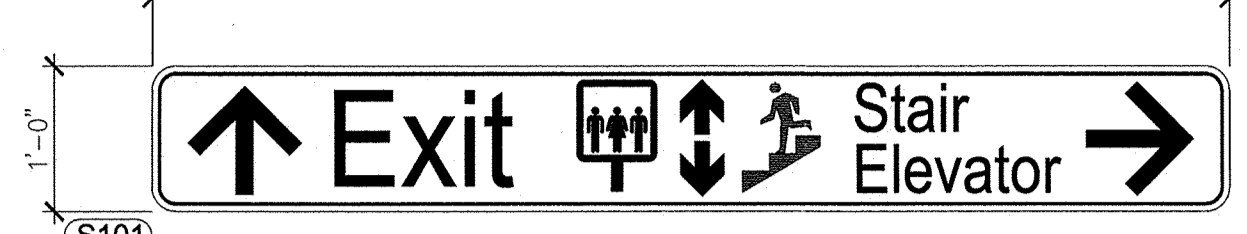
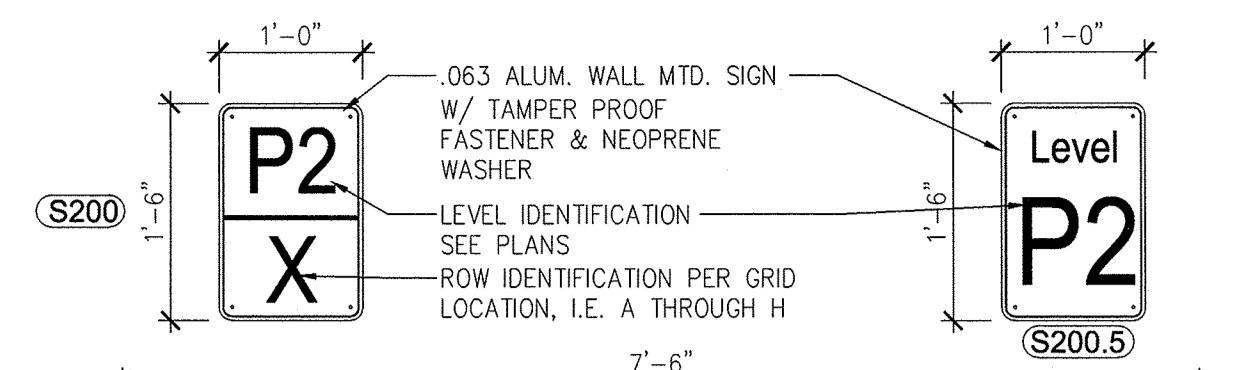
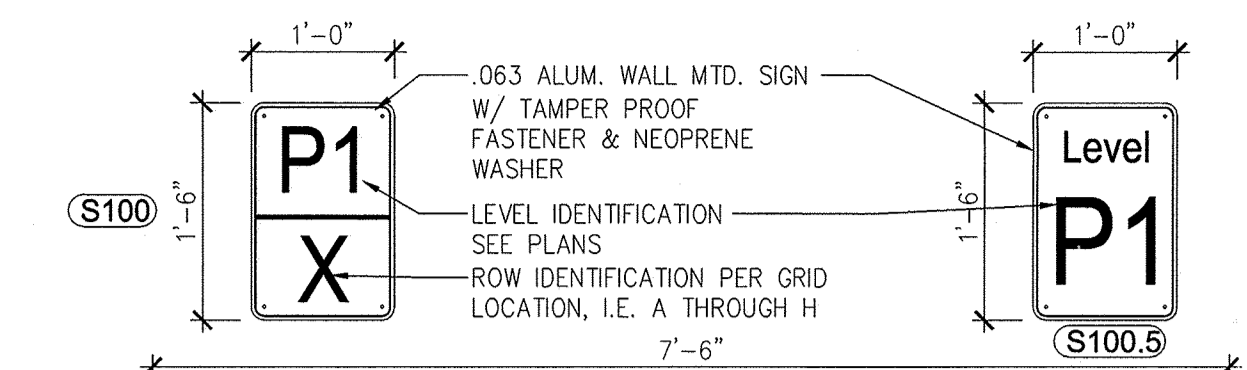

SIGN SCHEDULE

MARK	SIZE		SIGN DETAIL	BACKGROUND COLOR	COPY COLOR	MOUNTING		REMARKS
	W	L				DETAIL	HT.	
COMMON SIGNS								
CS01	1'-6"	1'-0"	3/F4.2	WHITE	BLACK	13/F4.1	5'-0"	
CS3R	7'	1'-10"	3/F4.2	BLACK	WHITE	13/F4.1	5'-0"	ARROW POINTING RIGHT
CS3L	7'	1'-10"	3/F4.2	BLACK	WHITE	13/F4.1	5'-0"	ARROW POINTING LEFT
CS5R	1'-6"	1'-0"	3/F4.2	WHITE	BLACK	13/F4.1	5'-0"	ARROW POINTING RIGHT
CS5L	1'-6"	1'-0"	3/F4.2	WHITE	BLACK	13/F4.1	5'-0"	ARROW POINTING LEFT
CS09	1'-0"	1'-0"	3/F4.2	WHITE	BLACK	13/F4.1	5'-0"	
LEVEL P1								
S100	1'-6"	1'-0"	1/F4.2	BLACK	WHITE	13/F4.1	5'-0"	
S101	12"	7'-6"	1/F4.2	DK BLUE	3290	12/F4.1	8'-3"	
S102	12"	5'-0"	1/F4.2	DK BLUE	3290	12/F4.1	8'-3"	
S103	12"	7'-6"	1/F4.2	DK BLUE	3290	12/F4.1	8'-3"	*DO NOT ENTER* SYMBOL: RED
S104	12"	7'-6"	1/F4.2	DK BLUE	3290	12/F4.1	8'-3"	*DO NOT ENTER* SYMBOL: RED
S105	12"	7'-6"	1/F4.2	DK BLUE	3290	12/F4.1	8'-3"	
S106	12"	7'-6"	1/F4.2	DK BLUE	3290	12/F4.1	8'-3"	*DO NOT ENTER* SYMBOL: RED
S106	12"	5'-0"	1/F4.2	DK BLUE	3290	12/F4.1	8'-3"	
S108	8'	10'-0"	1/F4.2	BLACK	3290	9&10/F4.1	8'-2"	8"Ø PVC PIPE SIGN
LEVEL P2								
S200	1'-6"	1'-0"	2/F4.2	WHITE	3290	13/F4.1	5'-0"	
S201	12"	7'-6"	2/F4.2	DK BLUE	3290	12/F4.1	8'-3"	*DO NOT ENTER* SYMBOL: RED
S202	12"	5'-0"	2/F4.2	DK BLUE	3290	12/F4.1	8'-3"	
S203	12"	5'-0"	2/F4.2	DK BLUE	3290	12/F4.1	8'-3"	
S204	12"	7'-6"	2/F4.2	DK BLUE	3290	12/F4.1	8'-3"	*DO NOT ENTER* SYMBOL: RED
S205	12"	7'-6"	2/F4.2	DK BLUE	3290	12/F4.1	8'-3"	*DO NOT ENTER* SYMBOL: RED

SIGNAGE GENERAL NOTES

- See F3.X series sheets for sign locations.
- Sign copy shall be Helvetica Medium, of size indicated on the schedule. Upper and lower case shall be used on all signs unless noted otherwise.
- Signs shall be mounted level and plumb.
- Sign backing materials shall be .080" Aluminum unless noted otherwise.
- Maximum bolt insert embedment length 1", unless noted otherwise.
- Backs and edges of all aluminum signs mounted directly to the structure shall be painted (sign background color) to prevent cathodic reaction.

SIGNAGE COLORS

Process Colors as manufactured by 3M Traffic Control Materials Division.

701	RED
705	BLACK
706	ORANGE
708	GREEN
709	GOLD
710	BLUE
712	TRAFFIC SIGN RED
713	RUSTIC BROWN
714	WARNING YELLOW
715	INTERSTATE BLUE
716	CONSTRUCTION ORANGE
717	BROWN
722	LEMON YELLOW
723	MAGENTA

3290	WHITE 'SCOTCHLITE' REFLECTIVE SHEETING - ENGINEER GRADE
580	WHITE 'SCOTCHLITE' REFLECTIVE SHEETING - ENGINEER GRADE

CHART 1
LEVEL COLORS FOR LOCATION IDENTIFICATION SIGNS:
LEVEL P1 - BLACK (705) BACKGROUND, WHITE (3290) COPY
LEVEL P2 - MAROON BACKGROUND, WHITE (3290) COPY
SUBMIT ALL COLORS TO ARCHITECT FOR APPROVAL.

SAMPLE SIGN

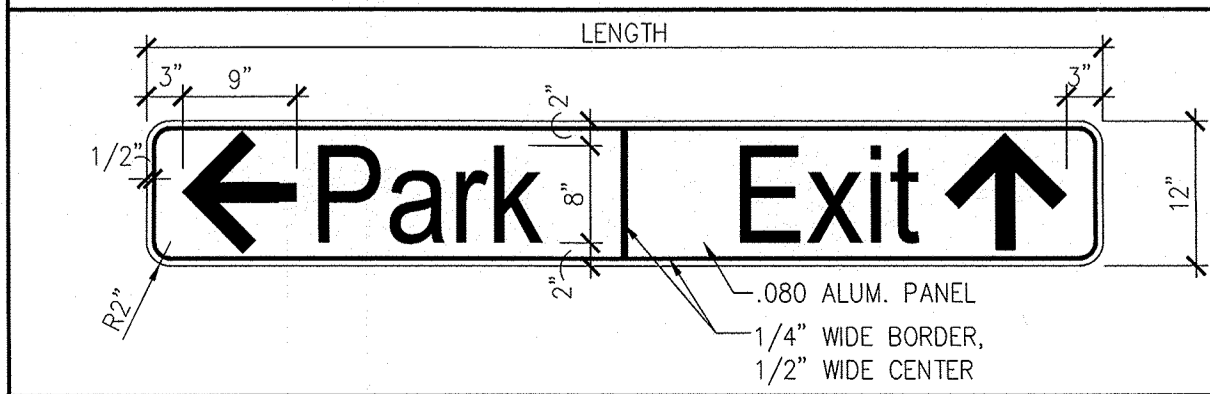

MODULUS ARCHITECTS
220 COPPER AVE. N.W. SUITE 350
ALBUQUERQUE, NEW MEXICO 87102
PHONE (505) 338-1499 FAX (505) 338-1498

PROJECT TITLE: WINROCK SECTION 2
WINROCK TOWN CENTER
ALBUQUERQUE, NEW MEXICO

DATE: 02/01/15
SCALE: F4.2

PROJECT NUMBER: JOB NO. X
DRAWN BY: MUS
SHEET TITLE: STRIPING & SIGNAGE DETAILS

REV	DATE	BY	REVISION
1			
2			
3			
4			
5			