

POINT OF PRESENCE FIBER HUT

SANDIA SCIENCE AND TECHNOLOGY PARK

ALBUQUERQUE, NEW MEXICO

APRIL 4, 2003

INDEX OF SHEETS

SHEET NO	SHEET TITLE	
1 OF 12	T1	COVER SHEET, INDEX OF SHEETS, LOCATION MAP
2 OF 12	L1	SITE PLAN LANDSCAPE
3 OF 12	C1	SITE DEVELOPMENT PLAN FOR BUILDING PERMIT - SITE LAYOUT/UTILITY PLAN
4 OF 12	C2	GRADING AND DRAINAGE PLAN
5 OF 12	S1	FOUNDATION, ROOF PLAN AND DETAILS
6 OF 12	S2	SHADE STRUCTURE PLAN AND DETAIL
7 OF 12	A1	FLOOR PLAN, ROOF PLAN, ELEVATIONS AND SECTIONS
8 OF 12	M1	HVAC FLOOR PLAN
9 OF 12	E1	ELECTRICAL SITE PLAN
10 OF 12	E2	POWER, LIGHTING AND SPECIAL SYSTEMS PLANS
11 OF 12	E3	LEGEND, PANEL SCHEDULE AND RISER DIAGRAM
12 OF 12	E4	LIGHTNING PROTECTION PLAN AND DUCT BANK DETAILS

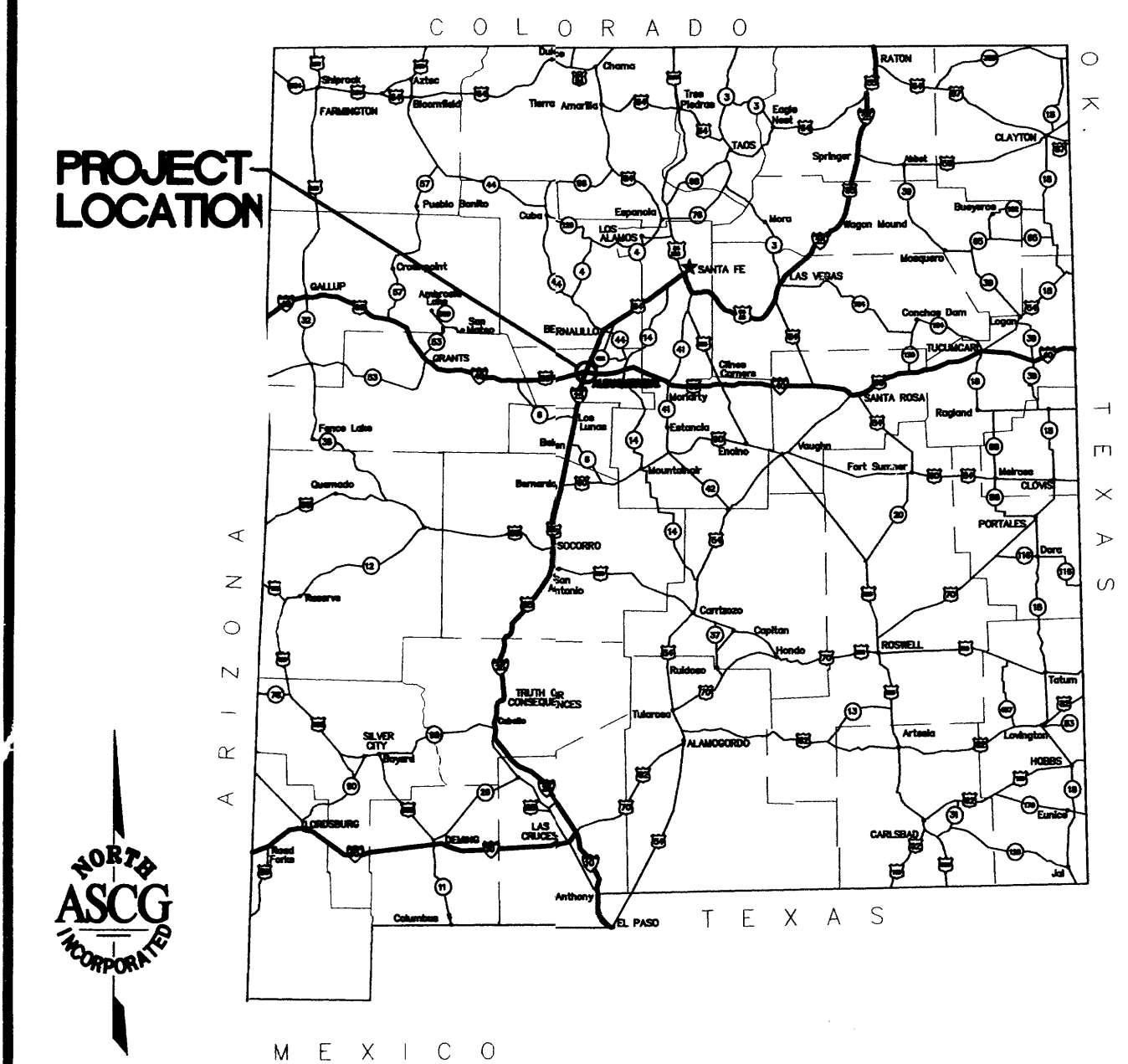

VICINITY MAP
NOT TO SCALE

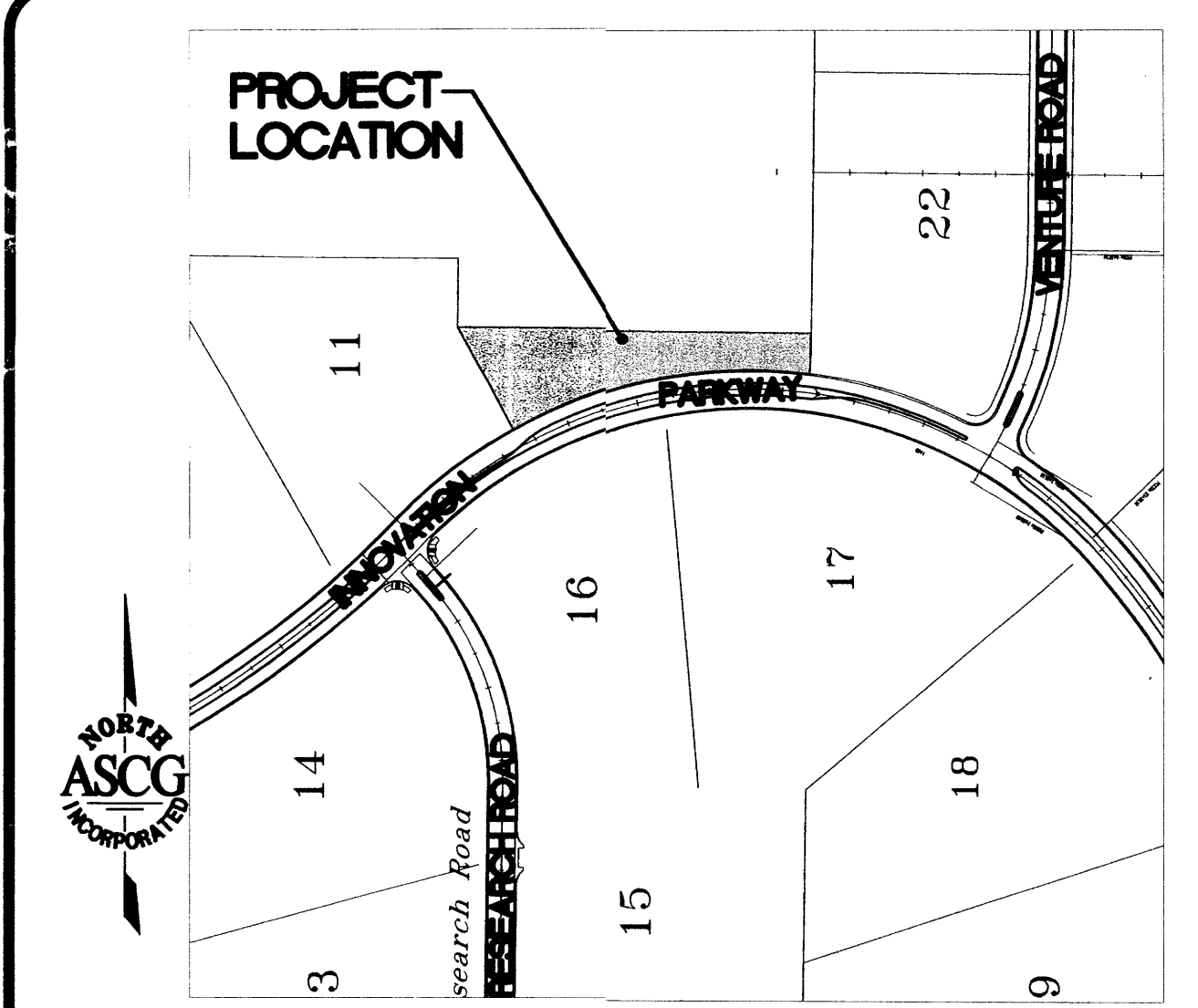

LOCATION MAP
NOT TO SCALE

ASCG
INCORPORATED
OF NEW MEXICO
ENGINEERS • ARCHITECTS • SURVEYORS • INSPECTION SERVICES

500 COPPER AVENUE NW, SUITE 500
ALBUQUERQUE, NEW MEXICO 87102-3150
PHONE 505.247.0294 • FAX 505.247.4845

J:\SSTP\4493.gen\01.dwg,03-27-03

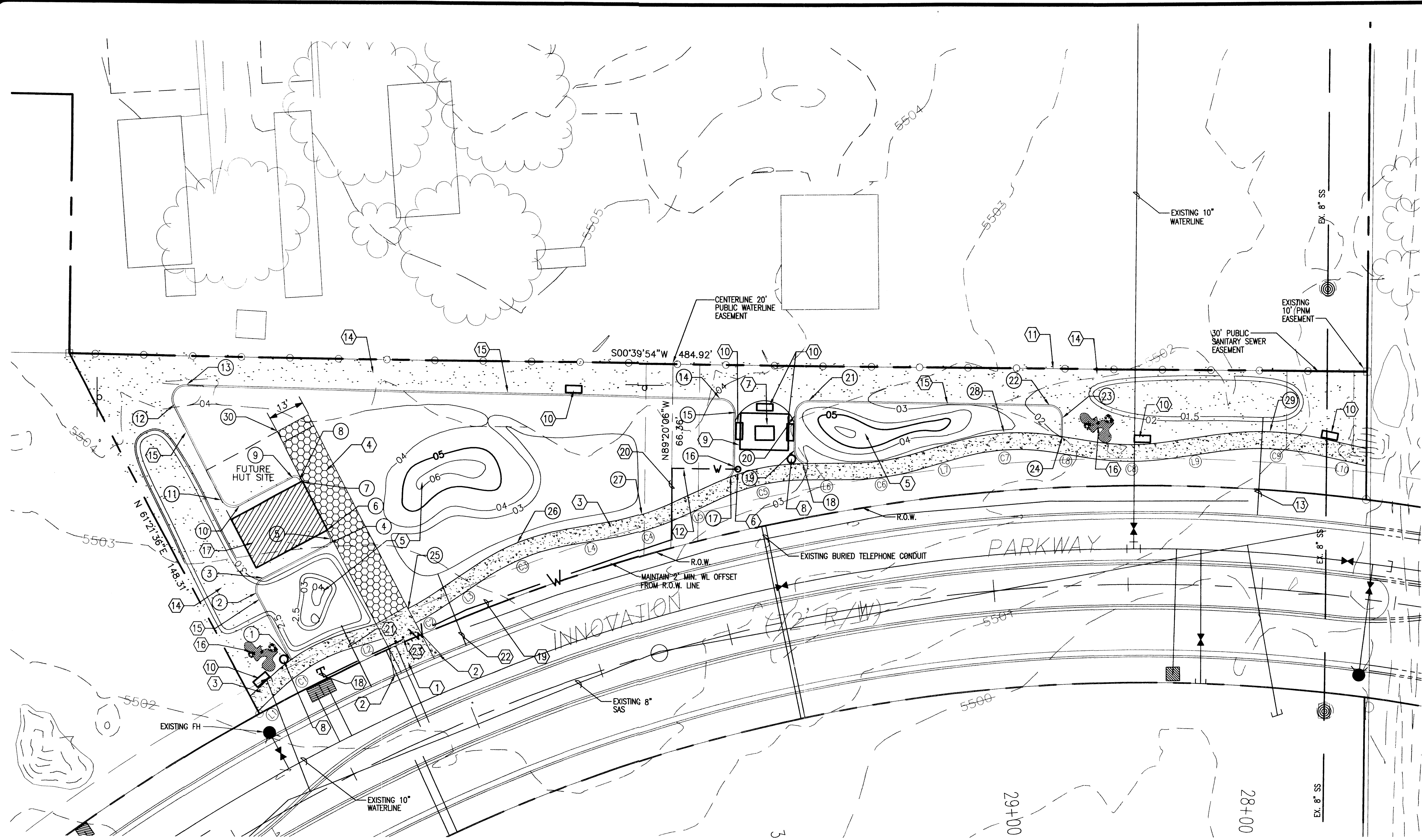

KEYED NOTES

- 1 CONSTRUCT DRIVEPAD PER COA STD DWG 2425.
- 2 MATCH TO STREET ELEVATIONS.
- 3 CONSTRUCT 6' WIDE PCC SIDEWALK SEE LANDSCAPE PLAN FOR DETAILS. MEANDER AS SHOWN.
- 4 CONSTRUCT TURF BLOCK. SEE LANDSCAPE PLAN FOR DETAILS.
- 5 CONSTRUCT BERM AS SHOWN.
- 6 INSTALL FROST FREE, CONCRETE BASE WATER FOUNTAIN, DRAINING TO A DRY WELL.
- 7 INSTALL ADA ACCESSIBLE PICNIC TABLE.
- 8 INSTALL TRASH CAN.
- 9 CONSTRUCT SHADE STRUCTURE.
- 10 INSTALL BENCH.
- 11 WROUGHT IRON FENCE BY OTHERS.
- 12 INSTALL 25 LF 1" DIA. SCH40 PVC PIPE, CONNECT TO NEW WATER FOUNTAIN.
- 13 INSTALL 35 LF 2" DIA. SCH40 PVC DRAIN PIPE, INV(W) @5499.65, INV (E)=5501.33. PLACE DRAIN PIPE THROUGH EXISTING CURB AS PER C.O.A. STD. DWG. 2235. SEE DRAIN PIPE INLET DETAIL THIS SHEET.
- 14 INSTALL GRAVEL. SEE LANDSCAPE PLANS FOR DETAILS.
- 15 CONSTRUCT STEEL EDGING. SEE LANDSCAPE PLANS FOR DETAILS.
- 16 INSTALL BOLLARDERS. SEE LANDSCAPE PLANS FOR DETAILS.
- 17 CONSTRUCT FIBER HUT. SEE ARCHITECTURAL PLANS FOR DETAILS.
- 18 TIE TO EXISTING 1" COPPER METERED WATER SERVICE LINE DOWNSTREAM OF METER BOX (CONTACT CITY NEW SERVICES FOR METER INSTALLATION). INSTALL 1" COPPER TEE WITH DISSIMILAR MATERIALS ADAPTER. PROVIDE 1" COPPER STUBOUT WITH CAP.
- 19 INSTALL 140 LF 1" DIA. SCH40 PVC PIPE. WL SHALL BE OFFSET 2' BEHIND PROPERTY LINE. INSTALL BACKFLOW PREVENTION DEVICE. INSTALL 1-1" DIA. SCH40 PVC 90° BEND DEFLECT JOINTS AS REQUIRED.
- 20 INSTALL 26 LF 1" DIA. SCH40 PVC PIPE. INSTALL 1-1" DIA. SCH40 PVC 90° BEND.
- 21 INSTALL 25 LF 2" DIA. SCH40 PVC DRAIN PIPE, INV(W) @5501.73, INV (E) = 5502.33. PLACE DRAIN PIPE THROUGH EXISTING CURB AS PER C.O.A. STD. DWG 2235. SEE DRAIN PIPE INLET DETAIL THIS SHEET.
- 22 INSTALL 25 LF 2" DIA. SCH40 PVC DRAIN PIPE, INV(W) @5501.49, INV (E) = 5502.83. PLACE DRAIN PIPE THROUGH EXISTING CURB AS PER C.O.A. STD. DWG 2235. SEE DRAIN PIPE INLET DETAIL THIS SHEET.
- 23 INSTALL 3-REMOVABLE BOLLARDS AS PER C.O.A. STD. DWG. 2250 @ 3.25' O.C., COORDINATE LOCATION OF CENTRAL BOLLARD @ N: 1476019.01, E: 1558642.50

GENERAL NOTES

- 1 SURVEY BASE INFORMATION TAKEN FROM ALTA/ACSM LAND TITLE SURVEY, TRACT G, SANDIA SCIENCE & TECHNOLOGY PARK, BY BOHANNAN HUSTON, DATED NOVEMBER, 2001.
- 2 WL SHALL HAVE 2' MIN. COVER, AND SHALL BE LOCATED 2' EAST OF ROW LINE.

CONSTRUCTION POINTS

1 N 1476061.08 E 1558634.11	16 N 1475895.21 E 1558705.36
2 N 1476073.90 E 1558658.29	17 N 1475896.80 E 1558701.54
3 N 1476071.37 E 1558664.27	18 N 1475869.75 E 1558706.58
4 N 1476047.01 E 1558676.92	19 N 1475872.99 E 1558711.38
5 N 1476046.37 E 1558678.94	20 N 1475872.83 E 1558723.77
6 N 1476047.86 E 1558681.75	21 N 1475867.22 E 1558729.17
7 N 1476057.48 E 1558699.30	22 N 1475777.44 E 1558772.43
8 N 1476057.82 E 1558699.96	23 N 1475772.54 E 1558722.33
9 N 1476060.52 E 1558700.81	24 N 1475772.65 E 1558716.13
10 N 1476080.31 E 1558690.53	25 N 1476017.23 E 1558653.27
11 N 1476087.03 E 1558692.63	26 N 1475976.30 E 1558677.24
12 N 1476104.90 E 1558726.31	27 N 1475929.81 E 1558687.86
13 N 1476100.39 E 1558733.66	28 N 1475794.28 E 1558717.32
14 N 1475900.08 E 1558729.79	29 N 1475695.30 E 1558717.53
15 N 1475894.93 E 1558724.20	

CURVE TABLE

CURVE	RADIUS	LENGTH	DELTA	TANGENT	CHORD BEARING	CHORD
C1	63.00	29.68	26°59'30"	15.12	N30°11'13"W	29.41
C2	132.51	13.46	05°49'12"	6.74	S30°19'59"E	13.45
C3	78.00	32.09	23°34'16"	16.27	N21°29'56"W	31.86
C4	122.50	20.95	09°47'54"	10.50	S17°05'51"E	20.92
C5	76.00	31.46	23°43'06"	15.96	N12°14'04"W	31.24
C6	97.50	25.77	15°08'32"	12.96	S07°56'47"E	25.69
C7	82.00	34.70	24°14'35"	17.61	N03°23'46"W	34.44
C8	101.50	29.37	16°34'42"	14.79	S00°26'11"W	29.27
C9	110.00	38.77	20°11'40"	19.59	N02°14'40"E	38.57

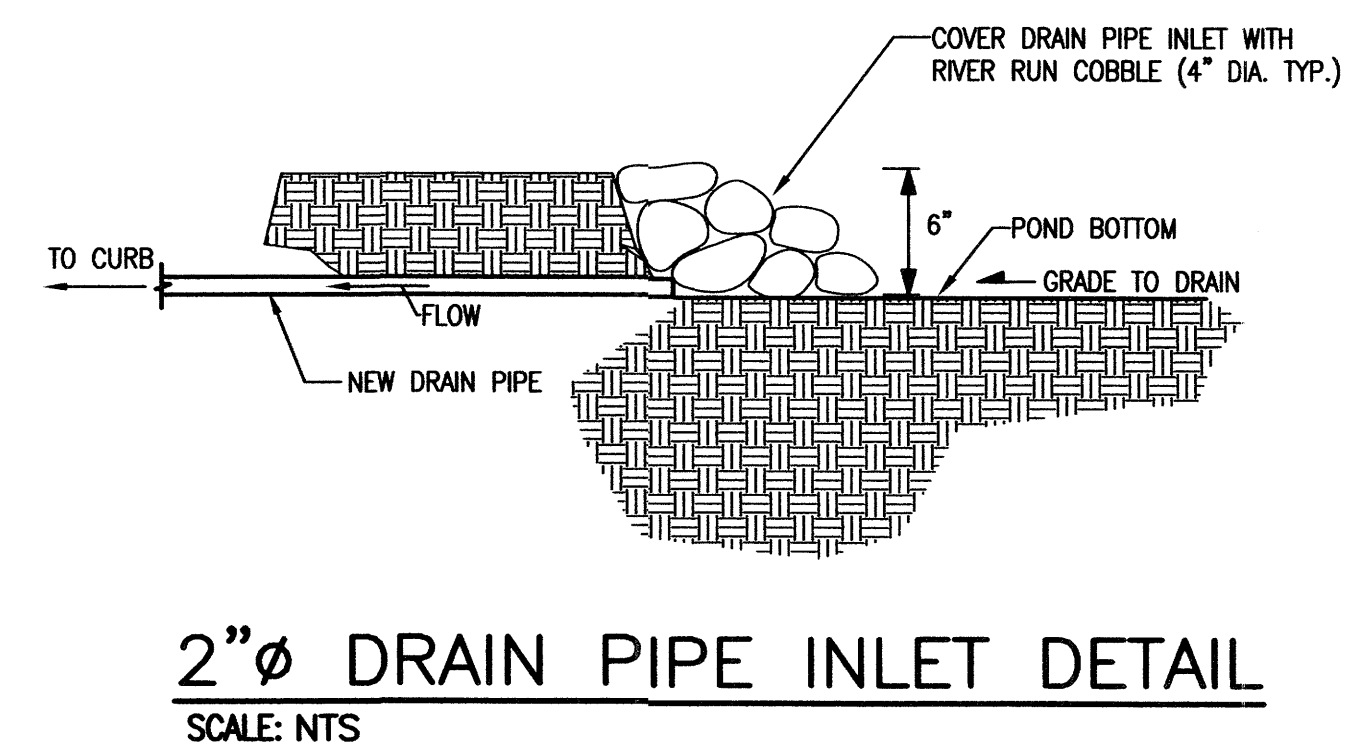

LINE TABLE

LINE	LENGTH	BEARING	START NORTHING	START EASTING	END NORTHING	END EASTING
L1	12.01	S43°40'58"E	1476073.11	1558615.24	1476064.43	1558623.54
L2	13.23	S16°41'28"E	1476039.01	1558638.32	1476026.34	1558642.12
L3	17.39	S33°17'04"E	1476002.85	1558654.74	1475988.32	1558664.29
L4	20.78	S09°42'48"E	1475958.67	1558675.96	1475938.19	1558679.47
L5	20.25	S24°05'37"E	1475918.19	1558685.62	1475899.70	1558693.89
L6	17.18	S00°22'31"E	1475869.18	1558700.51	1475851.99	1558700.62
L7	16.13	S15°31'03"E	1475826.55	1558704.17	1475811.00	1558708.49
L8	14.56	S08°43'32"W	1475776.63	1558710.53	1475762.23	1558708.32
L9	18.26	S07°51'10"E	1475732.97	1558708.09	1475714.88	1558710.59
L10	17.48	S12°20'30"W	1475676.34	1558709.08	1475659.26	1558705.34

NOTICE TO CONTRACTORS

1. AN EXCAVATION/CONSTRUCTION PERMIT WILL BE REQUIRED BEFORE BEGINNING ANY WORK WITHIN CITY RIGHT-OF-WAY.
2. ALL WORK DETAILED ON THESE PLANS TO BE PERFORMED, EXCEPT AS OTHERWISE STATED OR PROVIDED HEREON, SHALL BE CONSTRUCTED IN ACCORDANCE WITH CITY OF ALBUQUERQUE INTERIM STANDARD SPECIFICATIONS FOR PUBLIC WORKS CONSTRUCTION, 1985.
3. TWO WORKING DAYS PRIOR TO ANY EXCAVATION, CONTRACTOR MUST CONTACT LINE LOCATING SERVICE, 765-1234, FOR LOCATION OF EXISTING UTILITIES.
4. PRIOR TO CONSTRUCTION, THE CONTRACTOR SHALL EXCAVATE AND VERIFY THE HORIZONTAL AND VERTICAL LOCATIONS OF ALL CONSTRUCTIONS. SHOULD A CONFLICT EXIST, THE CONTRACTOR SHALL NOTIFY THE ENGINEER SO THAT THE CONFLICT CAN BE RESOLVED WITH A MINIMUM AMOUNT OF DELAY.
5. BACKFILL COMPACTION SHALL BE ACCORDING TO TRAFFIC/STREET USE.
6. MAINTENANCE OF THESE FACILITIES SHALL BE THE RESPONSIBILITY OF THE OWNER OF THE PROPERTY SERVED.
7. WORK ON ARTERIAL STREETS SHALL BE PERFORMED ON A 24-HOUR BASIS.

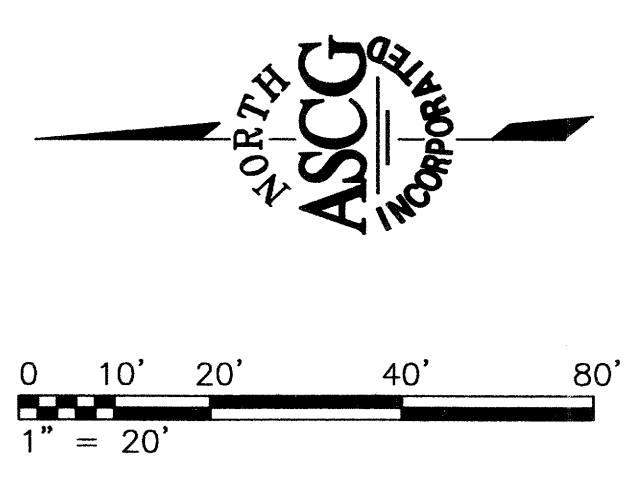

THIS SITE DEVELOPMENT PLAN FOR BUILDING PERMIT IS CONSISTENT WITH THE JUNE 2001 SANDIA SCIENCE AND TECHNOLOGY PART MASTER DEVELOPMENT PLAN

DEVELOPMENT REVIEW BOARD CHAIR
FOR PLANNING DIRECTOR

DATE

APPROVAL	NAME	DATE
INSPECTOR		

ASCG
INCORPORATED
ENGINEERS, ARCHITECTS, SURVEYORS, INSPECTION SERVICES
1651 AMERICA'S PARKWAY, SUITE 145
ALBUQUERQUE, NEW MEXICO 87110-8772
PHONE 505.247.0294 • FAX 505.242.4645

ENTERPRISE ELECTRICAL SERVICES INC.
9708 BELL AVE. SE
ALBUQUERQUE, NEW MEXICO 87113

SUMMIT CONSTRUCTION
900 HAZELDINE AVE. SE
ALBUQUERQUE, NEW MEXICO 87106

SANDIA SCIENCE AND TECHNOLOGY PARK

TELECOMMUNICATIONS DISTRIBUTION SYSTEM
SANDIA SCIENCE AND TECHNOLOGY PARK
SITE DEVELOPMENT PLAN FOR BUILDING PERMIT
SITE LAYOUT/UTILITY PLAN

REVISIONS

NUMBER	DATE

J:\SSIP\Gnd\DWG\SITE_PLAN.dwg\JOB 03-25-03

JOB NO:
DATE:
DRAWN BY: CAB
CHECKED BY: PR
DRAWING NO:
C-1
SHEET OF

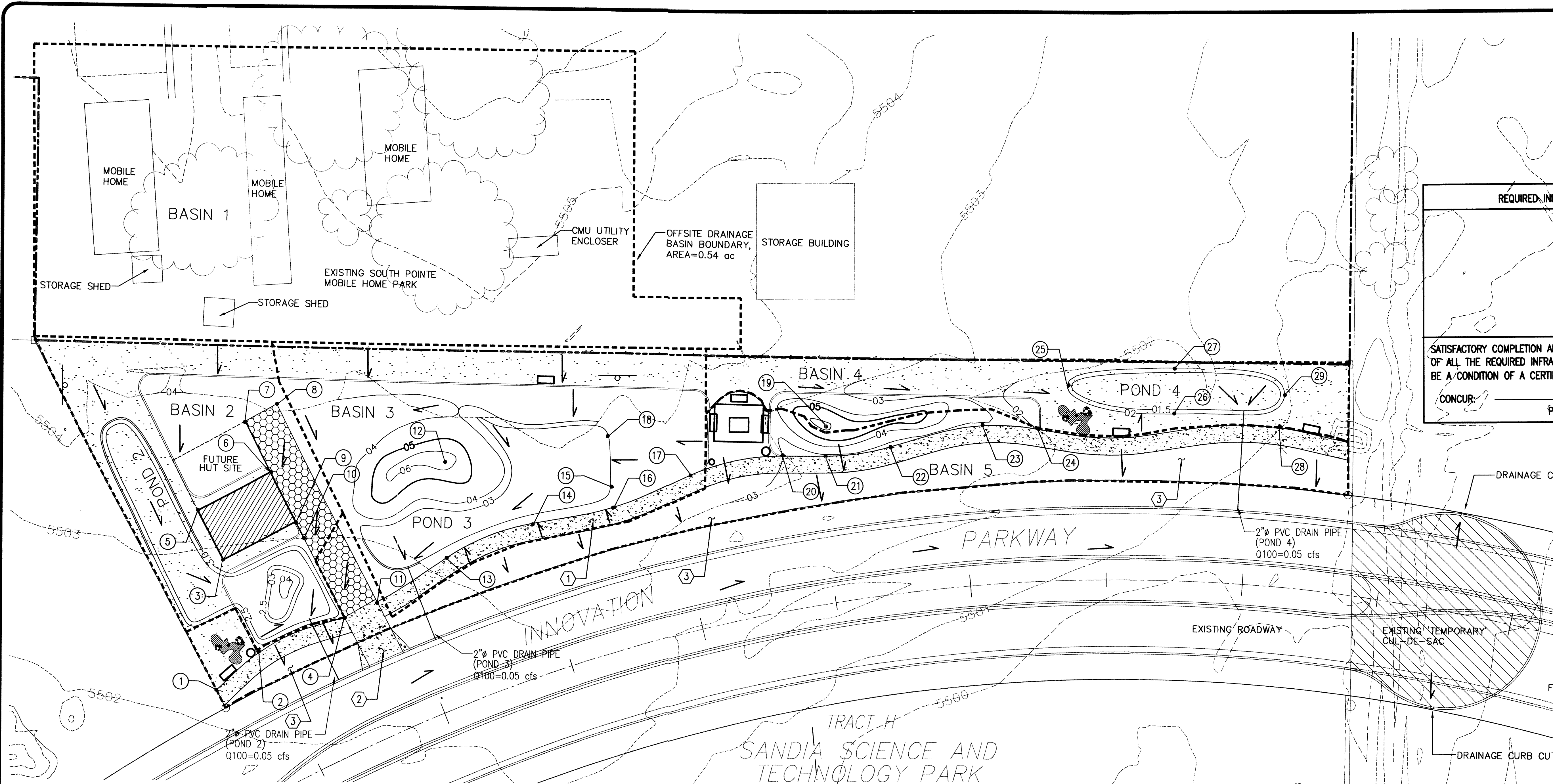

REQUIRED INFRASTRUCTURE

SATISFACTORY COMPLETION AND ACCEPTANCE OF ALL THE REQUIRED INFRASTRUCTURE SHALL BE A CONDITION OF A CERTIFICATE OF OCCUPANCY.

CONCUR: _____

PROPERTY OWNER

LEGAL DESCRIPTION

A certain tract of land situate within Section 33, Township 10 North, Range 4 East, New Mexico Principal Meridian, City of Albuquerque, Bernalillo County, New Mexico. Said tract being tract lettered 'G' of SANDIA SCIENCE AND TECHNOLOGY PARK, as the same is shown and designated on the plat thereof, filed in the office of the County Clerk of Bernalillo County, New Mexico on December 13, 2001 in Map Book 2001C, folio 324.

Tract G contains 0.7229 of an acre, more or less.

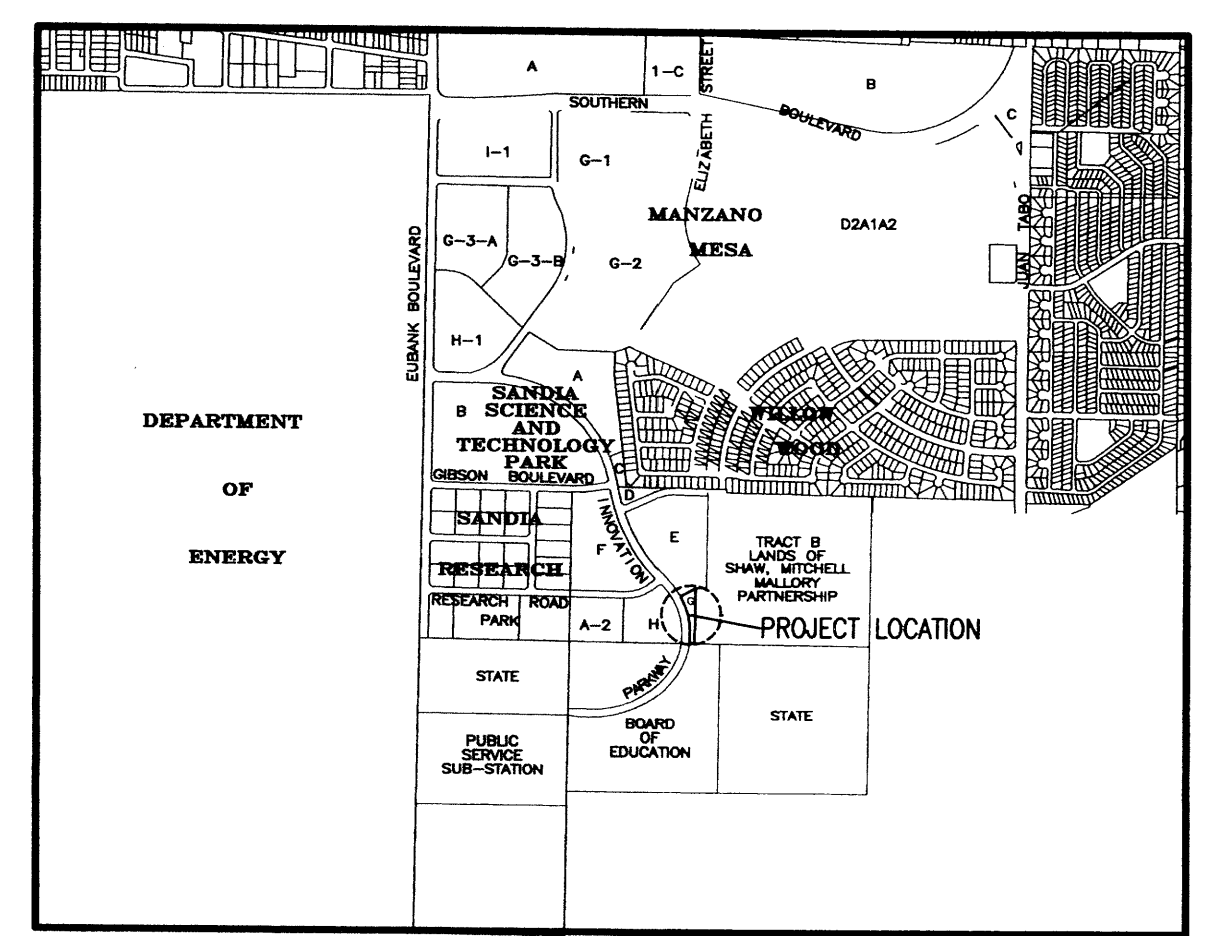

LOCATION MAP
ZONE ATLAS INDEX MAP No. M-21
 NOT TO SCALE

SITE DEVELOPMENT HYDROLOGICAL DATA

ONSITE DRAINAGE:

TOTAL BASIN AREA=0.63 ac
 ZONE 3
 DESIGN STORM EVENTS=100 yr.

EXISTING CONDITIONS:
 LAND TREATMENT: 0.63 ac 'C'
 $Q_{p100}=3.45 \text{ cfs/ac} \times 0.63 \text{ ac} = 2.17 \text{ cfs}$
 $Q_{p10}=2.00 \text{ cfs/ac} \times 0.63 \text{ ac} = 1.26 \text{ cfs}$

PROPOSED CONDITIONS:

DURING THE CONSTRUCTION AND PERMANENT PHASE OF THIS PROJECT THE COMBINED RUNOFF FOR BOTH ON-SITE AND OFF-SITE BASINS WILL BE CONVEYED VIA INNOVATION PARKWAY SOUTH TO A TEMPORARY CUL-DE-SAC, WHERE RUNOFF WILL DRAIN THROUGH TWO CURB CUTS LOCATED ON THE EAST AND WEST SIDE OF THE CUL-DE-SAC. PRESENTLY, LAND SOUTH OF THE PROJECT SITE IS UNDEVELOPED AND SLOPES NORTH TO SOUTH TO THE TUCERAS ARROYO. ULTIMATELY, INNOVATION PARKWAY WILL BE EXTENDED SOUTH AND WEST TO EUBANK BLVD., THUS, ELIMINATING THE CUL-DE-SAC. THIS FUTURE ROADWAY EXTENSION WILL INCLUDE NEW STORM DRAIN THAT WILL CONVEY THE RUNOFF FROM THE PROJECT SITE, AND ADJACENT OFF-SITE BASIN, TO THE SOUTH EUBANK STORM DRAIN.

100-YR RUNOFF FROM THIS SITE IS RESTRICTED TO 1.57 cfs/ac, PER THE MASTER DRAINAGE REPORT, FEBRUARY 8. THE PROPOSED PLAN USES DETENTION PONDING TO ATTENUATE FLOWS TO THIS LEVEL.

THREE DETENTION PONDS WILL MITIGATE ON-SITE RUNOFF. THE TOTAL RUNOFF WILL BE LIMITED TO 1.57 cfs/ac, OR APPROXIMATELY 1.0 CFS. OVER THE ENTIRE PROJECT AREA. MINOR OFFSITE FLOWS WILL PASS THROUGH THE PROJECT SITE UNMITIGATED. EACH POND WILL OUTFALL TO THE INNOVATION PARKWAY VIA 1-2" PVC PIPE.

BASIN 2/POND 2
 TOTAL AREA=0.17 ac
 LAND TREATMENT: 0.04 ac 'B', 0.11 ac 'C', 0.02 ac 'D'
 $\text{EXCESS PRECIPITATION (E)}=[(0.04 \text{ ac} \times 0.92 \text{ in.})+(0.11 \text{ ac} \times 1.29 \text{ in.})+(0.02 \text{ ac} \times 2.36 \text{ in.})]/0.17 \text{ ac} = 1.3 \text{ in.}$
 $\text{VOLUME (V}_{\text{vol}})=1.3 \text{ in.} \times 0.17 \text{ ac}/12 = 0.018 \text{ ac-ft.} = 784 \text{ cf.}$
 MAX. POND DEPTH = 0.5 ft.; POND AREA REQUIRED = 1568 sf.
 OUTFALL PIPE = 1-2" PVC PIPE
 $Q_{\text{ave}} = 0.05 \text{ cfs w/ } 0.5 \text{ ft. HEAD.}$

BASIN 3/POND 3
 TOTAL AREA=0.23 ac
 LAND TREATMENT: 0.17 ac 'B', 0.04 ac 'C', 0.02 ac 'D'
 $\text{EXCESS PRECIPITATION (E)}=[(0.17 \text{ ac} \times 0.92 \text{ in.})+(0.04 \text{ ac} \times 1.29 \text{ in.})+(0.02 \text{ ac} \times 2.36 \text{ in.})]/0.23 \text{ ac} = 1.1 \text{ in.}$
 $\text{VOLUME (V}_{\text{vol}})=1.1 \text{ in.} \times 0.23 \text{ ac}/12 = 0.021 \text{ ac-ft.} = 915 \text{ cf.}$
 MAX. POND DEPTH = 0.5 ft.; POND AREA REQUIRED = 1830 sf.
 OUTFALL PIPE = 1-2" PVC PIPE
 $Q_{\text{ave}} = 0.05 \text{ cfs w/ } 0.5 \text{ ft. HEAD.}$

BASIN 4/POND 4
 TOTAL AREA=0.12 ac
 LAND TREATMENT: 0.02 ac 'B', 0.10 ac 'C'
 $\text{EXCESS PRECIPITATION (E)}=[(0.02 \text{ ac} \times 0.92 \text{ in.})+(0.10 \text{ ac} \times 1.29 \text{ in.})]/0.12 \text{ ac} = 1.2 \text{ in.}$
 $\text{VOLUME (V}_{\text{vol}})=1.2 \text{ in.} \times 0.12 \text{ ac}/12 = 0.012 \text{ ac-ft.} = 518 \text{ cf.}$
 MAX. POND DEPTH = 0.5 ft.; POND AREA REQUIRED = 872 sf.
 OUTFALL PIPE = 1-2" PVC PIPE
 $Q_{\text{ave}} = 0.05 \text{ cfs w/ } 0.5 \text{ ft. HEAD.}$

BASIN 5
 TOTAL AREA=0.20 ac
 LAND TREATMENT: 0.02 ac 'B', 0.11 ac 'C', 0.07 ac 'D'
 $\text{EXCESS PRECIPITATION (E)}=[(0.02 \text{ ac} \times 0.92 \text{ in.})+(0.11 \text{ ac} \times 1.29 \text{ in.})+(0.07 \text{ ac} \times 2.36 \text{ in.})]/0.20 \text{ ac} = 1.2 \text{ in.}$
 $\text{VOLUME (V}_{\text{vol}})=1.2 \text{ in.} \times 0.20 \text{ ac}/12 = 0.020 \text{ ac-ft.} = 872 \text{ sf.}$
 MAX. POND DEPTH = 0.5 ft.; POND AREA REQUIRED = 872 sf.
 OUTFALL PIPE = 1-2" PVC PIPE
 $Q_{\text{ave}} = 0.05 \text{ cfs w/ } 0.5 \text{ ft. HEAD.}$

TOTAL FLOW PROJECT SITE = 0.05 + 0.05 + 0.05 + 0.78 = 0.93 cfs

OFF-SITE DRAINAGE:

TOTAL BASIN AREA=0.54 ac
 ZONE 3
 DESIGN STORM EVENTS=100 yr.

EXISTING CONDITIONS:
 LAND TREATMENT: 0.46 ac 'C', 0.08 ac 'D'
 $Q_{p100}=(3.45 \text{ cfs/ac} \times 0.46 \text{ ac})+(5.02 \text{ cfs/ac} \times 0.08 \text{ ac}) = 2.00 \text{ cfs}$

REFERENCES:
 CITY OF ALBUQUERQUE DEVELOPMENT PROCESS MANUAL, VOLUME 2, DESIGN CRITERIA, SECTION 22.2, HYDROLOGY.
 MASTER DEVELOPMENT PLAN, SANDIA SCIENCE & TECHNOLOGY PARK, APPROVED JUNE, 2001.
 MASTER DRAINAGE REPORT, SANDIA SCIENCE & TECHNOLOGY PARK, FEBRUARY 8, 2002.

EROSION CONTROL PLAN

EROSION CONTROL FOR THE ROUGH GRADING, PHASED DEVELOPMENT, AND CONSTRUCTION PHASE OF THE PROJECT WILL BE ACCOMPLISHED WITH SILT FENCING LOCATED ALONG THE NORTH AND WESTERN PERIMETER OF THE PROJECT AREA. EROSION CONTROL DURING THE PERMANENT PHASE WILL BE ACCOMPLISHED BY LANDSCAPING GROUND COVER, INCLUDING, GRAVEL, CONCRETE SIDEWALK, SOD TURF BLOCK, SOD, PLANTS AND TREES.

FLOOD HAZARD
 THE PROJECT SITE IS NOT LOCATED IN A FLOOD HAZARD AREA. PLEASE REFER TO ATTACHED FIRM MAP #350002 0037.

PLANNING HISTORY
 PLEASE REFER TO ATTACHED SANDIA SCIENCE & TECHNOLOGY PARK DRAINAGE MASTER PLAN.

SPOT ELEVATIONS

SPOT #	ELEVATION	NORTHING	EASTING
1	5502.5	N 1476076.09	E 1558620.70
2	5503.0	N 1476060.67	E 1558634.40
3	5503.61	N 1476073.98	E 1558667.91
4	5503.36	N 1476029.20	E 1558647.53
5	5503.61	N 1476083.32	E 1558685.57
6	5503.61	N 1476056.82	E 1558699.62
7	5503.74	N 1476066.18	E 1558717.30
8	5504.0	N 1476054.70	E 1558723.38
9	5503.61	N 1476047.42	E 1558681.99
10	5503.5	N 1476044.35	E 1558676.11
11	5503.5	N 1476017.23	E 1558653.27
12	5506.1	N 1475992.63	E 1558704.08
13	5503.5	N 1475991.61	E 1558669.30
14	5503.5	N 1475959.68	E 1558681.88
15	5503.0	N 1475931.17	E 1558695.21
16	5503.5	N 1475929.81	E 1558687.86
17	5503.5	N 1475902.15	E 1558699.37
18	5503.0	N 1475932.05	E 1558713.09
19	5506.1	N 1475851.98	E 1558717.21
20	5503.0	N 1475867.96	E 1558706.52
21	5503.0	N 1475852.03	E 1558706.62
22	5503.0	N 1475828.15	E 1558709.95
23	5502.42	N 1475794.22	E 1558717.34
24	5502.0	N 1475773.63	E 1558716.14
25	5502.0	N 1475762.72	E 1558731.30
26	5502.0	N 1475723.29	E 1558721.50
27	5502.0	N 1475723.02	E 1558737.62
28	5501.0	N 1475684.23	E 1558716.57
29	5502.0	N 1475682.77	E 1558727.99

KEYED NOTES

- SIDEWALK WITHIN BASIN 3 SHALL HAVE A CROSS SECTIONAL SLOPE OF 2.0% TO THE EAST. ALL OTHER SIDEWALK SHALL HAVE A CROSS-SECTIONAL SLOPE OF 2.0% TO THE WEST.
- MATCH TO STREET ELEVATIONS
- TIE TO EXISTING GROUND MAX. SLOPE = 3:1.

GENERAL NOTES

- SURVEY BASE INFORMATION TAKEN FROM ALTA/ACSM LAND TITLE SURVEY, TRACT G, SANDIA SCIENCE & TECHNOLOGY PARK, BY BOHANNAN HUSTON, DATED NOVEMBER, 2001.
- SEE SITE LAYOUT SHEET FOR EXISTING UTILITY LOCATIONS.

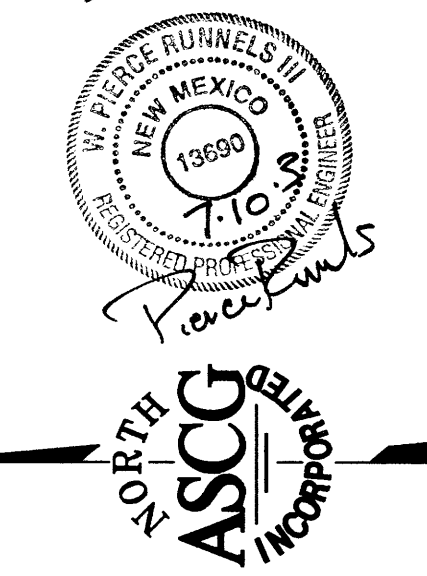
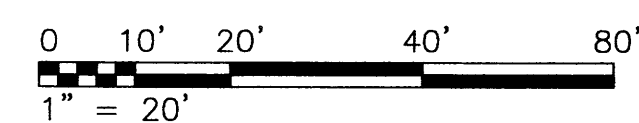

ASCG INCORPORATED
 ENGINEERS - ARCHITECTS - SURVEYORS - INSPECTION SERVICES
 6501 AMERICALS PARKWAY, SUITE 400
 ALBUQUERQUE, NEW MEXICO 87110-4372
 PHONE 505.247.0294 • FAX 505.242.4845

ENTERPRISE ELECTRICAL SERVICES INC.
 9708 BELL AVE. SE
 ALBUQUERQUE, NEW MEXICO 87123

SUMMIT CONSTRUCTION
 900 HAZELDINE AVE. SE
 ALBUQUERQUE, NEW MEXICO 87108

SANDIA SCIENCE AND TECHNOLOGY PARK

TELECOMMUNICATIONS DISTRIBUTION SYSTEM SANDIA SCIENCE AND TECHNOLOGY PARK GRADING AND DRAINAGE PLAN

REVISIONS
 NUMBER: DATE:

JOB NO:
 DATE:
 DRAWN BY: CAB
 CHECKED BY: PR
 DRAWING NO:
C-2
 SHEET OF

U:\SSTP\eng\DWL\GRADE\DRN_Plan.dwg CAB 03-25-03

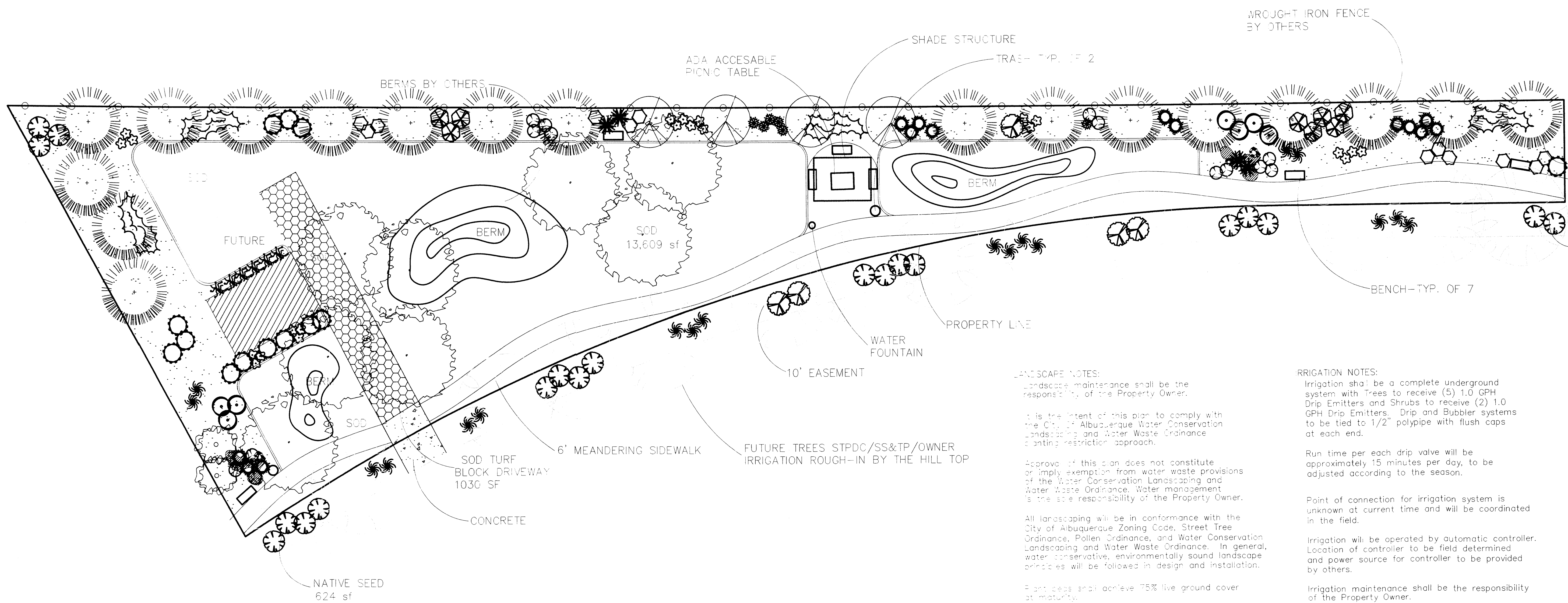

LANDSCAPE NOTES:
 Landscape maintenance shall be the responsibility of the Property Owner.
 It is the intent of this plan to comply with the City of Albuquerque Water Conservation Landscaping and Water Waste Ordinance planting restriction approach.
 Approval of this plan does not constitute or imply exemption from water waste provisions of the Water Conservation Landscaping and Water Waste Ordinance. Water management is the sole responsibility of the Property Owner.
 All landscaping will be in conformance with the City of Albuquerque Zoning Code, Street Tree Ordinance, Pollen Ordinance, and Water Conservation Landscaping and Water Waste Ordinance. In general, water conservative, environmentally sound landscape principles will be followed in design and installation.
 Plant beds shall achieve 75% live ground cover at maturity.
 Mesa Brown Gravel over Filter Fabric shall be placed in all landscape areas which are not designated to receive native seed.

IRRIGATION NOTES:
 Irrigation shall be a complete underground system with trees to receive (5) 1.0 GPH Drip Emitters and Shrubs to receive (2) 1.0 GPH Drip Emitters. Drip and Bubbler systems to be tied to 1/2" poly pipe with flush caps at each end.
 Run time per each drip valve will be approximately 15 minutes per day, to be adjusted according to the season.
 Point of connection for irrigation system is unknown at current time and will be coordinated in the field.
 Irrigation will be operated by automatic controller. Location of controller to be field determined and power source for controller to be provided by others.
 Irrigation maintenance shall be the responsibility of the Property Owner.

LANDSCAPE CALCULATIONS

NET LANDSCAPE AREA	
TOTAL LOT AREA	27,577 square feet
TOTAL BUILDINGS AREA	600 square feet
NET LOT AREA	26,977 square feet
OFFSITE AREA	4,730 square feet
TOTAL LANDSCAPE PROVIDED	27,872 square feet
TOTAL SOD REQUIRED (50% OF NET)	13,488 square feet
TOTAL SOD PROVIDED	13,609 square feet
TOTAL BED PROVIDED	9,427 square feet
TOTAL NATIVE SEED PROVIDED	4,836 square feet
TOTAL TREES REQUIRED (1 PER 1500 SF OF LANDSCAPE AREA)	19
TOTAL TREES PROVIDED	32

The Hilltop

LANDSCAPE ARCHITECTS & CONTRACTORS
 Cont. Lic. #26458
 7909 Edith N.E.
 Albuquerque, NM 87184
 Ph. (505) 898-9690
 Fax (505) 898-7737
 iw@hilltoplandscaping.com
THE HILLTOP expressly reserves the common law copyright and other property rights in these plans. These plans are not to be reproduced, changed or copied in any manner whatsoever, nor are they to be assigned to any third party without obtaining the express written permission and consent of THE HILLTOP.

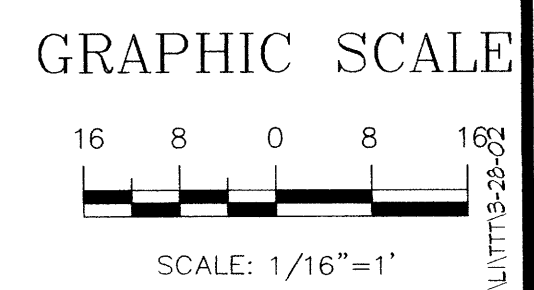

PLANT LEGEND

- HONEY LOCUST (M) 8
2 1/2" Cal.
- AUSTRIAN PINE (M) 18
8' MIN.
- REDBUD (M) 4
1-1/2" Cal.
- CRABAPPLE (M) 2
15 Gal.
- FOUNTAIN GRASS (L) 18
1 Gal.
- COTONEASTER (M) 5
1 Gal.
- RED YUCCA (L) 4
1 Gal.
- PHOTINIA (M) 13
1 Gal.
- CREEPING MAHONIA (M) 6
1 Gal.
- BLUE MIST (L) 6
1 Gal.
- INDIAN HAWTHORN (M) 8
1 Gal.
- CHAMISA (L) 20
1 Gal.
- AUTUMN SAGE (L) 12
1 Gal.
- POTENTILLA (M) 22
1 Gal.
- RUSSIAN SAGE (L) 7
1 Gal.
- SCOTCH BROOM (M) 14
1 Gal.
- JUNIPER (M) 12
1 Gal.
Symbol indicates three plants.
- WILDFLOWER (L) 14
1 Gal.
- MESA BROWN GRAVEL WITH FILTER FABRIC 4" DEEP
- SOD SEE SECTION 1010 OF COA SPEC.
- 6"x6" MOW CURB SEE COA STANDARD DWG-2726
- OVERSIZED GRAVEL & 6 BOULDERS

ASCG
 INCORPORATED
ENGINEERS - ARCHITECTS - SURVEYORS - INSPECTION SERVICES
 1851 AVENUE G, SUITE 400
 ALBUQUERQUE, NEW MEXICO 87110-5372
 PHONE 505.247.0284 FAX 505.262.4645

ENTERPRISE ELECTRICAL SERVICES INC.
 9708 BELL AVE. SE
 ALBUQUERQUE, NEW MEXICO 87123

SUMMIT CONSTRUCTION
 NATIVE SEED
 900 HAZELDINE AVE. SE
 ALBUQUERQUE, NEW MEXICO 87108

SANDIA SCIENCE AND TECHNOLOGY PARK
 1505 INNOVATION S.E.
 ALBUQUERQUE, N. M.

TELECOMMUNICATIONS DISTRIBUTION SYSTEM
 AT THE SANDIA SCIENCE AND TECHNOLOGY PARK
 SITE PLAN
 LANDSCAPE

REVISIONS

NUMBER:	DATE:

JOB NO.:
 DATE: APRIL 4, 2003
 DRAWN BY:
 CHECKED BY:
L-1
 SHEET OF

J:\551P\2003\DWG\LUTTI3-23-03

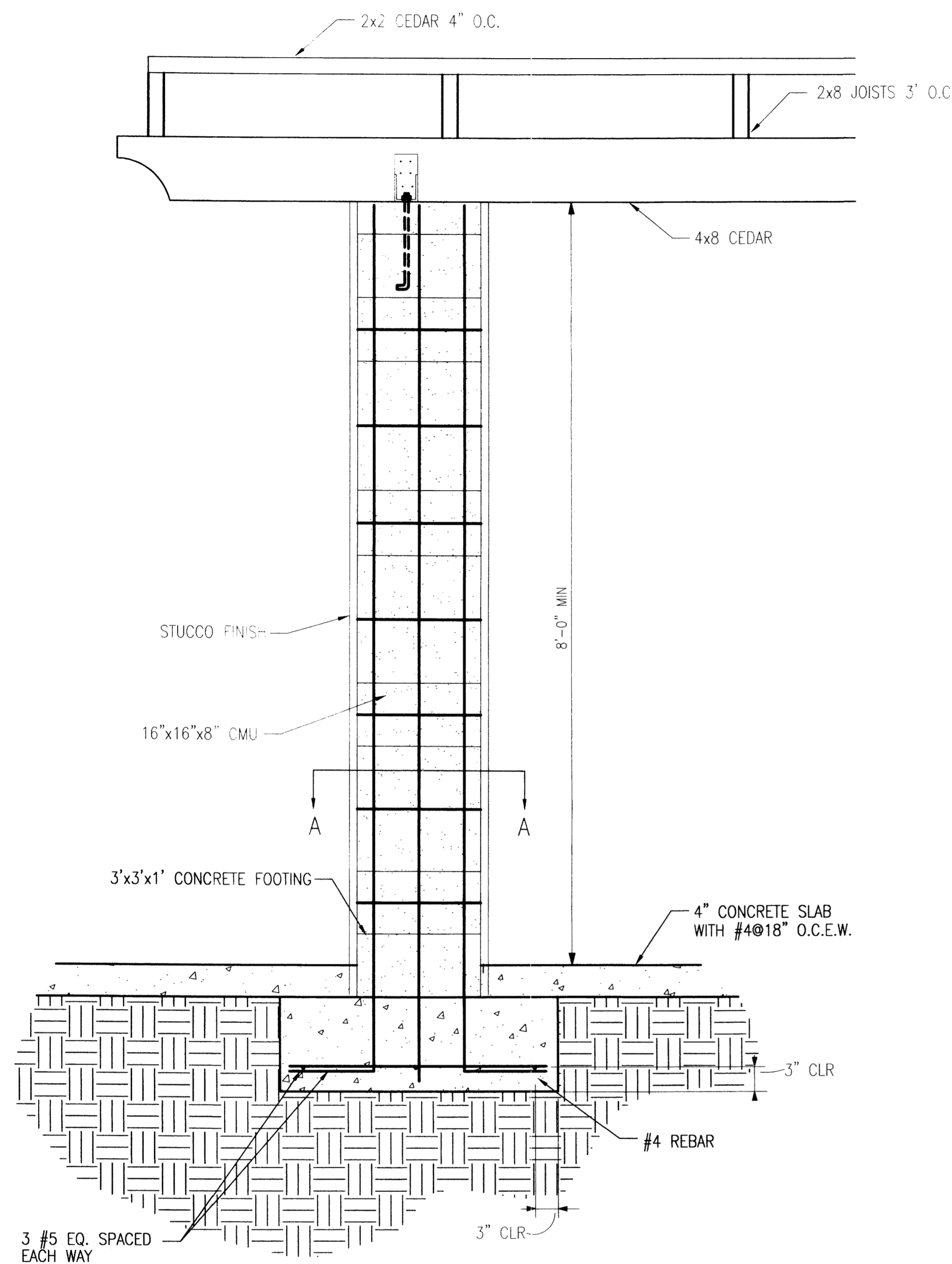

SHADE STRUCTURE DETAIL

SCALE: 1/2"=1'-0"

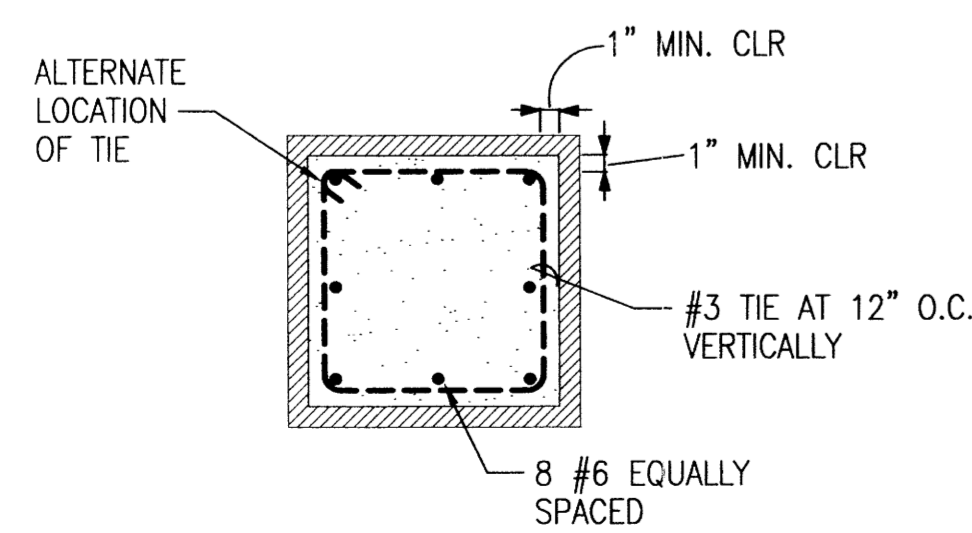

SECTION 'A'

1/2"=1'-0"

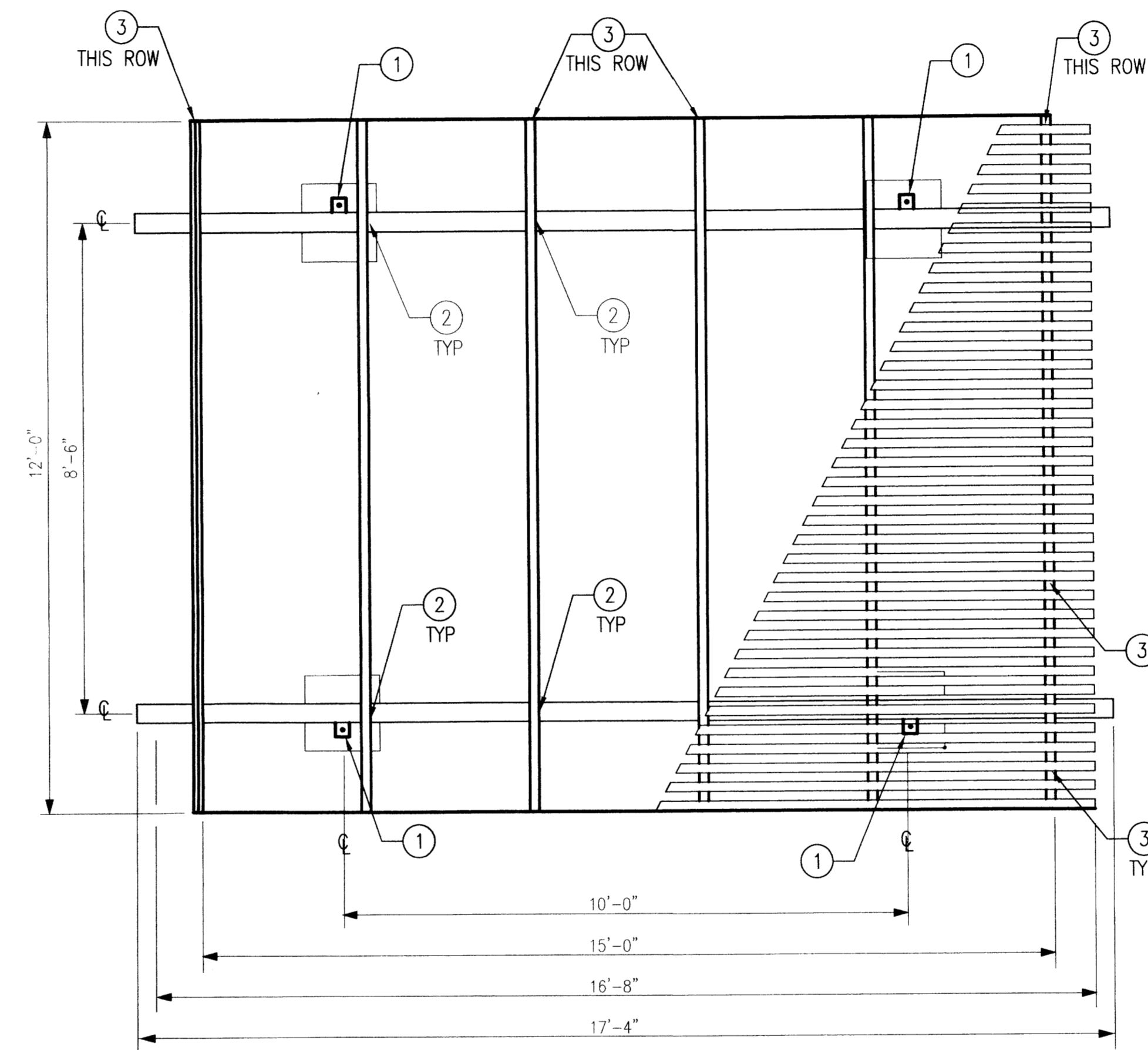

SHADE STRUCTURE PLAN

SCALE: 1/2"=1'-0"

GENERAL NOTES

- A REFER TO GENERAL NOTES SHEET S-1 FOR REQUIREMENTS.
- B WESTERN CEDAR MINIMUM GRADE:
2x2 NO.2
2x8 NO.2
4x8 NO.2

KEYED NOTES

- 1 HOLD DOWN-4 TOTAL SIMPSON HDA/HD TYPE WITH 1 1/2" CARBON STEEL HILTI KWIK BOLT 11 WITH MINIMUM EMBEDMENT 6" OR EQUIVALENT OR USE SIMPSON HGLB (BEAM SEAT) TYPE OR EQUIVALENT.
- 2 FRAMING ANGLE-12 TOTAL SIMPSON A35 TYPE MINIMUM 18 GAUGE OR EQUIVALENT.
- 3 FRAMING ANGLE 144 TOTAL SIMPSON A34 TYPE MINIMUM 18 GAUGE OR EQUIVALENT.

ASCG
INCORPORATED
ENGINEERS - ARCHITECTS - SURVEYORS - INSPECTION SERVICES
8501 AMERICAS PARKWAY NE, SUITE 400
ALBUQUERQUE, NEW MEXICO 87123
PHONE 505.271.2524 FAX 505.242.4545

ENTERPRISE ELECTRICAL
SERVICES INC.
8708 BELL AVE. SE
ALBUQUERQUE, NEW MEXICO
87123

SUMMIT CONSTRUCTION
900 HAZELDINE AVE. SE
ALBUQUERQUE, NEW MEXICO
87106

**SANDIA SCIENCE AND
TECHNOLOGY PARK
1505 INNOVATION S.E.
ALBUQUERQUE, N. M.**

TELECOMMUNICATIONS DISTRIBUTION SYSTEM
AT THE SANDIA SCIENCE AND TECHNOLOGY PARK
**SHADE STRUCTURE
PLAN AND DETAIL**

REVISIONS

NUMBER: DATE:

JOB NO: 20288

DATE: APRIL 4, 2003

DRAWN BY: TLM

CHECKED BY: RES

DRAWING NO:

S2
SHEET OF

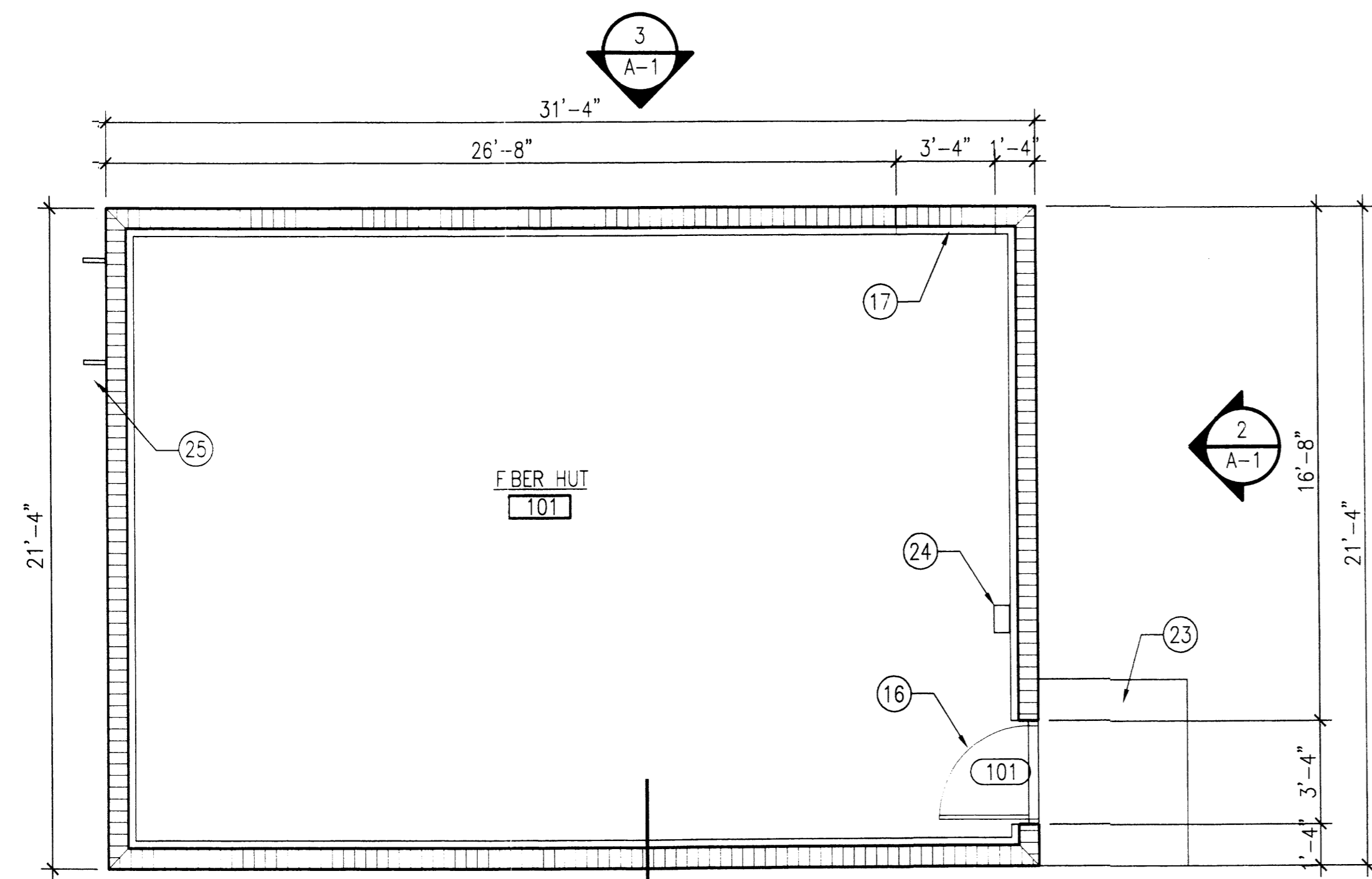

1 FLOOR PLAN
SCALE: 1/4"=1'-0"

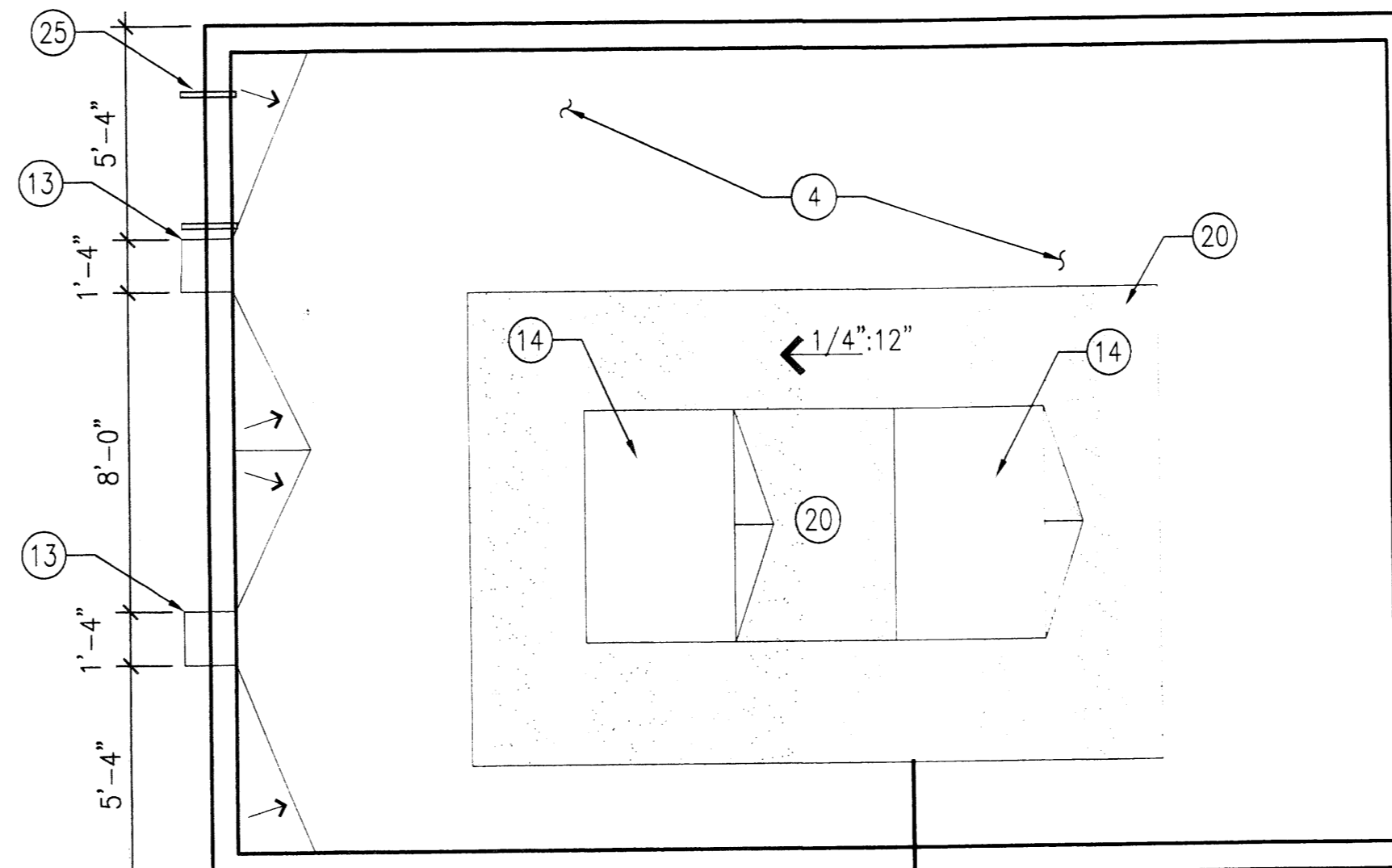

4 ROOF PLAN
SCALE: 1/4"=1'-0"

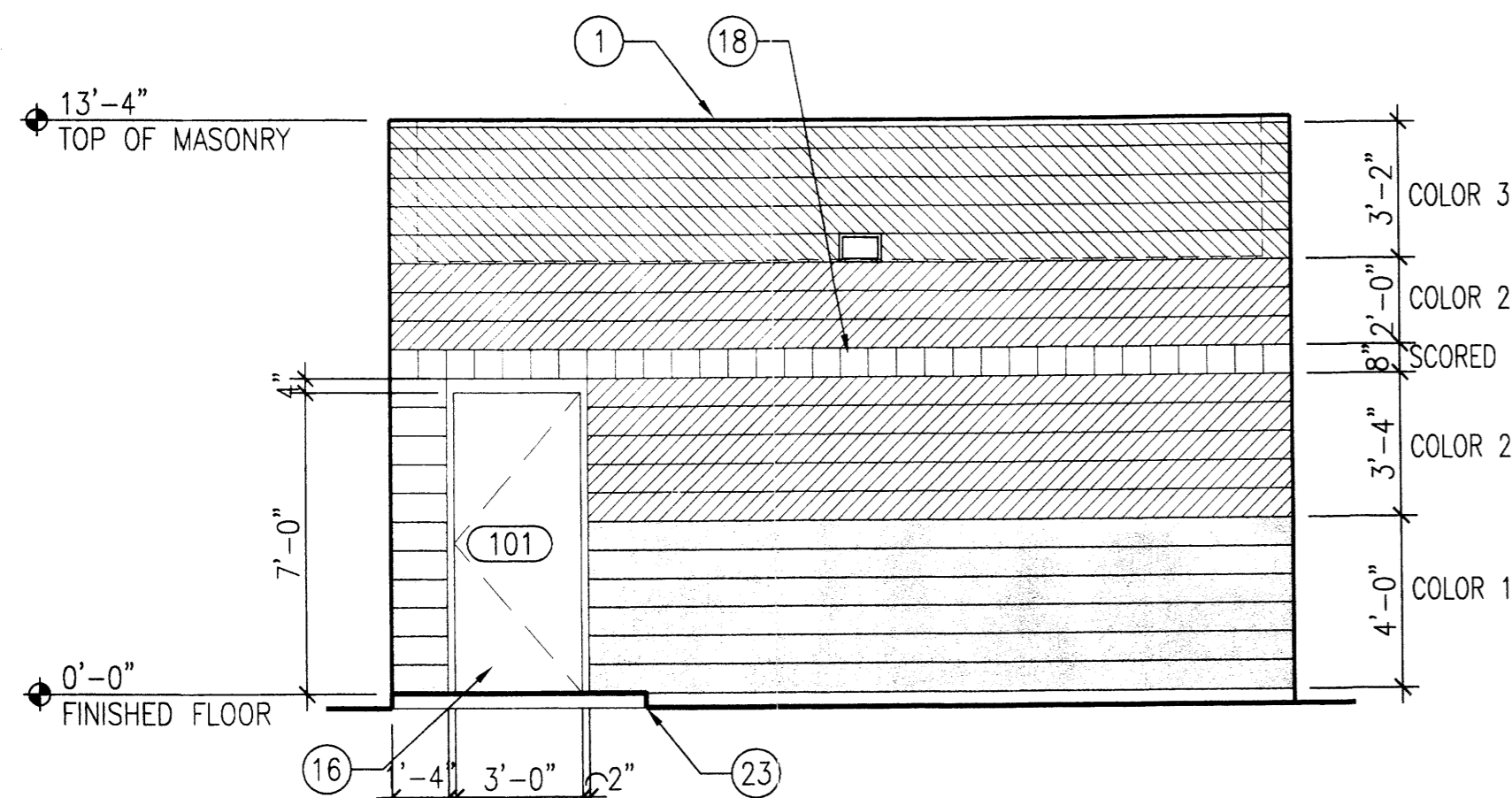

2 FRONT ELEVATION
SCALE: 1/4"=1'-0"

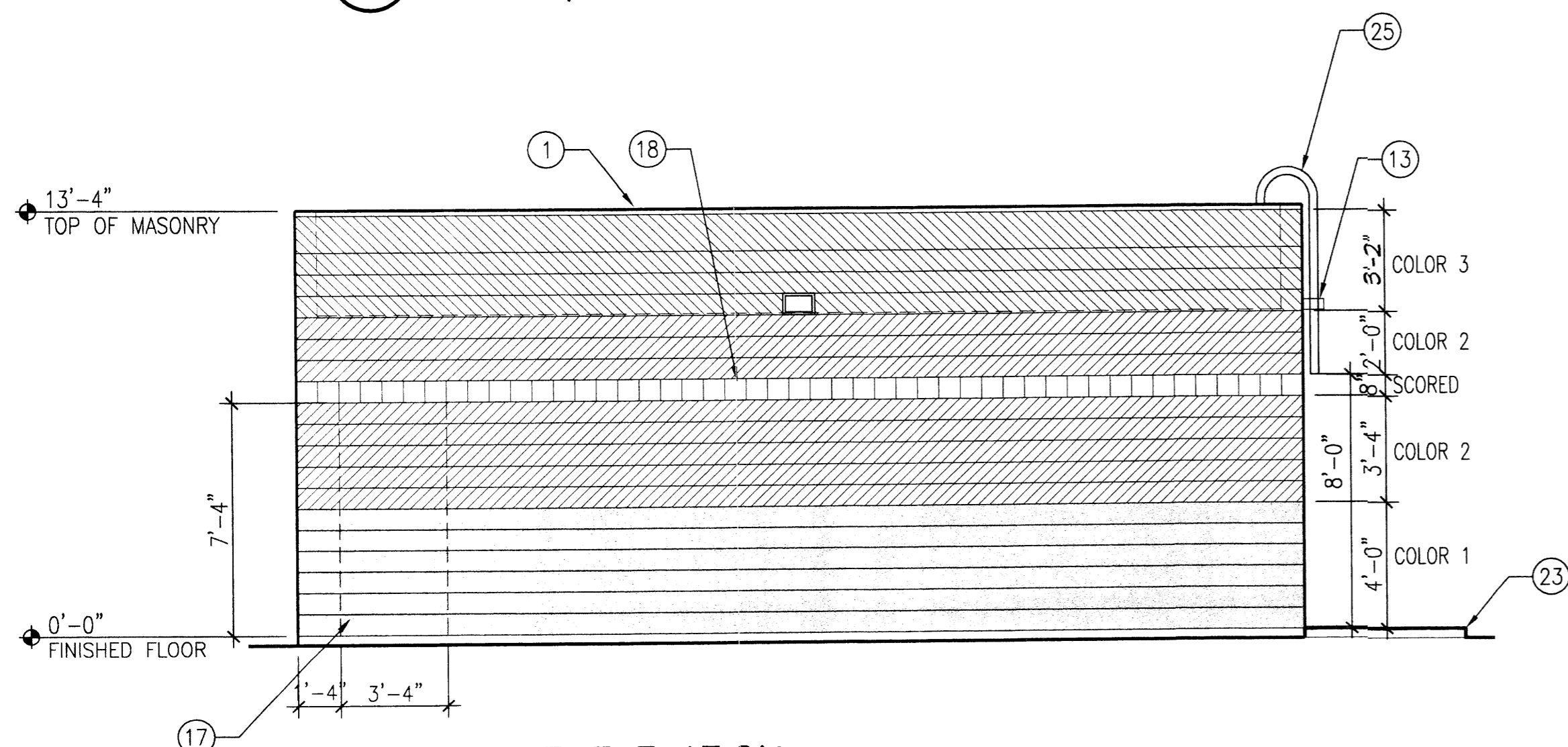

3 SIDE ELEVATION
SCALE: 1/4"=1'-0"

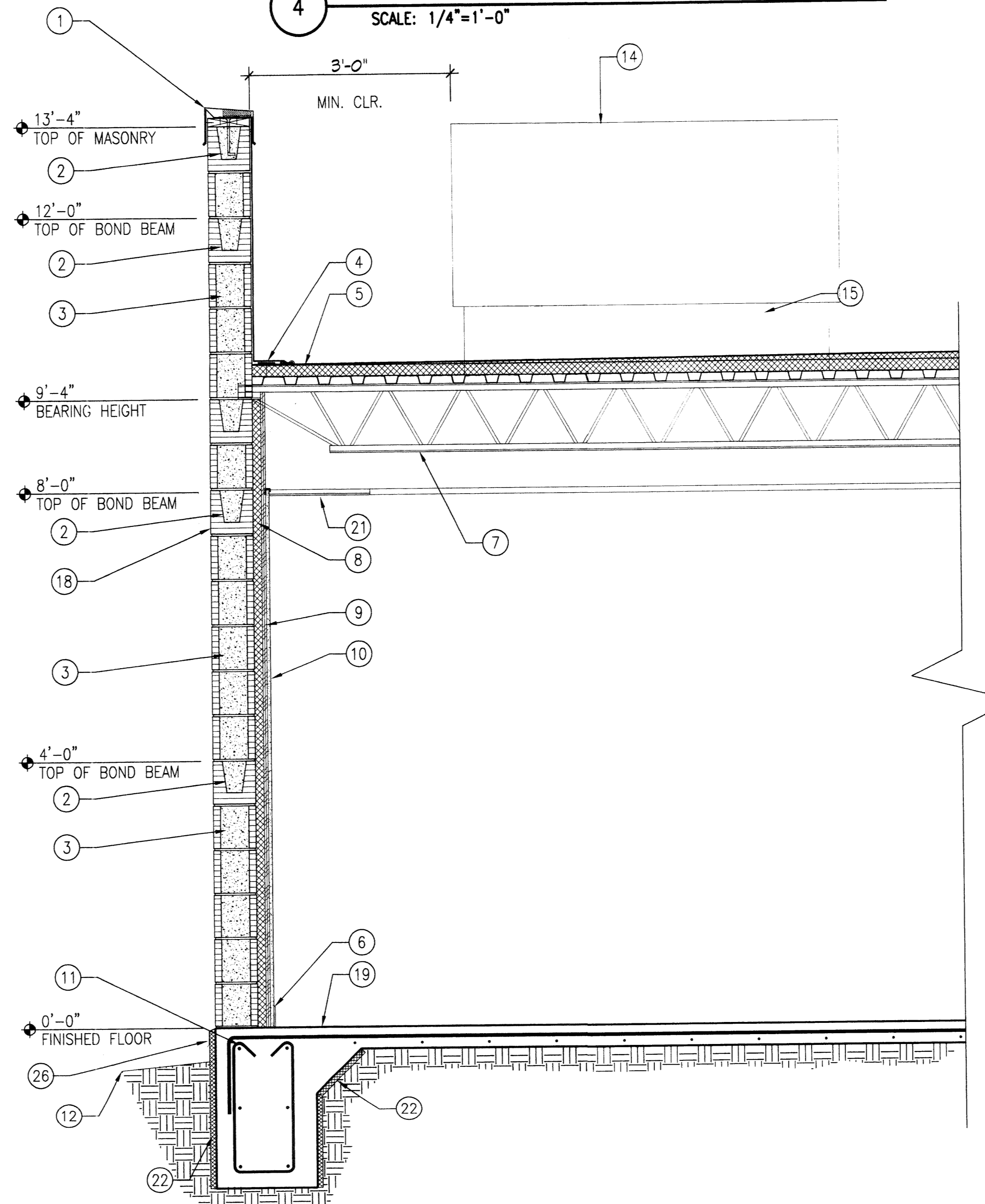

5 WALL SECTION - TYPICAL
SCALE: 3/4"=1'-0"

KEYED NOTES

- 1 METAL COPING, PAINTED
- 2 8" CONCRETE BOND BEAM
- 3 8" CONCRETE MASONRY UNIT, SOLID GROUTED, REINFORCED
- 4 SINGLE MEMBRANE ROOFING SYSTEM. WRAP UNDER METAL COPING
- 5 TAPERED RIGID INSULATION, MINIMUM 4" THICK
- 6 4" VINYL BASE
- 7 OPEN WEB STEEL JOIST, PAINTED (SEE STRUCTURAL)
- 8 Z FURRING CHANNEL WITH RIGID INSULATION R-19
- 9 5/8" GYPSUM BOARD TO 8'-0" A.F.F. PAINT
- 10 3/4" PLYWOOD TO ROOF DECK, PAINT
- 11 FOUNDATION SYSTEM
- 12 FINISHED GRADE, SLOPE AWAY FROM BUILDING
- 13 8"x16" GALVANIZED METAL SCUPPER, 22 GA.
- 14 ROOF TOP UNIT (SEE MECHANICAL)
- 15 12" CURB (SEE MECHANICAL)
- 16 3'-0" x 7'-0" HOLLOW METAL INSULATED DOOR WITH HOLLOW METAL FRAME, PAINTED. PROVIDE DEAD BOLT, PULL HANDLES BOTH SIDES AND CLOSER
- 17 LOCATION OF FUTURE DOOR
- 18 SMOOTH SCORED 8" CMU WITH INTERGRATED COLOR. COLOR SELECTION TO BE MADE IN FIELD
- 19 CONCRETE SLAB WITH SHEET VINYL FLOORING
- 20 MEMBRANE WALKPAD
- 21 LADDER RACK, SEE ELECTRICAL
- 22 1" PERIMETER INSULATION
- 23 5'-0" x 6'-0" CONCRETE STOOP
- 24 SEMI RECESS FIRE EXTINGUISHER CABINET AND FIRE EXTINGUISHER.
- 25 ROOF ACCESS LADDER.
- 26 METAL FLASHING MATCH CMU COLOR.

LEGEND

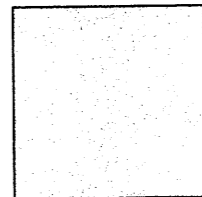
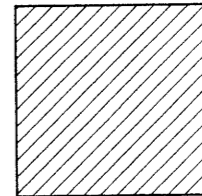
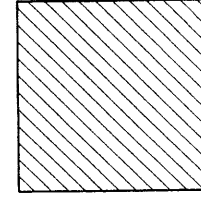
-  CONCRETE MASONRY UNIT - SPLIT FACE COLOR 1. COLOR SELECTION TO BE MADE IN FIELD
-  CONCRETE MASONRY UNIT - SPLIT FACE COLOR 2. COLOR SELECTION TO BE MADE IN FIELD
-  CONCRETE MASONRY UNIT - SPLIT FACE COLOR 3. COLOR SELECTION TO BE MADE IN FIELD

STATE OF NEW MEXICO
DAVID W. THIBERT
REGISTERED ARCHITECT
No. 1004
David W. Thibert
July 11, 2003

ASCG
INCORPORATED
ENGINEERS - ARCHITECTS - SURVEYORS - INSPECTION SERVICES
6500 AMERICAS PARKWAY NE, SUITE 400
ALBUQUERQUE, NEW MEXICO 87123
PHONE 505.247.0284 FAX 505.242.2845

ENTERPRISE ELECTRICAL SERVICES INC.
9708 BELL AVE. SE
ALBUQUERQUE, NEW MEXICO 87123

SUMMIT CONSTRUCTION
900 HAZELDINE AVE. SE
ALBUQUERQUE, NEW MEXICO 87106

SANDIA SCIENCE AND TECHNOLOGY PARK
1505 INNOVATION S.E.
ALBUQUERQUE, N. M.

TELECOMMUNICATIONS DISTRIBUTION SYSTEM
AT THE SANDIA SCIENCE AND TECHNOLOGY PARK
FLOOR PLAN, ROOF PLAN, ELEVATIONS AND SECTION

REVISIONS

NUMBER	DATE

JOB NO: 20288
DATE: APRIL 4, 2003
DRAWN BY: BB
CHECKED BY: JZ
DRAWING NO: A-1
SHEET 1 OF

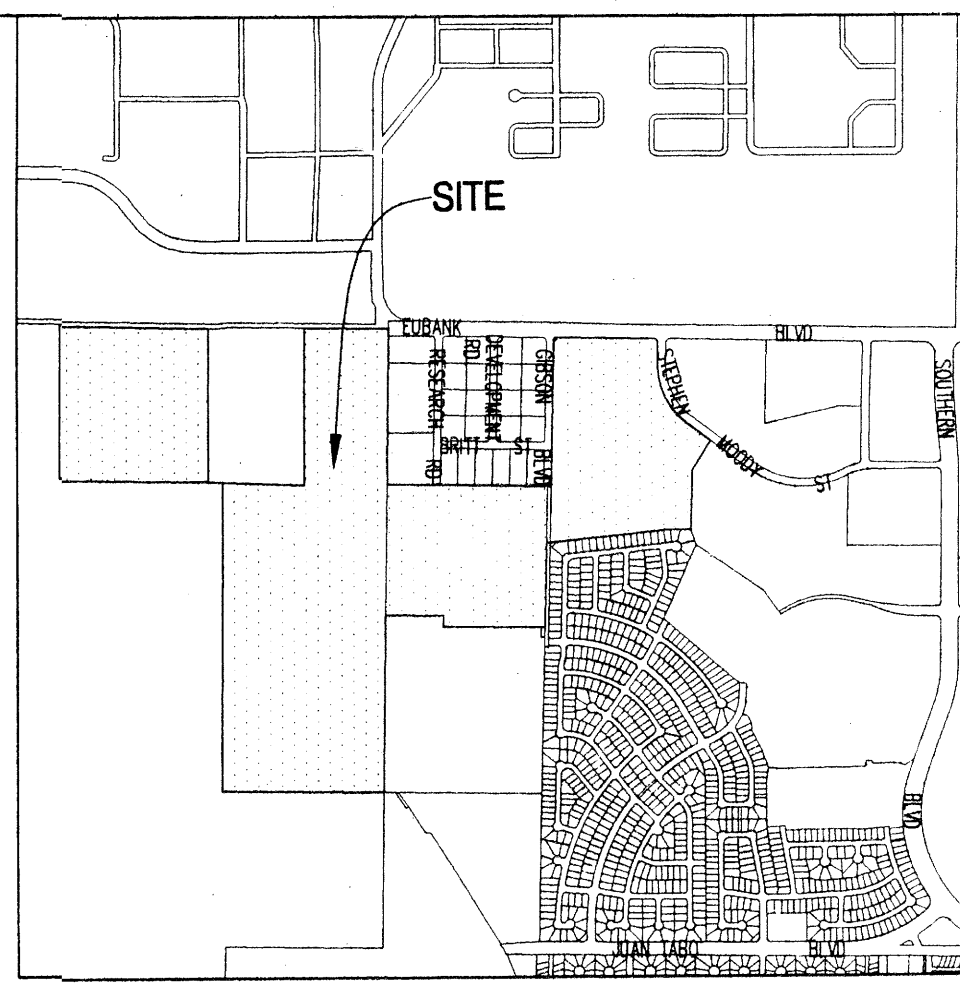
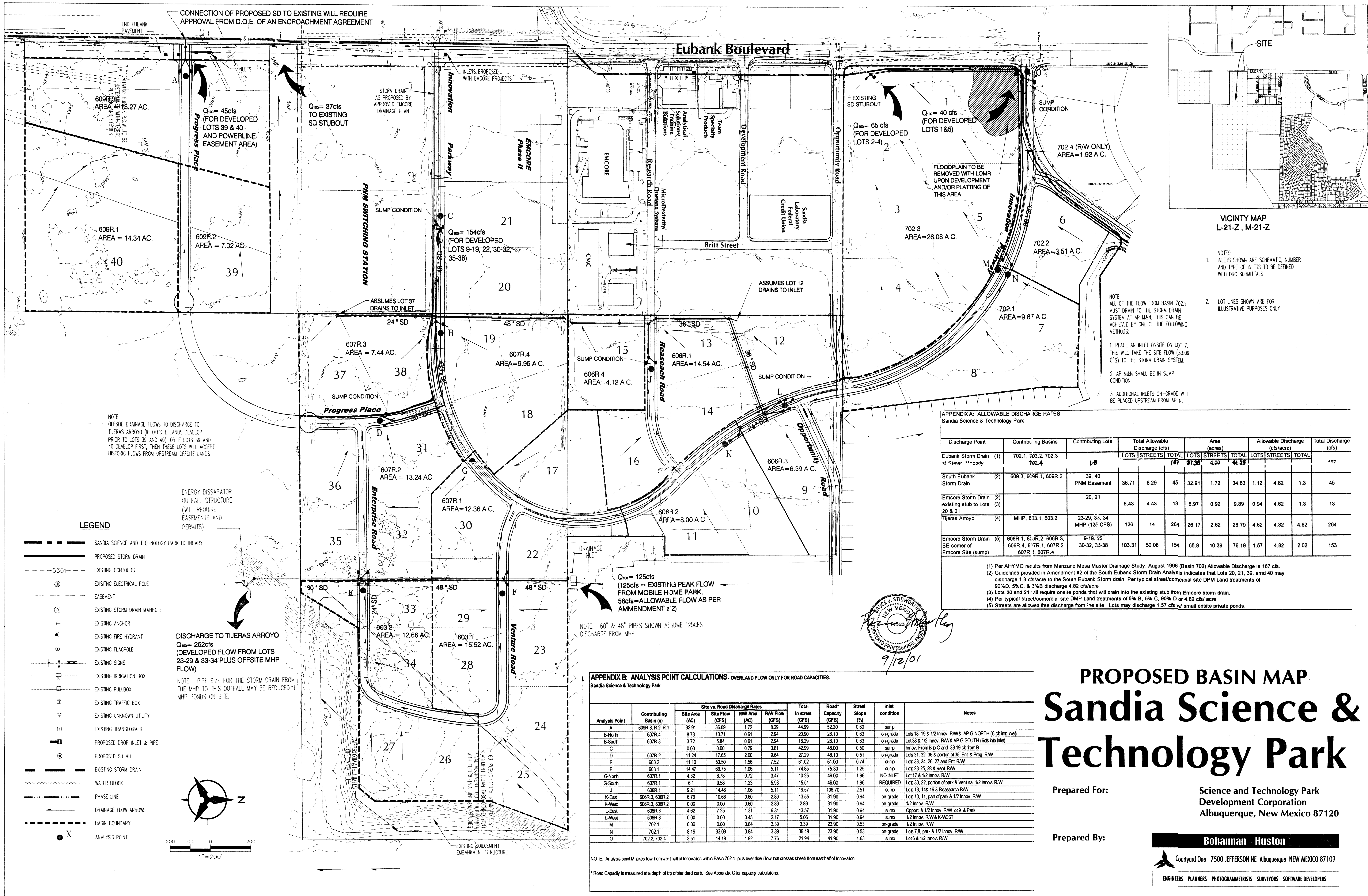

VICINITY MAP
L-21-Z, M-21-Z

NOTES:
1. INLETS SHOWN ARE SCHEMATIC, NUMBER AND TYPE OF INLETS TO BE DEFINED WITH DRC SUBMITTALS
2. LOT LINES SHOWN ARE FOR ILLUSTRATIVE PURPOSES ONLY

NOTE:
ALL OF THE FLOW FROM BASIN 702.1 MUST DRAIN TO THE STORM DRAIN SYSTEM AT AP M&N. THIS CAN BE ACHIEVED BY ONE OF THE FOLLOWING METHODS:
1. PLACE AN INLET ON SITE ON LOT 7. THIS WILL TAKE THE SITE FLOW (33.09 CFS) TO THE STORM DRAIN SYSTEM.
2. AP M&N SHALL BE IN SUMP CONDITION.
3. ADDITIONAL INLETS ON-GRADE WILL BE PLACED UPSTREAM FROM AP N.

APPENDIX A: ALLOWABLE DISCHARGE RATES
Sandia Science & Technology Park

Discharge Point	Contributing Basins	Contributing Lots	Total Allowable Discharge (cfs)			Area (acres)			Allowable Discharge (cfs/acre)			Total Discharge (cfs)
			LOTS	STREETS	TOTAL	LOTS	STREETS	TOTAL	LOTS	STREETS	TOTAL	
Eubank Storm Drain at Steve McCoy	702.1, 702.2, 702.3	1-8	167	97.36	4.00	41.38						167
South Eubank Storm Drain	609.3, 609R.1, 609R.2	39, 40 PNM Easement	36.71	8.29	45	32.91	1.72	34.63	1.12	4.82	1.3	45
Emcore Storm Drain (2) existing stub to Lots 20 & 21		20, 21	8.43	4.43	13	8.97	0.92	9.89	0.94	4.82	1.3	13
Tijeras Arroyo	MHP, 603.1, 603.2	23-29, 31, 34 MHP (125 CFS)	126	14	264	26.17	2.62	28.79	4.82	4.82	4.82	264
Emcore Storm Drain SE corner of Emcore Site (sump)	606R.1, 606R.2, 606R.3, 606R.4, 607R.1, 607R.2, 607R.3, 607R.4	9-19, 22, 30-32, 35-38	103.31	50.08	154	65.8	10.39	76.19	1.57	4.82	2.02	153

(1) Per AHYMO results from Manzano Mesa Master Drainage Study, August 1996 (Basin 702) Allowable Discharge is 167 cfs.
(2) Guidelines provided in Amendment #2 of the South Eubank Storm Drain Analysis indicates that Lots 20, 21, 39, and 40 may discharge 1.3 cfs/acre to the South Eubank Storm Drain. Per typical street/commercial site DPM Land treatments of 90% D, 5% C, & 5% B discharge 4.82 cfs/acre.
(3) Lots 20 and 21 - all require onsite ponds that will drain into the existing stub from Emcore storm drain.
(4) Per typical street/commercial site DPM Land treatments of 5% B, 5% C, 90% D or 4.82 cfs/acre.
(5) Streets are allowed free discharge from the site. Lots may discharge 1.57 cfs w/ small onsite private ponds.

APPENDIX B: ANALYSIS POINT CALCULATIONS - OVERLAND FLOW ONLY FOR ROAD CAPACITIES.
Sandia Science & Technology Park

Analysis Point	Contributing Basin (e)	Site vs. Road Discharge Rates				Total In street (CFS)	Road Capacity (CFS)	Street Slope (%)	Inlet condition	Notes
		Site Area (AC)	Site Flow (CFS)	RW Area (AC)	RW Flow (CFS)					
A	606R.3, R.2, R.1	32.91	36.69	1.72	8.29	44.99	52.20	0.50	sump	
B-North	607R.4	8.73	13.71	0.81	2.94	20.50	26.10	0.63	on-grade	Lots 18, 19 & 1/2 Innov. RW & AP G-NORTH (5 cfs into inlet)
B-South	607R.3	3.72	5.84	0.61	2.94	18.29	26.10	0.63	on-grade	Lot 38 & 1/2 Innov. RW & AP G-SOUTH (6 cfs into inlet)
C		0.00	0.00	0.79	3.81	42.99	46.00	0.50	sump	Innov. From B to C and 39.19 cfs from B
D	607R.2	11.24	17.65	2.00	9.64	27.29	48.10	0.51	on-grade	Lot 31, 32, 36 & portion of 35, Ent & Prog. RW
E	603.2	11.10	53.50	1.56	7.52	61.02	61.00	0.74	sump	Lot 33, 34, 26, 27 and Ent RW
F	603.1	14.47	69.75	1.06	5.11	74.85	75.30	1.25	sump	Lot 23-25, 28 & Vent RW
G-North	607R.1	4.32	6.78	0.72	3.47	10.25	46.00	1.96	NO INLET	Lot 17 & 1/2 Innov. RW
G-South	607R.1	6.1	9.58	1.23	5.93	15.51	46.00	1.96	REQUIRED	Lot 30, 22, portion of park & Ventura, 1/2 Innov. RW
J	606R.1	9.21	14.46	1.06	5.11	19.57	106.70	2.51	sump	Lot 13, 14, 15 & Research RW
K-East	606R.3, 606R.2	6.79	10.66	0.60	2.89	13.55	31.90	0.94	on-grade	Lot 10, 11, part of park & 1/2 Innov. RW
K-West	606R.3, 606R.2	0.00	0.00	0.60	2.89	2.89	31.90	0.94	on-grade	1/2 Innov. RW
L-East	606R.3	4.62	7.25	1.31	6.31	13.57	31.90	0.94	sump	Oppert & 1/2 Innov. RW, lot 9 & Park
L-West	606R.3	0.00	0.00	0.45	2.17	5.06	31.90	0.94	sump	1/2 Innov. RW & K-WEST
M	702.1	0.00	0.00	0.84	3.39	3.39	23.90	0.53	on-grade	1/2 Innov. RW
N	702.1	8.19	33.09	0.84	3.39	36.48	23.90	0.53	on-grade	Lot 7.8, park & 1/2 Innov. RW
O	702.2, 702.4	3.51	14.18	1.92	7.76	21.94	41.90	1.63	sump	Lot 6 & 1/2 Innov. RW

NOTE: Analysis point M takes flow from west half of Innovation within Basin 702.1 plus over flow (flow that crosses street) from east half of Innovation.

* Road Capacity is measured at a depth of 1 ft of standard curb. See Appendix C for capacity calculations.

PROPOSED BASIN MAP Sandia Science & Technology Park

Prepared For:

Science and Technology Park
Development Corporation
Albuquerque, New Mexico 87120

Prepared By:

Bohannon Huston
 Courtyard One 7500 JEFFERSON NE Albuquerque NEW MEXICO 87109
 ENGINEERS PLANNERS PHOTOGRAMMETRISTS SURVEYORS SOFTWARE DEVELOPERS