

2696131824
 6519387
 Page 2 of 2
 68/38/2696 08-51A
 Bk-2686C Pg-265

TRUMBULL AVENUE, S. E.
 (6 0' R. O. W.)

PLAT OF
**TRACTS A-1 & A-2, BLOCK 5,
 ESPERANZA ADDITION**

A REPLAT OF TRACT A, BLOCK 5, ESPERANZA ADDITION
 WITHIN NW 1/4, SECTION 25, T.10N., R.3E., N.M.P.M.,
 ALBUQUERQUE, BERNALILLO COUNTY, NEW MEXICO

JUNE 2006

COUNTY CLERK RECORDING LABEL HERE

ACS MONUMENT "6-K18A"
 x = 398,545.00
 y = 1,483,892.49
 Ground-to-grid:
 0.99966021
 Delta Alpha:
 -00°11'42"
 NMSP CENTRAL
 ZONE, NAD 1927

LOT 1

LOT 13

BLOCK 5
 ESPERANZA ADDITION
 (REC. 7/30/1946 VOLUME C, FOLIO 56)

BLOCK 5, ESPERANZA ADDITION
 (REC. 7/30/1946 VOLUME C, FOLIO 56)

N. 42.33' LOT 2

LOT 14

(S 89° 46' 00" E)
 (S 89° 07' 41" E)

(N 00° 14' 00" E)
 (N 00° 24' 50" E)
 (110.00')
 110.00'

SET RBR

5' PUBLIC UTILITY EASEMENT (SEE NOTE 4)

10' PUBLIC UTILITY EASEMENT (SEE NOTE 5)

(S 89° 46' 00" E)
 (S 89° 03' 08" E)

N. 10' LOT 15

(135.00')
 135.21'

20.00'
 14.89'
 16.00'
 123.76'

SET RBR

TRACT A - 2
 0.4130 ac.

TRACT A - 1
 0.5657 ac.

SAN MATEO BOULEVARD, S. E.
 (100' R. O. W.)

ORTIZ DRIVE, S. E.
 (60' R. O. W.)

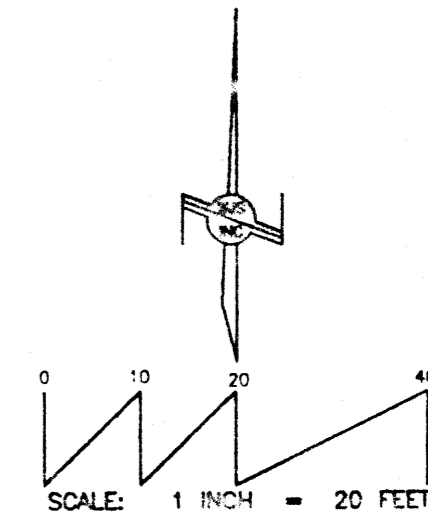

- SCALE: 1 INCH = 20 FEET
- MONUMENT LEGEND
- SET RBR SET #4 REBAR AND CAP "WAYJOHN PS 14269"
 - SET PK SET PK NAIL AND DISK "PS 14269"
 - FOUND MONUMENT AS NOTED
 - A: FOUND #4 REBAR - NO CAP
 - B: FOUND #5 REBAR - NO CAP
 - C: FOUND PK NAIL IN CONCRETE
 - D: FOUND "+" IN CONCRETE
 - E: FOUND ARROW SCRIBED IN CONCRET
 - F: FOUND SPIKE IN ASPHALT
 - G: FOUND #4 REBAR AND CAP "LS 7002"

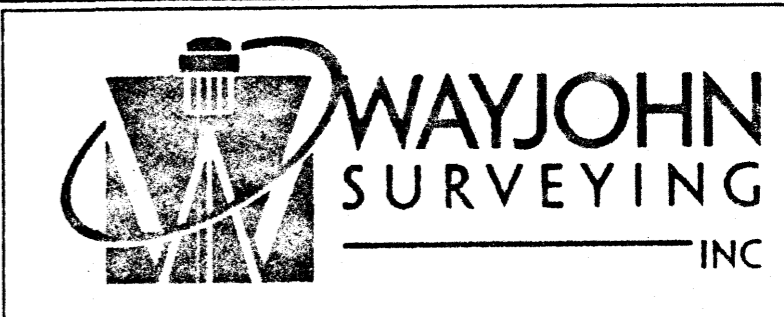
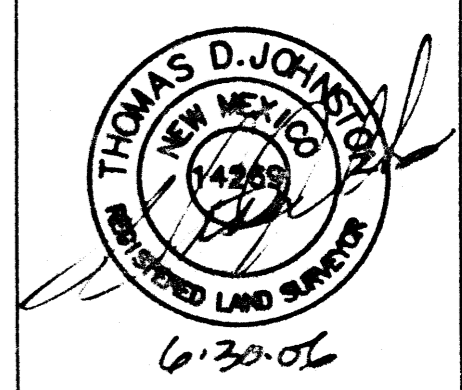

330 LOUISIANA BLVD., N.E.
 ALBUQUERQUE, N.M. 87108
 PHONE: (505) 255-2052 FAX: (505) 255-2887

DRAWN: E W K	SCALE: 1" = 20'	FILE NO. SP-6-02-2006
CHECKED: T D J		
DRAWING NO. SP80206.DWG	DATE: 27 JUNE 2006	SHEET 2 OF 2

(N 00° 14' 00" E)
 (N 00° 28' 13" E)

N 88° 56' 53" W
 (N 89° 46' 00" W)

LOT 6

BLOCK 5, ESPERANZA ADDITION
 (REC. 7/30/1946 VOLUME C, FOLIO 56)

LOT 18

270.00'
 (270.00')

(S 00° 28' 25" W)
 (S 00° 14' 00" W)

SET PK

VICINITY MAP (L-18)

NO SCALE

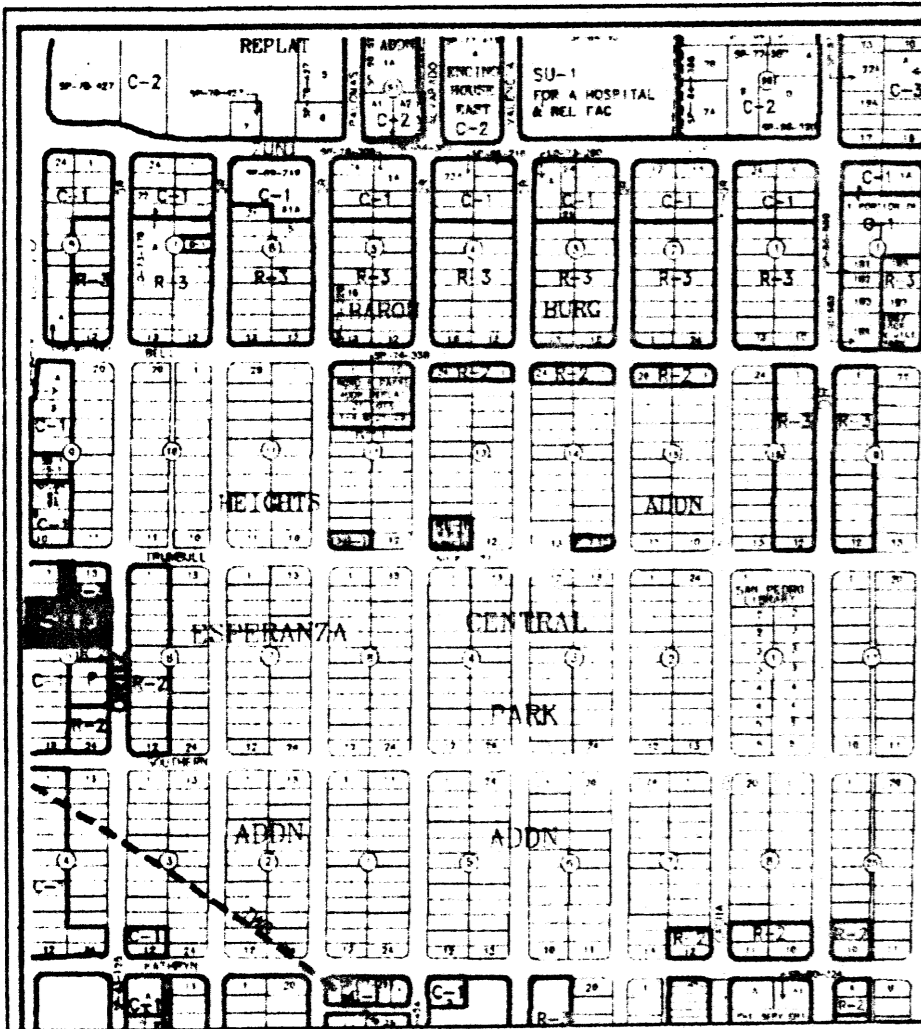

COUNTY CLERK RECORDING LABEL HERE

PLAT OF
TRACTS A-1 & A-2, BLOCK 5,
ESPERANZA ADDITION

A REPLAT OF TRACT A, BLOCK 5, ESPERANZA ADDITION
WITHIN NW 1/4, SECTION 25, T.10N., R.3E., N.M.P.M.,
ALBUQUERQUE, BERNALILLO COUNTY, NEW MEXICO

JUNE 2006

DESCRIPTION

Tract lettered "A" in Block numbered Five (5) Esperanza Addition Lands of Southwestern Construction Company, Albuquerque, New Mexico, School District number 12 as the same is shown and designated on said plat, filed in the Office of the County Clerk of Bernalillo County, New Mexico on March 5, 1959 in Plat Book A2, folio 57.

PROJECT NUMBER: 1005021

Application Number: 06DRB-01000

City Approvals:

	7/7/06
City Surveyor	Date
NA	
Environmental Health Department	Date
	8-25-06
Traffic Engineering, Transportation Division	Date
	7/26/06
Water Utility Department	Date
	7/26/06
Parks and Recreation Department	Date
	7/26/06
AMAFCA	Date
	8/29/06
City Engineer	Date
	8/29/06
DRB Chairperson, Planning Department	Date

SUBDIVISION DATA

1. DRB Proj. No. 1005021
2. Zone Atlas Index No. L-18
3. Current Zoning C-1/P
4. Gross acreage 0.9787
5. Existing number of deeded parcels 1
Replatted number of lots 2

LOG NO. 2006161754

NOTES

1. Bearings shown on this plat are New Mexico State Plane Grid, Central Zone, NAD 1927. Record distances and bearings are shown in parentheses ().
2. Perimeter distances are field measurements made on the ground and agree with deed records except as noted.
3. Monuments recovered and accepted or reset are noted on inscribed plat.
4. An existing Five foot (5') Public Utility Easement granted by the Plat of Tract A, Block 5, Esperanza Addition, recorded March 5, 1959 in Plat Book A2, folio 57.
5. An existing Ten foot (10') Public Utility Easement granted by the Plat of Tract A, Block 5, Esperanza Addition, recorded March 5, 1959 in Plat Book A2, folio 57.

PURPOSE OF PLAT

This plat has been prepared for the purposes of creating two tracts from one tract.

FREE CONSENT

The platting of the property as described above and granting of all public and private easements, is with the free consent and in accordance with the desires of the undersigned owner. Said owner warrants that he holds complete and indefeasible title in fee simple to the land subdivided.

on behalf of said Managing Member of JCP Investments, LLC a New Mexico

ACKNOWLEDGMENT

STATE OF NEW MEXICO)
COUNTY OF BERNALILLO) ss

On this 30th day of June, 2006, the foregoing instrument was acknowledged before me by J.C. Peterson a New Mexico limited liability co on behalf of said LLC.

My Commission expires 10/12/09

Notary Public

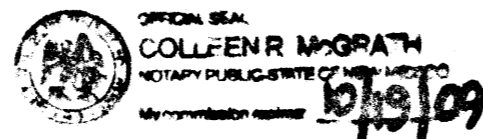

SURVEYOR'S CERTIFICATE

I, Thomas D. Johnston, licensed as a Professional Surveyor under the laws of the State of New Mexico, do hereby certify that this plat was prepared by me or under my supervision, that I am responsible for this plat, that it shows all easements of the recorded plat and made known to me by the title company, utility companies or by the owner of record, meets the minimum standards for monumentation and surveys of the Albuquerque Subdivision Ordinance, and meets the Minimum Standards for Land Surveys as adopted by the New Mexico State Board of Registration for Professional Engineers and Surveyors, effective October 1, 2000 and is true and correct to the best of my knowledge and belief.

Thomas D. Johnston, N.M.P.S. No. 14289
6-30-06
Date

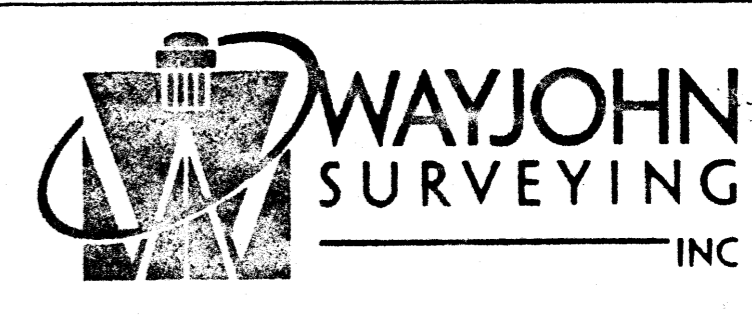
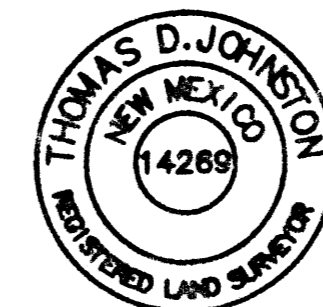

FOR BERNALILLO COUNTY TREASURER'S OFFICE USE ONLY

THIS IS TO CERTIFY THAT TAXES ARE CURRENT AND PAID ON
UPC# 100502183742006

PROPERTY OWNER OF RECORD:
Sierra Alta Partnership

BERNALILLO COUNTY TREASURER'S OFFICE
Cristobal Trujillo 8/20/06

INDEXING INFORMATION FOR COUNTY	DRAWN: E W K	SCALE: 1" = 20'	FILE NO. SP-6-02-2006
	CHECKED: T D J		
OWNER: COE PROPERTIES LOCATION: SEC. 25 T.10 N., R.3 E., N.M.P.M. ESPERANZA-ADDITION	DRAWING NO. SP60206.DWG	27 JUNE 2006	SHEET 1 OF 2

VICINITY MAP (L-18)

NO SCALE

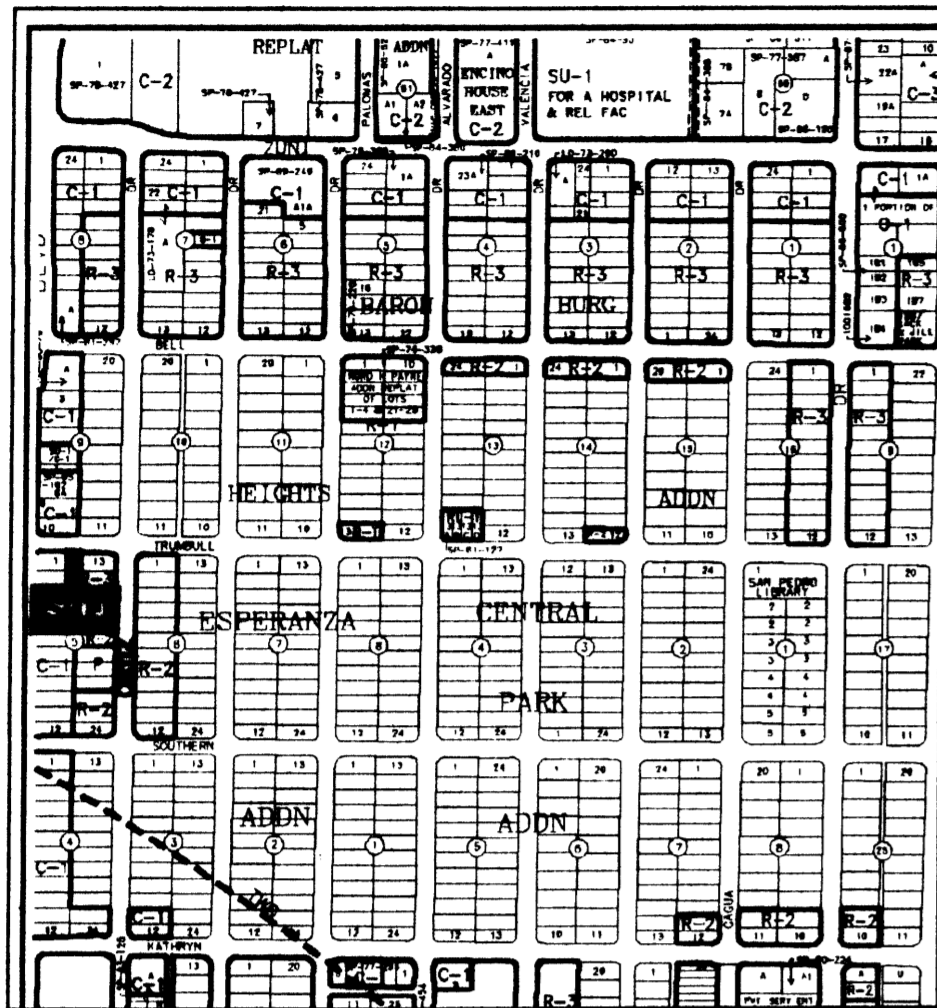

COUNTY CLERK RECORDING LABEL HERE

PLAT OF
TRACTS A-1 & A-2, BLOCK 5,
ESPERANZA ADDITION

A REPLAT OF TRACT A, BLOCK 5, ESPERANZA ADDITION
WITHIN NW 1/4, SECTION 25, T.10N., R.3E., N.M.P.M.,
ALBUQUERQUE, BERNALILLO COUNTY, NEW MEXICO

JUNE 2006
PRELIMINARY PLAT
APPROVED BY DRB
ON 7/26/06

DESCRIPTION

Tract lettered "A" in Block numbered Five (5) Esperanza Addition Lands of Southwestern Construction Company, Albuquerque, New Mexico, School District number 12 as the same is shown and designated on said plat, filed in the Office of the County Clerk of Bernalillo County, New Mexico on March 5, 1959 in Plat Book A2, folio 57.

PROJECT NUMBER: _____

Application Number: _____

City Approvals:

<i>[Signature]</i>	7/7/06
City Surveyor	Date
Environmental Health Department	Date
Traffic Engineering, Transportation Division	Date
Water Utility Department	Date
Parks and Recreation Department	Date
AMAFCFA	Date
City Engineer	Date
DRB Chairperson, Planning Department	Date

SUBMISSION DATA

1. DRB Proj. No.
2. Zone Atlas Index No. L-18
3. Current Zoning C-1/P
4. Gross acreage 0.9787
5. Existing number of deeded parcels 1
Replatted number of lots 2

LOG NO. 2006161754

NOTES

1. Bearings shown on this plat are New Mexico State Plane Grid, Central Zone, NAD 1927. Record distances and bearings are shown in parentheses ().
2. Perimeter distances are field measurements made on the ground and agree with deed records except as noted.
3. Monuments recovered and accepted or reset are noted on inscribed plat.
4. An existing Five foot (5') Public Utility Easement granted by the Plat of Tract A, Block 5, Esperanza Addition, recorded March 5, 1959 in Plat Book A2, folio 57.
5. An existing Ten foot (10') Public Utility Easement granted by the Plat of Tract A, Block 5, Esperanza Addition, recorded March 5, 1959 in Plat Book A2, folio 57.

FREE CONSENT

The platting of the property as described above and granting of all public and private easements, is with the free consent and in accordance with the desires of the undersigned owner. Said owner warrants that he holds complete and indefeasible title in fee simple to the land subdivided.

[Signature]
on behalf of said *JCP Investments, LLC*
Managing Member of JCP Investments, LLC

ACKNOWLEDGMENT

STATE OF NEW MEXICO)
COUNTY OF BERNALILLO) ss

On this 30th day of June, 2006, the foregoing instrument was acknowledged before me by *J.C. Peterson* a New Mexico *limited liability co.* on behalf of said *LLC.*

SURVEYOR'S CERTIFICATE

I, Thomas D. Johnston, licensed as a Professional Surveyor under the laws of the State of New Mexico, do hereby certify that this plat was prepared by me or under my supervision, that I am responsible for this plat, that it shows all easements of the recorded plat and made known to me by the title company, utility companies or by the owner of record, meets the minimum standards for monumentation and surveys of the Albuquerque Subdivision Ordinance, and meets the Minimum Standards for Land Surveys as adopted by the New Mexico State Board of Registration for Professional Engineers and Surveyors, effective October 1, 2000 and is true and correct to the best of my knowledge and belief.

[Signature] 6.30.06
Thomas D. Johnston, N.M.P.S. No. 14269 Date

PURPOSE OF PLAT

This plat has been prepared for the purposes of creating two tracts from one tract.

FOR BERNALILLO COUNTY TREASURER'S OFFICE USE ONLY

THIS IS TO CERTIFY THAT TAXES ARE CURRENT AND PAID ON
UPC# _____

PROPERTY OWNER OF RECORD: _____

BERNALILLO COUNTY TREASURER'S OFFICE

My Commission expires 10/19/09
[Signature]
Notary Public

OFFICIAL SEAL
COLLEEN R. McGRATH
NOTARY PUBLIC-STATE OF NEW MEXICO
My commission expires 10/19/09

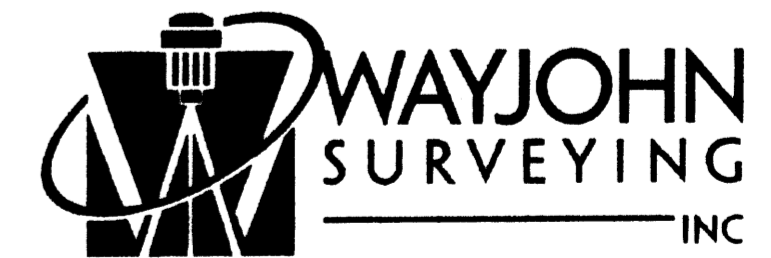
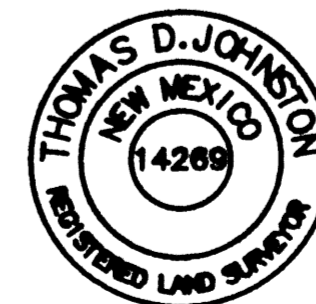

330 LOUISIANA BLVD., N.E.
ALBUQUERQUE, N.M. 87108
PHONE: (505) 255-2052 FAX: (505) 255-2887

INDEXING INFORMATION FOR COUNTY	DRAWN: E W K	SCALE: 1" = 20'	FILE NO. SP-6-02-2006
OWNER: COE PROPERTIES LOCATION: SEC. 25 T.10 N., R.3 E., N.M.P.M. ESPERANZA ADDITION	CHECKED: T D J	DRAWING NO. SP60206.DWG	SHEET 1 OF 2

TRUMBULL AVENUE, S.E.
(60' R.O.W.)

PLAT OF
**TRACTS A-1 & A-2, BLOCK 5,
ESPERANZA ADDITION**

A REPLAT OF TRACT A, BLOCK 5, ESPERANZA ADDITION
WITHIN NW 1/4, SECTION 25, T.10N., R.3E., N.M.P.M.,
ALBUQUERQUE, BERNALILLO COUNTY, NEW MEXICO

JUNE 2006

EXISTING CONDITIONS

ACS MONUMENT "6-K18A"
x = 398,545.00
y = 1,483,892.49
Ground-to-grid:
0.99966021
Delta Alpha:
-00°11'42"
NMSP CENTRAL
ZONE, NAD 1927

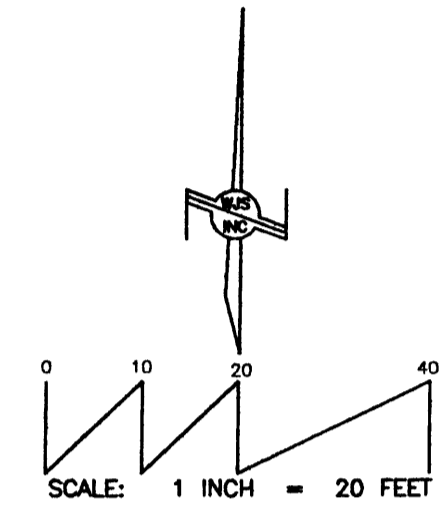

MONUMENT LEGEND

- SET RBR SET #4 REBAR AND CAP "WAYJOHN PS 14269"
- SET PK SET PK NAIL AND DISK "PS 14269"
- FOUND MONUMENT AS NOTED
- A: FOUND #4 REBAR - NO CAP
- B: FOUND #5 REBAR - NO CAP
- C: FOUND PK NAIL IN CONCRETE
- D: FOUND "+" IN CONCRETE
- E: FOUND ARROW SCRIBED IN CONCRET
- F: FOUND SPIKE IN ASPHALT
- G: FOUND #4 REBAR AND CAP "LS 7002"

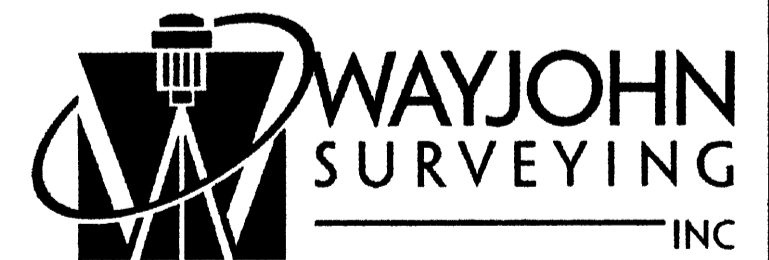

330 LOUISIANA BLVD., N.E.
ALBUQUERQUE, N.M. 87108
PHONE: (505) 255-2052 FAX: (505) 255-2887

DRAWN: E W K	SCALE: 1" = 20'	FILE NO. SP-6-02-2006
CHECKED: T D J		
DRAWING NO. SP60206.DWG	27 JUNE 2006	SHEET 2 OF 2

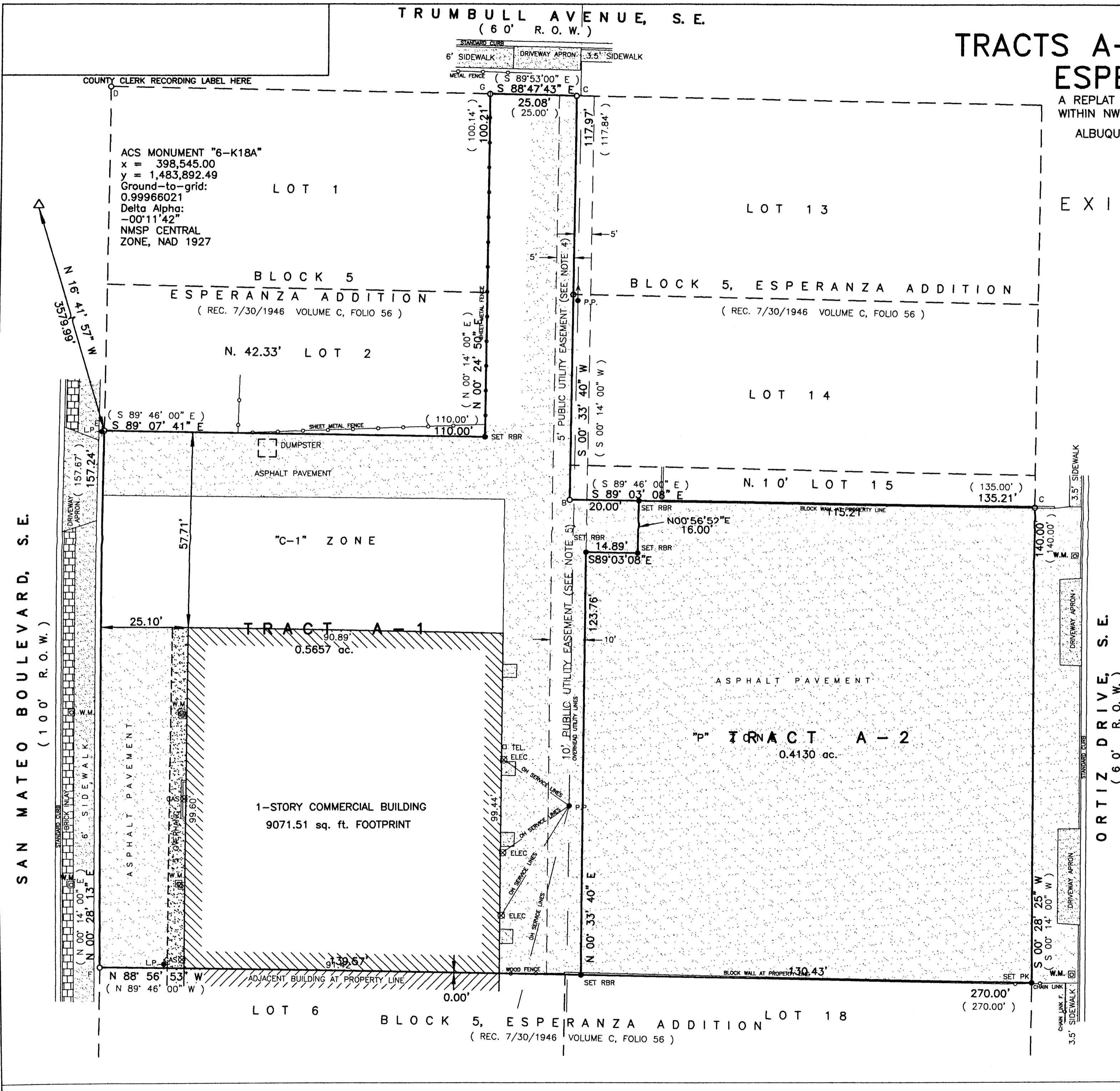

SAN MATEO BOULEVARD, S.E.
(100' R.O.W.)

ORTIZ DRIVE, S.E.
(60' R.O.W.)

COUNTY CLERK RECORDING LABEL HERE

ADJACENT BUILDING AT PROPERTY LINE

1-STORY COMMERCIAL BUILDING
9071.51 sq. ft. FOOTPRINT

"C-1" ZONE

"P" TRACT A-2
0.4130 ac.

BLOCK 5
ESPERANZA ADDITION
(REC. 7/30/1946 VOLUME C, FOLIO 56)

BLOCK 5, ESPERANZA ADDITION
(REC. 7/30/1946 VOLUME C, FOLIO 56)

LOT 6 BLOCK 5, ESPERANZA ADDITION LOT 18
(REC. 7/30/1946 VOLUME C, FOLIO 56)