

SANDIA SUNSET
 WEST OF ROCKY TOP DR. AND
 PORTIONS OF STREETS FRONTING
 ON TRACT K.

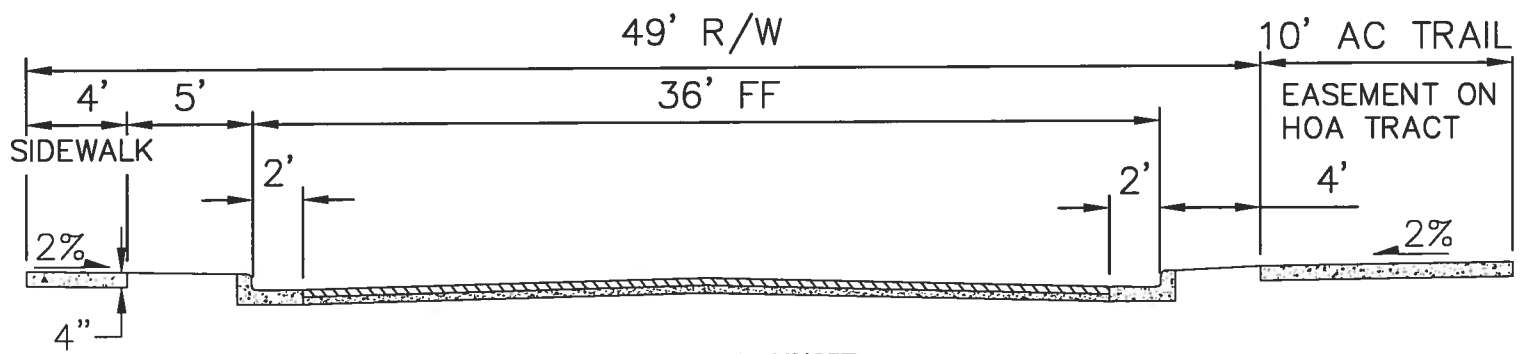

SANDIA SUNSET
 EAST OF ROCKY TOP DR.

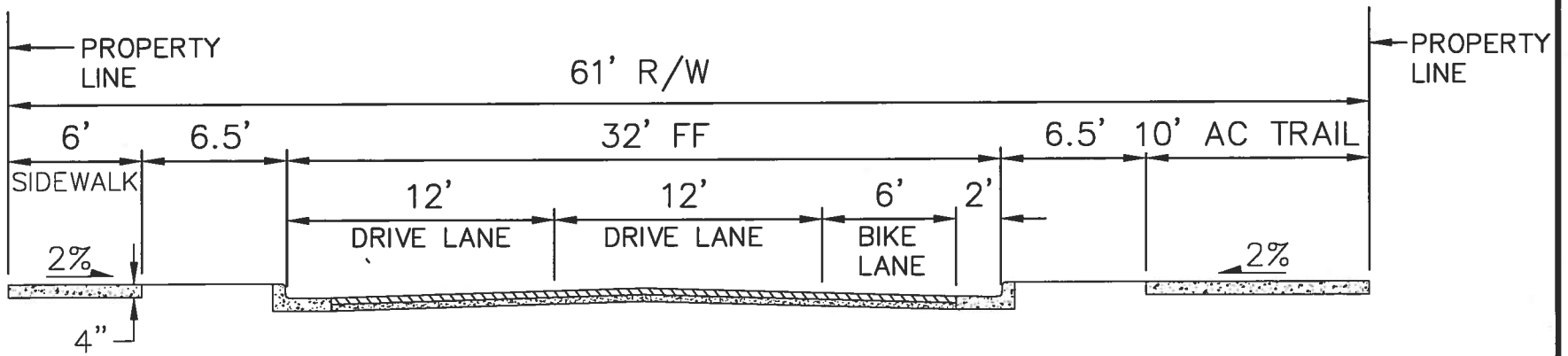

ROCKY TOP DR.

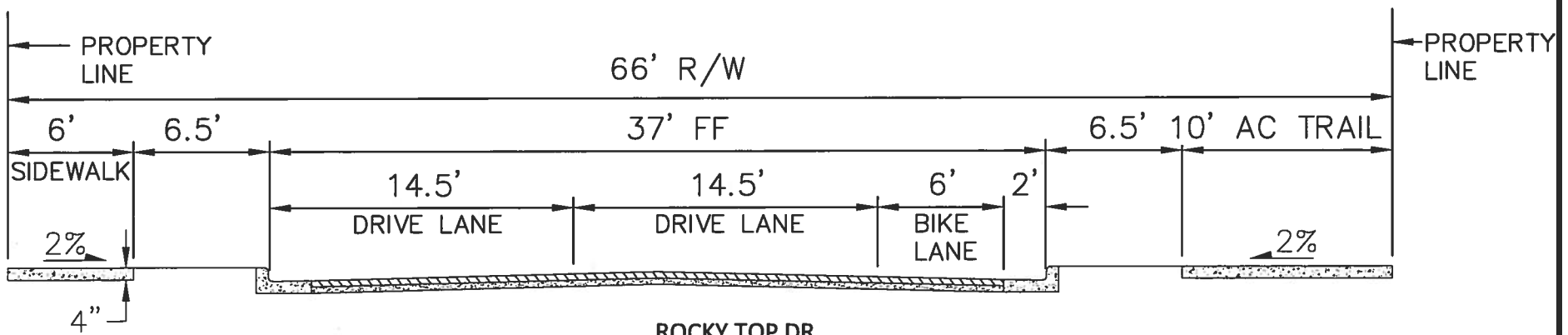

ROCKY TOP DR.
 AT JUAN TABO DR.

**CURB & SIDEWALK
 DIMENSIONS EXHIBIT**



MARK GOODWIN & ASSOCIATES, P.A.
 CONSULTING ENGINEERS
 P.O. BOX 90606
 ALBUQUERQUE, NEW MEXICO 87199
 (505)828-2200, FAX (505)797-9539

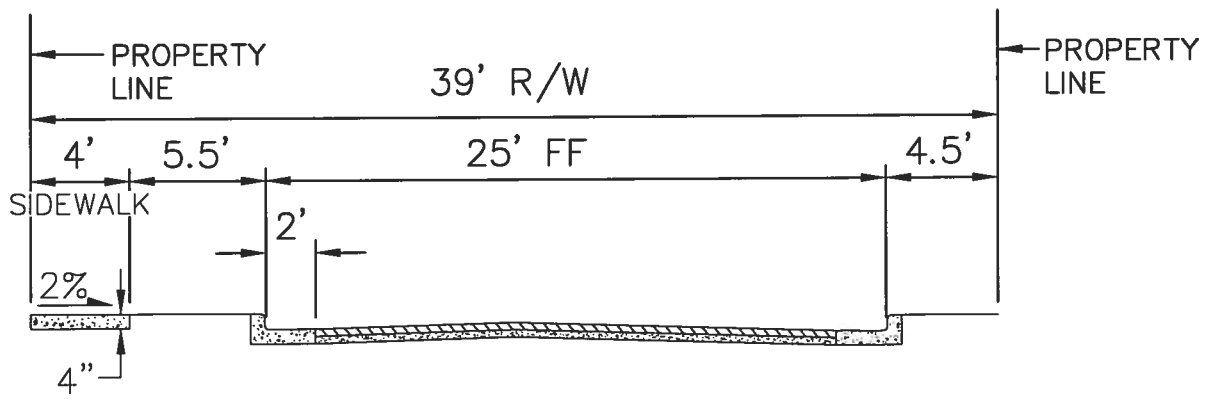

STREETS WITH WAIVED SIDEWALK

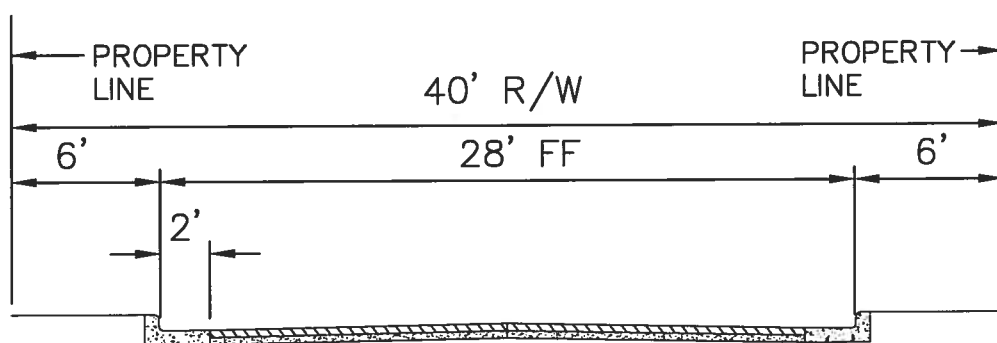

HAMMER HEAD STREETS

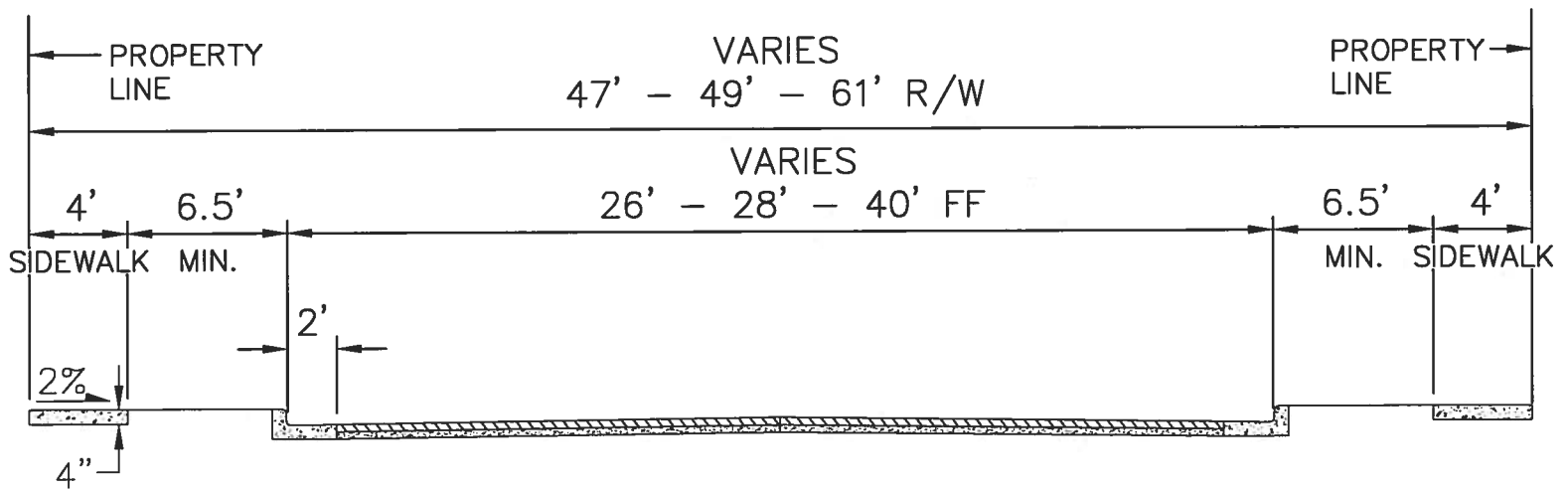

TYPICAL FOR ALL STREETS EXCEPT
ROCKY TOP DR., SANDIA SUNSET
AVE. AND THE PORTION OF
STREETS FRONTING ON TRACT K.

***CURB & SIDEWALK
DIMENSIONS EXHIBIT***



MARK GOODWIN & ASSOCIATES, P.A.
CONSULTING ENGINEERS

P.O. BOX 90606
ALBUQUERQUE, NEW MEXICO 87199
(505)828-2200, FAX (505)797-9539