

LEGAL DESCRIPTION

Tract of land situate within Sections 33 and 34, Township 10 North, Range 4 East, New Mexico Principal Meridian, City of Albuquerque, Bernalillo County, New Mexico being all of TRACT A, JUAN TABO HILLS WEST, as the same is shown and designated on said plat filed for record in the office of the County Clerk of Bernalillo County, New Mexico on June 14, 2007 in Book 2007C, Page 161 and TRACT 1-A-1, JUAN TABO HILLS, UNIT 2, as the same is shown and designated on said plat filed for record in the office of County Clerk of Bernalillo County, New Mexico on February 20, 2008 in Book 2008C, Page 30 and contains 98.4699 acres more or less.

EASEMENTS

- (A) EXISTING 30 FOOT SANITARY SEWER EASEMENT FOR THE CITY OF ALBUQUERQUE, FILED MARCH 22, 1979 IN MISC. 677 IN PAGES 777-780 AND FEBRUARY 14, 1979 IN BOOK MISC. 676 IN BOOK 46-49 AND THE TEMPORARY 10' EASEMENT IS FOR CONSTRUCTION. TO BE VACATED
- (B) EXISTING 100' DRAINAGE EASEMENT FILED AUGUST 8, 2006, IN BK A122, PAGE 9354. TO BE VACATED
- (C) EXIST. 20' WATERLINE EASEMENT FILED DECEMBER 12, 2005 IN BOOK 2005C, PAGE 406.
- (D) EXIST. 20' SANITARY SEWER EASEMENT FILED DECEMBER 12, 2005 IN BOOK 2005C, PAGE 406. A PORTION TO BE VACATED
- (E) EXISTING 50' PRIVATE ACCESS EASEMENT JUNE 14, 2007, BOOK 2007C PAGE 161. TO BE VACATED
- (F) AN EXISTING BLANKET DRAINAGE EASEMENT ON TRACT 1-A-1 FILED JANUARY 19, 2005 IN BOOK 2005C, PAGE 22.
- (G) EXISTING 150' PUBLIC SERVICE COMPANY OF NEW MEXICO EASEMENT (10-04-57, BK. D401, PG. 235)
- (H) EXISTING PUBLIC SERVICE COMPANY OF NEW MEXICO EASEMENT (12-22-2005, BK-2005C, PG-406)
- (I) EXISTING 10' P.U.E. (02/20/2008, BK-2008C, PG-30)
- (J) EXISTING 30' C.O.A. PERMANENT UTILITY & DRAINAGE EASEMENT (01-26-78, BK. 583, PGS. 804-806)
- (K) EXISTING 10' C.O.A. TEMPORARY UTILITY & DRAINAGE EASEMENT (01-26-78, BK. 583, PGS. 804-806)
- (L) EXISTING 15'x40' PNM EASEMENT (02/20/2008, BK-2008C, PG-30)
- (M) EXISTING BLANKET DRAINAGE EASEMENT GRANTED TO BERNALILLO ON TRACTS B-1 & B-2 JUAN TABO HILLS WEST.

VICINITY MAP (NTS) ZONE ATLAS MAP M-21

SUBDIVISION DATA

GROSS ACRES 98.4699 Ac.
 ZONE ATLAS NO. M-21-Z
 NO. OF LOTS CREATED 35 LOTS
 NO. OF TRACTS CREATED 15 TRACTS
 RIGHT-OF-WAY AREA DEDICATED TO CITY 18.2552 Ac
 DATE OF SURVEY DECEMBER, 2003

PURPOSE OF PLAT

- SUBDIVIDE TRACT "A" JUAN TABO HILLS WEST INTO 359 RESIDENTIAL LOTS AND 18 TRACTS AND TO SUBDIVIDE TRACT "1-A-1" JUAN TABO HILLS, UNIT 2 INTO TWO TRACTS.
- DEDICATE RIGHT-OF-WAY AS SHOWN.
- GRANT NEW EASEMENTS AS SHOWN.
- VACATE EASEMENTS AS SHOWN.

NOTES

- UNLESS OTHERWISE NOTED, ALL BOUNDARY CORNERS SHOWN THUS SHALL BE MARKED BY A #5 REBAR W/CAP STAMPED PSH#7192.
- ALL STREET CENTERLINE MONUMENTATION SHALL BE INSTALLED AT ALL CENTERLINE PCS, PTS, ANGLE POINTS, AND STREET INTERSECTIONS AND SHOWN THUS ▲, WILL BE MARKED BY A FOUR INCH (4") ALUMINUM CAP STAMPED: "CITY OF ALBUQUERQUE CENTERLINE MONUMENTATION" "DO NOT DISTURB" "PSH#719"
- BOUNDARY SHALL BE TIED TO THE NEW MEXICO STATE PLANE COORDINATE SYSTEM AS SHOWN.
- BASIS OF BEARING SHALL BE NEW MEXICO STATE PLANE GRID BEARINGS.
- ALL DISTANCES SHALL BE GROUND DISTANCES
- MANHOLES WILL BE OFFSET AT ALL POINTS OF CURVATURE, POINTS OF TANGENCY, STREET INTERSECTIONS, AND ALL OTHER ANGLE POINTS TO ALLOW USE OF CENTERLINE MONUMENTATION.

APPROVED

JUAN TABO HILLS WEST LLC OWNER "TRACT A JUAN TABO HILLS WEST"
 DATE 10/8/15
 ITS MEMBER SANDIA EAST TECHNOLOGY PARK, LLC
 REX F. WILSON, MANAGING MEMBER
 DATE 10/8-15
 ITS MEMBER GRIP HOLDINGS, LLC
 SCOTT GRADY, MANAGING MEMBER
 CITY OF ALBUQUERQUE OWNER TRACT 1-A-1, JUAN TABO HILLS, UNIT 2
 ROBERT J. PERRY, CHIEF ADMINISTRATIVE OFFICER
 DATE 10/9/15
 SAUL M. RIMMERS P.S.
 CITY SURVEYOR, CITY OF ALBUQUERQUE, N.M.
 DATE 10/8/15

ENGINEERS

D. MARK GOODWIN & ASSOCIATES, P.A.
 CONSULTING ENGINEERS
 P.O. BOX 90606
 ALBUQUERQUE, NEW MEXICO 87199
 (505) 828-2200

SURVEYOR

ALDRICH LAND SURVEY
 P.O. BOX 30701
 ALBUQUERQUE, N.M. 87190-0701
 (505) 884-1990

OWNERS

JUAN TABO HILLS WEST LLC
 P.O. BOX 9470
 ALBUQUERQUE, NEW MEXICO 87179
 (505) 899-6768

SITE BENCHMARK

AGRS MONUMENT
 "5-M22"
 ELEVATION=5594.518
 (NAVD 1929)

CURVE TABLE						
CURVE#	RADIUS	LENGTH	DELTA	TANGENT	CHORD BEARING	CHORD DISTANCE
C1	1647.00'	1241.69'	43°11'45"	652.02'	N34°31'12"E	1212.49'
C2	1628.00'	290.15'	10°12'41"	145.46'	N51°00'43"E	289.76'
C3	8872.00'	1330.26'	8°35'27"	666.38'	N50°12'06"E	1329.01'
C4	1772.00'	268.65'	8°41'11"	134.58'	N58°50'26"E	268.38'
C5	1128.00'	478.38'	24°17'57"	242.84'	S51°02'03"W	474.80'
C6	690.00'	374.54'	31°06'02"	192.01'	S43°52'25"W	369.95'
C7	686.00'	771.51'	64°26'17"	432.32'	S02°46'51"E	731.49'
C8	450.00'	242.23'	30°50'29"	124.13'	N73°09'19"E	239.31'
C9	550.00'	239.72'	24°58'22"	121.79'	N70°13'15"E	237.82'
C10	1050.00'	9.52'	0°31'09"	4.76'	N82°58'00"E	9.51'
C11	30.00'	50.82'	9°03'26"	33.94'	S48°14'42"E	44.95'
C12	950.00'	30.14'	1°49'05"	15.07'	S83°36'58"W	30.14'
C13	450.00'	196.13'	24°58'22"	99.65'	S70°13'15"W	194.58'
C14	550.00'	296.06'	30°50'29"	151.71'	S73°09'18"W	292.49'

Line Table		
Line #	Bearing	DISTANCE
L1	S74°16'53"E	142.42'
L2	S28°19'24"W	198.88'
L4	S35°00'00"E	159.38'
L5	S55°00'00"W	276.00'
L6	S60°26'38"W	81.23'
L7	S83°19'19"W	258.71'
L8	S0°00'00"E	276.99'
L9	S21°42'32"W	337.11'
L10	S0°17'01"W	374.51'
L11	N88°34'33"E	402.72'
L12	N82°42'26"E	145.51'
L13	S0°17'01"W	67.07'
L14	S82°42'26"W	145.51'
L15	S0°17'01"W	99.76'
L16	N89°19'34"W	50.00'

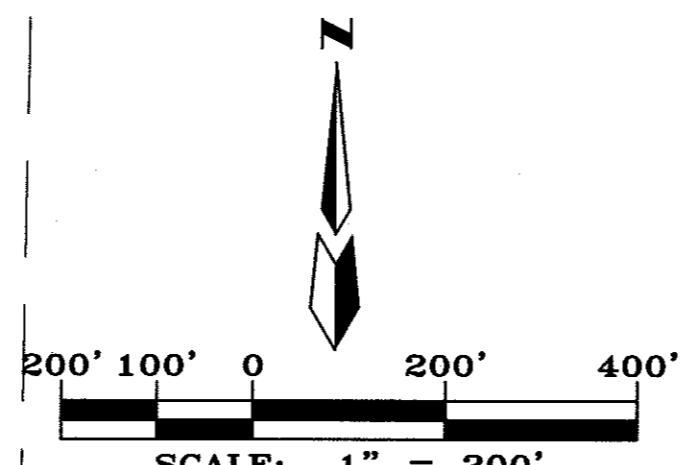

PRELIMINARY PLAT FOR
JUAN TABO HILLS WEST ESTATES
 WITHIN
 SECTION 33
 TOWNSHIP 10 NORTH, RANGE 4 EAST, NMPM
 CITY OF ALBUQUERQUE
 BERNALILLO COUNTY, NEW MEXICO
 SEPTEMBER, 2015

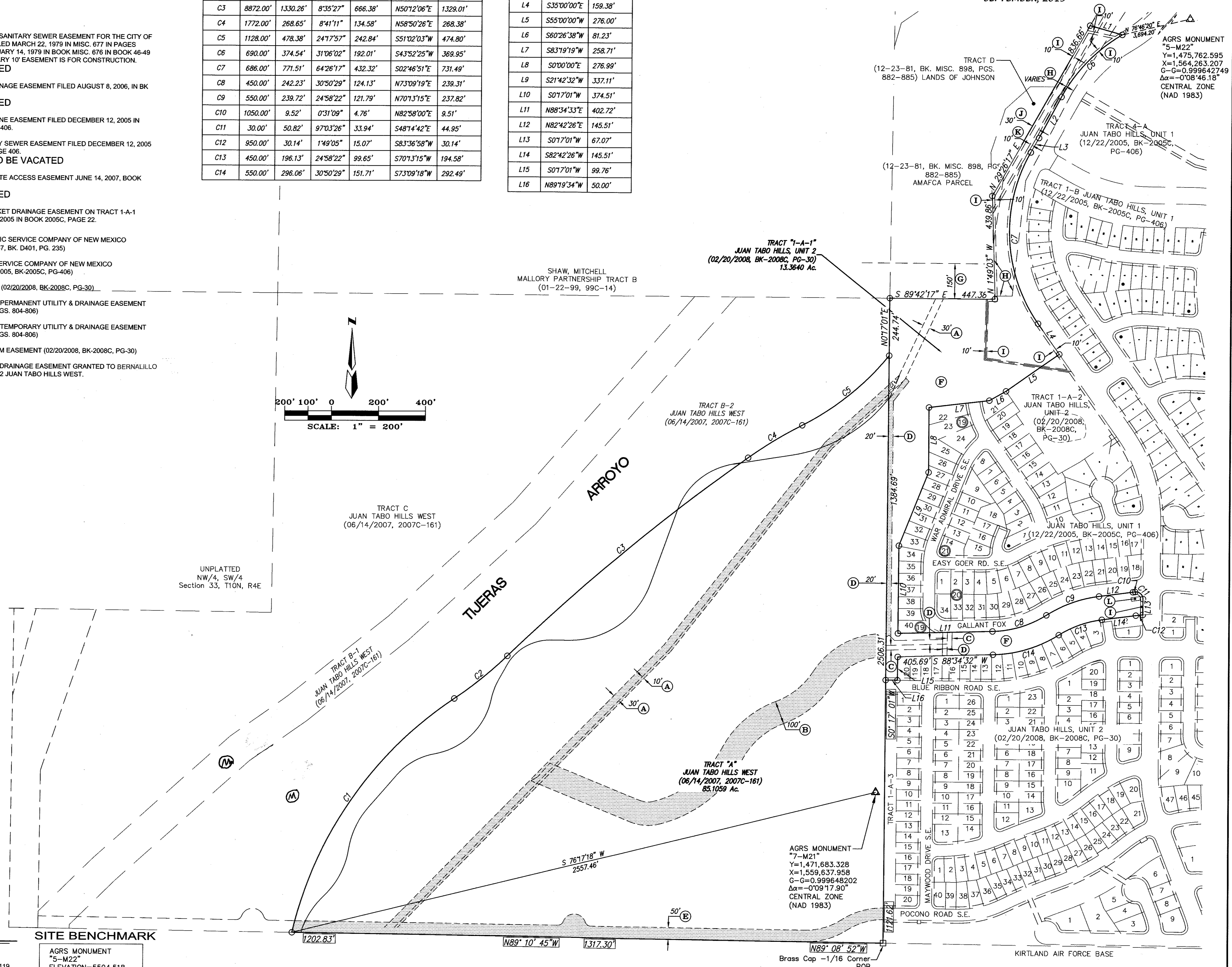

AGRS MONUMENT
 "5-M22"
 Y=1,475,762.595
 X=1,564,263.207
 G-G=0.999642749
 Δα=-0°08'46.18"
 CENTRAL ZONE
 (NAD 1983)

AGRS MONUMENT
 "7-M21"
 Y=1,471,683.328
 X=1,559,637.958
 G-G=0.999648202
 Δα=-0°09'17.90"
 CENTRAL ZONE
 (NAD 1983)

PRELIMINARY PLAT FOR
JUAN TABO HILLS ESTATES
 WITHIN
 SECTION 33
 TOWNSHIP 10 NORTH, RANGE 4 EAST, NMPM
 CITY OF ALBUQUERQUE
 BERNALILLO COUNTY, NEW MEXICO
 JANUARY, 2016

- EASEMENTS**
- (C) EXIST. 20' WATERLINE EASEMENT FILED DECEMBER 12, 2005 IN BOOK 2005C, PAGE 406.
 - (D) EXIST. 20' SANITARY SEWER EASEMENT FILED DECEMBER 12, 2005 IN BOOK 2005C, PAGE 406.
 A PORTION TO BE VACATED
 - (F) AN EXISTING BLANKET DRAINAGE EASEMENT ON TRACT 1-A-1 FILED JANUARY 19, 2005 IN BOOK 2005C, PAGE 22.
 - (N) NEW 10' PUBLIC TRAIL EASMENT MAINTAINED BY THE H.O.A.
 - (O) NEW 20' WATERLINE EASEMENT GRANTED TO A.B.C.W.U.A.
 - (P) NEW 33' WATERLINE EASEMENT GRANTED TO A.B.C.W.U.A.
 - (Q) NEW 20' SAS EASEMENT GRANTED TO A.B.C.W.U.A.
 - (R) NEW 20' PUBLIC STORM DRAIN EASEMENT TO C.O.A.
 - (S) NEW 25' PUBLIC STORM DRAIN EASEMENT TO C.O.A.
 - (T) NEW 20' WATERLINE EASEMENT GRANTED TO A.B.C.W.U.A.
 - (U) NEW BLANKET DRAINAGE EASEMENT GRANTED TO AMAFCA ON TRACTS L & M.
 - (W) NEW 50' ACCESS EASEMENT GRANTED BY THIS PLAT.

UNPLATTED
 NW/4, SW/4
 Section 33, T10N, R4E

FLOOD PLAIN LEGEND

	LIMITS 100 YEAR FLOOD PLAIN
	LIMITS 500 YEAR FLOOD PLAIN
	LIMITS OF FLOODWAY
	LIMITS AO ZONE

FEMA SPECIAL FLOOD HAZARD ZONE ON THIS PROPERTY AS SHOWN ON CASE NO. 13-06-1053P EFFECTIVE JUNE 17, 2013.

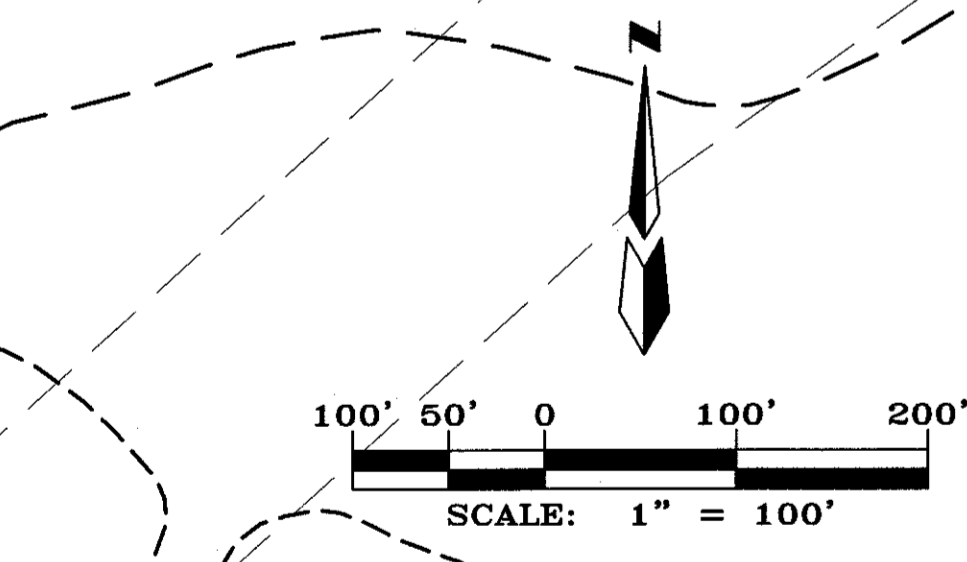

- LEGEND**
- 1 LOT NUMBER
 - (17) BLOCK NUMBER
 - ▲ CENTER LINE MONUMENT
 - ROW RIGHT-OF-WAY
 - FOUND 5/8" REBAR WITH CAP "LS 7719" (TYP)

EXISTING 50' ACCESS EASEMENT

CURVE TABLE

CURVE#	RADIUS	LENGTH	DELTA	TANGENT	CHORD BEARING	CHORD DISTANCE
C1	1647.00'	1241.69'	43°11'45"	652.02'	N34°31'12"E	1212.49'
C2	1628.00'	290.15'	101°2'41"	145.46'	N51°00'43"E	289.76'
C3	8872.00'	1330.26'	8°35'27"	666.38'	N50°12'06"E	1329.01'
C4	1772.00'	268.65'	8°41'11"	134.58'	N58°50'26"E	268.38'
C5	1128.00'	478.38'	24°7'57"	242.84'	N51°02'03"E	474.80'
C20	690.00'	374.54'	31°06'02"	192.01'	S43°52'25"W	369.95'
C21	686.00'	771.51'	64°26'17"	432.32'	S02°46'51"E	731.49'
C22	450.00'	242.23'	30°50'29"	124.13'	N73°09'19"E	239.31'
C23	550.00'	239.72'	24°58'22"	121.79'	N70°13'15"E	237.82'
C24	1050.00'	9.52'	0°31'09"	4.76'	N82°58'00"E	9.51'
C25	30.00'	50.82'	97°03'26"	33.94'	S48°14'42"E	44.95'
C26	950.00'	30.14'	1°49'05"	15.07'	S83°36'58"W	30.14'
C27	450.00'	196.13'	24°58'22"	99.65'	S70°13'15"W	194.58'
C28	550.00'	296.06'	30°50'29"	151.71'	S73°09'18"W	292.49'

PARCEL LINE TABLE

LINE	BEARING	DISTANCE
L2	S28°19'24"W	198.88'
L3	S29°26'17"W	70.61'
L4	S35°00'00"E	159.38'
L5	S55°00'00"W	276.00'
L6	S60°26'38"W	81.23'
L7	S83°19'19"W	258.71'
L8	S0°00'00"E	276.99'
L9	S21°42'32"W	337.11'
L10	S0°17'01"W	374.51'
L11	N88°34'33"E	402.72'
L12	N82°42'26"E	145.51'
L13	S0°17'01"W	67.07'
L14	S82°42'26"W	145.51'
L16	N89°19'54"W	50.00'
L20	S74°16'53"E	142.42'

- NOTES:**
- TRACTS A, B, C, D, E, F, G, H, J, K, L, M, O & P WILL BE CONVEYED TO THE JUAN TABO HILLS ESTATES H.O.A. WILL BE MAINTAINED BY THE JUAN TABO HILLS ESTATES H.O.A.
 - TRACT N WILL BE GRANTED TO THE CITY OF ALBUQUERQUE AS A DRAINAGE RIGHT OF WAY FOR A MAINTENANCE AND OPERATION OF A STORM WATER POND.
 - TRACT 1-A-1 SUBDIVIDED INTO TRACT 1-A-1-A AND TRACT 1-A-1-B TO ACCOMMODATE PROPOSED ROCKY TOP DRIVE S.E. PUBLIC RIGHT-OF-WAY ACCESS.
 - THE 10' TRAIL IN ROCKY TOP DRIVE WILL BE MAINTAINED BY THE JUAN TABO HILLS ESTATES H.O.A.
 - TRACT K IS A (PRIVATE PARK) MAINTAINED BY THE JUAN TABO HILLS ESTATES H.O.A.

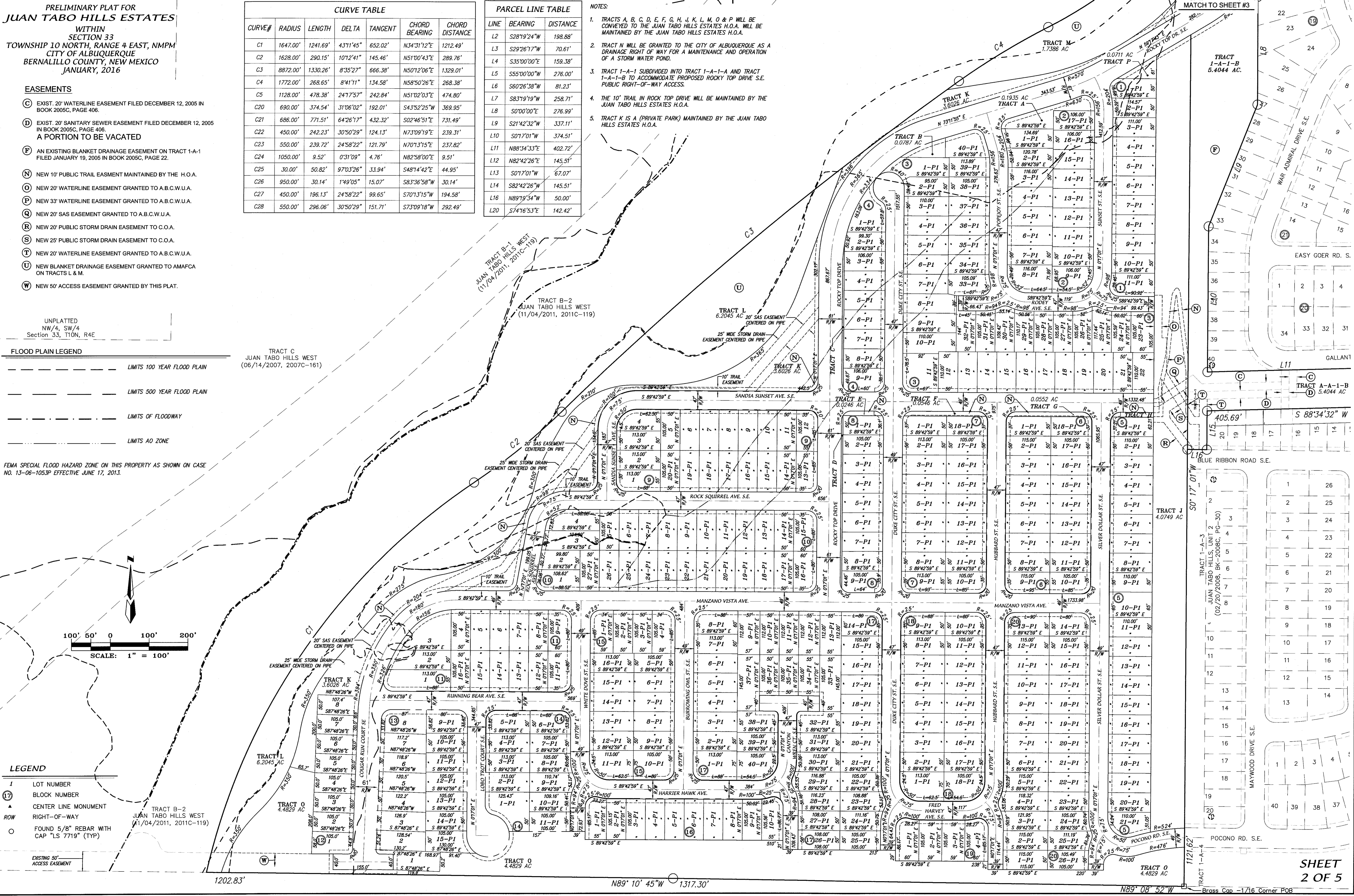

PRELIMINARY PLAT FOR
JUAN TABO HILLS ESTATES
 WITHIN
 SECTION 33
 TOWNSHIP 10 NORTH, RANGE 4 EAST, NMPM
 CITY OF ALBUQUERQUE
 BERNALILLO COUNTY, NEW MEXICO
 JANUARY, 2016

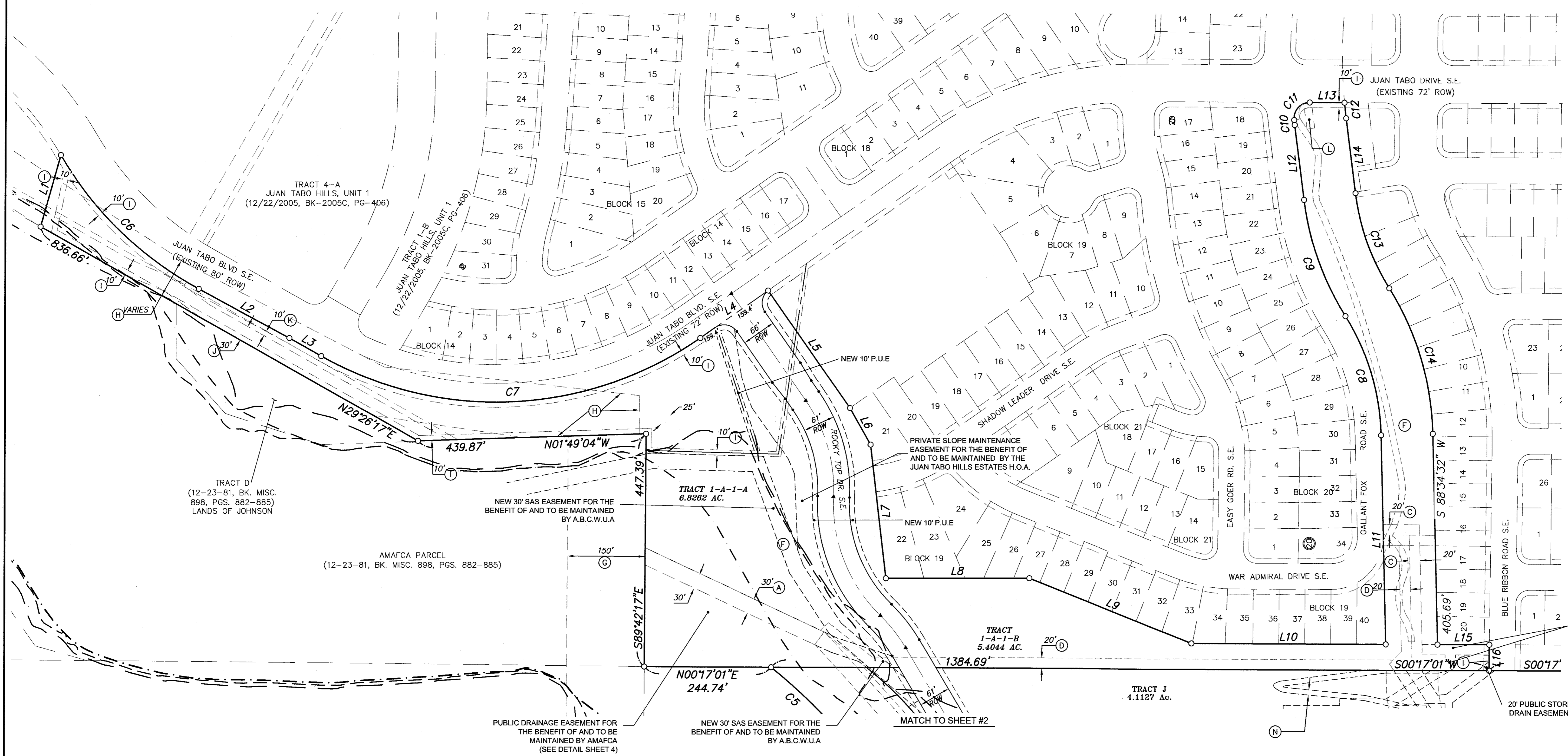

PARCEL LINE TABLE

LINE	BEARING	DISTANCE
L1	S74°16'53"E	142.42'
L2	S28°19'24"W	198.88'
L3	S29°26'17"W	70.61'
L4	S35°00'00"E	159.38'
L5	S55°00'00"W	276.00'
L6	S60°26'38"W	81.23'
L7	S83°19'19"W	258.71'
L8	S0°00'00"E	276.99'
L9	S21°42'32"W	337.11'
L10	S0°17'01"W	374.51'
L11	N88°34'33"E	402.72'
L12	N82°42'26"E	145.51'
L13	S0°17'01"W	67.07'
L14	S82°42'26"W	145.51'
L16	N89°19'34"W	50.00'

CURVE TABLE

CURVE#	RADIUS	LENGTH	DELTA	TANGENT	CHORD BEARING	CHORD DISTANCE
C2	1772.00'	268.65'	8°41'11"	134.58'	N58°50'26"E	268.38'
C3	8872.00'	1330.26'	8°35'27"	666.38'	N50°12'06"E	1329.01'
C4	1628.00'	290.15'	10°12'41"	145.46'	N51°00'43"E	289.76'
C5	1128.00'	478.38'	24°17'57"	242.84'	N51°02'03"E	474.80'
C6	690.00'	374.54'	31°06'02"	192.01'	S43°52'25"W	369.95'
C7	686.00'	771.51'	64°26'17"	432.32'	S02°46'51"E	731.49'
C8	450.00'	242.23'	30°50'29"	124.13'	N73°09'19"E	239.31'
C9	550.00'	239.72'	24°58'22"	121.79'	N70°13'15"E	237.82'
C10	1050.00'	9.52'	0°31'09"	4.76'	N82°58'00"E	9.51'
C11	30.00'	50.82'	97°03'26"	33.94'	S48°14'42"E	44.95'
C12	950.00'	30.14'	1°49'05"	15.07'	S83°36'58"W	30.14'
C13	450.00'	196.13'	24°58'22"	99.65'	S70°13'15"W	194.58'
C14	550.00'	296.06'	30°50'29"	151.71'	S73°09'18"W	292.49'

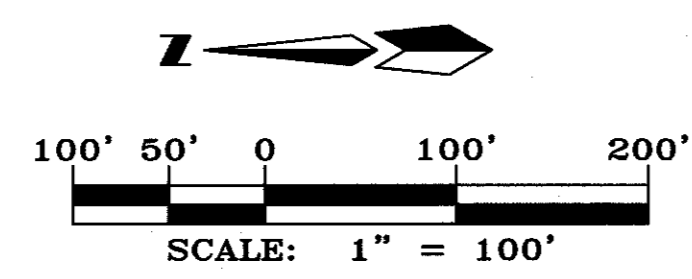

PROPERTY CORNERS
 ○ FOUND 5/8" REBAR WITH CAP "LS 7719" (TYP)
LEGEND
 I LOT NUMBER
 (17) BLOCK NUMBER
 ▲ CENTER LINE MONUMENT
 ROW RIGHT-OF-WAY

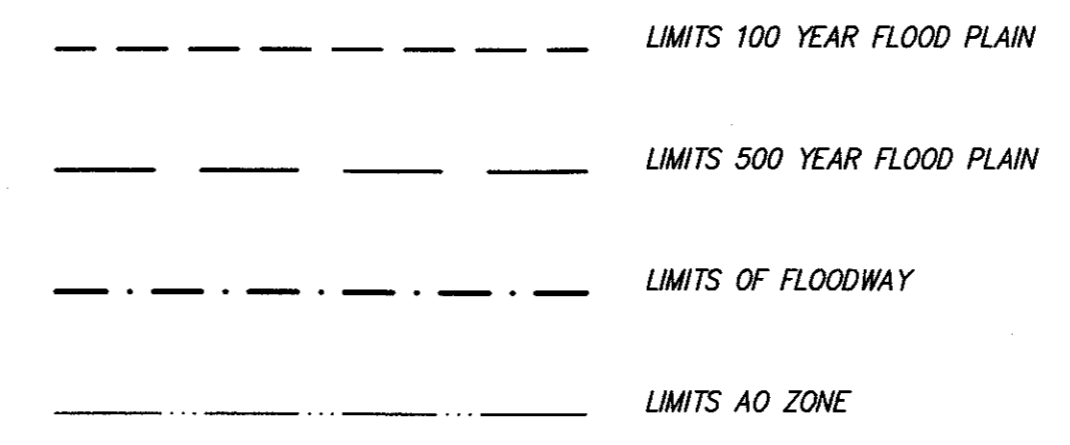

PRELIMINARY PLAT FOR
JUAN TABO HILLS ESTATES
 WITHIN
 SECTION 33
 TOWNSHIP 10 NORTH, RANGE 4 EAST, NMPM
 CITY OF ALBUQUERQUE
 BERNALILLO COUNTY, NEW MEXICO
 JANUARY, 2016

AMAFCA PARCEL
 (12-23-81, BK. MISC. 898,
 PGS. 882-885)

AMAFCA PARCEL
 (12-23-81, BK. MISC.
 898, PGS. 882-885)

TRACT 1-A-2
 JUAN TABO HILLS,
 UNIT 2
 (02/20/2008,
 BK-2008C, PG-30)

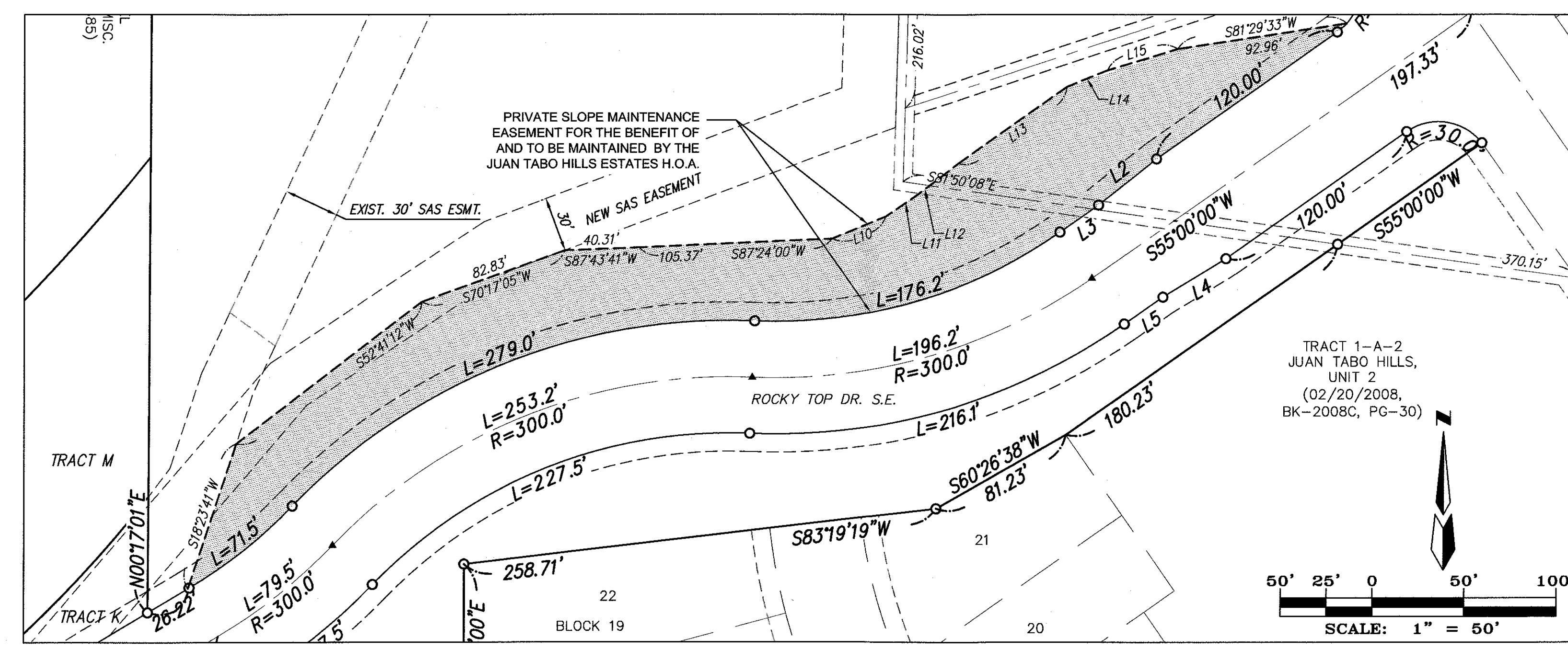
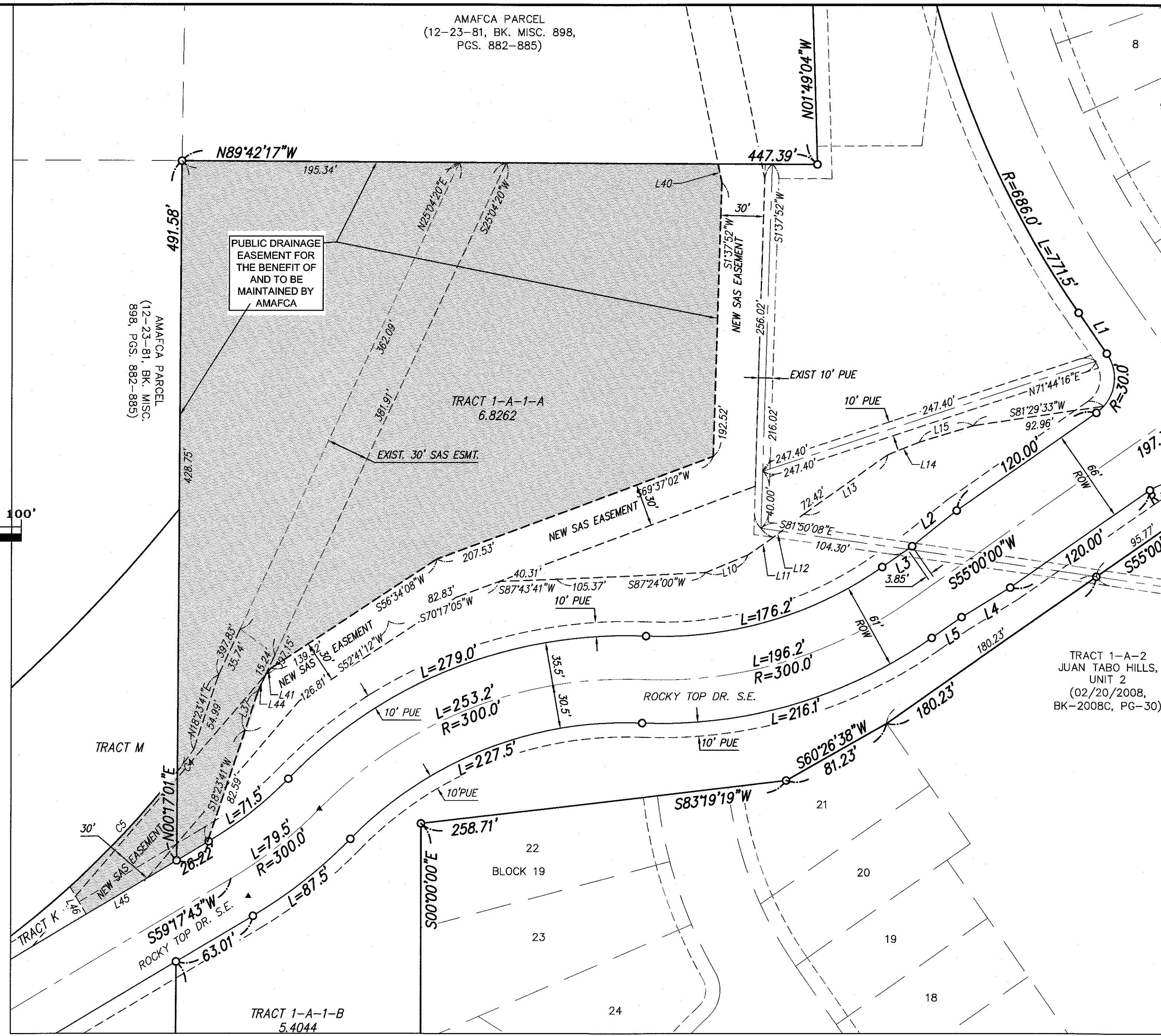
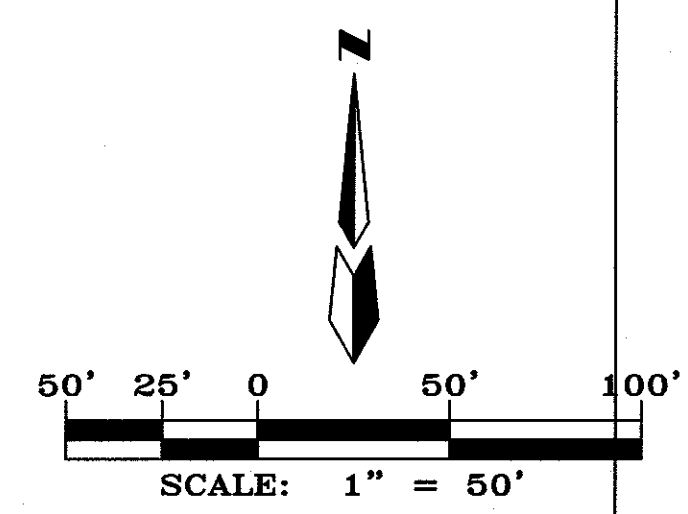

- PROPERTY CORNERS**
- FOUND 5/8" REBAR WITH CAP "LS 7719" (TYP)
- LEGEND**
- 1 LOT NUMBER
 - ① BLOCK NUMBER
 - ▲ CENTER LINE MONUMENT
 - ROW RIGHT-OF-WAY

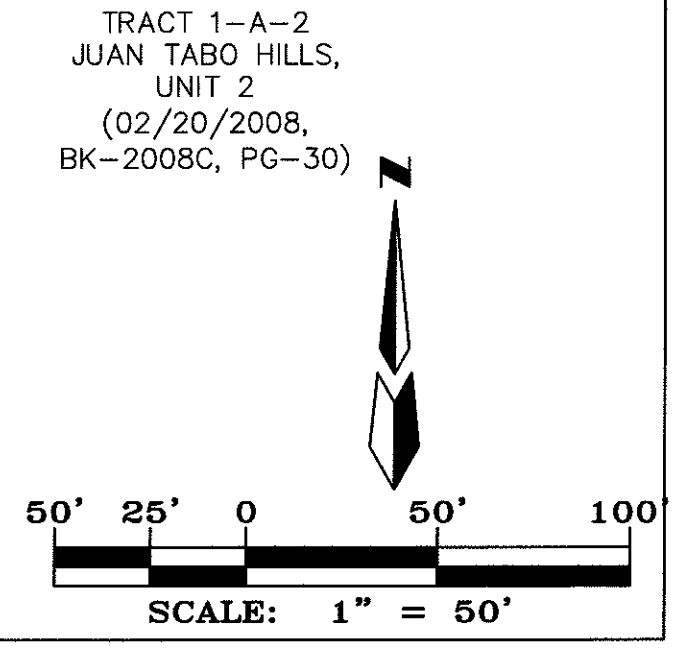

PRELIMINARY PLAT FOR
JUAN TABO HILLS ESTATES
 WITHIN
 SECTION 33
 TOWNSHIP 10 NORTH, RANGE 4 EAST, NMPM
 CITY OF ALBUQUERQUE
 BERNALILLO COUNTY, NEW MEXICO
 JANUARY, 2016

Line #	Direction	Length
L24	N89°42'59"W	7.00'
L25	N89°42'59"W	13.00'
L26	S89°35'26"E	26.26'
L27	S0°17'01"W	30.01'
L29	N0°17'01"E	65.07'
L30	N89°42'59"W	23.46'
L32	N89°42'59"W	13.00'
L33	N89°42'59"W	20.00'
L34	N89°42'59"W	20.00'
L36	N6°04'06"W	17.25'
L89	N7°55'02"E	23.12'
L91	S3°58'13"E	37.67'
L92	S0°24'34"W	33.79'
L93	N0°24'34"E	23.40'
L94	N89°35'26"E	24.25'
L95	S89°35'26"E	14.27'
L96	N3°58'13"W	38.74'

Curve #	Length	Radius	Delta	Chord B.	Chord L.
C51	20.24'	64.56'	17°57'40"	S14°08'57"E	20.15'
C52	13.76'	37.30'	21°07'51"	N19°09'39"W	13.68'
C53	9.70'	5.00'	111°06'52"	N85°17'00"W	8.25'
C54	16.66'	56.50'	16°53'45"	S30°42'41"W	16.60'
C55	2.88'	1.00'	164°54'51"	N89°37'32"W	1.98'

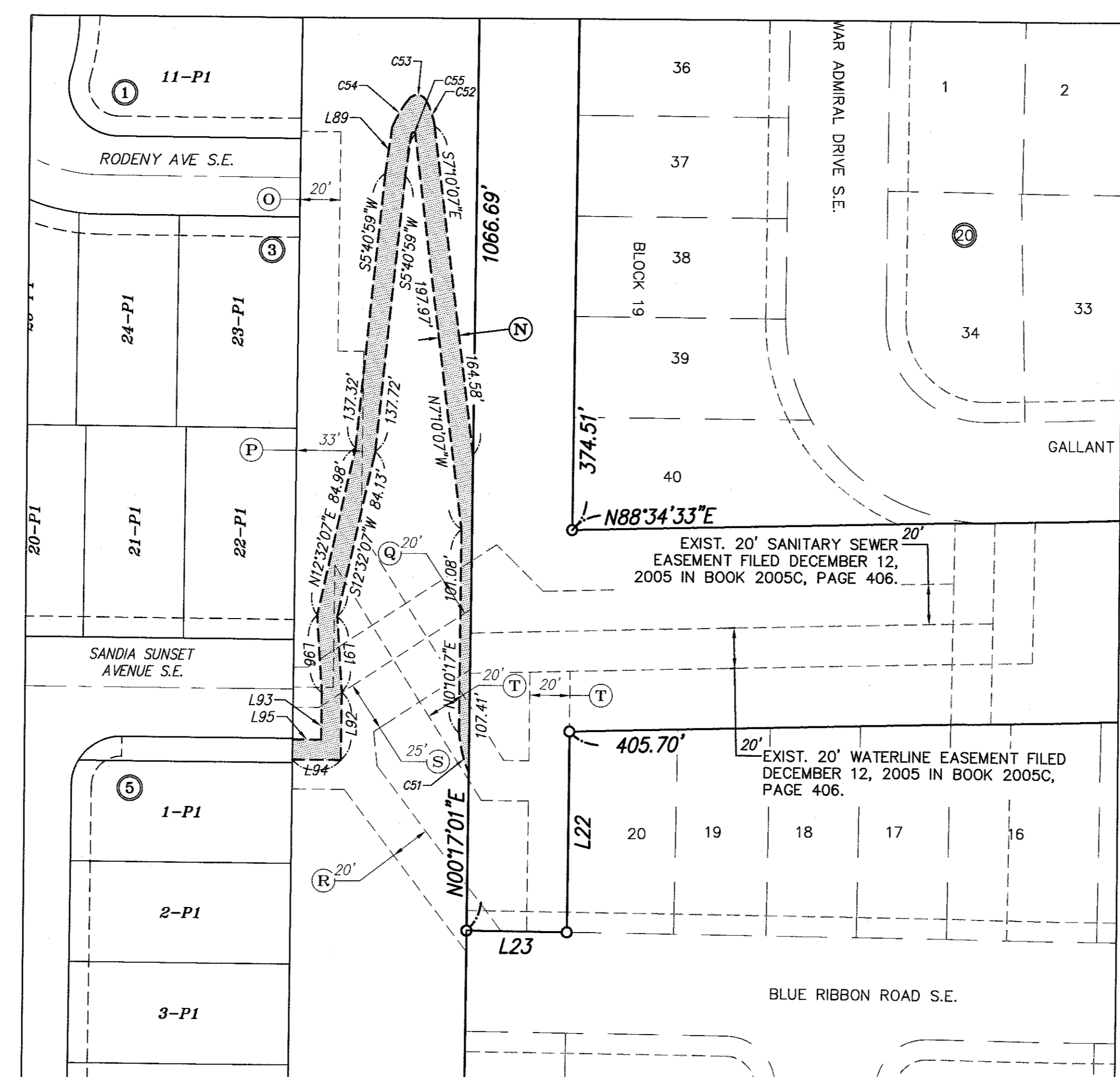
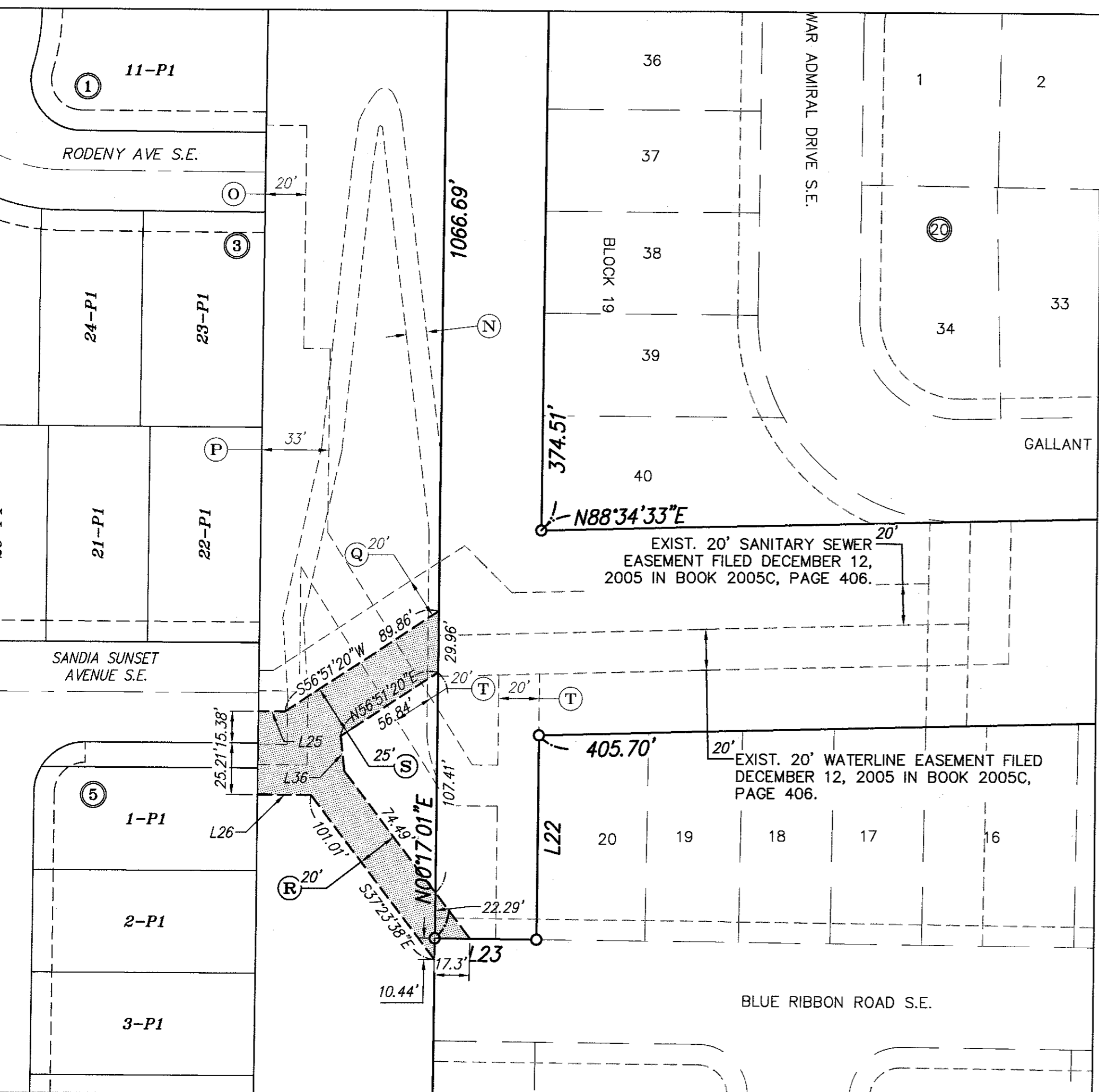
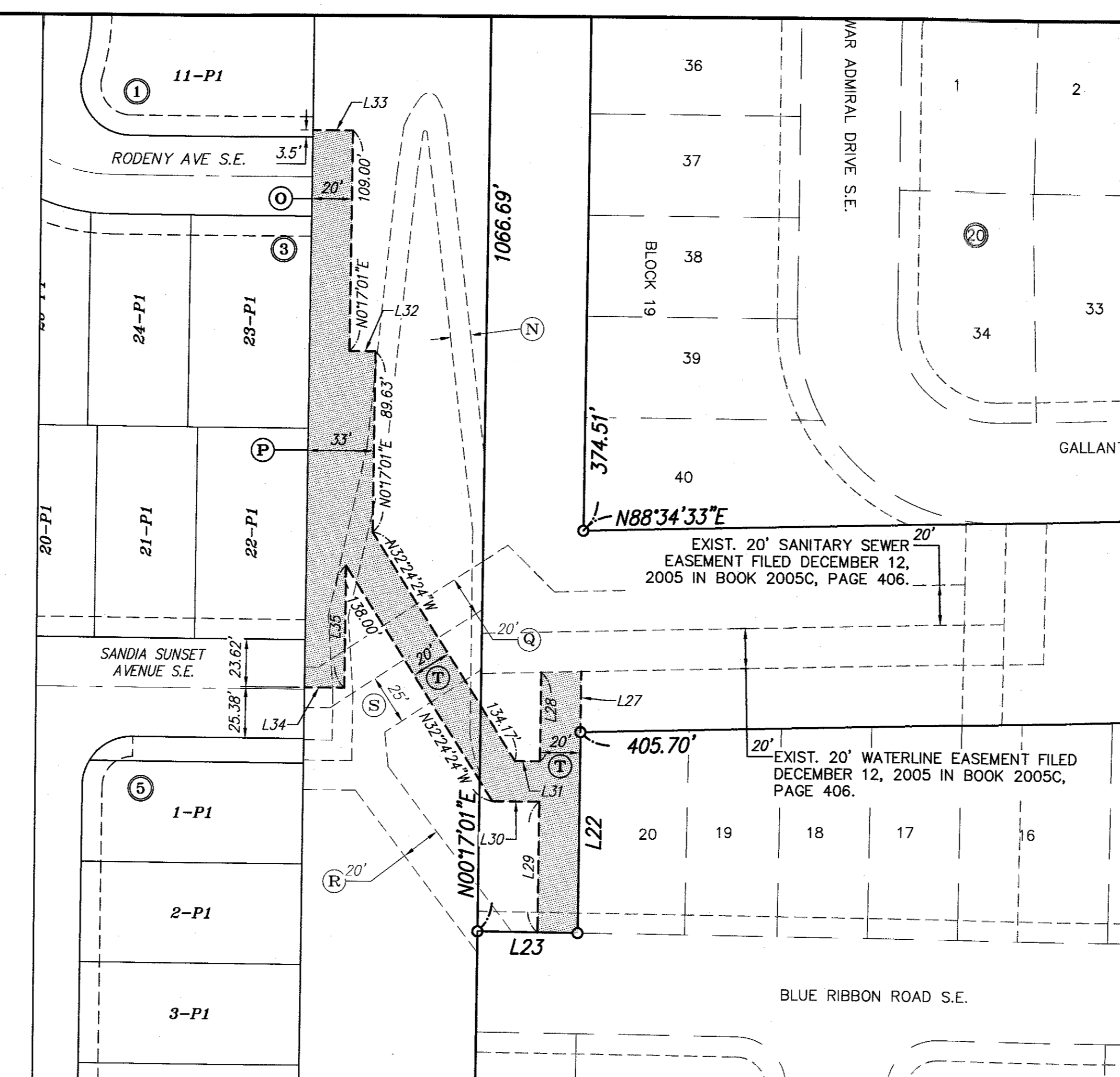
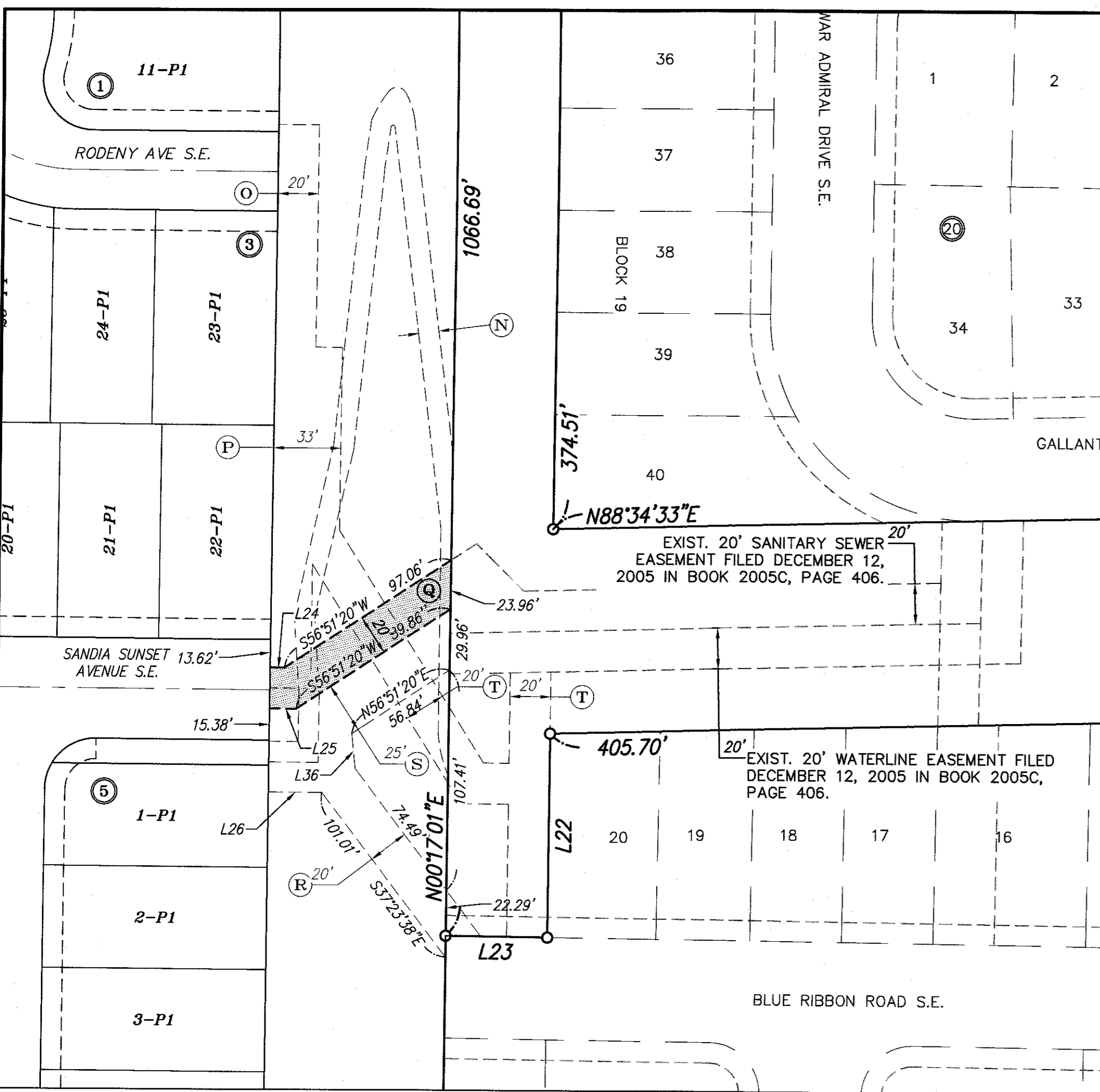

- (N) NEW 10' PUBLIC TRAIL EASMENT TO BE MAINTAINED BY H.O.A.
- (O) NEW 20' WATERLINE EASEMENT GRANTED TO A.B.C.W.U.A.
- (P) NEW 33' WATERLINE EASEMENT GRANTED TO A.B.C.W.U.A.
- (Q) NEW 20' SAS EASEMENT GRANTED TO A.B.C.W.U.A.
- (R) NEW 20' PUBLIC STORM DRAIN EASEMENT
- (S) NEW 25' PUBLIC STORM DRAIN EASEMENT
- (T) NEW 20' WATERLINE EASEMENT GRANTED TO A.B.C.W.U.A.

PROPERTY CORNERS

- (O) FOUND 5/8" REBAR WITH CAP "LS 7719" (TYP)

LEGEND

- 1 LOT NUMBER
- (17) BLOCK NUMBER
- ▲ CENTER LINE MONUMENT
- ROW RIGHT-OF-WAY

