

landscapiforms Drawing: PK163-03  
Dimensions are in inches (mm)

CONFIDENTIAL DRAWING INFORMATION CONTAINED HEREIN IS THE PROPERTY OF LANDSCAPE FORMS, INC. INTENDED USE IS LIMITED TO DESIGN PROFESSIONALS SPECIFYING LANDSCAPE FORMS, INC. PRODUCTS AND THEIR DIRECT CLIENTS. DRAWING IS NOT TO BE COPIED OR DISCLOSED TO OTHERS WITHOUT THE CONSENT OF LANDSCAPE FORMS, INC. © 2013 LANDSCAPE FORMS, INC. ALL RIGHTS RESERVED.

NOTES:

- 1) CONTRACTOR SHALL USE THE SAME, OR CLOSEST EQUIVALENT, BENCH TO APPROVED MASTER PLANS
- 2) LOCATION TO BE SET IN THE FIELD.

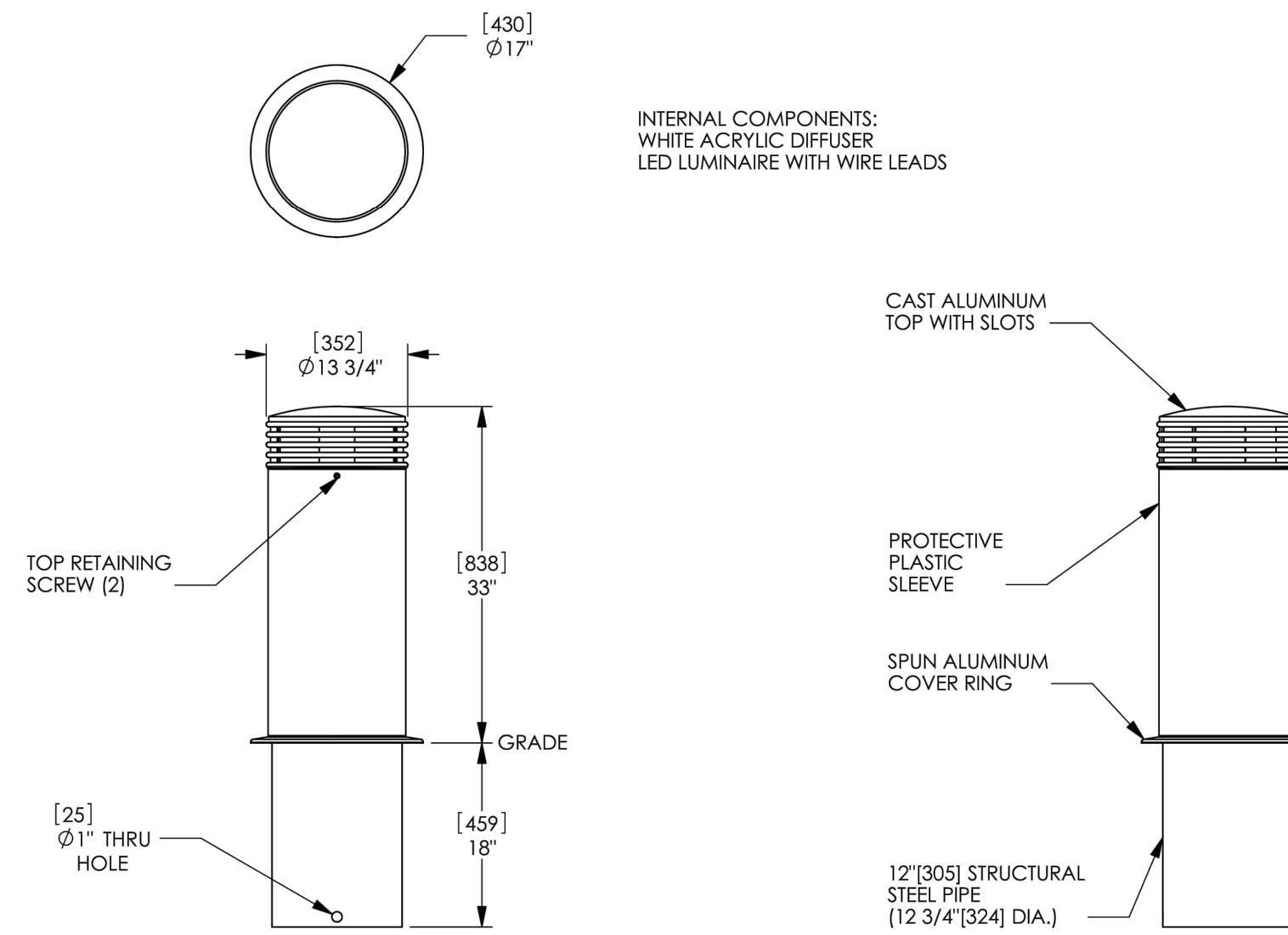

landscapiforms Drawing: AN448-04  
Dimensions are in inches (mm)

INTERNAL COMPONENTS:  
WHITE ACRYLIC DIFFUSER  
LED LUMINAIRE WITH WIRE LEADS

CAST ALUMINUM TOP WITH SLOTS

PROTECTIVE PLASTIC SLEEVE

SPUN ALUMINUM COVER RING

12" [305] STRUCTURAL STEEL PIPE (12 3/4" [324] DIA.)

CONFIDENTIAL DRAWING INFORMATION CONTAINED HEREIN IS THE PROPERTY OF LANDSCAPE FORMS, INC. INTENDED USE IS LIMITED TO DESIGN PROFESSIONALS SPECIFYING LANDSCAPE FORMS, INC. PRODUCTS AND THEIR DIRECT CLIENTS. DRAWING IS NOT TO BE COPIED OR DISCLOSED TO OTHERS WITHOUT THE CONSENT OF LANDSCAPE FORMS, INC. © 2013 LANDSCAPE FORMS, INC. ALL RIGHTS RESERVED.

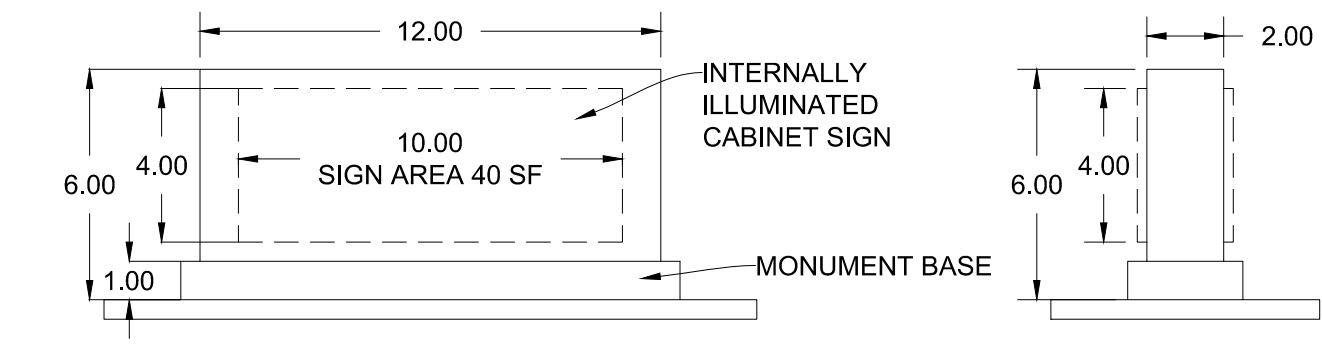

MONUMENT SIGN ELEVATIONS (SIGN TYPE A)  
N.T.S.

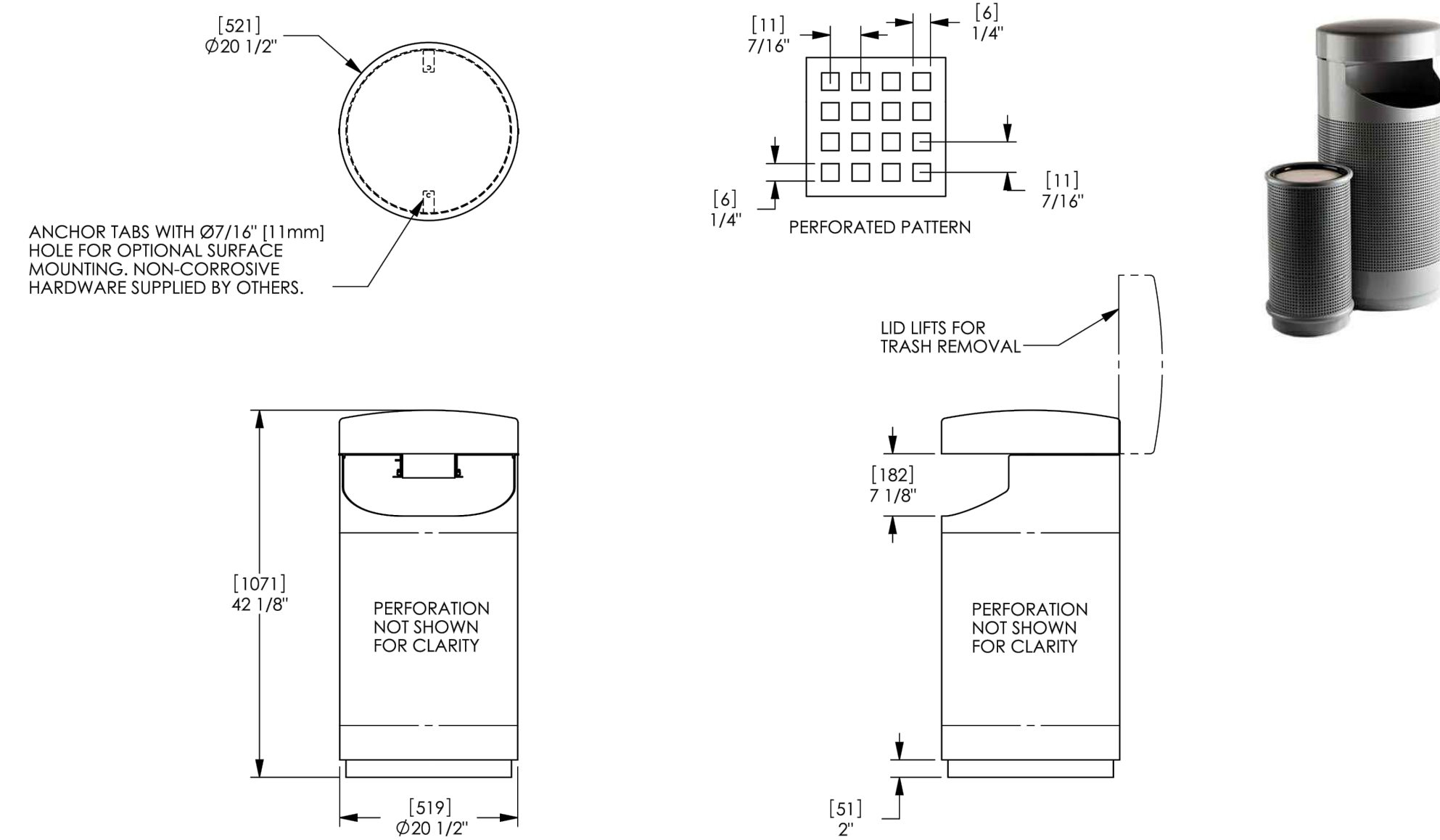

landscapiforms Drawing: PK166-01  
Dimensions are in inches (mm)

CONFIDENTIAL DRAWING INFORMATION CONTAINED HEREIN IS THE PROPERTY OF LANDSCAPE FORMS, INC. INTENDED USE IS LIMITED TO DESIGN PROFESSIONALS SPECIFYING LANDSCAPE FORMS, INC. PRODUCTS AND THEIR DIRECT CLIENTS. DRAWING IS NOT TO BE COPIED OR DISCLOSED TO OTHERS WITHOUT THE CONSENT OF LANDSCAPE FORMS, INC. © 2014 LANDSCAPE FORMS, INC. ALL RIGHTS RESERVED.

NOTES:

- 1) CONTRACTOR SHALL USE THE SAME, OR CLOSEST EQUIVALENT, BENCH TO APPROVED MASTER PLANS
- 2) LOCATION TO BE SET IN THE FIELD.

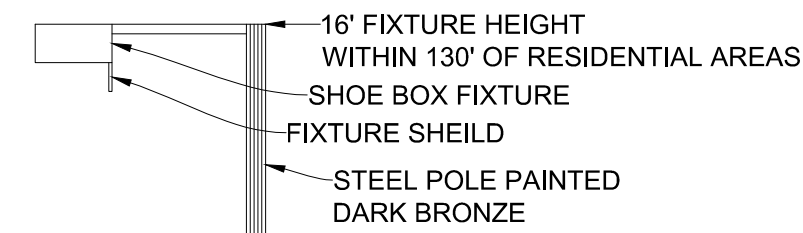

NOTES:  
1) LIGHTS TO BE HORIZONTAL LAMPS WITH SHIELDED FIXTURES  
2) RE: ARCHITECTURAL DESIGN GUIDELINE DRAWING FOR ADDITIONAL LIGHTING INFORMATION

LIGHT POLE DETAIL  
N.T.S.

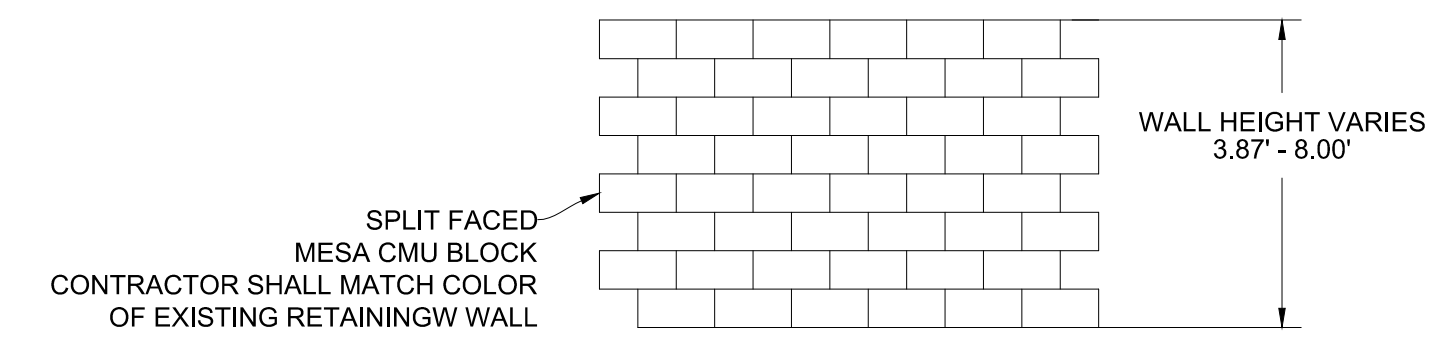

RETAINING WALL ELEV. (TYP SECTION)  
N.T.S.

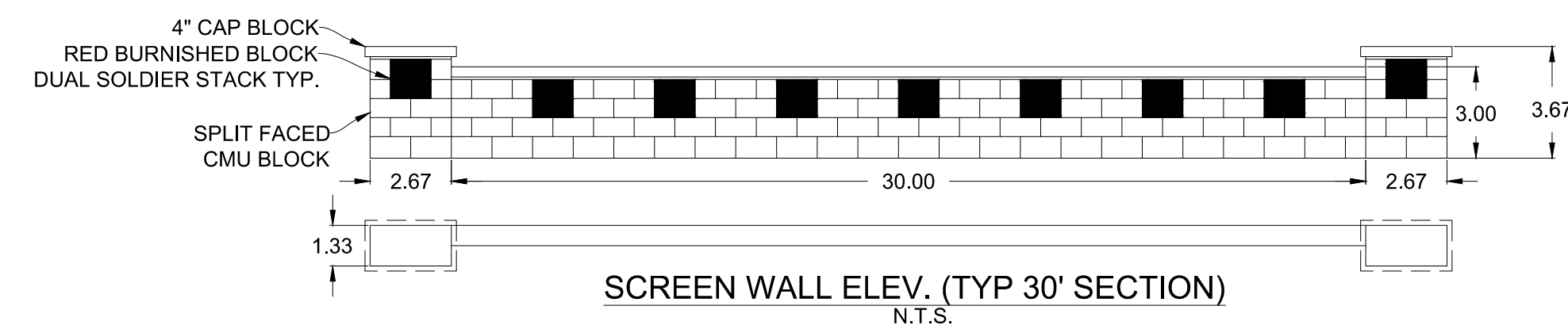

SCREEN WALL ELEV. (TYP 30' SECTION)  
N.T.S.

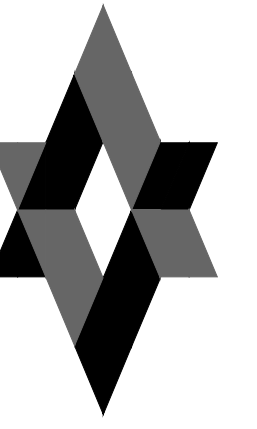

MARK D. MCCLUGGAGE AIA, CCS  
1525 E. Douglas Wichita, KS 67211  
Tel: (316) 266-9400  
www.hcieng.com



Main: 303.623.9116 | Direct: 720.545.0459  
3734 Osage Street | Denver, CO 80211  
CONTACT: LANCE VANDEMARK, P.E.

12134.230

- △EPC 1ST SUB 03.30.16
- △EPC 2ND SUB 05.02.16
- △DRB 1ST SUB 10.03.16

CONTRACT DATE: APRIL 24, 2016  
BUILDING TYPE: EXPLORER MED54  
PLAN VERSION: APRIL 2015 (N)  
SITE NUMBER:  
STORE NUMBER:

TACO BELL

UNSER BLVD  
ALBUQUERQUE, NM 87114



EXPLORER  
MEDIUM40

DETAIL  
SHEET 2

D2.0