

Vicinity Map - Zone Atlas D-20-Z

Purpose of Plat

1. SUBDIVIDE AS SHOWN HEREON.

Legal Description

PARCEL LETTERED "A" OF THE PLAT OF PARCELS A, B AND C, VENTURA PLAZA, WITHIN THE ELENA GALLEGOS GRANT IN PROJECTED SECTION 20, TOWNSHIP 11 NORTH, RANGE 4 EAST, NEW MEXICO PRINCIPAL MERIDIAN, CITY OF ALBUQUERQUE, BERNALILLO COUNTY, NEW MEXICO, AS THE SAME IS SHOWN AND DESIGNATED ON SAID PLAT THEREOF, FILED IN THE OFFICE OF THE COUNTY CLERK OF BERNALILLO COUNTY, NEW MEXICO, ON APRIL 3, 2008, IN PLAT BOOK 2008C, PAGE 63 AS DOCUMENT NO. 2008038110.

Free Consent

THE REAL ESTATE SHOWN AND DESCRIBED ON THIS PLAT IS SURVEYED AND SUBDIVIDED WITH THE FREE CONSENT OF AND IN ACCORDANCE WITH THE WISHES OF THE UNDERSIGNED OWNER(S) THEREOF.

Jabeen Vagh, AS MANAGING MEMBER
 PASEO 2010, LLC, A NEW MEXICO LIMITED LIABILITY COMPANY

STATE OF New Mexico }
 COUNTY OF Sandoval } SS

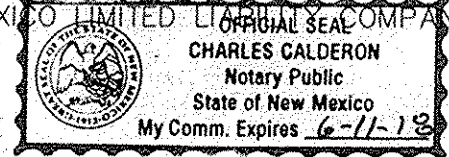

THIS INSTRUMENT WAS ACKNOWLEDGED BEFORE ME ON 7th of August, 2017
 BY: JABEEN VAGH, AS MANAGING MEMBER OF PASEO 2010, LLC, A NEW MEXICO LIMITED LIABILITY COMPANY

By: [Signature]
 NOTARY PUBLIC

MY COMMISSION EXPIRES June 11, 2018

Indexing Information

Projected Section 20, Township 11 North, Range 4 East,
 N.M.P.M., Elena Gallegos Grant
 Subdivision: Ventura Plaza
 Owner: Paseo 2010, LLC
 UPC #: 102006321548520595

DOCH 2017092368

09/25/2017 03:35 PM Page: 1 of 4
 PLAT #: 208.08 B: 2017C P: 0105 Linda Stover, Bernalillo County

Subdivision Data

GROSS ACREAGE.....3.2792 ACRES
 ZONE ATLAS PAGE NO.....D-20-Z
 NUMBER OF EXISTING LOTS.....1
 NUMBER OF LOTS CREATED.....2
 MILES OF FULL-WIDTH STREETS.....0.000 MILES
 MILES OF HALF-WIDTH STREETS.....0.000 MILES
 RIGHT-OF-WAY DEDICATION TO THE CITY OF ALBUQUERQUE.....0.000 ACRES
 DATE OF SURVEY.....JULY 2017

Notes

1. FIELD SURVEY PERFORMED IN DECEMBER 2016, JANUARY 2017, JUNE 2017 AND JULY 2017.
2. ALL DISTANCES ARE GROUND DISTANCES: U.S. SURVEY FOOT.
3. THE BASIS OF BEARINGS REFERENCES NEW MEXICO STATE PLANE COORDINATES (NAD-83-GROUND) USING GROUND TO GRID FACTOR OF 0.999648569.

Solar Collection Note

PER SECTION 14-14-4-7 OF THE SUBDIVISION ORDINANCE:

NO PROPERTY WITHIN THE AREA OF REQUESTED FINAL ACTION SHALL AT ANY TIME BE SUBJECT TO A DEED RESTRICTION, COVENANT, OR BUILDING AGREEMENT PROHIBITING SOLAR COLLECTORS FROM BEING INSTALLED ON BUILDINGS OR ERECTED ON THE LOTS OR PARCELS WITHIN THE AREA OF PROPOSED PLAT, THE FOREGOING REQUIREMENT SHALL BE A CONDITION TO APPROVAL OF THIS PLAT.

Public Utility Easements

PUBLIC UTILITY EASEMENTS shown on this plat are granted for the common and joint use of:

- A. Public Service Company of New Mexico ("PNM"), a New Mexico corporation, (PNM Electric) for installation, maintenance, and service of overhead and underground electrical lines, transformers, and other equipment and related facilities reasonably necessary to provide electrical services.
- B. New Mexico Gas Company for installation, maintenance, and service of natural gas lines, valves and other equipment and facilities reasonably necessary to provide natural gas services.
- C. Qwest Corporation d/b/a CenturyLink QC for the installation, maintenance, and service of such lines, cable, and other related equipment and facilities reasonably necessary to provide communication services.
- D. Cable TV for the installation, maintenance, and service of such lines, cable, and other related equipment and facilities reasonably necessary to provide Cable services.

Included, is the right to build, rebuild, construct, reconstruct, locate, relocate, change, remove, replace, modify, renew, operate and maintain facilities for purposes described above, together with free access to, from, and over said easements, with the right and privilege of going upon, over and across adjoining lands of Grantor for the purposes set forth herein and with the right to utilize the right of way and easement to extend services to customers of Grantee, including sufficient working area space for electric transformers, with the right and privilege to trim and remove trees, shrubs or bushes which interfere with the purposes set forth herein. No building, sign, pool (aboveground or subsurface), hot tub, concrete or wood pool decking, or other structure shall be erected or constructed on said easements, nor shall any well be drilled or operated thereon. Property owners shall be solely responsible for correcting any violations of National Electrical Safety Code by construction of pools, decking, or any structures adjacent to or near easements shown on this plat.

Easements for electric transformer/switchgears, as installed, shall extend ten (10) feet in front of transformer/switchgear doors and five (5) feet on each side.

Disclaimer

In approving this plat, Public Service Company of New Mexico (PNM) and New Mexico Gas Company (NMGC) did not conduct a Title Search of the properties shown hereon. Consequently, PNM and NMGC do not waive or release any easement or easement rights which may have been granted by prior plat, replat or other document and which are not shown on this plat.

Treasurer's Certificate

THIS IS TO CERTIFY THAT THE TAXES ARE CURRENT AND

PAID ON UPC # 102006321548520595

PROPERTY OWNER OF RECORD

Paseo 2010 LLC

BERNALILLO COUNTY TREASURER'S OFFICE

George Stone 9-26-17

Plat for
 Parcels A-1 and A-2
 Ventura Plaza
 Being Comprised of
 Parcel A
 Ventura Plaza
 City of Albuquerque
 Bernalillo County, New Mexico
 August 2017

Approved and Accepted by:

APPROVAL AND CONDITIONAL ACCEPTANCE AS SPECIFIED BY THE ALBUQUERQUE SUBDIVISION ORDINANCE, CHAPTER 14 ARTICLE 14 OF THE REVISED ORDINANCES OF ALBUQUERQUE, NEW MEXICO, 1994.

Project Number: 1006602

Application Number: 17DRB-70216

Plat Approvals:

- [Signature] 8-17-17
PNM Electric Services
- [Signature] 8/11/2017
Qwest Corp. d/b/a CenturyLink QC
- [Signature] 8.9.17
New Mexico Gas Company
- [Signature] 8/9/17
Comcast

City Approvals:

- [Signature] P.S. 8/7/17
City Surveyor
- [Signature] 08-15-17
Traffic Engineer
- [Signature] 08-18-17
ABCWUA
- [Signature] 8/16/17
Parks and Recreation Department
- [Signature] 8-17-17
AMAFCA
- [Signature] 8/16/17
City Engineer
- [Signature] 8/23/17
DRB Chairperson, Planning Department

Surveyor's Certificate

"I, WILL PLOTNER JR., A REGISTERED PROFESSIONAL LAND SURVEYOR UNDER THE LAWS OF THE STATE OF NEW MEXICO, DO HEREBY CERTIFY THAT THIS PLAT AND DESCRIPTION WERE PREPARED BY ME OR UNDER MY SUPERVISION, SHOWS ALL EASEMENTS AS SHOWN ON THE PLAT OF RECORD OR MADE KNOWN TO ME BY THE OWNERS AND/OR PROPRIETORS OF THE SUBDIVISION SHOWN HEREON, THE UTILITY COMPANIES OR OTHER INTERESTED PARTIES AND MEETS THE MINIMUM REQUIREMENTS FOR MONUMENTATION AND SURVEYS OF THE ALBUQUERQUE SUBDIVISION ORDINANCE, AND FURTHER MEETS THE MINIMUM STANDARDS FOR LAND SURVEYING IN THE STATE OF NEW MEXICO AND IS TRUE AND CORRECT TO THE BEST OF MY KNOWLEDGE AND BELIEF."

[Signature] 8/2/17
 Will Plotner Jr.
 N.M.R.P.S. No. 14271

CARTESIAN SURVEYS INC.

P.O. BOX 44414 RIO RANCHO, N.M. 87174
 Phone (505) 896-3050 Fax (505) 891-0244



**Plat for
 Parcels A-1 and A-2
 Ventura Plaza
 Being Comprised of
 Parcel A
 Ventura Plaza
 City of Albuquerque
 Bernalillo County, New Mexico
 August 2017**

Legend

N 90°00'00" E	MEASURED BEARINGS AND DISTANCES
(N 90°00'00" E)	RECORD BEARINGS AND DISTANCES (4/3/2008, 8C-63)
●	FOUND MONUMENT AS INDICATED
○	SET BATHEY MARKER "LS 14271" UNLESS OTHERWISE NOTED

ACS Monument " 6-C21 "
 NAD 1983 CENTRAL ZONE
 X=1555754.364 *
 Y=1523064.716 *
 Z=5660.507 * (NAVD 1988)
 G-G=0.999641314
 Mapping Angle=-0°09'47.79"
 * U.S. Survey Feet

** LINE TABLE AND CURVE TABLE
 LOCATED ON SHEET 4

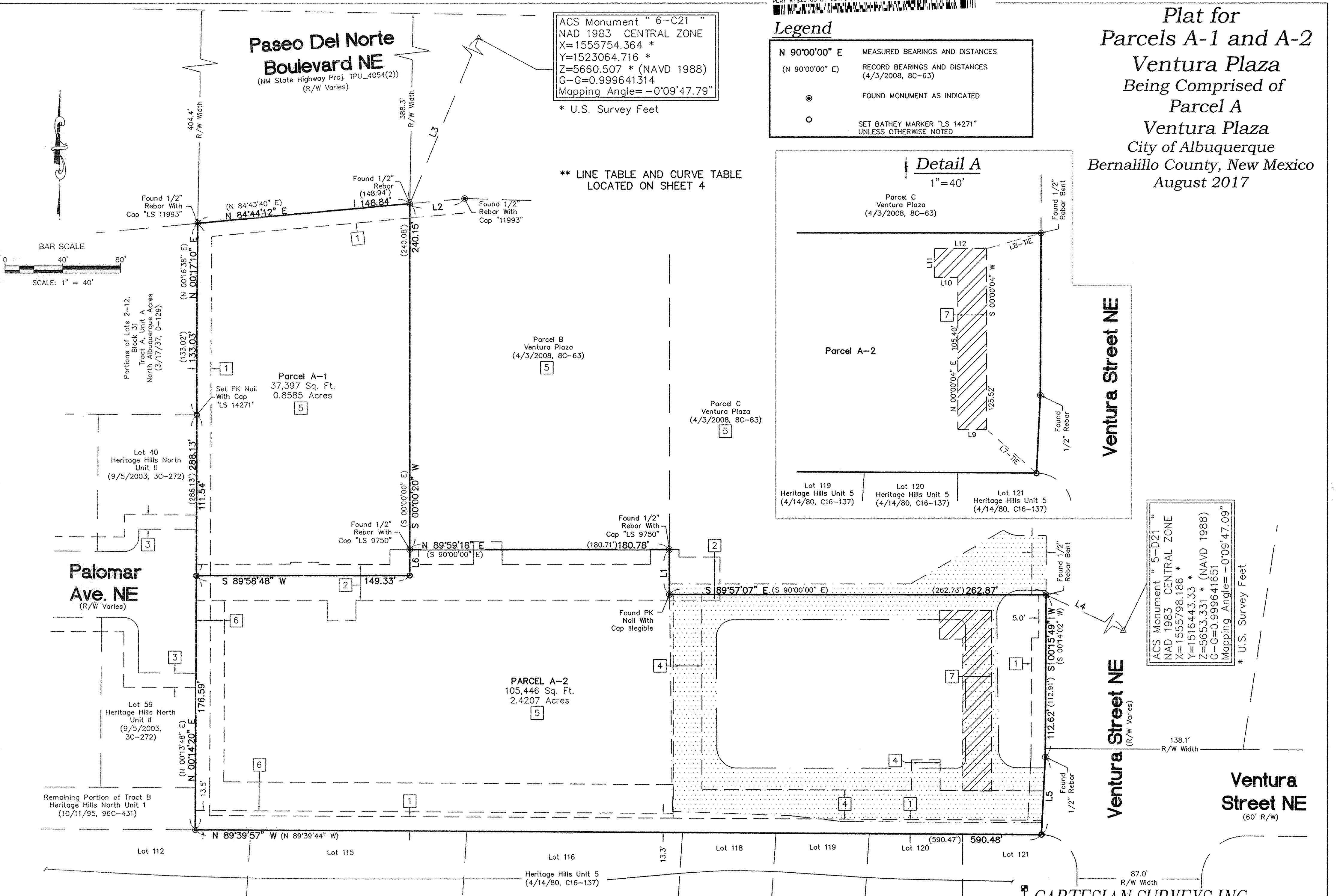
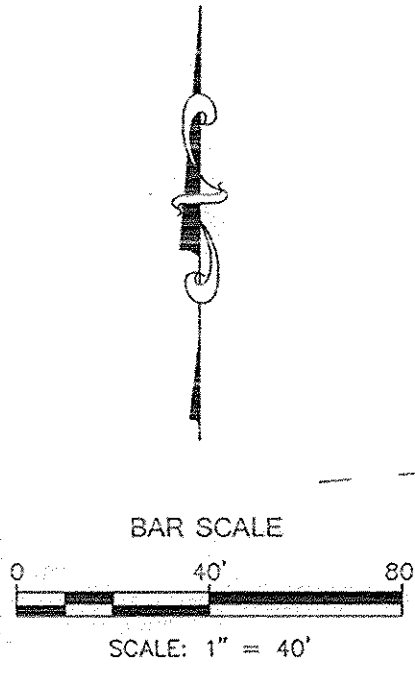
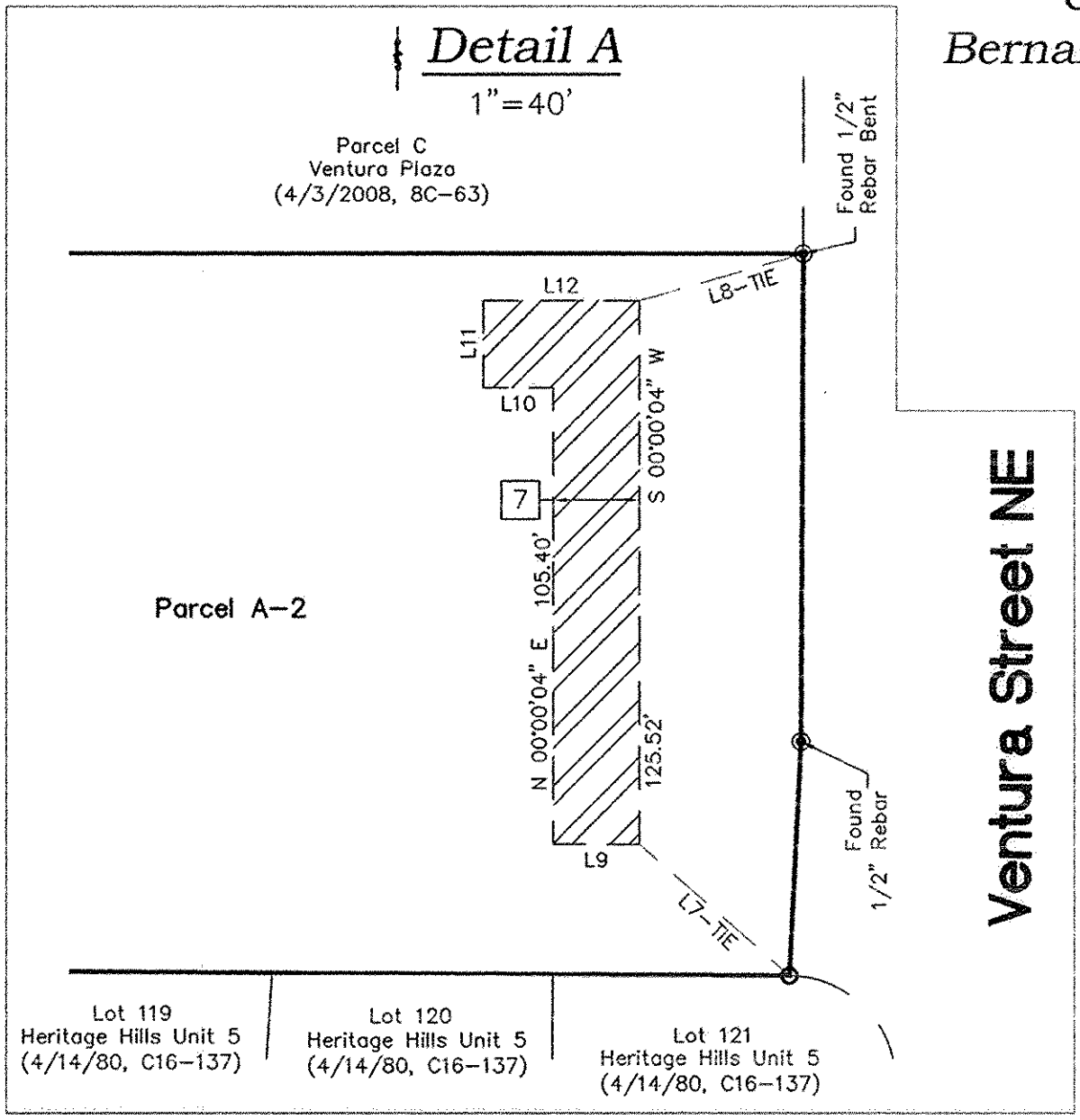

ACS Monument " 5-D21 "
 NAD 1983 CENTRAL ZONE
 X=1555798.186 *
 Y=1516443.33 *
 Z=5653.331 * (NAVD 1988)
 G-G=0.999641651
 Mapping Angle=-0°09'47.09"
 * U.S. Survey Feet

Plat for
 Parcels A-1 and A-2
 Ventura Plaza
 Being Comprised of
 Parcel A
 Ventura Plaza
 City of Albuquerque
 Bernalillo County, New Mexico
 August 2017

Easement Notes

- 1 EXISTING 10' P.U.E. (4/3/2008, 08C-63)
- 2 EXISTING 25' PUBLIC SANITARY SEWER AND WATERLINE EASEMENT GRANTED TO THE ALBUQUERQUE BERNALILLO COUNTY WATER UTILITY AUTHORITY (4/3/2008, 08C-63) - SEE DETAIL D-THIS SHEET
 - 2a THAT PORTION OF EASEMENT 2 NOW AFFECTING PARCEL A-1 DEFINED BY THIS PLAT AND ON THIS SHEET BY [Symbol]
 - 2b THAT PORTION OF EASEMENT 2 NOW AFFECTING PARCEL A-2 AS DEFINED BY THIS PLAT AND ON THIS SHEET BY [Symbol]
- 3 EXISTING 10' P.U.E. (9/5/2003, 03C-272)
- 4 EXISTING 20' PUBLIC WATERLINE EASEMENT GRANTED TO THE ALBUQUERQUE BERNALILLO COUNTY WATER UTILITY AUTHORITY (4/3/2008, 08C-63) - SEE DETAIL C-THIS SHEET
- 5 EXISTING NON-EXCLUSIVE, RECIPROCAL UTILITY, DRAINAGE AND ACCESS EASEMENT FOR VEHICULAR AND PEDESTRIAN INGRESS AND EGRESS, BLANKET IN NATURE (4/3/2008, DOC. NO. 2008038109 AND RATIFIED 6/17/08, DOC. NO. 2008068606) AS PER ARTICLE I OF THE DECLARATION OF COVENANTS, CONDITIONS, RESTRICTIONS AND CROSS-EASEMENTS: "COMMON AREA" SHALL MEAN ALL OF THOSE AREAS ON EACH PARCEL WHICH ARE NOT FROM TIME TO TIME, AND AT ANY APPLICABLE TIME, OCCUPIED BY BUILDINGS. COMMON AREA SHALL INCLUDE ALL PRIVATE STREETS, DRIVEWAYS, AREAS OF INGRESS AND EGRESS, PARKING AREAS, SERVICE AREAS, SIDEWALKS AND OTHER PEDESTRIAN WAYS, LANDSCAPE AREAS, SERVICE AREAS, SIDEWALKS AND OTHER PEDESTRIAN WAYS, LANDSCAPE AREAS AND SIMILAR AMENITIES DESIGNATED AND MAINTAINED FOR SUCH USES FROM TIME TO TIME. EXCEPT FOR THE ACCESS EASEMENTS GRANTED IN SECTION 2.01 (INGRESS AND EGRESS EASEMENTS), THE OWNER OF EACH PARCEL SHALL HAVE THE RIGHT TO CHANGE THE COMMON AREA AT ANY TIME AND FROM TIME TO TIME, PROVIDED ACCESS AS HEREINAFTER GRANTED IS NOT ADVERSELY AFFECTED. COMMON AREA SHALL SPECIFICALLY NOT INCLUDE THE DRIVE-THRU WINDOW AREA OF THE WALGREENS BUILDING OR ANY DRIVE-THRU WINDOW AREA WHICH EXISTS FROM TIME TO TIME ON EITHER PARCEL. THIS INCLUDES ALL INGRESS/EGRESS EASEMENTS, UTILITY EASEMENTS, AND DRAINAGE EASEMENTS.

[Symbol] COMMON ACCESS DRIVEWAY AS PER ARTICLE II, EXHIBIT A (SEE DETAIL B-THIS SHEET)
- 6 EXISTING TEMPORARY 20' WATERLINE EASEMENT (4/3/2008, DOC. NO. 2008038111)
- 7 EXISTING 20' PERMANENT ALBUQUERQUE BERNALILLO COUNTY WATER UTILITY AUTHORITY (ABCWUA) EASEMENT (2/9/2009, DOC. NO. 2009012723), SHOWN HEREON AS [Symbol], SEE DETAIL A-SHEET 2

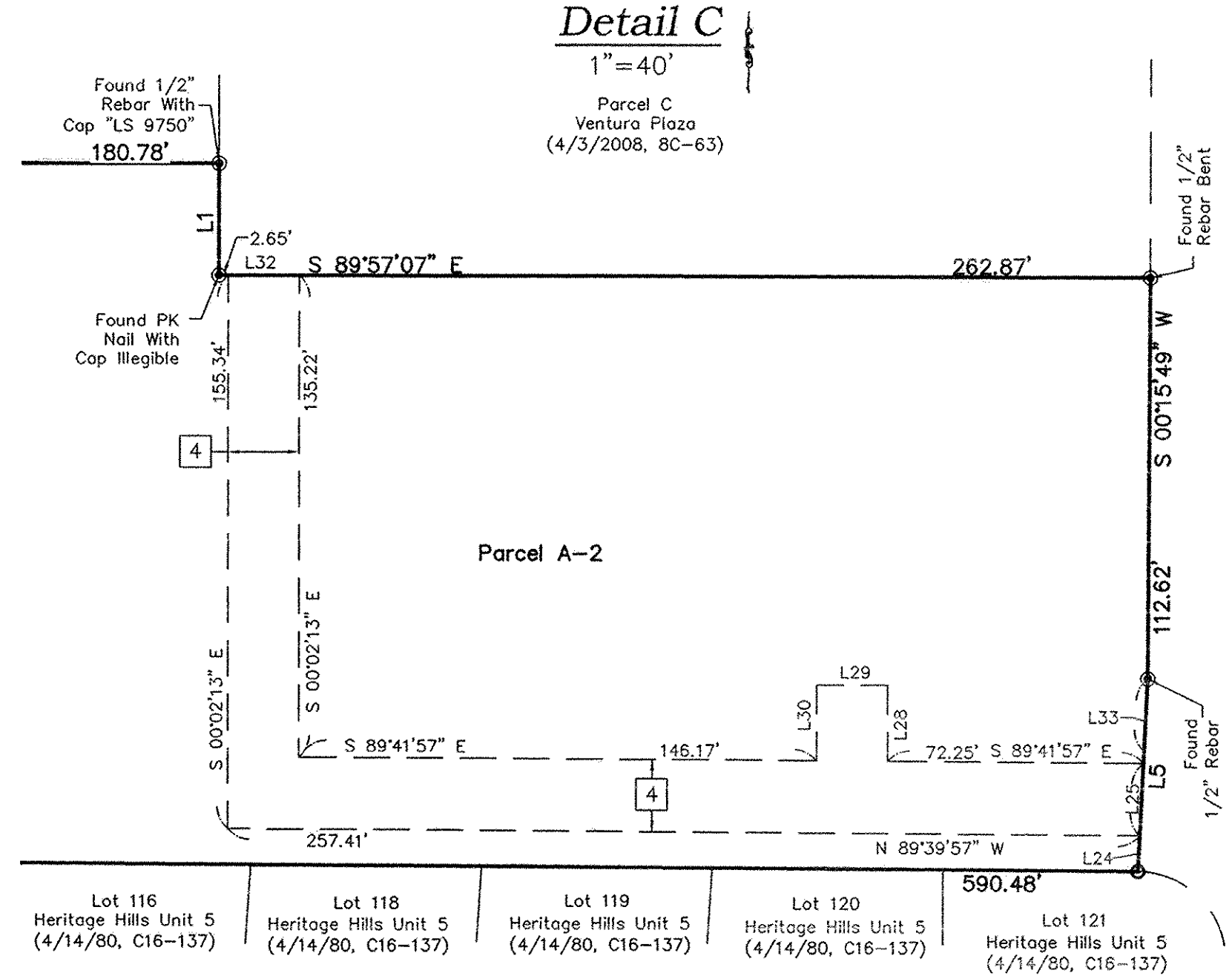
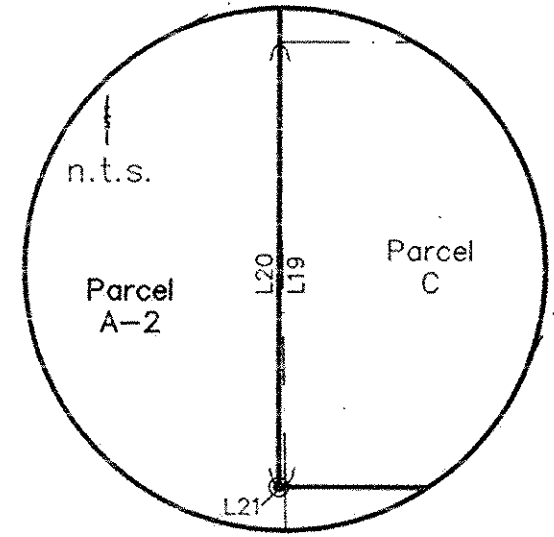
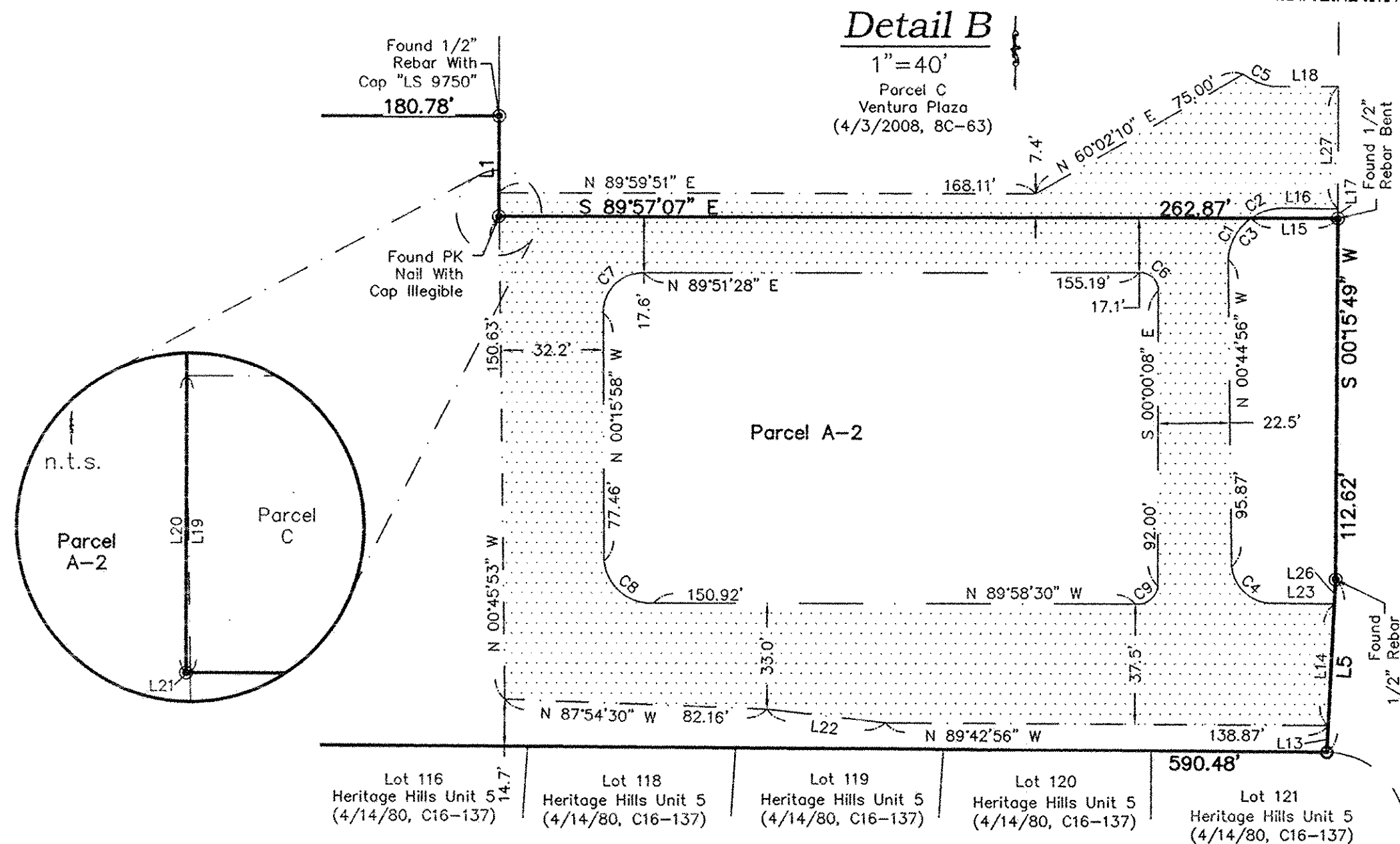

Detail D
 1"=40'

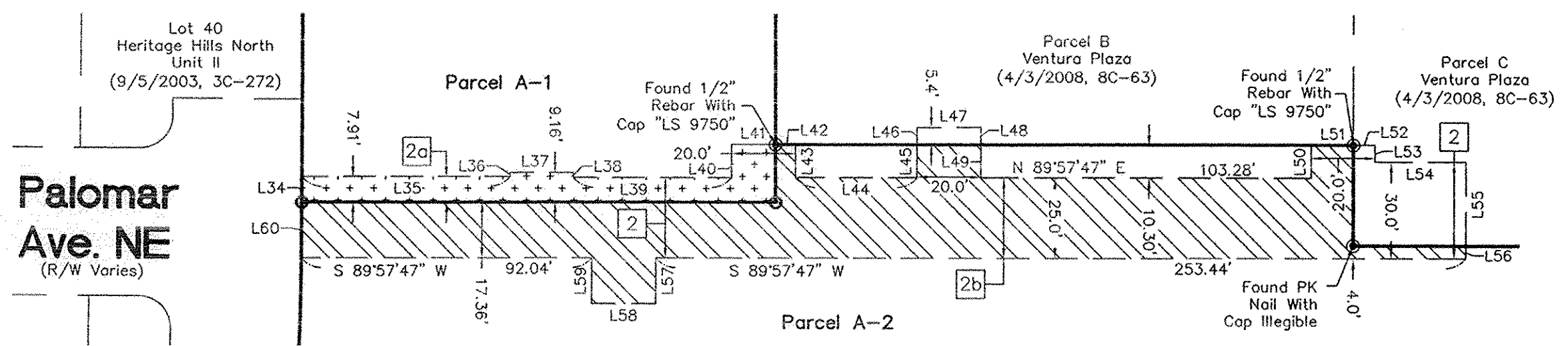

Ventura Street NE
 (R/W Varies)

Ventura Street NE
 (R/W Varies)

Palomar Ave. NE
 (R/W Varies)

** LINE TABLE AND CURVE TABLE
 LOCATED ON SHEET 4

CARTESIAN SURVEYS INC.

P.O. BOX 44414 RIO RANCHO, N.M. 87174
 Phone (505) 896-3050 Fax (505) 891-0244

*Plat for
 Parcels A-1 and A-2
 Ventura Plaza
 Being Comprised of
 Parcel A
 Ventura Plaza
 City of Albuquerque
 Bernalillo County, New Mexico
 August 2017*

Line Table		
Line #	Direction	Length (ft)
L1	S 00°03'24" W (S 00°00'00" W)	31.30' (31.33')
L2	N 84°44'12" E (N 84°43'40" E)	38.25' (38.17')
L3	N 36°13'45" E	5391.11'
L4	S 54°17'09" E	3431.85'
L5	S 02°51'19" W (S 02°47'51" W)	54.07' (54.07')
L6	S 00°01'01" E	18.01'
L7	S 49°07'08" E	46.14'
L8	N 74°01'47" E	39.62'
L9	N 89°39'40" W	20.00'
L10	N 89°59'56" W	16.18'
L11	N 00°00'04" E	20.00'
L12	S 89°59'56" E	36.18'
L13	S 02°51'19" W	8.35'
L14	N 02°51'19" E	38.13'
L15	N 89°57'07" W	27.25'
L16	S 89°13'42" E	17.24'
L17	N 00°05'37" E	3.02'
L18	N 89°59'37" W	20.69'
L19	S 00°45'53" E	7.26'
L20	N 00°03'24" E	7.26'

Line Table		
Line #	Direction	Length (ft)
L21	N 89°57'07" W	0.10'
L22	S 83°31'40" E	37.23'
L23	N 89°33'19" W	20.92'
L24	N 02°51'50" E	9.98'
L25	N 02°51'19" E	20.38'
L26	N 02°49'41" E	7.58'
L27	N 00°05'37" E	38.13'
L28	S 00°02'34" E	21.31'
L29	N 89°57'26" E	20.01'
L30	N 00°02'34" W	21.19'
L32	S 89°57'07" E	20.00'
L33	N 02°51'19" E	23.69'
L34	N 00°14'20" E	7.90'
L35	S 89°57'47" W	66.20'
L36	S 00°02'13" E	1.23'
L37	S 89°57'47" W	20.00'
L38	N 00°03'17" W	1.51'
L39	S 89°57'47" W	49.35'
L40	S 00°02'13" E	10.35'
L41	S 89°57'06" W	13.75'

Line Table		
Line #	Direction	Length (ft)
L42	S 89°59'18" W	6.25'
L43	N 00°02'13" W	10.35'
L44	S 89°57'47" W	38.00'
L45	S 00°02'13" E	10.33'
L46	S 00°02'13" E	5.41'
L47	S 89°57'47" W	20.00'
L48	N 00°02'13" W	5.42'
L49	N 00°02'13" W	10.32'
L50	S 00°02'13" E	10.26'
L51	S 89°54'56" W	13.25'
L52	S 89°54'56" W	6.75'
L53	N 00°02'13" W	5.27'
L54	S 89°57'47" W	28.53'
L55	N 00°02'13" W	26.08'
L56	N 00°02'13" W	3.92'
L57	N 00°02'13" W	14.19'
L58	N 89°57'47" E	20.00'
L59	S 00°02'13" E	14.19'
L60	N 00°14'20" E	17.37'

* L31 - INTENTIONALLY OMITTED

Curve Table					
Curve #	Length	Radius	Delta	Chord Length	Chord Direction
C1	15.23'	17.20'	50°44'28"	14.74'	N 28°58'05" E
C2	10.70'	17.20'	35°39'22"	10.53'	N 72°09'14" E
C3	25.93'	17.20'	86°23'04"	23.54'	S 46°47'23" W
C4	17.26'	12.87'	76°50'11"	16.00'	N 45°01'50" W
C5	10.02'	20.36'	28°11'25"	9.91'	N 67°28'43" W
C6	9.27'	5.64'	94°08'42"	8.26'	N 46°49'14" W
C7	19.89'	12.15'	93°46'18"	17.74'	S 45°31'22" W
C8	22.46'	14.66'	87°45'10"	20.33'	S 50°03'17" E
C9	10.06'	6.43'	89°35'36"	9.06'	N 50°41'22" E