



Supplemental form

SUBDIVISION S

Z

Major Subdivision action

Minor Subdivision action

Vacation V

Variance (Non-Zoning)

SITE DEVELOPMENT PLAN D

L

A

for Subdivision Purposes

for Building Permit

Administrative Amendment (AA)

IP Master Development Plan

Cert. of Appropriateness (LUCC)

STORM DRAINAGE (Form D)

Storm Drainage Cost Allocation Plan

ZONING & PLANNING

Annexation

County Submittal

EPC Submittal

Zone Map Amendment (Establish or Change Zoning)

Sector Plan (**Phase I, II, III**)

Amendment to Sector, Area, Facility or Comprehensive Plan

Text Amendment (Zoning Code/Sub Regs)

Street Name Change (Local & Collector)

APPEAL / PROTEST of...

Decision by: DRB, EPC, LUCC, Planning Director or Staff, ZHE, Zoning Board of Appeal

PRINT OR TYPE IN BLACK INK ONLY. The applicant or agent must submit the completed application in person to the Planning Department Development Services Center, 600 2nd Street NW, Albuquerque, NM 87102. Fees must be paid at the time of application. Refer to supplemental forms for submittal requirements.

APPLICATION INFORMATION:

Professional/Agent (if any): Bohannan Huston, Inc. PHONE: (505) 823-1000

ADDRESS: 7500 Jefferson NE FAX (505) 798-7988

CITY: Albuquerque STATE NM ZIP 87109 E-MAIL: ypadilla@bhinc.com

APPLICANT: Pulte Development of New Mexico PHONE: 505-341-8591

ADDRESS: 7601 Jefferson St NE Suite 320 FAX: 505-761-9850

CITY: Albuquerque STATE NM ZIP 87109 E-MAIL: Kevin.Patton@PulteGroup.com

Proprietary interest in site: Owner **List all owners:** _____

DESCRIPTION OF REQUEST: SIA Extension

Is the applicant seeking incentives pursuant to the Family Housing Development Program? Yes. No.

SITE INFORMATION: ACCURACY OF THE LEGAL DESCRIPTION IS CRUCIAL! ATTACH A SEPARATE SHEET IF NECESSARY.

Lot or Tract No. TR N-2-A-1 PLAT OF DEL WEBB @ MIREHAVEN PHASE I (A REPL OF TRS N-2-A & N-2-F WATERSHED SUBD)

Block: _____ Unit: _____ Subdiv/Addn/TBKA: Mirehaven Subdivision

Existing Zoning: SU-2 for PDA Proposed zoning: No change MRGCD Map No _____

Zone Atlas page(s): H-8 \H-9 UPC Code: 100805942229341115

CASE HISTORY:

List any current or prior case number that may be relevant to your application (Proj., App., DRB-, AX_, Z_, V_, S_, etc.): _____

10006864

CASE INFORMATION:

Within city limits? Yes No Within 1000FT of a landfill? Yes No

No. of existing lots: _____ No. of proposed lots: _____ Total area of site (acres): 25.845 ac

LOCATION PROPERTY BY STREETS: On or Near: Tierra Pintada Blvd

Between: Arroyo Vista and Mirehaven Parkway

Check-off if project was previously reviewed by Sketch Plat/Plan X, or Pre-application Review Team . Date of review: July 29, 2014

SIGNATURE Yolanda Moyer DATE 6-29-16

(Print) Yolanda Padilla Moyer, P.E. Applicant Agent

FOR OFFICIAL USE ONLY

Form revised 9/01, 3/03, 7/03, 10/03, 04/04

<input type="checkbox"/> INTERNAL ROUTING	Application case numbers	Action	S.F.	Fees
<input type="checkbox"/> All checklists are complete	_____	_____	_____	\$ _____
<input type="checkbox"/> All fees have been collected	_____	_____	_____	\$ _____
<input type="checkbox"/> All case #s are assigned	_____	_____	_____	\$ _____
<input type="checkbox"/> AGIS copy has been sent	_____	_____	_____	\$ _____
<input type="checkbox"/> Case history #s are listed	_____	_____	_____	\$ _____
<input type="checkbox"/> Site is within 1000ft of a landfill	_____	_____	_____	\$ _____
<input type="checkbox"/> F.H.D.P. density bonus	_____	_____	_____	\$ _____
<input type="checkbox"/> F.H.D.P. fee rebate	_____	_____	_____	\$ _____
	Hearing date _____			Total \$ _____

Project # _____

Planner signature / date _____

FORM S(2): SUBDIVISION - D.R.B. PUBLIC HEARING

A **Bulk Land Variance** requires application on FORM-V in addition to application for subdivision on FORM-S.

MAJOR SUBDIVISION PRELIMINARY PLAT APPROVAL (DRB13)

- ___ 5 Acres or more: Certificate of No Effect or Approval
- ___ Proposed Preliminary Plat including the Grading Plan (folded to fit into an 8.5" by 14" pocket) **24 copies**
- ___ Proposed Infrastructure List
- ___ Signed Preliminary Pre-Development Facilities Fee Agreement for **Residential** development only
- ___ Design elevations & cross sections of perimeter walls **3 copies** (11" x 17" maximum)
- ___ Zone Atlas map with the entire property(ies) clearly outlined
- ___ Letter briefly describing, explaining, and justifying the request
- ___ Property owner's and City Surveyor's signature on the proposed plat
- ___ FORM DRWS Drainage Report, Water & Sewer availability statement filing information
- ___ Office of Community & Neighborhood Coordination inquiry response, notifying letter, certified mail receipts
- ___ Sign Posting Agreement
- ___ **Signed** Pre-Annexation Agreement if Annexation required.
- ___ TIS/AQIA Traffic Impact Study / Air Quality Impact Assessment form
- ___ Fee (see schedule)
- ___ List any original and/or related file numbers on the cover application

Preliminary plat approval expires after one year.

DRB Public hearings are approximately 30 DAYS after the filing deadline. Your attendance is required.

MAJOR SUBDIVISION AMENDMENT TO PRELIMINARY PLAT (DRB11) (with significant changes)

PLEASE NOTE: There are no clear distinctions between significant and minor changes with regard to subdivision amendments. Significant changes are those deemed by the DRB to require public notice and public hearing.

- ___ Proposed Amended Preliminary Plat, and/or Infrastructure List, and/or Grading Plan (folded to fit into an 8.5" by 14" pocket) **24 copies**
- ___ Original Preliminary Plat, and/or Infrastructure List, and/or Grading Plan (folded to fit into an 8.5" by 14" pocket)
- ___ Zone Atlas map with the entire property(ies) clearly outlined
- ___ Letter briefly describing, explaining, and justifying the request
- ___ Property owner's and City Surveyor's signature on the proposed amended plat, if applicable
- ___ Office of Community & Neighborhood Coordination inquiry response, notifying letter, certified mail receipts
- ___ Sign Posting Agreement
- ___ List any original and/or related file numbers are listed on the cover application

Amended preliminary plat approval expires after one year.

DRB Public hearings are approximately 30 DAYS after the filing deadline. Your attendance is required.

MAJOR SUBDIVISION IMPROVEMENTS AGREEMENT EXTENSION (DRB09)

(Temporary sidewalk deferral extension use FORM-V)

- ___ Zone Atlas map with the entire property(ies) clearly outlined
- ___ Letter briefly describing, explaining, and justifying the request
- ___ Plat or plan reduced to 8.5" x 11"
- ___ Official D.R.B. Notice of the original approval
- ___ Approved Infrastructure List. If not applicable, please initial. _____
- ___ Previous SIA extension notice, if one has been issued. If not applicable, please initial. _____
- ___ Office of Community & Neighborhood Coordination inquiry response, notifying letter, certified mail receipts
- ___ Sign Posting Agreement
- ___ List any original and/or related file numbers on the cover application
- ___ Fee (see schedule)

DRB Public hearings are approximately 30 DAYS after the filing deadline. Your attendance is required.

I, the applicant, acknowledge that any information required but not submitted with this application will likely result in deferral of actions.

Jolanda Moyer Applicant name (print)
Jolanda Moyer Applicant signature / date
 6-29-16



Form revised **October 2007**

- Checklists complete Application case numbers
- Fees collected _____ - _____
- Case #s assigned _____ - _____
- Related #s listed _____ - _____

_____ Planner signature / date
 _____ Project #

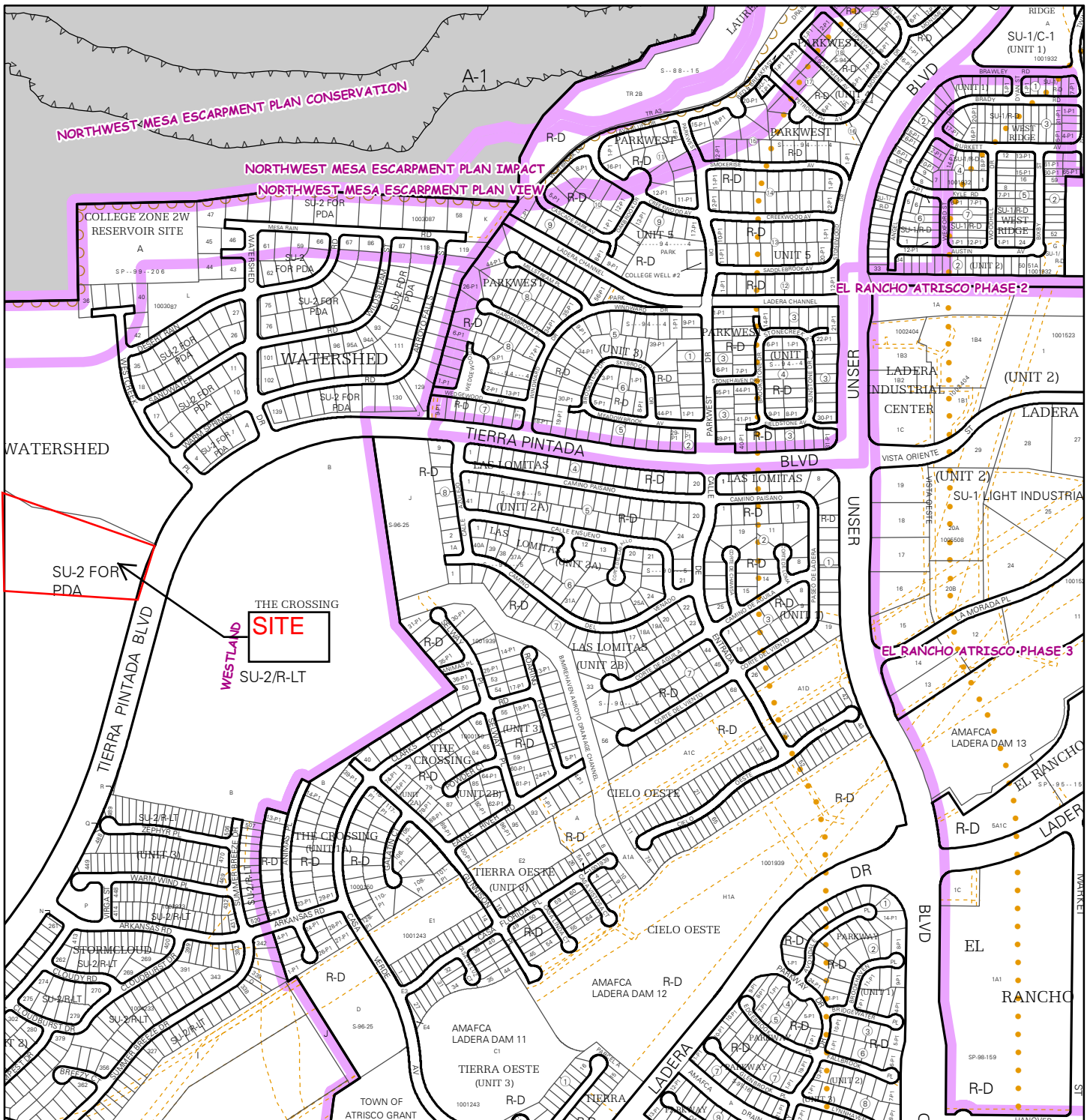

For more current information and details visit: <http://www.cabq.gov/gis>

Map amended through: 6/7/2013

Note: Grey Shading Represents Area Outside of the City Limits

Zone Atlas Page:
H-09-Z

Selected Symbols

- SECTOR PLANS
- Escarpment
- Design Overlay Zones
- 2 Mile Airport Zone
- City Historic Zones
- Airport Noise Contours
- H-1 Buffer Zone
- Wall Overlay Zone
- Petroglyph Mon.

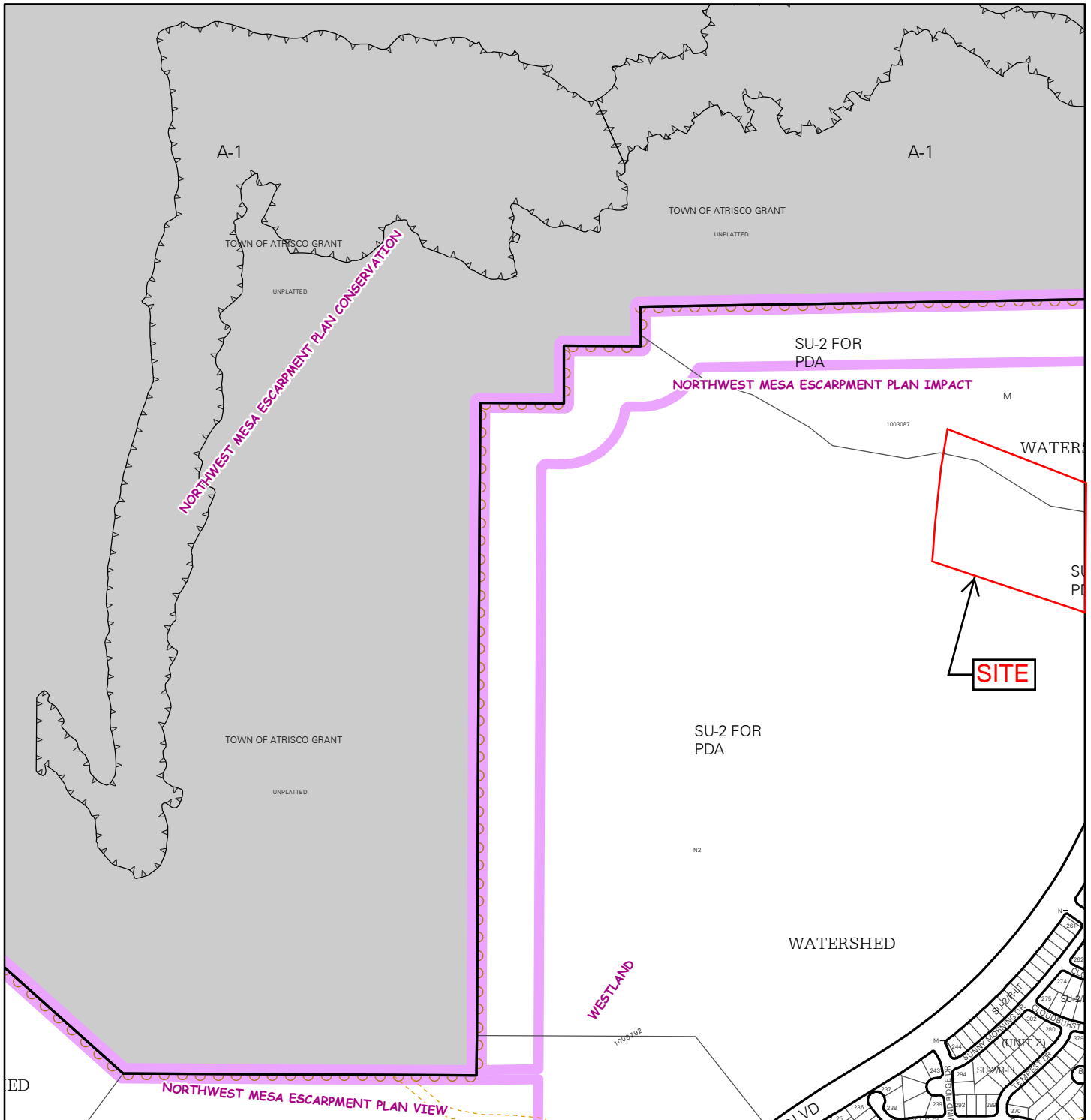

For more current information and details visit: <http://www.cabq.gov/gis>

AGIS
Albuquerque Geographic Information System

Note: Grey Shading Represents Area Outside of the City Limits

Zone Atlas Page:
H-08-Z

Selected Symbols

SECTOR PLANS	Escarpment
Design Overlay Zones	2 Mile Airport Zone
City Historic Zones	Airport Noise Contours
H-1 Buffer Zone	Wall Overlay Zone
Petroglyph Mon.	

0 750 1,500 Feet

Map amended through: 6/7/2013

June 29, 2016

Jack Cloud, Chair
Development Review Board
City of Albuquerque
PO Box 1293
Albuquerque, New Mexico 87103

Re: Subdivision Improvements Agreement Extension (Procedure B)
Tract N-2-A-1 (Mirehaven Arroyo) Del Webb @ Mirehaven Phase 1 - DRB #1006864

Dear Mr. Cloud:

Submitted for DRB review and approval is a request for an extension to the Subdivision Improvements Agreement for the above referenced project.

Enclosed is the following information:

- Applications for Development Review
- Zone Atlas sheet showing the project area
- Letter briefly describing, explaining, and justifying the request
- Plat 8 ½" x 11"
- Official Notice from the Development Review Board
- Approved Infrastructure List
- Original SIA, 1st Extension
- Neighborhood Notification information
- DRB Fee

We are requesting a two (2) year extension of the Subdivision Improvements Agreement (Procedure B) for the Mirehaven Arroyo infrastructure improvements for the above referenced project (CPN 650382). We are requesting the extension because the Mirehaven Arroyo Crossing (CPN 650386) has not been completed, which is a separate Work Order but is and integral part of the arroyo. Also the Floodplain is required to go through FEMA Letter of Map Revision process which can take between one and two years to be accepted. Therefore, we are requesting the approval of a two-year extension.

Please place this item on the DRB agenda to be heard on July 27, 2016. If you have any questions, or require further information, please call me.

Sincerely,



Yolanda Padilla Moyer, P.E.
Senior Project Manager
Community Development and Planning

YPM
Enclosures

Cc\ Kevin Patton, Pulte (w/encl)

Engineering ▲

Spatial Data ▲

Advanced Technologies ▲

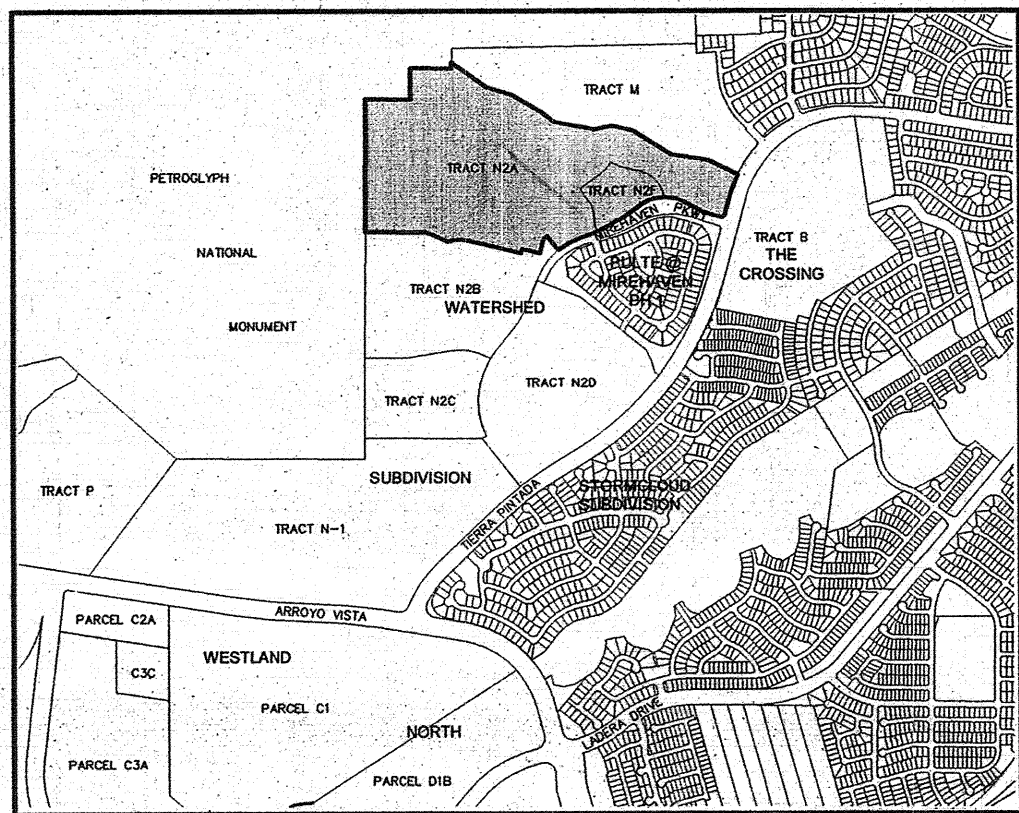

LOCATION MAP
NOT TO SCALE

DESCRIPTION

A certain tract of land located within the Town of Atrisco Grant, projected Sections 8 & 9, Township 10 North, Range 2 East, New Mexico Principal Meridian, City of Albuquerque, Bernalillo County, New Mexico, being and comprising all of Tracts "N-2-A" & "N-2-F", Watershed Subdivision, as the same is shown and designated on the plat thereof, filed in the office of the County Clerk of Bernalillo County, New Mexico on October 17, 2013 in Book 2013C page 116 as Document #2013115035.

Tract contains 91.3678 acres of land, more or less.

FREE CONSENT AND DEDICATION

The plat shown hereon is made with free consent and in accordance of the desires of the undersigned owner(s), the execution of this plat is their free act and deed. Those signing as owner(s) warrant that they hold among them, complete indefeasible title in fee simple to the land shown on this plat. Owner(s) hereby affirm that the described property shown on this plat lies within the platting and subdivision jurisdiction of Albuquerque, New Mexico. Said owner(s) hereby grant all Easements as shown on this plat. Access easements are permanent.

PULTE HOMES OF NEW MEXICO, INC.

BY: *Garret Price*
Garret Price, Vice President of Land
Pulte Homes of New Mexico, Inc.

State of New Mexico)
County of Sandoval)

This instrument was acknowledged before me on 17 day of June, 2014,
by Garret Price, Vice President of Land, Pulte Homes of New Mexico, Inc.

My Commission Expires: 9/22/14 *Pamela C. Alvarez*
Notary Public

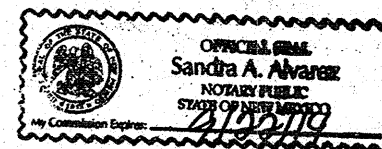

**PLAT OF
DEL WEBB @ MIREHAVEN
PHASE I**

(A REPLAT OF TRACTS N-2-A & N-2-F WATERSHED SUBDIVISION)
ALBUQUERQUE, BERNALILLO COUNTY, NEW MEXICO
JUNE, 2014

PROJECT NUMBER 1006864

APPLICATION NUMBER 14DRB-70215

UTILITY APPROVALS:

<i>[Signature]</i> QWEST CORPORATION d/b/a CENTURYLINK QC	DATE <u>8/27/14</u>
<i>[Signature]</i> COMCAST CABLE	DATE <u>8/27/14</u>
<i>[Signature]</i> PNM ELECTRIC SERVICES	DATE <u>8-26-14</u>
<i>[Signature]</i> NEW MEXICO GAS COMPANY	DATE <u>8/27/14</u>

CITY APPROVALS:

<i>[Signature]</i> CITY SURVEYOR	DATE <u>6-17-14</u>
<i>[Signature]</i> TRAFFIC ENGINEERING, TRANSPORTATION DIVISION	DATE <u>6/25/14</u>
<i>[Signature]</i> ALBUQUERQUE BERNALILLO COUNTY WATER UTILITY AUTHORITY	DATE <u>06/25/14</u>
<i>[Signature]</i> PARKS & RECREATION DEPARTMENT	DATE <u>6-25-14</u>
<i>[Signature]</i> CITY ENGINEER	DATE <u>6/27/14</u>
<i>[Signature]</i> DRB CHAIRPERSON, PLANNING DEPARTMENT	DATE <u>8-28-14</u>
<i>[Signature]</i> REAL PROPERTY DIVISION	DATE <u>9-4-14</u>
<i>[Signature]</i>	DATE <u>6-30-14</u>

TAX CERTIFICATION

THIS IS TO CERTIFY THAT TAXES ARE CURRENT AND PAID ON UPC #

100805942416140101 + 100805948123740104

PROPERTY OWNER OF RECORD Western Albuq. Land Holdings LLC
[Signature]
BERNALILLO COUNTY TREASURER'S OFFICE DATE 09-04-2014

SURVEYOR'S CERTIFICATION

I, Robert Gromatzky, a registered Professional New Mexico Surveyor, certify that I am responsible for this survey and that this plat was prepared by me or under my supervision, shows all existing easements as shown on the plats of record, or made known to me by the owner, utility companies, or other interested parties and conforms to the Minimum Requirements of the Board of Registration for Professional Engineers and Professional Surveyors and meets the minimum requirements for monumentation and surveys contained in the Albuquerque Subdivision Ordinance, and is true and accurate to the best of my knowledge and belief.

[Signature]
Robert Gromatzky
New Mexico Professional Surveyor 16469
Date: June 17, 2014



NOTES

- Bearings are New Mexico State Plane Grid Bearings (Central Zone) NAD 1927. Basis of Bearings is between City of Albuquerque Control Monuments "REWARD" and "BH 41". Bearing = N03°09'40"E
- Distances are ground distances.
- Record Bearings and distances are the same as shown on this plat and the same as shown on the Plat of Tracts N-2-A, N-2-B, N-2-C, N-2-D, N-2-E & N-2-F Watershed Subdivision filed on October 17, 2013 in Book 2013C, page 116 Document No. #2013115035.
- This Plat was prepared with information included in Title Commitment issued by First American Title Insurance Company, Commitment No. 1911525-AL04, Effective Date: March 6, 2014.
- Portions of Tracts N-2-A & N-2-F are located in Flood Zones "AO" and "X", per FIRM Map Number 35001C0307H, Revised August 16, 2012 and FIRM Map Number 35001C0326G, Revised August 16, 2012.
- SOLAR NOTE - Pursuant to Section 14-14-4-7 of the City of Albuquerque Code of Ordinances, "No property within the area of this Plat shall at any time be subject to a deed restriction, covenant, or binding agreement prohibiting solar collectors from being installed on buildings or erected on the lots or tracts within the area of proposed Plat. The foregoing requirement shall be a condition to approval of this plat."
- Tracts N-2-A-4, N-2-A-5, N-2-A-6, N-2-A-7, N-2-A-8, N-2-A-9, N-2-A-10, N-2-A-11, N-2-A-12, N-2-A-13, N-2-A-14, N-2-A-15, N-2-A-16, N-2-A-17, and N-2-F-1 are owned and maintained by the Del Webb HOA.
- Tract N-2-A-3 is a private commons area owned and maintained by the Del Webb HOA and is subject to a blanket private pedestrian and vehicular access easement for the benefit of the residence within the Del Webb community. Tract N-2-A-3 is subject to a blanket public subsurface sanitary sewer and water easement granted to ABCWUA with the filing of this plat. Tract N-2-A-3 is also subject to a blanket subsurface drainage easement granted to the City of Albuquerque with the filing of this plat. Easement is to be operated and maintained by the City of Albuquerque. Tract N-2-A-3 contains 11.9610 acres of land and is also granted as a Private Access Easement reserved for, granted to, and to be maintained by the Homeowners Association with the filing of this plat.
- The front (adjacent to street) lot corner will not be staked with the exception of intermediate "pc's and pt's". A witness corner projected along the property line being improvements. Offset distance will be adjusted by even foot increments to fall within the pan. Remaining lot corners will be marked with a 5/8" rebar and plastic cap stamped "Gromatzky PS 16469", a nail and washer stamped "Gromatzky PS 16469" or a nail and washer stamped "line only".
- Centerline monuments to be installed at centerline PC's, PT's, angle points and street intersections prior to acceptance of subdivision street improvements and will consist of a standard 3-1/4" aluminum alloy cap stamped "CITY OF ALBUQUERQUE", "CENTERLINE MONUMENTATION", "SURVEY MARKER", "DO NOT DISTURB", "PLS 16469".
- Tract N-2-A-1 is owned by the Del Webb HOA. Please refer to recorded easement agreement on this tract concerning maintenance responsibility within the existing arroyo. Any and all areas outside of said easement is maintained by the Del Webb HOA.
- Tract N-2-A-17 is subject to a blanket public subsurface water easement granted to ABCWUA with the filing of this plat. Tract N-2-A-17 is also subject to a blanket subsurface drainage easement granted to the city of Albuquerque with the filing of this plat.

SUBDIVISION DATA

- DRB No.
- Zone Atlas Index Number: H-8 & H-9.
- Zoning: SU-2 FOR PDA
- Gross Subdivision Acreage: 91.3678 Acres.
- Total number of Lots/Tracts Created: One hundred fifty-nine (159) Lots and twenty-two (22) Tracts.
- 0 miles public street right-of-way created.
- 1.808 miles private streets created.
- Area of private streets created: 11.9610 Acres (Tract N-2-A-3).
- Date of Survey: March, 2014.
- Plat is located within Town of Atrisco Grant, projected Sections 8 & 9, Township 10 North, Range 2 East, New Mexico Principal Meridian, City of Albuquerque, Bernalillo County, New Mexico.

PURPOSE OF PLAT

The purpose of this Plat is to subdivide all of Tracts N-2-A & N-2-F, Watershed Subdivision, Albuquerque, New Mexico as the same is shown and designated on the plat thereof, filed in the Office of the County Clerk of Bernalillo County, New Mexico on October 17, 2013 in Book 2013C page 116 as Document #2013115035 into 159 lots and 22 tracts, to vacate existing easements and to grant new easements.

PUBLIC UTILITY EASEMENTS

PUBLIC UTILITY EASEMENTS shown on this plat are granted for the common and joint use of:

- Public Service Company of New Mexico ("PNM"), a New Mexico corporation, (PNM Electric) for installation, maintenance, and service of overhead and underground electrical lines, transformers, and other equipment and related facilities reasonably necessary to provide electrical services.
- New Mexico Gas Company for installation, maintenance, and service of natural gas lines, valves and other equipment and facilities reasonably necessary to provide natural gas.
- Qwest for the installation, maintenance, and service of such lines, cable, and other related equipment and facilities reasonably necessary to provide communication services.
- Cable TV for the installation, maintenance, and service of such lines, cable, and other related equipment and facilities reasonably necessary to provide Cable services.

Included, is the right to build, rebuild, construct, reconstruct, locate, relocate, change, remove, replace, modify, renew, operate and maintain facilities for purposes described above, together with free access to, from, and over said easements, with the right and privilege of going upon, over and across adjoining lands of Grantor for the purposes set forth herein and with the right to utilize the right of way and easement to extend services to customers of Grantee, including sufficient working area space for electric transformers, with the right and privilege to trim and remove trees, shrubs or bushes which interfere with the purposes set forth herein. No building, sign, pool (above ground or subsurface), hot tub, concrete or wood pool decking, or other structure shall be erected or constructed on said easements, nor shall any well be drilled or operated thereon. Property owners shall be solely responsible for correcting any violations of National Electrical Safety Code by construction of pools, decking, or any structures adjacent to or near easements shown on this plat. PNM, NM Gas Company, CenturyLink (Qwest) and Comcast shall have the right to cross said private streets (Tract N-2-A-3) at locations as mutually agreed upon by the Owner and said named public utility company. Easements for electric transformer/switchgears, as installed, shall extend ten (10) feet in front of transformer/switchgear doors and five (5) feet on each side.

Disclaimer
In approving this plat, Public Service Company of New Mexico (PNM) and New Mexico Gas Company (NMGC) did not conduct a Title Search of the properties shown hereon. Consequently, PNM and NMGC do not waive or release any easement or easement rights which may have been granted by prior plat, replat or other document and which are not shown on this plat.

DOC# 2014070165

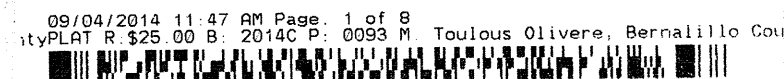

PLAT OF DEL WEBB @ MIREHAVEN PHASE I

(A REPLAT OF TRACTS N-2-A & N-2-F WATERSHED SUBDIVISION)
ALBUQUERQUE, BERNALILLO COUNTY, NEW MEXICO
JUNE, 2014

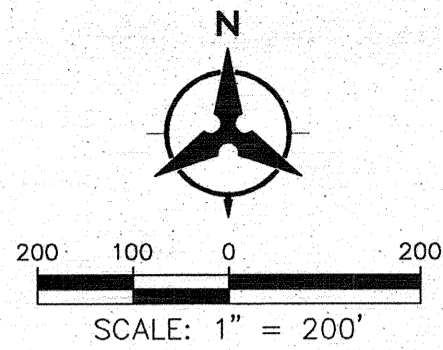

NOTE: SEE SHEETS 3-8 FOR SUBDIVISION
DETAILS

ACS BRASS TABLE "BH_41"
GEOGRAPHIC POSITION (NAD 1983)
NM STATE PLANE COORDINATES (CENTRAL ZONE)
N=1,496,608.828 E=1,491,701.376
GROUND TO GRID FACTOR = 0.999670930
DELTA ALPHA = -0°17'09.70"

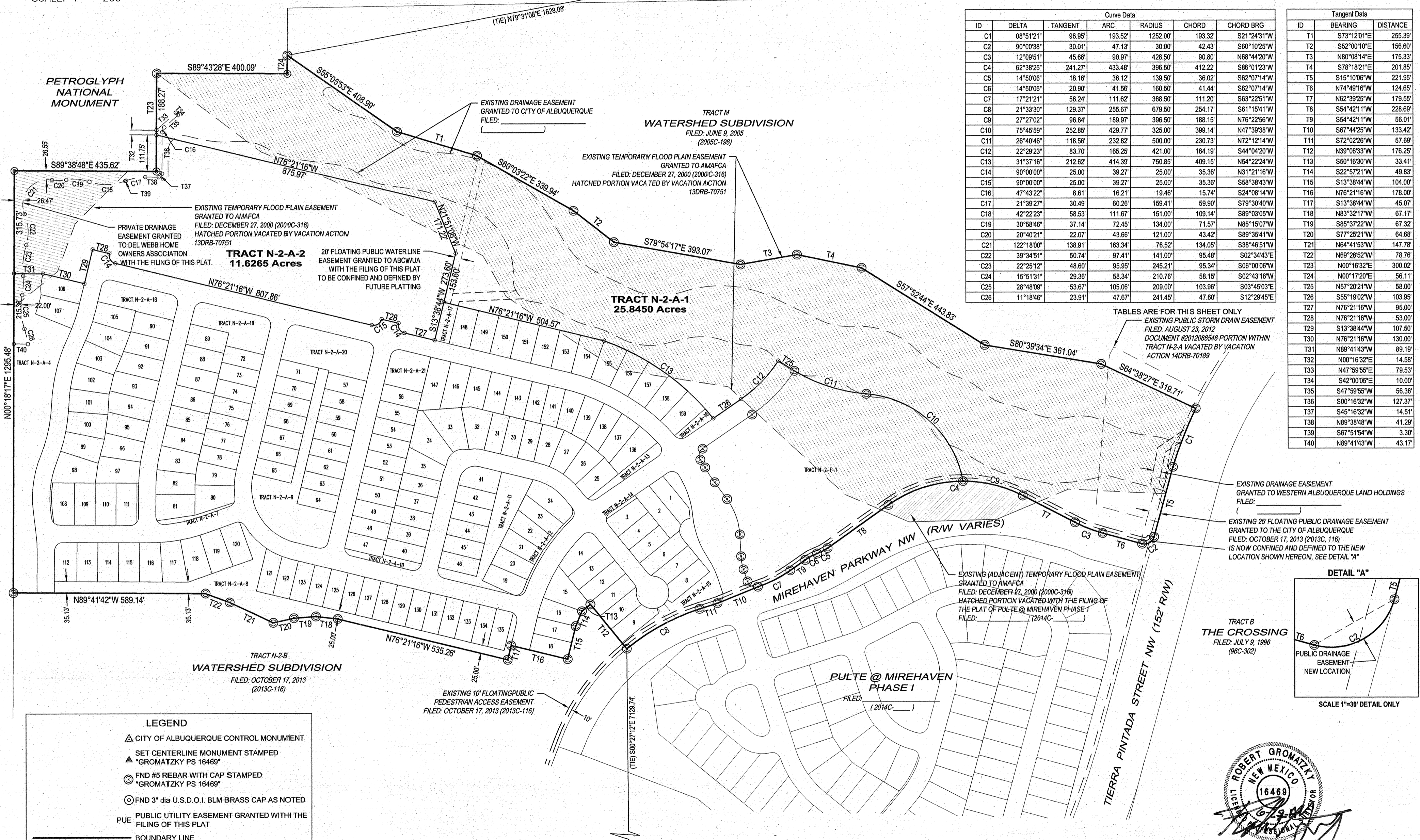

Curve Data							Tangent Data		
ID	DELTA	TANGENT	ARC	RADIUS	CHORD	CHORD BRG	ID	BEARING	DISTANCE
C1	08°51'21"	96.95'	193.52'	1252.00'	193.32'	S21°24'31"W	T1	S73°12'01"E	255.39'
C2	90°00'38"	30.01'	47.13'	30.00'	42.43'	S60°10'25"W	T2	S52°00'10"E	156.60'
C3	12°08'51"	45.66'	90.97'	428.50'	90.80'	N68°44'20"W	T3	N80°08'14"E	175.33'
C4	62°38'25"	241.27'	433.48'	396.50'	412.22'	S86°01'23"W	T4	S78°18'21"E	201.85'
C5	14°50'06"	18.16'	36.12'	139.50'	36.02'	S62°07'14"W	T5	S15°10'06"W	221.95'
C6	14°50'06"	20.90'	41.56'	160.50'	41.44'	S62°07'14"W	T6	N74°49'16"W	124.65'
C7	17°21'21"	56.24'	111.62'	368.50'	111.20'	S63°22'51"W	T7	N62°39'25"W	179.55'
C8	21°33'30"	129.37'	256.67'	679.50'	254.17'	S61°15'41"W	T8	S54°42'11"W	228.69'
C9	27°27'02"	96.84'	189.97'	396.50'	188.15'	N76°22'56"W	T9	S54°42'11"W	56.01'
C10	75°45'59"	252.85'	429.77'	325.00'	399.14'	N47°39'38"W	T10	S67°44'25"W	133.42'
C11	26°40'46"	118.56'	232.82'	500.00'	230.73'	N72°12'14"W	T11	S72°02'26"W	57.69'
C12	22°29'23"	83.70'	165.25'	421.00'	164.19'	S44°04'20"W	T12	N39°06'33"W	176.25'
C13	31°37'16"	129.37'	256.67'	679.50'	254.17'	S61°15'41"W	T13	S50°16'30"W	33.41'
C14	90°00'00"	25.00'	39.27'	25.00'	35.36'	N31°21'16"W	T14	S22°57'21"W	49.83'
C15	90°00'00"	25.00'	39.27'	25.00'	35.36'	S68°38'43"W	T15	S13°38'44"W	104.00'
C16	47°43'22"	8.61'	16.21'	19.46'	15.74'	S24°08'14"W	T16	N76°21'16"W	178.00'
C17	21°39'27"	30.49'	60.26'	159.41'	59.90'	S78°30'40"W	T17	S13°38'44"W	45.07'
C18	42°22'23"	58.53'	111.67'	151.00'	109.14'	S89°03'05"W	T18	N83°32'17"W	67.17'
C19	30°58'46"	37.14'	72.45'	134.00'	71.57'	N85°15'07"W	T19	S85°37'22"W	67.32'
C20	20°40'21"	22.07'	43.66'	121.00'	43.42'	S89°35'41"W	T20	S77°25'21"W	64.66'
C21	122°18'00"	138.91'	163.34'	76.52'	134.05'	S38°46'51"W	T21	N64°41'53"W	147.78'
C22	39°34'51"	50.74'	97.41'	141.00'	95.48'	S02°34'43"E	T22	N69°28'52"W	78.76'
C23	22°25'12"	48.60'	95.95'	245.21'	95.34'	S06°00'06"W	T23	N00°16'32"E	300.02'
C24	15°51'31"	29.36'	58.34'	210.76'	58.15'	S02°43'16"W	T24	N00°17'20"E	56.11'
C25	28°48'09"	53.67'	105.06'	209.00'	103.96'	S03°45'03"E	T25	N57°20'21"W	58.00'
C26	11°18'46"	23.91'	47.67'	241.45'	47.60'	S12°29'45"E	T26	S55°19'02"W	103.95'
							T27	N76°21'16"W	95.00'
							T28	N76°21'16"W	53.00'
							T29	S13°38'44"W	107.50'
							T30	N76°21'16"W	130.00'
							T31	N89°41'43"W	89.19'
							T32	N00°16'32"E	14.58'
							T33	N47°59'55"E	79.53'
							T34	S42°00'05"E	10.00'
							T35	S47°59'55"W	56.36'
							T36	S00°16'32"W	127.37'
							T37	S45°16'32"W	14.51'
							T38	N89°38'48"W	41.29'
							T39	S67°51'54"W	3.30'
							T40	N89°41'43"W	43.17'

TABLES ARE FOR THIS SHEET ONLY
EXISTING PUBLIC STORM DRAIN EASEMENT
FILED: AUGUST 23, 2012
DOCUMENT #2012086548 PORTION WITHIN
TRACT N-2-A VACATED BY VACATION
ACTION 14DRB-70189

ID	BEARING	DISTANCE
T1	S73°12'01"E	255.39'
T2	S52°00'10"E	156.60'
T3	N80°08'14"E	175.33'
T4	S78°18'21"E	201.85'
T5	S15°10'06"W	221.95'
T6	N74°49'16"W	124.65'
T7	N62°39'25"W	179.55'
T8	S54°42'11"W	228.69'
T9	S54°42'11"W	56.01'
T10	S67°44'25"W	133.42'
T11	S72°02'26"W	57.69'
T12	N39°06'33"W	176.25'
T13	S50°16'30"W	33.41'
T14	S22°57'21"W	49.83'
T15	S13°38'44"W	104.00'
T16	N76°21'16"W	178.00'
T17	S13°38'44"W	45.07'
T18	N83°32'17"W	67.17'
T19	S85°37'22"W	67.32'
T20	S77°25'21"W	64.66'
T21	N64°41'53"W	147.78'
T22	N69°28'52"W	78.76'
T23	N00°16'32"E	300.02'
T24	N00°17'20"E	56.11'
T25	N57°20'21"W	58.00'
T26	S55°19'02"W	103.95'
T27	N76°21'16"W	95.00'
T28	N76°21'16"W	53.00'
T29	S13°38'44"W	107.50'
T30	N76°21'16"W	130.00'
T31	N89°41'43"W	89.19'
T32	N00°16'32"E	14.58'
T33	N47°59'55"E	79.53'
T34	S42°00'05"E	10.00'
T35	S47°59'55"W	56.36'
T36	S00°16'32"W	127.37'
T37	S45°16'32"W	14.51'
T38	N89°38'48"W	41.29'
T39	S67°51'54"W	3.30'
T40	N89°41'43"W	43.17'

EXISTING DRAINAGE EASEMENT
GRANTED TO WESTERN ALBUQUERQUE LAND HOLDINGS
FILED: _____

EXISTING 25' FLOATING PUBLIC DRAINAGE EASEMENT
GRANTED TO THE CITY OF ALBUQUERQUE
FILED: OCTOBER 17, 2013 (2013C, 116)
IS NOW CONFINED AND DEFINED TO THE NEW
LOCATION SHOWN HEREON. SEE DETAIL "A"

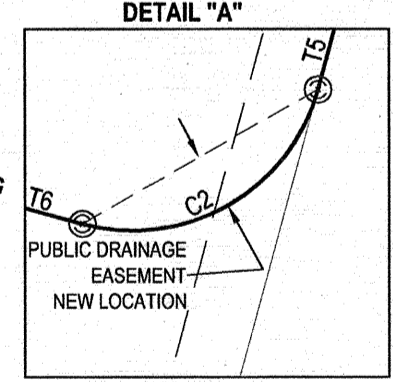

TRACT B
THE CROSSING
FILED: JULY 9, 1996
(96C-302)

LEGEND

- ▲ CITY OF ALBUQUERQUE CONTROL MONUMENT
- ▲ SET CENTERLINE MONUMENT STAMPED "GROMATZKY PS 16469"
- ⊙ FND #5 REBAR WITH CAP STAMPED "GROMATZKY PS 16469"
- ⊙ FND 3" dia U.S.D.O.I. BLM BRASS CAP AS NOTED
- PUE PUBLIC UTILITY EASEMENT GRANTED WITH THE FILING OF THIS PLAT
- BOUNDARY LINE
- LOT LINE
- - - EXISTING EASEMENT LINE
- - - PROPOSED EASEMENT LINE
- ADJOINING PROPERTY LINE

ACS BRASS TABLE "REWARD 1969"
GEOGRAPHIC POSITION (NAD 1983)
NM STATE PLANE COORDINATES (CENTRAL ZONE)
N=1,487,364.063 E=1,491,190.819
GROUND TO GRID FACTOR = 0.999675005
DELTA ALPHA = -0°17'12.26"
NAVD 1988 ELEVATION = 5319.688

DOCH 2014070165
09/04/2014 11:47 AM Page: 2 of 8
11/11/2014 8:52:00 P. 2014C.P. 0083 M. Toulouse Olivere, Bernalillo Cou

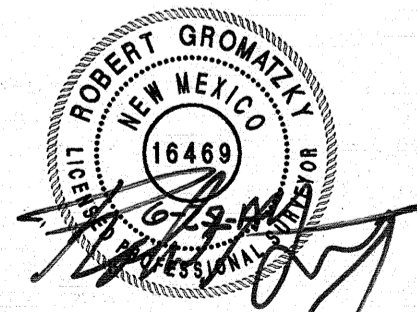

Bohannon & Huston
Court yard I 7500 Jefferson St. NE
Albuquerque, NM 87109 (505) 823-1000

P:\20130375\SURVEY\DEL WEBB Mirehaven Phase I\Graphics\20130375 Del Webb Mirehaven I Plat.dwg
Wed, 25-Jun-2014 - 2:47:pm, Plotted by: RGROMATZKY

**PLAT OF
DEL WEBB @ MIREHAVEN
PHASE I**
(A REPLAT OF TRACTS N-2-A & N-2-F WATERSHED SUBDIVISION)
ALBUQUERQUE, BERNALILLO COUNTY, NEW MEXICO
JUNE, 2014

LEGEND

- ▲ SET CENTERLINE MONUMENT STAMPED "GROMATZKY PS 16469"
- ⊙ FND #5 REBAR WITH CAP STAMPED "GROMATZKY PS 16469"
- PUE PUBLIC UTILITY EASEMENT GRANTED WITH THE FILING OF THIS PLAT
- BOUNDARY LINE
- LOT LINE
- - - EXISTING EASEMENT LINE
- - - PROPOSED EASEMENT LINE
- ADJOINING PROPERTY LINE

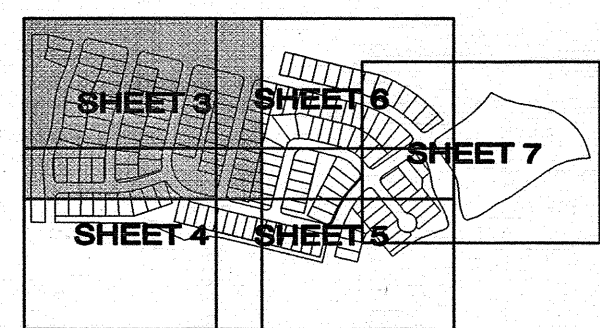
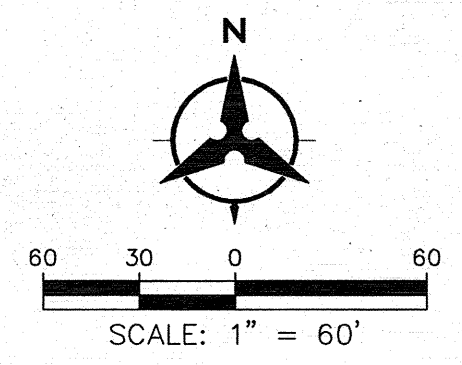

Bohannon & Huston
 Courtyard I 7500 Jefferson St. NE
 Albuquerque, NM 87109 (505) 823-1000

**PLAT OF
DEL WEBB @ MIREHAVEN
PHASE I**
(A REPLAT OF TRACTS N-2-A & N-2-F WATERSHED SUBDIVISION)
ALBUQUERQUE, BERNALILLO COUNTY, NEW MEXICO
JUNE, 2014

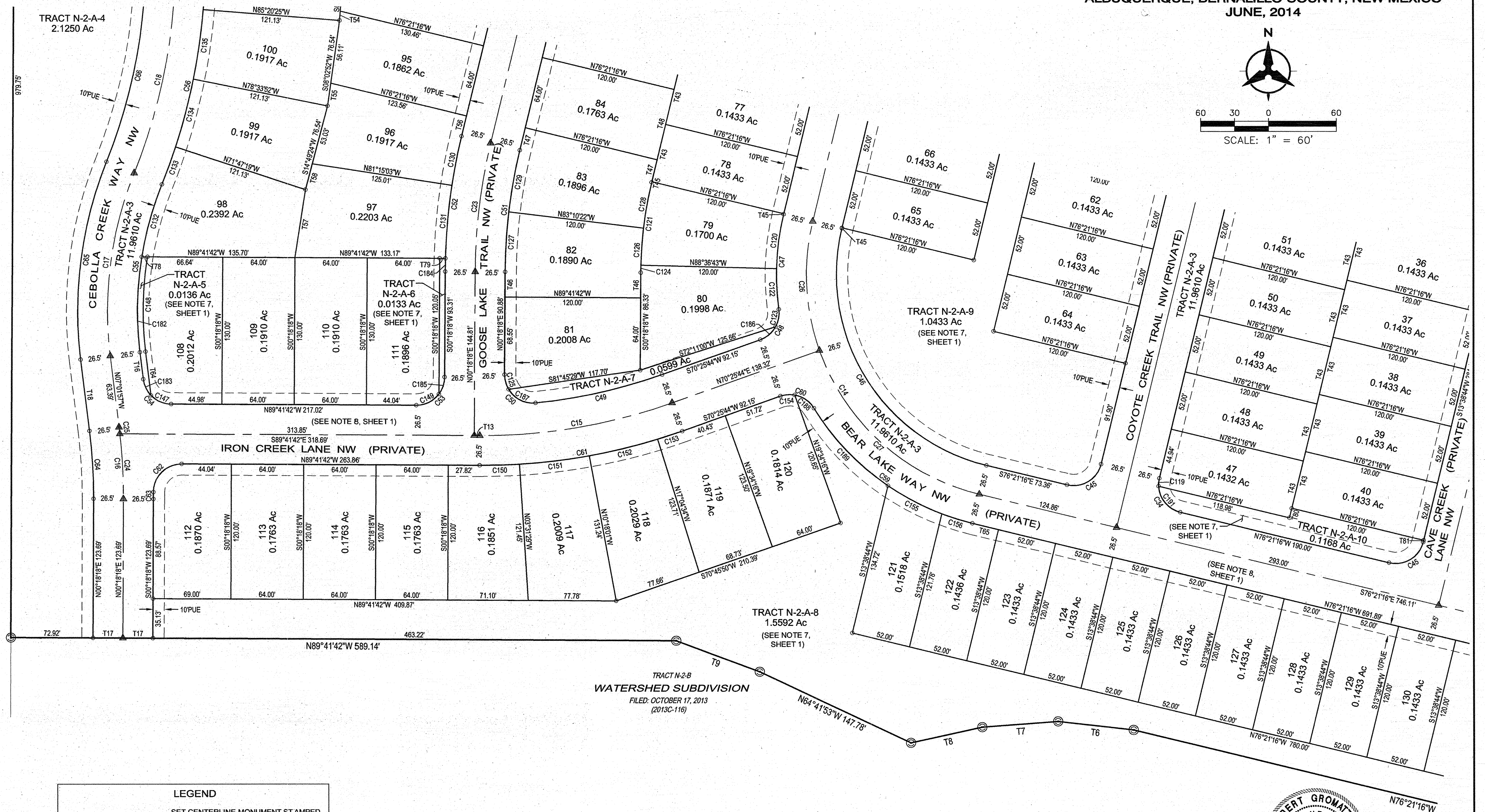
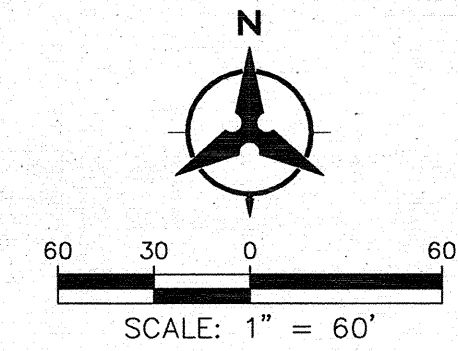

TRACT N-2-B
WATERSHED SUBDIVISION
FILED: OCTOBER 17, 2013
(2013C-116)

- LEGEND**
- SET CENTERLINE MONUMENT STAMPED
"GROMATZKY PS 16469"
 - FND #5 REBAR WITH CAP STAMPED
"GROMATZKY PS 16469"
 - PUE PUBLIC UTILITY EASEMENT GRANTED
WITH THE FILING OF THIS PLAT
 - BOUNDARY LINE
 - LOT LINE
 - EXISTING EASEMENT LINE
 - PROPOSED EASEMENT LINE
 - ADJOINING PROPERTY LINE

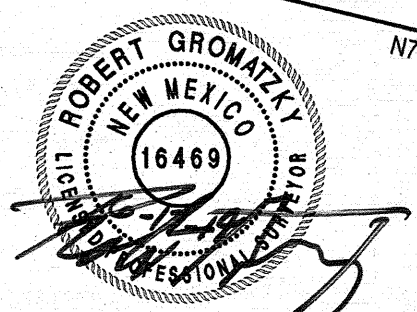
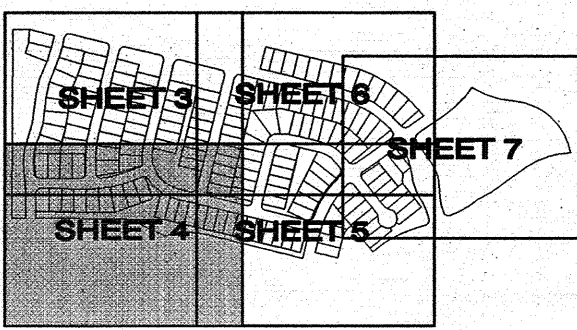

Bohannon & Huston

Courtyard I 7500 Jefferson St. NE
Albuquerque, NM 87109 (505) 823-1000

PLAT OF DEL WEBB @ MIREHAVEN PHASE I

(A REPLAT OF TRACTS N-2-A & N-2-F WATERSHED SUBDIVISION)
ALBUQUERQUE, BERNALILLO COUNTY, NEW MEXICO
JUNE, 2014

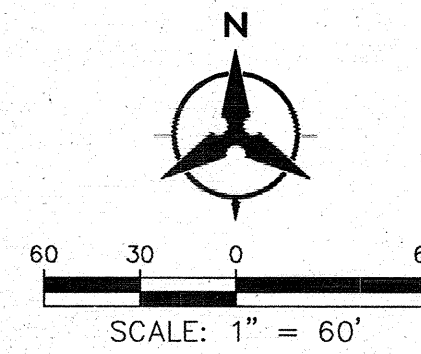

LEGEND	
	SET CENTERLINE MONUMENT STAMPED "GROMATZKY PS 16469"
	FND #5 REBAR WITH CAP STAMPED "GROMATZKY PS 16469"
	PUE PUBLIC UTILITY EASEMENT GRANTED WITH THE FILING OF THIS PLAT
	BOUNDARY LINE
	LOT LINE
	EXISTING EASEMENT LINE
	PROPOSED EASEMENT LINE
	ADJOINING PROPERTY LINE

SEE SHEET 8 FOR CURVE AND TANGENT TABLES

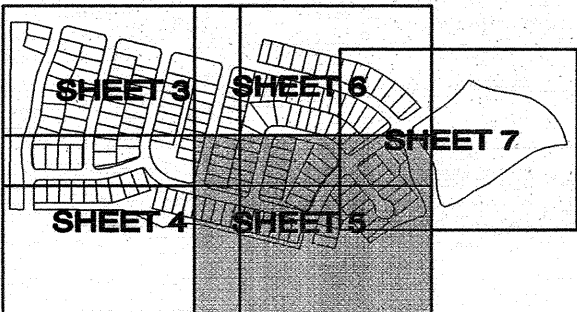
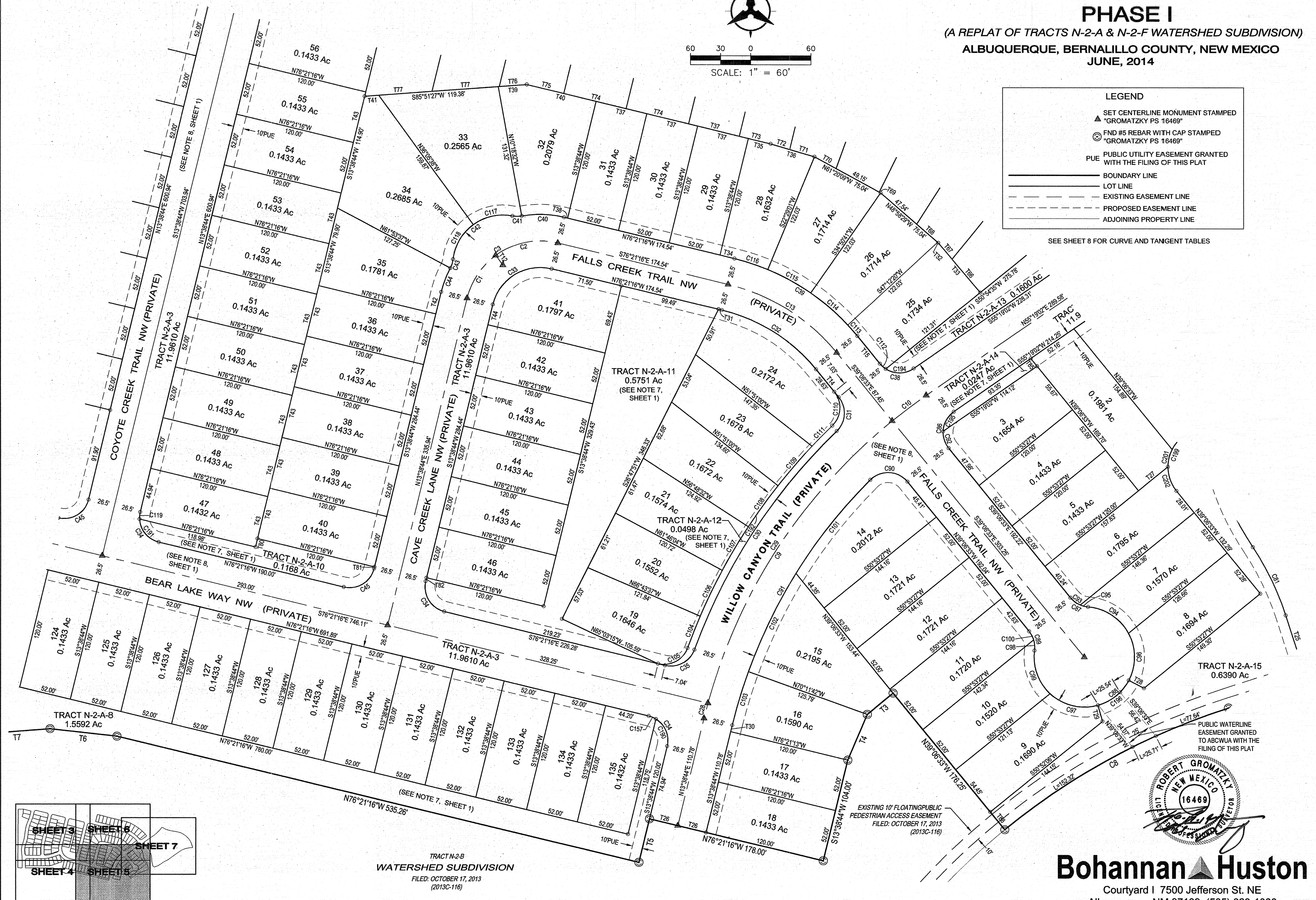

TRACT N-2-B
WATERSHED SUBDIVISION
FILED: OCTOBER 17, 2013
(2013C-116)

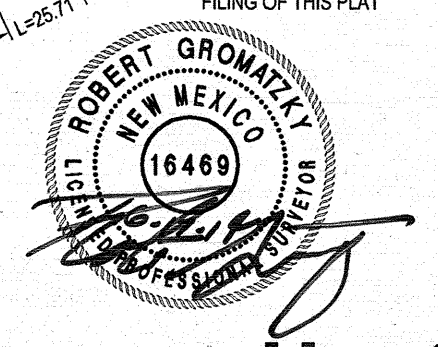

Bohannon & Huston

Courtyard I 7500 Jefferson St. NE
Albuquerque, NM 87109 (505) 823-1000

PLAT OF
DEL WEBB @ MIREHAVEN
PHASE I

(A REPLAT OF TRACTS N-2-A & N-2-F WATERSHED SUBDIVISION)
 ALBUQUERQUE, BERNALILLO COUNTY, NEW MEXICO
 JUNE, 2014

LEGEND

- ▲ SET CENTERLINE MONUMENT STAMPED "GROMATZKY PS 16469"
- ⊙ FND #5 REBAR WITH CAP STAMPED "GROMATZKY PS 16469"
- PUE PUBLIC UTILITY EASEMENT GRANTED WITH THE FILING OF THIS PLAT
- BOUNDARY LINE
- LOT LINE
- - - EXISTING EASEMENT LINE
- - - PROPOSED EASEMENT LINE
- ADJOINING PROPERTY LINE

SEE SHEET 6 FOR CURVE AND TANGENT TABLES

EXISTING PUBLIC DRAINAGE EASEMENT GRANTED TO THE CITY OF ALBUQUERQUE
 FILED:
 DOCUMENT # _____

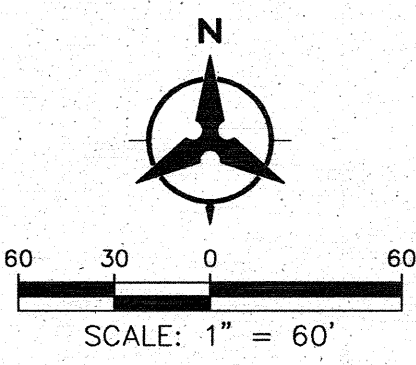
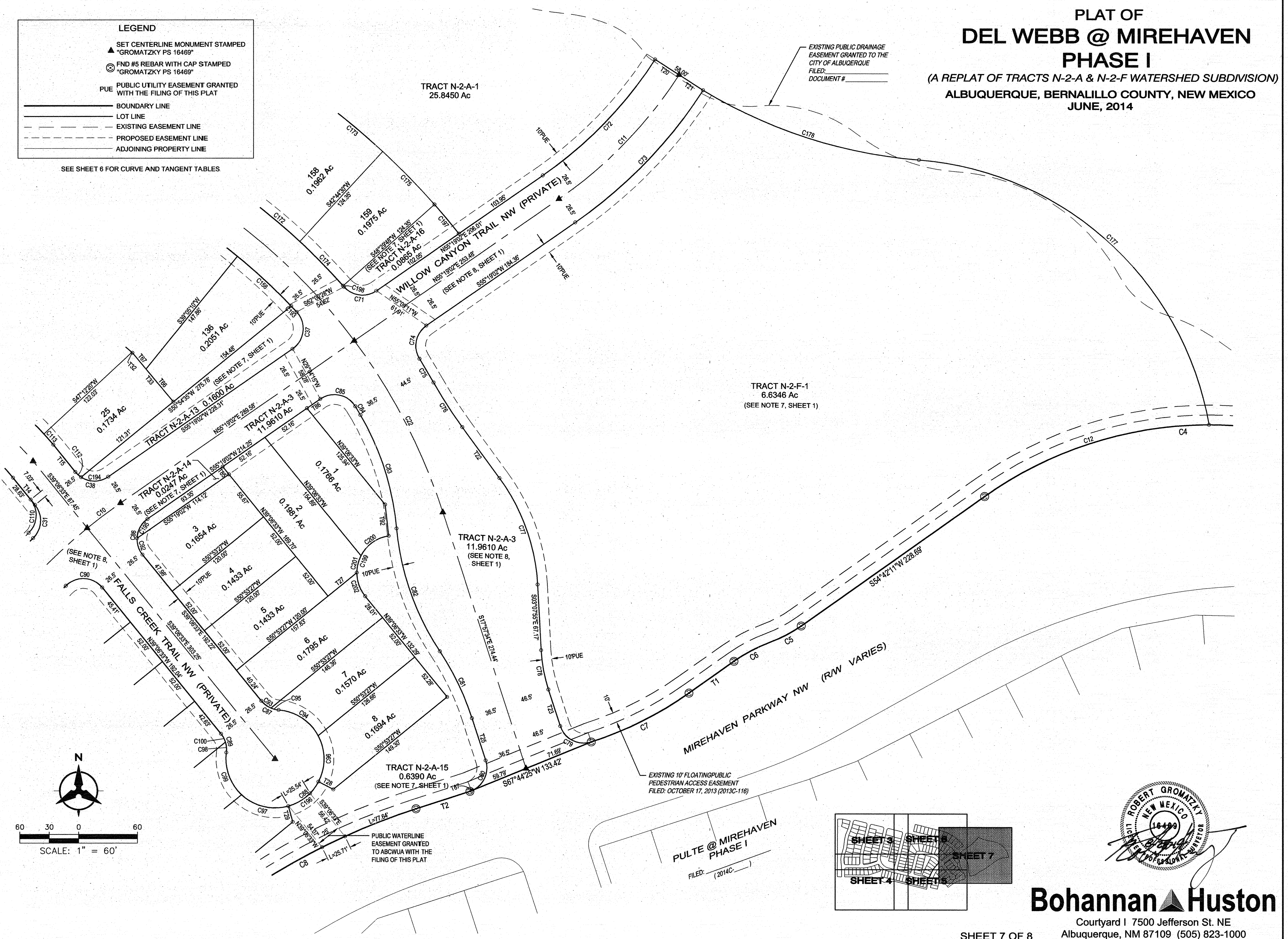

Bohannon & Huston

Courtyard | 7500 Jefferson St. NE
 Albuquerque, NM 87109 (505) 823-1000

SHEET 7 OF 8

**PLAT OF
DEL WEBB @ MIREHAVEN
PHASE I**
(A REPLAT OF TRACTS N-2-A & N-2-F WATERSHED SUBDIVISION)
ALBUQUERQUE, BERNALILLO COUNTY, NEW MEXICO
JUNE, 2014

Curve Data						
ID	DELTA	TANGENT	ARC	RADIUS	CHORD	CHORD BRG
C1	40°14'53"	27.48	52.68	75.00	63.10	N33°46'10"E
C2	49°45'07"	34.78	65.13	75.00	63.10	N78°46'10"E
C3	90°00'00"	75.00	117.81	75.00	106.07	N58°38'44"E
C4	62°38'25"	241.27	433.48	396.50	412.22	S86°01'23"W
C5	14°50'06"	18.16	36.12	139.50	36.02	S62°07'14"W
C6	14°50'06"	20.90	41.56	160.50	41.44	S62°07'14"W
C7	17°21'21"	56.24	111.62	368.50	111.20	S63°22'51"W
C8	21°33'30"	129.37	255.67	679.50	254.17	S61°15'41"W
C9	37°14'43"	185.34	357.53	550.00	351.27	N32°16'05"E
C10	04°25'35"	21.26	42.49	550.00	42.48	N53°06'14"E
C11	22°29'47"	89.50	176.69	450.00	175.55	N44°04'08"E
C12	35°11'22"	125.74	243.52	396.50	239.71	S72°17'52"W
C13	37°14'43"	67.40	130.01	200.00	127.73	S57°43'55"E
C14	90°00'00"	200.00	314.16	200.00	282.84	S31°21'16"E
C15	19°52'34"	87.61	173.45	500.00	172.58	N80°22'01"E
C16	07°20'16"	32.06	64.03	500.00	63.99	N03°21'50"W
C17	29°04'22"	84.27	164.91	325.00	163.15	N07°30'14"E
C18	19°39'20"	86.61	171.53	500.00	170.69	N12°12'45"E
C19	22°58'11"	101.59	200.45	500.00	199.11	N13°52'10"E
C20	11°42'32"	51.27	102.18	500.00	102.00	N19°30'00"E
C21	39°35'19"	215.95	414.57	600.00	406.37	S56°33'36"E
C22	18°48'22"	99.36	196.94	600.00	196.06	S27°21'46"E
C23	13°20'33"	57.66	114.81	493.00	114.55	N06°58'35"E
C24	06°39'13"	29.07	58.06	500.00	58.03	N03°01'18"W
C25	00°41'02"	2.98	5.97	500.00	5.97	N06°41'26"W
C26	33°13'00"	59.65	119.35	200.00	114.33	S02°57'46"E
C27	56°47'00"	108.10	196.21	200.00	190.20	S47°57'46"E
C28	01°37'53"	7.83	15.66	550.00	15.66	N14°27'40"E
C29	35°36'50"	176.66	341.87	550.00	336.39	N33°05'02"E
C30	25°58'13"	133.51	262.44	579.00	260.20	N33°00'52"E
C31	85°06'31"	22.95	37.14	25.00	33.81	N03°26'43"E
C32	37°14'43"	58.47	112.78	173.50	110.81	N57°43'55"W
C33	90°00'00"	46.50	76.18	48.50	68.59	S58°38'44"W
C34	90°00'00"	25.00	39.27	25.00	35.36	S31°21'16"E
C35	83°36'58"	22.36	36.48	25.00	33.33	N61°50'15"E
C36	33°43'39"	173.85	337.59	573.50	332.74	S59°29'27"E
C37	97°56'39"	28.73	42.74	25.00	37.72	S06°20'42"W
C38	85°34'25"	23.14	37.34	25.00	33.96	N81°53'46"W
C39	37°14'43"	76.33	147.24	226.50	144.66	N57°43'55"W
C40	23°57'15"	21.53	42.44	101.50	42.13	N88°19'54"W
C41	21°28'18"	4.74	9.37	25.00	9.31	N89°39'08"W
C42	94°22'48"	53.98	82.36	50.00	73.36	S53°53'37"W
C43	21°24'29"	4.73	9.34	25.00	9.29	S17°24'27"W
C44	14°27'58"	12.88	25.63	101.50	25.56	S20°52'43"W
C45	90°00'00"	25.00	39.27	25.00	35.36	S58°38'44"W
C46	90°00'00"	173.50	272.53	173.50	245.37	S31°21'16"E
C47	21°24'02"	42.80	84.60	226.50	84.11	S02°56'43"W
C48	78°11'02"	20.31	34.11	25.00	31.53	S31°20'13"W
C49	13°54'17"	57.74	114.91	473.50	114.63	S77°22'52"W
C50	95°58'17"	27.75	41.88	25.00	37.15	N47°40'50"W
C51	13°20'26"	54.56	108.62	466.50	108.37	N06°58'31"E
C52	13°20'26"	60.75	120.96	519.50	120.68	S06°58'31"W
C53	90°00'00"	25.00	39.27	25.00	35.36	S45°18'18"W
C54	82°39'44"	21.99	36.07	25.00	33.02	N48°21'50"W
C55	29°04'22"	77.40	151.46	298.50	149.84	N07°30'14"E
C56	19°39'20"	91.21	180.62	526.50	179.73	N12°12'45"E
C57	22°58'11"	96.20	189.83	473.50	188.56	N13°52'10"E
C58	11°42'32"	53.99	107.59	526.50	107.41	N19°30'00"E
C59	44°58'02"	93.74	177.76	226.50	173.24	N53°52'15"W
C60	78°11'02"	20.31	34.11	25.00	31.53	N70°28'45"W
C61	19°52'34"	92.25	182.65	526.50	181.73	S80°22'01"W
C62	90°40'07"	25.29	39.56	25.00	35.56	S44°58'15"W
C63	00°40'07"	3.07	6.14	526.50	6.14	S00°01'45"E
C64	07°20'16"	30.36	60.64	473.50	60.60	N03°21'50"W
C65	29°04'22"	91.14	178.38	351.50	176.45	N07°30'14"E
C66	19°39'20"	82.02	162.44	473.50	161.84	N12°12'45"E
C67	22°58'11"	106.97	211.07	526.50	209.66	N13°52'10"E
C68	11°42'32"	48.55	96.76	473.50	96.60	N19°30'00"E
C69	90°00'00"	25.00	39.27	25.00	35.36	N58°38'43"E
C70	34°59'23"	197.47	382.59	626.50	376.68	S58°51'35"E
C71	83°19'05"	22.24	36.35	25.00	33.23	S83°01'28"E
C72	22°29'23"	83.70	165.25	421.00	164.19	N44°04'20"E
C73	22°30'36"	95.32	188.19	479.00	186.98	S44°03'44"W
C74	87°14'38"	23.83	38.07	25.00	34.49	S11°41'43"W
C75	02°29'38"	14.03	28.05	644.50	28.05	S30°40'47"E
C76	06°46'13"	27.06	54.08	457.50	54.03	S32°49'04"E
C77	33°04'15"	59.97	116.59	202.00	114.98	S19°40'03"E
C78	14°49'39"	20.49	40.76	157.50	40.65	S10°32'45"E
C79	89°58'54"	24.99	39.26	25.00	35.35	S62°57'01"E
C80	85°42'00"	23.19	37.39	25.00	34.00	N24°53'25"E
C81	15°33'15"	38.04	75.60	278.50	75.37	N25°44'12"W
C82	28°20'43"	68.56	134.32	271.50	132.95	N19°20'28"W
C83	25°02'42"	61.86	121.74	278.50	120.77	N17°41'27"W
C84	01°02'32"	5.12	10.25	563.50	10.25	N30°44'04"W
C85	93°25'38"	26.54	40.77	25.00	36.40	N77°56'09"W
C86	94°25'35"	27.01	41.20	25.00	36.69	S08°06'14"W
C87	46°37'59"	10.78	20.35	25.00	19.79	S62°25'33"E
C88	273°15'59"	---	238.47	50.00	68.67	S50°53'27"W
C89	46°37'59"	10.78	20.35	25.00	19.79	N15°47'33"W
C90	95°57'35"	27.75	41.87	25.00	37.15	N87°05'21"W

Curve Data						
ID	DELTA	TANGENT	ARC	RADIUS	CHORD	CHORD BRG
C91	31°17'08"	145.88	284.48	521.00	280.96	S29°17'18"W
C92	41°17'47"	9.42	18.02	25.00	17.63	N18°27'40"W
C93	28°03'54"	6.25	12.25	25.00	12.12	N53°08'30"W
C94	57°16'53"	27.31	49.99	50.00	47.93	N19°06'06"W
C95	18°34'05"	4.09	8.10	25.00	8.07	N76°27'30"W
C96	56°01'20"	26.60	48.89	50.00	46.96	N00°27'00"W
C97	58°43'21"	28.13	51.24	50.00	49.03	S76°20'14"E
C98	24°37'49"	5.46	10.75	25.00	10.66	S04°47'28"E
C99	54°30'00"	25.75	47.56	50.00	45.79	S19°43'33"E
C100	22°00'11"	4.86	9.60	25.00	9.54	S28°06'28"E
C101	13°09'40"	60.10	119.68	521.00	119.41	N38°21'02"E
C102	11°57'57"	54.60	108.81	521.00	108.61	N25°47'14"E
C103	06°09'32"	28.03	56.00	521.00	55.98	N16°43'30"E
C104	03°19'02"	16.97	33.93	566.00	33.92	S21°36'52"W
C105	83°41'22"	22.39	36.52	25.00	33.36	S61°48'03"W
C106	04°57'32"	25.37	50.72	566.00	50.70	S25°45'10"W
C107	04°57'32"	25.37	50.72	566.00	50.70	S30°42'42"W
C108	04°57'32"	25.37	50.72	566.00	50.70	S35°40'14"W
C109	05°05'27"	26.05	52.07	566.00	52.05	S40°41'44"W
C110	85°09'54"	22.97	37.16	25.00	33.83	S03°28'24"W
C111	02°48'53"	14.40	28.79	566.00	28.79	S44°38'54"W
C112	18°04'02"	3.97	7.88	25.00	7.85	N48°08'34"W
C113	03°41'07"	7.29	14.57	226.50	14.57	N40°57'06"W
C114	12°21'39"	24.53	48.86	226.50	48.77	N48°58'29"W
C115	12°21'39"	24.53	48.86	226.50	48.77	N61°20'09"W
C116	08°50'18"	17.50	34.94	226.50	34.94	N71°56'07"W
C117	47°10'39"	21.83	41.17	50.00	40.02	S77°29'41"W
C118	47°12'09"	21.85	41.19	50.00	40.04	S30°18'17"W
C119	16°24'42"	3.61	7.16	25.00	7.14	N05°26'23"E
C120	12°15'26"	24.32	48.46	226.50	48.36	S07°31'01"W
C121	12°15'26"	37.21	74.13	346.50	73.99	N07°31'01"W
C122	09°08'36"	18.11	36.14	226.50	36.11	S03°11'00"E
C123	36°41'11"	8.29	16.01	25.00	15.74	S10°35'17"W
C124	01°04'59"	3.28	6.55	346.50	6.55	N00°50'48"E
C125	31°10'34"	6.97	13.60	25.00	13.44	N15°16'59"W
C126	06°31'20"	19.74	39.44	346.50	39.42	S03°33'58"W
C127	06°31'20"	26.58	53.10	466.50	53.07	N03°33'58"E
C128	06°49'06"	20.64	41.23	346.50	41.21	S10°14'11"W
C129	06°49'06"	27.79	55.51	466.50	55.48	N10°14'11"E
C130	04°53'47"	22.21	44.39	519.50	44.38	S11°11'51"W
C131	07°09'17"	32.48	64.87	519.50	64.83	S05°10'19"W
C132	12°49'53"	33.57	66.85	298.50	66.71	N15°37'28"E
C133	03°49'44"	17.60	35.18	526.50	35.18	N10°07'33"E
C134	06°46'33"	31.17	62.26	526.50	62.23	N14°49'24"E
C135	06°46'33"	31.17	62.26	526.50	62.23	N08°02'52"E
C136	02°16'31"	10.45	20.91	526.50	20.91	N03°31'20"E
C137	06°02'11"	24.97	49.89	473.50	49.86	N05°24'10"E
C138	09°49'47"	40.72	81.23	473.50	81.14	N13°20'09"E
C139	07°06'13"	29.39	58.71	473.50	58.67	N21°48'09"E
C140	01°19'28"	6.09	12.17	526.50	12.17	N24°41'32"E
C141	06°46'33"	31.17	62.26	526.50	62.23	N20°38'31"E
C142	03°36'31"	16.59	33.16	526.50	33.15	N15°26'59"E
C143	06°46'38"	1.66	3.31	28.00	3.31	N02°04'02"W
C144	19°06'05"	24.55	48.64	145.89	48.41	N04°05'41"E
C145	08°25'13"	34.86	69.59	473.50	69.52	S17°51'20"W
C146	15°53'01"	3.91	7.76	28.00	7.74	N09°15'47"E
C147	45°47'33"	10.56	19.98	25.00	19.45	N66°47'55"W
C148	16°23'40"	42.28	83.98	293.50	83.69	N01°09'52"E
C149	52°59'21"	12.46	23.12	25.00	23.31	S63°48'38"W
C150	03°49'47"	17.6				



OFFICIAL NOTICE OF DECISION

CITY OF ALBUQUERQUE
PLANNING DEPARTMENT
DEVELOPMENT REVIEW BOARD

February 12, 2014

Project# 1006864

13DRB-70808 - PRELIMINARY PLAT
13DRB-70809 - SIDEWALK VARIANCE
13DRB-70810 - SIDEWALK WAIVER
13DRB-70811 - SUBDIVISION DESIGN VARIANCE/ MIN DPM STANDARDS
14DRB-70010 - EPC APPROVED SDP FOR SUBDIVISION

BOHANNAN HUSTON INC and CONSENSUS PLANNING agents for WESTERN ALBUQUERQUE LAND HOLDINGS and PULTE HOMES request the referenced/ above actions for Tract N-2-A, WATERSHED SUBDIVISION zoned SU-2/ PDA, located west of TIERRA PINTADA BLVD NW between ARROYO VISTA BLVD NW and WEST CREEK PL NW containing approximately 84.7. (H-8) [deferred from 1/22/14, 2/5/14]

At the February 12, 2014 Development Review Board meeting, the Site Plan for Subdivision was approved. With the signing of the infrastructure list dated 2/12/14, and with the Grading and Drainage plan approved for Preliminary Plat, engineer stamp dated 2/7/14, the preliminary plat was approved. Sidewalk Variances for Temporary Deferral of Sidewalk Construction, and Waiver of Sidewalks to be financially guaranteed with future platting, were approved as shown on the Sidewalk Waiver Exhibit in the planning file. Subdivision Design Variances from minimum DPM design standards for the median in Willow Canyon Trail, the centerline radius in Falls Creek Trail, and 159 lots on a single access were approved based on the approved Site Development Plan for Subdivision and the request letter in the planning file.

Please note that a Preliminary Plat approval date is the date of the DRB action plus the 15-day appeal period. The Preliminary Plat approval is effective one year from that date, and if a Final Plat or extension is not completed the Preliminary Plat approval is null and void. (REF: Chapter 14 Article 14 Part 3-4 (E) Revised Ordinance.)

If you wish to appeal this decision, you must do so by February 27, 2014, in the manner described below. Appeal is to the Land Use Hearing Officer. Any person aggrieved with any determination of the Development Review Board may file an appeal on the Planning Department form, to the Planning Department, within 15 days of the Development Review Board's decision. The date the determination in question is issued is not included in the 15-day period for filing an appeal.

If the fifteenth day falls on a Saturday, Sunday or holiday as listed in the Merit System Ordinance, the next working day is considered as the deadline for filing the appeal. Such appeal shall be heard within 60 days of its filing. You will receive notice if any other person files an appeal. Successful applicants are reminded that other requirements of the City must be complied with, even after approval of the referenced application(s).

Jack Cloud, DRB Chair
Cc: BOHANNAN HUSTON INC
CONSENSUS PLANNING

file

Figure 12

INFRASTRUCTURE LIST

EXHIBIT "A"
 TO SUBDIVISION IMPROVEMENTS AGREEMENT
 DEVELOPMENT REVIEW BOARD (D.R.B.) REQUIRED INFRASTRUCTURE LIST
 DEL WEBB AT MIREHAVEN PHASE 1
 (TRACT N-2-A, WATERSHED)

Following is a summary of PUBLIC/PRIVATE infrastructure required to be constructed or financially guaranteed for the above development. This listing is not necessarily a complete listing. During the SIA process and/or in the review of the construction drawings, if the DRC Chair determines that appurtenant items and/or unforeseen items have not been included in the infrastructure listing, the DRC Chair may include those items in the listing and related financial guarantee. Likewise, if the DRC Chair determines that appurtenant or non-essential items can be deleted from the listing, those items may be deleted as well as the related portions of the financial guarantees. All such revisions require approval by the DRC Chair, the User Department and agent/owner. If such approvals are obtained, these revisions to the listing will be incorporated administratively. In addition, any unforeseen items which arise during construction which which are necessary to complete the project and which normally are the Subdivider's responsibility will be required as a condition of project acceptance and close out by the City.

SIA Sequence #	COA DRC Project #	Size	Type of Improvement	Location	From	To	Private Inspector	City Inspector	City Cnst Engineer
		12" DIA (4W) & 10" DIA (3WR)	WATERLINE W/ NEC. VALVES FHS, MJS & RJS	MIREHAVEN PARKWAY (PUBLIC ROW)	TERRA PINTADA BLVD	REDONDO PEAK DR (3WR) & DEL WEBB BLVD (BOTH)	/	/	/
		6" DIA (3WR)	WATERLINE W/ NEC. VALVES FHS, MJS & RJS	MIREHAVEN PARKWAY (PUBLIC ROW)	REDONDO PEAK DRIVE	150' SOUTH OF DEL WEBB BLVD	/	/	/
		12" DIA (4W) & 10" DIA (3WR)	WATERLINE W/ NEC. VALVES FHS, MJS & RJS	DEL WEBB BLVD	MIREHAVEN PARKWAY	COYOTE CREEK TRAIL	/	/	/
		12" DIA (4W)	WATERLINE W/ NEC. VALVES FHS, MJS & RJS	DEL WEBB BLVD	COYOTE CREEK TRAIL	CEBOLLA CREEK WAY	/	/	/
		8" DIA (4W)	WATERLINE W/ NEC. VALVES FHS, MJS & RJS	CEBOLLA CREEK WAY	DEL WEBB BLVD	IRON CREEK LANE	/	/	/
		8" DIA (4W)	WATERLINE W/ NEC. VALVES FHS, MJS & RJS	CEBOLLA CREEK WAY	IRON CREEK LANE	CEBOLLA CREEK WAY SOUTH TERMINUS	/	/	/
		6" DIA (4W)	WATERLINE W/ NEC. VALVES FHS, MJS & RJS	GOOSE LAKE TRAIL	DEL WEBB BLVD	IRON CREEK LANE	/	/	/
		8" DIA (4W) & 8" DIA (3WR)	WATERLINE W/ NEC. VALVES FHS, MJS & RJS	BEAR LAKE WAY (BOTH 4W & 3WR)	DEL WEBB BLVD (4W) COYOTE CREEK TRAIL (3WR)	WILLOW CANYON TRAIL (BOTH 4W & 3WR)	/	/	/
		8" DIA (4W)	WATERLINE W/ NEC. VALVES FHS, MJS & RJS	IRON CREEK LANE	CEBOLLA CREEK WAY	BEAR LAKE WAY	/	/	/
		6" DIA (3WR)	WATERLINE W/ NEC. VALVES FHS, MJS & RJS	COYOTE CREEK TRAIL	DEL WEBB BLVD	BEAR LAKE WAY	/	/	/
		6" DIA (3WR)	WATERLINE W/ NEC. VALVES FHS, MJS & RJS	CAVE CREEK LANE	FALLS CREEK TRAIL	BEAR LAKE WAY	/	/	/
		6" DIA (3WR)	WATERLINE W/ NEC. VALVES FHS, MJS & RJS	FALLS CREEK TRAIL	CAVE CREEK LANE	WILLOW CANYON TRAIL	/	/	/
		8" DIA (3WR)	WATERLINE W/ NEC. VALVES FHS, MJS & RJS	FALLS CREEK TRAIL & PUBLIC WATERLINE EASEMENT	WILLOW CANYON TRAIL	MIREHAVEN PARKWAY	/	/	/
		8" DIA (3WR)	WATERLINE W/ NEC. VALVES FHS, MJS & RJS	WILLOW CANYON TRAIL	BEAR LAKE WAY	DEL WEBB BLVD	/	/	/
		8" DIA (4W) & 8" DIA (3WR)	WATERLINE W/ NEC. VALVES FHS, MJS & RJS	WILLOW CANYON TRAIL	BEAR LAKE WAY	WILLOW CANYON TRAIL SOUTH TERMINUS	/	/	/
		NOTE:	A PRESSURE REDUCTION VALVE / VAULT (PRV) SHALL BE REQUIRED PER THE ABCWUA AT A LOCATION AGREED UPON BY BOTH PULTE AND THE ABCWUA OR AT THE PRESSURE ZONE BDRY.						

SIA Sequence #	COA DRC Project #	Size	Type of Improvement	Location	From	To	Private Inspector	City Inspector	City Crst Engineer
		8" DIA	SANITARY SEWER W/ NEC. MHS & SERVICES	PUBLIC EASEMENT OR ROW VIA TRACT N-2-E	MIREHAVEN PARKWAY & DEL WEBB BLVD INTERSECTION	TIERRA PINTADA BLVD	/	/	/
		8" DIA	SANITARY SEWER W/ NEC. MHS & SERVICES	DEL WEBB BLVD	MIREHAVEN PARKWAY	CEBOLLA CREEK WAY	/	/	/
		8" DIA	SANITARY SEWER W/ NEC. MHS & SERVICES	CEBOLLA CREEK WAY	CEBOLLA CREEK WAY SOUTH TERMINUS	DEL WEBB BLVD	/	/	/
		8" DIA	SANITARY SEWER W/ NEC. MHS & SERVICES	GOOSE LAKE TRAIL	LOT 81	DEL WEBB BLVD	/	/	/
		8" DIA	SANITARY SEWER W/ NEC. MHS & SERVICES	IRON CREEK LANE	LO 112	BEAR LAKE WAY	/	/	/
		8" DIA	SANITARY SEWER W/ NEC. MHS & SERVICES	BEAR LAKE WAY	IRON CREEK LANE	DEL WEBB BLVD	/	/	/
		8" DIA	SANITARY SEWER W/ NEC. MHS & SERVICES	BEAR LAKE WAY	LOT 121	WILLOW CANYON TRAIL	/	/	/
		8" DIA	SANITARY SEWER W/ NEC. MHS & SERVICES	COYOTE CREEK TRAIL	LOT 47	DEL WEBB BLVD	/	/	/
		8" DIA	SANITARY SEWER W/ NEC. MHS & SERVICES	CAVE CREEK LANE	LOT 40	FALLS CREEK TRAIL	/	/	/
		8" DIA	SANITARY SEWER W/ NEC. MHS & SERVICES	FALLS CREEK TRAIL	CAVE CREEK LANE	WILLOW CANYON TRAIL	/	/	/
		8" DIA	SANITARY SEWER W/ NEC. MHS & SERVICES	FALLS CREEK TRAIL	FALLS CREEK TRAIL EAST CUL DE SAC TERMINUS	WILLOW CANYON TRAIL	/	/	/
		8" DIA	SANITARY SEWER W/ NEC. MHS & SERVICES	WILLOW CANYON TRAIL	WILLOW CANYON TRAIL SOUTH TERMINUS	DEL WEBB BLVD	/	/	/

SIA Sequence #	COA DRC Project #	Size	Type of Improvement	Location	From	To	Private Inspector	City Inspector	City Crst Engineer
		48-54" DIA	RCP W/ NEC. MHS, LATERALS & INLETS	DEL WEBB BLVD	MIREHAVEN PARKWAY	WILLOW CANYON TRAIL	/	/	/
		48-54" DIA	RCP W/ NEC. MHS, LATERALS & INLETS	WILLOW CANYON TRAIL	MIREHAVEN ARROYO	WILLOW CANYON TRAIL SOUTH TERMINUS	/	/	/
		48" DIA	RCP W/ NEC. MHS, LATERALS & INLETS	PUBLIC SD EASEMENT ON TRACTS N-2-A-1 & N-2-A-17	MIREHAVEN ARROYO	DEL WEBB BLVD	/	/	/
		18-48" DIA	RCP W/ NEC. MHS, LATERALS & INLETS	DEL WEBB BLVD	PUBLIC SD EASEMENT ON TRACTS N-2-A-1 & N-2-A-17	CEBOLLA CREEK WAY	/	/	/
		18-30" DIA	RCP W/ NEC. MHS, LATERALS & INLETS	CEBOLLA CREEK WAY	LOT 100 / 101 PL CEBOLLA CREEK WAY	DEL WEBB BLVD	/	/	/
		18-24" DIA	RCP W/ NEC. MHS, LATERALS & INLETS	BEAR LAKE WAY & COYOTE CREEK TRAIL	WIN 100 FEET OF THE INTRSECTN OF DEL WEBB BLVD	DEL WEBB BLVD	/	/	/
		*70"-100" WIDE	NECESSARY ARROYO/CHANNEL IMPROVEMENTS W/ SD STUBS &	PUBLIC SD EASEMENT ON TRACTS N-2-A-1	TIERRA PINTADA BLVD	WEST BDRY OF TRACTS N-2-A-1	/	/	/
		LOMR	A FEMA LETTER OF MAP REVISION IS REQUIRED; A SPECIFIED FINANCIAL GUARANTY AMOUNT OF \$50,000 IS REQUIRED UNTIL AN APPROVED LOMR IS PROVIDED BY FEMA FOR THE MIREHAVEN ARROYO.				/	/	/
		5" CHANNEL	5 FT WIDE PCC PRIVATE DRAINAGE CHANNEL W/IN TRACT N-2-A-2 & N-2-A-4 FROM LOT 107 TO THE MIREHAVEN ARROYO				/	/	/
		NOTE:	PRIVATE FACILITIES COVENANT FOR 5 FT WIDE PCC PRIVATE DRAINAGE CHANNEL W/IN TRACT N-2-A-2 & N-2-A-4				/	/	/
			A MAINTENANCE AGREEMENT & EASEMENT IS REQUIRED FOR THE MIREHAVEN ARROYO.				/	/	/
			GRADING & DRAINAGE CERTIFICATION OF THE APPROVED GRADING PLAN IS REQUIRED PRIOR TO THE RELEASE OF FINANCIAL GUARANTEES				/	/	/

SIA Sequence #	COA DRC Project #	Size	Type of Improvement	Location	From	To	Private Inspector	City Inspector	City Cnst Engineer
			PUBLIC ROADWAY IMPROVEMENTS - ON-SITE.						
		22' F-F (WB) 32' F-F (EB) 12' MEDIAN	RESIDENTIAL PAVING W/ PCC CURB & GUTTER; 10' N SIDE & 4' S SIDE PCC SIDEWALK* & 6' BIKE LANE ON BOTH SIDES	MIREHAVEN PARKWAY (Major Local)	TERRA PINTADA BLVD	220 FT WEST OF TERRA PINTADA BLVD	/	/	/
		22' F-F (WB/EB) MEDIAN WIDTH VARIES (>10')	RESIDENTIAL PAVING W/ PCC CURB & GUTTER; 10' WIDE PCC SIDEWALK* N SIDE ONLY 6' BIKE LANE ON BOTH SIDES	MIREHAVEN PARKWAY (Major Local)	220 FT WEST OF TERRA PINTADA BLVD	220 FT NORTH DEL WEBB BLVD	/	/	/
		32' F-F (WB) 22' F-F (EB) 8' MEDIAN	RESIDENTIAL PAVING W/ PCC CURB & GUTTER; 10' WIDE PCC SIDEWALK* N SIDE ONLY 6' BIKE LANE ON BOTH SIDES	MIREHAVEN PARKWAY (Major Local)	220 FT NORTH DEL WEBB BLVD	DEL WEBB BLVD	/	/	/
		22' F-F (WB/EB) 8' MEDIAN	RESIDENTIAL PAVING W/ PCC CURB & GUTTER; 10' WIDE PCC SIDEWALK* N SIDE ONLY 6' BIKE LANE ON BOTH SIDES	MIREHAVEN PARKWAY (Major Local)	DEL WEBB BLVD	MIREHAVEN PARKWAY TRACT N-2-E-3 S BDRY	/	/	/
		22' F-F (OUT) 20' F-F (IN) MEDIAN VARIES	RESIDENTIAL PAVING W/ PCC CURB & GUTTER & PCC 4' WIDE SIDEWALK* ON BOTH SIDES	DEL WEBB BLVD (TRACT N-2-A-3; PRIVATE ST) (Normal Local Residential)	MIREHAVEN PARKWAY	WILLOW CANYON TRAIL	/	/	/
		32' F-F	RESIDENTIAL PAVING W/ PCC CURB & GUTTER & PCC 4' WIDE SIDEWALK* ON BOTH SIDES	DEL WEBB BLVD (TRACT N-2-A-3; PRIVATE ST) (Access Local Residential)	WILLOW CANYON TRAIL	COYOTE CREEK TRAIL	/	/	/
		28' F-F	RESIDENTIAL PAVING W/ PCC CURB & GUTTER & PCC 4' WIDE SIDEWALK* ON BOTH SIDES	DEL WEBB BLVD (TRACT N-2-A-3; PRIVATE ST)	COYOTE CREEK TRAIL	CEBOLLA CREEK WAY	/	/	/
		28' F-F	RESIDENTIAL PAVING W/ PCC CURB & GUTTER & PCC 4' WIDE SIDEWALK* ON BOTH SIDES	CEBOLLA CREEK WAY (TRACT N-2-A-3; PRIVATE ST) (Access Local Residential)	DEL WEBB BLVD	CEBOLLA CREEK WAY SOUTH TERMINUS	/	/	/
		28' F-F	RESIDENTIAL PAVING W/ PCC CURB & GUTTER & PCC 4' WIDE SIDEWALK* ON BOTH SIDES	GOOSE LAKE TRAIL (TRACT N-2-A-3; PRIVATE ST) (Access Local Residential)	DEL WEBB BLVD	IRON CREEK LANE	/	/	/
		28' F-F	RESIDENTIAL PAVING W/ PCC CURB & GUTTER & PCC 4' WIDE SIDEWALK* ON BOTH SIDES	BEAR LAKE WAY (TRACT N-2-A-3; PRIVATE ST) (Access Local Residential)	DEL WEBB BLVD	WILLOW CANYON TRAIL	/	/	/
		28' F-F	RESIDENTIAL PAVING W/ PCC CURB & GUTTER & PCC 4' WIDE SIDEWALK* ON BOTH SIDES	IRON CREEK LANE (TRACT N-2-A-3; PRIVATE ST) (Access Local Residential)	CEBOLLA CREEK WAY	BEAR LAKE WAY	/	/	/
		28' F-F	RESIDENTIAL PAVING W/ PCC CURB & GUTTER & PCC 4' WIDE SIDEWALK* ON BOTH SIDES	COYOTE CREEK TRAIL (TRACT N-2-A-3; PRIVATE ST) (Access Local Residential)	DEL WEBB BLVD	BEAR LAKE WAY	/	/	/
		28' F-F	RESIDENTIAL PAVING W/ PCC CURB & GUTTER & PCC 4' WIDE SIDEWALK* ON BOTH SIDES	CAVE CREEK LANE (TRACT N-2-A-3; PRIVATE ST) (Access Local Residential)	BEAR LAKE WAY	FALLS CREEK TRAIL	/	/	/
		28' F-F	RESIDENTIAL PAVING W/ PCC CURB & GUTTER & PCC 4' WIDE SIDEWALK* ON BOTH SIDES	FALLS CREEK TRAIL (TRACT N-2-A-3; PRIVATE ST) (Access Local Residential)	CAVE CREEK LANE	WILLOW CANYON TRAIL	/	/	/

COA DRG Project #	SIA Sequence #	Size	Type of Improvement	Location	From	To	Private Inspector	City Inspector	City Cost Engineer
		28' F-F	RESIDENTIAL PAVING W/ PCC CURB & GUTTER & PCC 4' WIDE SIDEWALK* ON BOTH SIDES	FALLS CREEK TRAIL (TRACT N-2-A-3; PRIVATE ST) (Access Local Residential)	WILLOW CANYON TRAIL	FALLS CREEK TRAIL EAST CUL DE SAC TERMINUS	/	/	/
		16' F-F (NB/SB) 4' MTBL MEDIAN	RESIDENTIAL PAVING W/ PCC CURB & GUTTER & PCC 4' WIDE SIDEWALK* ON BOTH SIDES	WILLOW CANYON TRAIL (TRACT N-2-A-3; PRIVATE ST) (Normal Local Residential)	NORTH BDRY OF LOT 159	WILLOW CANYON TRAIL SOUTH TERMINUS	/	/	/
		12' WIDE LT TURN LANE	ARTERIAL PAVING W/ PCC MEDIAN C&G, R/W & DISPS OF EXISING C&G	TIERRA PINTADA BLVD (Minor Arterial)	MIREHAVEN PARKWAY	150 FT SOUTH OF MIREHAVEN PARKWAY	/	/	/
		8' WIDE TRAIL	PCC TRAIL*	TRACT N-2-A-8	CEBOLLA CREEK WAY	WILLOW CANYON TRAIL	/	/	/
		8' WIDE TRAIL	PCC TRAIL*	TRACT N-2-A-9	BEAR LAKE WAY	DEL WEBB BLVD	/	/	/
		8' WIDE TRAIL	ASPHALT OR CRUSHER FINE TRAIL*	TRACTS N-2-A-1 & N-2-A-2	TRACT N-2-A-4	MIREHAVEN PARKWAY	/	/	/
		10' WIDE TRAIL	ASPHALT OR CRUSHER FINE TRAIL*	TRACT N-2-A-4	TRACT N-2-A-2	S. BDRY OF TRACT N-2-A-4	/	/	/

NOTE: A STREETSCAPE AGREEMENT BTWN THE CITY & DEVELOPER IS REQUIRED FOR LANDSCAPING WITHIN PUBLIC ROW. STREET LIGHTS WHERE REQUIRED PER THE COA DPM

*ALL SIDEWALKS TO BE DEFERRED ALONG FRONTAGE OF LOTS
 *SIDEWALK TO BE WAIVED ON THE SOUTH SIDE OF MIREHAVEN PARKWAY EXCEPT AS NOTED.
 **PROVIDE / INSTALL THE NECESSARY ROADWAY SIGNAGE ASSOCIATED W/ THE DEVELOPMENT AS APPROVED BY THE CITY DRC
 A SIDEWALK TO BE WAIVED ALONG DEL WEBB BLVD AND TO BE FINANCIALLY GUARANTEED WITH FUTURE PLATTING

AGENT/TOWNER: Kevin G. Patton, P.E. DATE: 2-12-14

PREPARED BY: PRINT NAME: Kevin G. Patton, P.E. DATE: 2-12-14

FIRM: BOHANNAN HUSTON INC. DATE: 2-12-14

SIGNATURE: [Signature] DATE: 2-12-14

AMAFCA: Carla S. Dumont DATE: 2-12-14

CITY ENGINEER: Carla S. Dumont DATE: 2-12-14

DESIGN REVIEW COMMITTEE REVISIONS		AGENT/TOWNER
REVISION	DATE	USER DEPARTMENT

SUBDIVISION IMPROVEMENTS AGREEMENT PUBLIC AND/OR PRIVATE
(Procedure B)

AGREEMENT TO CONSTRUCT
PUBLIC AND/OR PRIVATE SUBDIVISION IMPROVEMENTS

THIS AGREEMENT is made this 2 day of January, ~~2014~~, ²⁰¹⁵, by and between the City of Albuquerque, New Mexico ("City"), a municipal corporation, whose address is P. O. Box 1293 (One Civic Plaza), Albuquerque, New Mexico 87103, and **Pulte Homes of New Mexico, Inc.** ("Subdivider"), a [state the type of business entity, for instance, "New Mexico corporation," "general partnership," "joint venture," "individual," etc.], **a Michigan Corporation**, whose address is **7600 Jefferson NE Suite 180** and whose telephone number is **505-341-8524**, is made in Albuquerque, New Mexico, and is entered into as of the date of final execution of this Agreement.

1. Recital. The Subdivider is developing certain lands within the City of Albuquerque, Bernalillo County, New Mexico, known as [existing legal description:] **Tract N-2-A, Watershed Subdivision**, recorded on **October 17, 2013** in Book **2013C**, page **116**, as Document No. **2013115035** in the records of the Bernalillo County Clerk, State of New Mexico (the "Subdivision"). The Subdivider certifies that the Subdivision is owned by [state the name of the present real property owner exactly as shown on the real estate document conveying title in the Subdivision to the present owner:] **Pulte Homes of New Mexico, a Michigan Corporation** ("Owner").

The Subdivider has submitted and the City has approved a preliminary plat or Site Development Plan identified as **Del Webb @ Mirehaven Phase 1** describing Subdivider's Property ("Subdivider's Property").

As a result of the development of the City's Subdivision, the Subdivision Ordinance ("S.O.") and/or the Zoning Code, Section 14-16-3-11, require the Subdivider, at no cost to the City, to install certain public and/or private improvements, which are reasonably related to the development of the Subdivision, or to financially guarantee the construction of the public and/or private improvements as a prerequisite to approval of the final plat, building permit or the Site Development Plan for the Subdivision.

2. Improvements and Construction Deadline. The Subdivider agrees to install and complete the public and/or private improvements described in **Exhibit A**, the required infrastructure listing ("Improvements"), to the satisfaction of the City, on or before the **May 30, 2015**, ("Construction Completion Deadline"), at no cost to the City. The Improvements are shown in greater detail on the Subdivider's proposed and approved plans, which have been filed with the City Engineer and are identified as Project No. **650382**.

Note: To compute the Construction Completion Deadline: If a final plat will be filed after Subdivider meets the requirements of this Agreement, the Construction Completion Deadline can be no later than two years after execution of this Agreement. (See S.O. Section 14-14-3.) If a final plat will not be filed pursuant to this Agreement, the Construction Completion Deadline can be no later than one year after approval of the preliminary plat by the City's Development Review Board ("DRB"), unless the DRB grants an extension, not to exceed one additional year per extension, and the Subdivider processes an amendment to the Agreement. (See S.O. Section 14-14-3.) If this Agreement, with any amendments does not utilize the maximum time allowed for completion of construction, the Subdivider may obtain an extension of the Construction Completion Deadline if Subdivider shows adequate reason for the extension.

3. Albuquerque Bernalillo County Water Utility Authority. Pursuant to the Memorandum of Understanding between the City of Albuquerque and the Albuquerque Bernalillo County Water Utility Authority ("ABCWUA") dated March 21, 2007, the City is authorized to act on behalf of the ABCWUA with respect to improvements that involve water and sewer infrastructure.

4. Work Order Requirements. The City agrees to issue a Work Order after:

A. The Subdivider causes to be submitted all documents, and meets all requirements listed in Development Process Manual ("DPM"), Volume 1, Chapter 5, Work Order Process, and Figure 1, including submitting a Certificate of Insurance in a form acceptable to the City. The certificate must establish that the Subdivider has procured, or has caused to be procured, public liability insurance in the amount of not less than One Million Dollars (\$1,000,000) combined single limit for accidents or occurrences which cause bodily injury, death or property damage as a result of any condition of the Subdivision, the Improvements, or the Subdivider's construction activities within, or related to the Subdivision. The insurance policy must name the City of Albuquerque, its employees and elected officials, as their interest may appear, as additional insured. If the Improvements include water and wastewater infrastructure, the insurance policy must name the ABCWUA, its employees, officers and agents, as their interest may appear, as additional insureds. The Subdivider must maintain the insurance until the City accepts the public Improvements and/or approves the private Improvements. The cancellation provision must provide that if the policy is either canceled prior to the expiration date of the policy or is materially changed or not renewed, the issuing company will mail thirty (30) days written notice to the City, attention City Engineer.

B. The Subdivider complies with all applicable laws, ordinances and regulations, including, but not limited to the City Excavation Ordinance and Sidewalk Ordinance, and pays the following required engineering, staking, testing fees, and other related City fees and County Clerk recording fees:

Type of Fee	Amount
Engineering Fee	3.25%
Street Excavation and Barricading Ordinance and street restoration fees	As required per City-approved estimate (figure 7)

Note: The Subdivider must pay the City all City fees which have been incurred during construction before the City will accept the public Improvements.

5. Surveying, Inspection and Testing. The Improvements shall be inspected, surveyed and tested in accordance with all applicable laws, ordinances, and regulations, and according to the following terms:

A. Construction Surveying. Construction surveying for the construction of the public Improvements shall be performed by **Surv Tek, Inc.**, and construction surveying of the private Improvements shall be performed by **Surv Tek, Inc.** If the construction surveying is performed by an entity other than the City, the City may monitor the construction surveying and the Subdivider shall ensure that the construction surveying entity provides all construction surveying field notes, plats, reports and related data to the City which the City requires for review. Record drawings shall be provided by the entity performing the survey. The Subdivider shall pay the City a reasonable fee for any construction surveying performed by the City.

B. Construction Inspection Methods. Inspection of the construction of the public Improvements shall be performed by **Smith Engineering** and inspection of the private Improvements shall be performed by **Smith Engineering**, both New Mexico Registered Professional Engineers. If the inspection is performed by an entity other than the City, the City may monitor the inspection and the Subdivider shall ensure that the inspecting entity provides all inspection results, reports and related data to the City which the City requires for review. The City retains the right to perform its own general overall inspection of the construction project at any time prior to final acceptance of the Improvements, if deemed necessary or advisable by the City Engineer. The Subdivider shall pay the City a reasonable fee for the level of inspection performed by the City.

C. Field Testing. Field testing of the construction of the public Improvements shall be performed by **Geo-Test, Inc.** and field testing of the private Improvements shall be performed by **Geo-Test, Inc.** both certified testing laboratories under the supervision of a New Mexico Registered Professional Engineer, in accordance with the current City of Albuquerque Standard Specifications for Public Works Construction. If any field testing is performed by an entity other than the City, the City may monitor the field testing and the Subdivider shall ensure that the field testing entity provides

all field testing results, reports and related data to the City which the City requires for review. The Subdivider shall pay the City a reasonable fee for any field testing performed by the City.

D. Additional Testing. The City retains the right to perform all additional testing which the City Engineer deems is necessary or advisable, and the Subdivider shall pay the City a reasonable fee therefore.

6. Financial Guaranty. If final plat approval is not requested prior to construction of the Subdivision, a financial guaranty is not required. If final plat approval is requested, the Subdivider must provide the City with a financial guaranty in an amount of not less than 125% of the estimated cost of constructing the Improvements, as approved by the City Engineer. The financial guaranty must be irrevocable and may be in the form of a letter of credit, escrow deposit, or loan reserve letter issued by a Federally Insured Financial Institution; a bond issued by a surety qualified to do business in New Mexico; or other pledge of liquid assets which meets all City requirements. The City must be able to call the financial guaranty at any time within the sixty (60) days immediately following the Construction Completion Deadline.

To meet the City's S.O. requirements, the Subdivider has acquired, or is able to acquire, the following Financial Guaranty:

Type of Financial Guaranty: Suretybond 59BSBGU0639
Amount: \$ 2,506,283.40
Name of Financial Institution or Surety providing Guaranty:
Hartford Fire Insurance Company
Date City first able to call Guaranty (Construction Completion Deadline):
May 30, 2015
If Guaranty is a Letter of Credit or Loan Reserve, then last day City able to call Guaranty is: _____
Additional information: _____

7. Notice of Start of Construction. Before construction begins, the Subdivider shall deliver an acceptable Notice to Proceed to the City and shall arrange for a preconstruction conference and all required inspections.

8. Completion, Acceptance and Termination. When the City receives Subdivider's final acceptance package, the City shall review it for completeness and accuracy. (See DPM Volume 1, Chapter 5, Work Order Process, Step 9.) If the package is acceptable, the City shall approve the package and issue a Certificate of Completion and Acceptance for the public Improvements and a Certificate of Completion for the private Improvements. Thereafter, the Subdivider's obligations to the City pursuant to this Agreement shall terminate, with the exception of the bond or other guarantee which the Subdivider has provided to assure the materials and workmanship, as required by the S.O. After the City approves the final acceptance package, the City will promptly release this Agreement and the Financial Guaranty.

9. Conveyance of Property Rights. When the Improvements are completed, if the City does not own the real property upon, or in which, the public Improvements are constructed, the Subdivider will convey to the City all real and personal property rights which the City deems reasonably necessary, and all public Improvements, free and clear of all claims, encumbrances and liens before the City will accept the public Improvements. Conveyance may be made by appropriate dedication on the final plat of the Subdivision.

10. Reduction of Financial Guaranty Upon Partial Completion. The Subdivider shall be entitled to a reduction of the Financial Guaranty as a result of completing construction of part of the Improvements if the following conditions are met:

A. Loan Reserve Financial Guaranty. If a loan reserve letter was provided as the Financial Guaranty, the Subdivider must follow the procedures and meet the requirements detailed in the DPM, Volume 1, Chapter 5.

B. Non-Loan Reserve Financial Guaranty. If a Financial Guaranty other than a loan reserve letter has been provided, the completed Improvements must be free-standing, functionally independent of any Improvements which have not yet been completed, and completed in substantial compliance with the approved construction plans, as determined by City on-site inspection in order to qualify for a Financial Guaranty reduction. If the Improvements which have been completed meet all City requirements, the City Engineer will estimate the cost of completing the remaining Improvements. Thereafter, the Subdivider must submit the following documents to the City for review and approval:

(1) A revised Financial Guaranty in an amount of not less than 125% of the cost of completing the remaining Improvements, as estimated by the City;

(2) A bond or other instrument acceptable to the City, which guarantees the completed Improvements against defective materials and workmanship for the period required by the S.O.

(3) Conveyance of real and personal property rights which meet the requirements of section 8 of this Agreement.

After the City receives and approves the required documents, the City shall issue a Partial Certificate of Completion and Acceptance for the completed public Improvements and a Certificate of Partial Completion for the completed private Improvements.

11. Indemnification. Until the Improvements are accepted by the City, the Subdivider shall be solely responsible for maintaining the premises upon which the Improvements are being constructed in a safe condition. The Subdivider agrees to indemnify and hold harmless the City and its officials, agents and employees and, if the Improvements include water and wastewater infrastructure, the ABCWUA, its employees, officers and agents, from any claims, actions, suits or other proceedings arising from or out of the acts or omissions of the Subdivider, its agents,

representatives, contractors or subcontractors or arising from the failure of the Subdivider, its agents, representatives, contractors or subcontractors to perform any act or duty required of the Subdivider herein. The indemnification required hereunder shall not be limited as a result of the specifications of any applicable insurance coverage. Nothing herein is intended to impair any right or immunity under the laws of the State of New Mexico.

12. Assignment. This Agreement shall not be assigned without the prior written consent of the City and the Subdivider and the express written concurrence of any financial institution or surety which has undertaken to guarantee the completion of the Improvements. The City's approval will not be withheld unreasonably. If so assigned, this Agreement shall extend to and be binding upon the successors and assigns of the parties hereto.

13. Release. If the Subdivision or any part thereof is sold, conveyed or assigned, the City will not release the Subdivider from its obligations under this Agreement and will continue to hold the Subdivider responsible for all Improvements until a successor in interest to the Subdivider has entered into a Subdivision Improvements Agreement with the City. Thereafter, if the Subdivider's successor in interest has provided a substitute financial guaranty acceptable to the City, the City will release this Agreement and any related Financial Guaranty.

14. Payment for Incomplete Improvements. If the Subdivider fails to satisfactorily complete construction of the Improvements by the Construction Completion Deadline, the City may construct or cause the Improvements to be constructed as shown on the final plat and in the approved plans and specifications. The Subdivider shall be jointly and severally liable to pay to, and indemnify the City for the total cost, including, but not limited to, engineering, legal, and contingent costs, together with any damages, either direct or consequential, which the City may sustain as a result of Subdivider's failure to perform as required by this Agreement. If the direct or indirect costs and damages to the City exceed the amount of the City's Claim of Lien or any Financial Guaranty, the Subdivider shall be liable to, and shall pay, the City for all such costs and damages. The surety or sureties shall be jointly and severally liable to pay to and indemnify the City for the total cost to the extent of their obligations pursuant to any Financial Guaranty.

15. Binding on Subdivider's Property. The provisions of this Agreement constitute covenants running with Subdivider's Property for the benefit of the City and its successors and assigns until terminated, and are binding on the Subdivider and the Owner and their heirs, successors and assigns.

16. Notice. For purposes of giving formal written notice, including notice of change of address, the Subdivider's and the City's addresses are as stated in the first paragraph of this Agreement. Notice may be given either in person or by certified U.S. mail, postage paid. Notice will be considered to have been received within six (6) days after the notice is mailed if there is no actual evidence of receipt.

17. Entire Agreement. This Agreement contains the entire agreement of the parties and supersedes any and all other agreements or understandings, oral or written, whether previous to the execution hereof or contemporaneous herewith.

18. Changes to Agreement. Changes to this Agreement are not binding unless made in writing, signed by both parties.

19. Construction and Severability. If any part of this Agreement is held to be invalid or unenforceable, the remainder of the Agreement will remain valid and enforceable if the remainder is reasonably capable of completion.

20. Captions. The captions to the sections or paragraphs of this Agreement are not part of this Agreement and will not affect the meaning or construction of any of its provisions.

21. Form not Changed. Subdivider agrees that changes to this form are not binding unless initialed by the subdivider and signed by the City Legal Department on this form.

22. Authority to Execute. If the Subdivider signing below is not the Owner of the Subdivision, the Owner must execute the Power of Attorney below.

Executed on the date stated in the first paragraph of this Agreement.

SUBDIVIDER: Pulte Homes of New Mexico, Inc., a Michigan corporation

CITY OF ALBUQUERQUE

By [Signature]: 

By: 



Name [Print]: Garret Price

Shahab Biazar, P.E., Acting City Engineer

Title: VP Land

Dated: Jan. 2, 2015

Dated: 11/10/14

 01/21/15  12-31-14

SUBDIVIDER'S NOTARY

STATE OF New Mexico)
) ss.
COUNTY OF Bernalillo)

This instrument was acknowledged before me on this 6 day of November, 2014, by [name of person:] Garret Price [title or capacity, for instance, "President" or "Owner":] VP Land of [Subdivider:] Pulte Homes of New Mexico, Inc., a Michigan corporation.



Polly E Lyders
Notary Public

My Commission Expires: 10/19/15

CITY'S NOTARY

STATE OF NEW MEXICO)
) ss.
COUNTY OF BERNALILLO)

This instrument was acknowledged before me on this 2 day of January, 2014, by Shahab Biazar, P.E., Acting City Engineer of the City of Albuquerque, a municipal corporation, on behalf of said corporation.

(SEAL)

[Signature]
Notary Public

My Commission Expires: 8-13-17

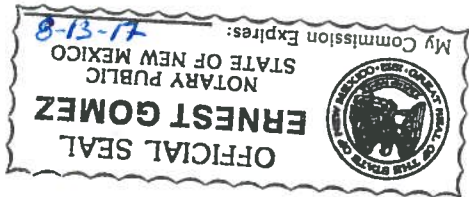

[EXHIBIT A ATTACHED]
[POWER OF ATTORNEY ATTACHED IF SUBDIVIDER
IS NOT THE OWNER OF THE SUBDIVISION]

650382

Current DRG
Project No.

Date Submitted: 11/27/2013
 Date Site Plan Approved: 9/11/2013
 Date Preliminary Plat Approved: 7-23-13
 Date Preliminary Plat Expires: 12-23-14
 DRB Project No. 1006864



Figure 12

INFRASTRUCTURE LIST

EXHIBIT "A"
 TO SUBDIVISION IMPROVEMENTS AGREEMENT
 DEVELOPMENT REVIEW BOARD (D.R.B.) REQUIRED INFRASTRUCTURE LIST
 PULTE AT MIREHAVEN PHASE 1
 (TRACT N-2-E, WATERSHED)

Following is a summary of PUBLIC/PRIVATE Infrastructure required to be constructed or financially guaranteed for the above development. This listing is not necessarily a complete listing. During the SIA process and/or in the review of the construction drawings, if the DRG Chair determines that unforseen items and/or unforseen items have not been included in the infrastructure listing, the DRG Chair may include those items in the listing and related financial guarantee. Likewise, if the DRG Chair determines that unforseen items can be deleted from the listing, those items may be deleted as well as the related portions of the financial guarantees. All such revisions require approval by the DRG Chair, the User Department and agent/owner. If such approvals are obtained, these revisions to the listing will be incorporated administratively. In addition, any unforseen items which arise during construction which which are necessary to complete the project and which normally are the Subdivider's responsibility will be required as a condition of project acceptance and close out by the City.

SIA Sequence #	COA DRG Project #	Size	Type of improvement	Location	From	To	Private Inspector	City Inspector	City Crst Engineer
			PUBLIC WATERLINE IMPROVEMENTS						
		12" DIA (4W) & 10" DIA (3WR)	WATERLINE W/ NEC. VALVES FHS, MJ'S & RJ'S	MIREHAVEN PARKWAY	TERRA PINTADA BLVD	REDONDO PEAK DR (3WR) & DEL WEBB BLVD (BOTH)	/	/	/
		6" DIA (3WR)	WATERLINE W/ NEC. VALVES FHS, MJ'S & RJ'S	MIREHAVEN PARKWAY	REDONDO PEAK DRIVE	150' SOUTH OF REDONDO PEAK AVENUE	/	/	/
		8" DIA (3WR)	WATERLINE W/ NEC. VALVES FHS, MJ'S & RJ'S	REDONDO PEAK DRIVE	MIREHAVEN PARKWAY	FENTON LAKE ROAD	/	/	/
		8" DIA (3WR)	WATERLINE W/ NEC. VALVES FHS, MJ'S & RJ'S	FENTON LAKE ROAD	REDONDO PEAK DRIVE	REDONDO PEAK DRIVE	/	/	/
		4" DIA (3WR)	WATERLINE W/ NEC. VALVES FHS, MJ'S & RJ'S	BRAZOS RIDGE CIRCLE	REDONDO PEAK DRIVE	REDONDO PEAK DRIVE	/	/	/
		6" DIA (3WR)	WATERLINE W/ NEC. VALVES FHS, MJ'S & RJ'S	GREEN MESA ROAD	FENTON LAKE ROAD	ABO CANYON DRIVE	/	/	/
		6" DIA (3WR)	WATERLINE W/ NEC. VALVES FHS, MJ'S & RJ'S	ABO CANYON DRIVE	REDONDO PEAK DRIVE	FENTON LAKE ROAD	/	/	/
		8" DIA (3WR)	WATERLINE W/ NEC. VALVES FHS, MJ'S & RJ'S	ABO CANYON DRIVE	REDONDO PEAK DRIVE	ABO CANYON DRIVE SOUTH TERMINUS	/	/	/
		8" DIA (3WR)	WATERLINE W/ NEC. VALVES FHS, MJ'S & RJ'S	PUBLIC WL EASEMENT IN TRACT N-2-E-4	ABO CANYON DRIVE	TERRA PINTADA BLVD	/	/	/

1052 I.L.

COA DRC Project #	SIA Sequence #	Type of Improvement	Location	From	To	Private Inspector	City Inspector	City Crst Engineer
		PUBLIC SANITARY SEWER IMPROVEMENTS						
		8" DIA SANITARY SEWER W/ NEC. MHS & SERVICES	REDONDO PEAK DRIVE	DEL WEBB BLVD	FENTON LAKE ROAD	/	/	/
		8" DIA SANITARY SEWER W/ NEC. MHS & SERVICES	BRAZOS RIDGE CIRCLE	HIGH PT IN BRAZOS RIDGE CIRCLE	REDONDO PEAK DRIVE	/	/	/
		8" DIA SANITARY SEWER W/ NEC. MHS & SERVICES	FENTON LAKE ROAD	REDONDO PEAK DRIVE	REDONDO PEAK DRIVE	/	/	/
		8" DIA SANITARY SEWER W/ NEC. MHS & SERVICES	GREEN MESA ROAD	HIGH PT IN GREEN MESA ROAD	ABO CANYON DRIVE	/	/	/
		8" DIA SANITARY SEWER W/ NEC. MHS & SERVICES	ABO CANYON DRIVE	HIGH PT IN ABO CANYON DRIVE (NEAR FENTON LAKE)	REDONDO PEAK DRIVE	/	/	/
		8" DIA SANITARY SEWER W/ NEC. MHS & SERVICES	PUBLIC SAS EASEMENT LOT 37	REDONDO PEAK DRIVE LOW PT	PUBLIC SAS EASEMENT IN TRACT N-2-E-4	/	/	/
		8" DIA SANITARY SEWER W/ NEC. MHS & SERVICES	PUBLIC SAS EASEMENT IN TRACT N-2-E-4	PUBLIC SAS EASEMENT LOT 37	TERRA PINTADA BLVD	/	/	/

COA DRC Project #	SIA Sequence #	Type of Improvement	Location	From	To	Private Inspector	City Inspector	City Crst Engineer
		18-36" DIA RCP W/ NEC. MHS, LATERALS & INLETS	PUBLIC SD EASEMENT	MIREHAVEN PARKWAY INLETS IN ROADWAY	MIREHAVEN ARROYO IMPROVEMENTS	/	/	/
		18-42" DIA RCP W/ NEC. MHS, LATERALS & INLETS	REDONDO PEAK DRIVE	LOT 41	LOT 33	/	/	/
		18-24" DIA RCP W/ NEC. MHS, LATERALS & INLETS	ABO CANYON DRIVE	200 FT NORTH OF REDONDO PEAK	REDONDO PEAK DRIVE	/	/	/
		54" DIA RCP W/ NEC. MHS, LATERALS & INLETS	TRACT N-2-E-6	REDONDO PEAK DRIVE LOW PT	PUBLIC SD EASEMENT IN TRACT N-2-E-4	/	/	/
		60-96" DIA RCP W/ NEC. MHS, LATERALS & INLETS	PUBLIC SD EASEMENT IN TRACT N-2-E-4	TRACT N-2-E-6	TERRA PINTADA BLVD EXISTING SD STUB	/	/	/
		36-42" DIA RCP W/ NEC. MHS, LATERALS & INLETS	MIREHAVEN PARKWAY	MIREHAVEN PARKWAY LOW PT (WEST OF LOT 55)	REDONDO PEAK DRIVE	/	/	/
		42-60" DIA RCP W/ NEC. MHS, LATERALS & INLETS	PUBLIC SD EASEMENT TRACT N-2-A	MIREHAVEN PARKWAY	MIREHAVEN ARROYO	/	/	/
		70-100" WIDE NECESSARY ARROYO CHANNEL	MIREHAVEN ARROYO	TERRA PINTADA BLVD	WEST BDRY OF TRACT N-2-A	/	/	/
		48" DIA RCP W/ NEC. MHS, LATERALS & INLETS	PUBLIC SD EASEMENT IN TRACT N-2-E-4	60" RCP SD	170 FT SOUTH OF 60" RCP SD	/	/	/
		LOMR	A FEMA LETTER OF MAP REVISION IS REQUIRED; A \$50,000 FINANCIAL GUARANTY AMOUNT WILL BE REQUIRED BY DEVELOPER UNTIL A LOMR IS PROVIDED BY FEMA			/	/	/
		NOTE:	A GRADING AND DRAINAGE CERTIFICATION OF THE APPROVED GRADING PLAN IS REQUIRED PRIOR TO THE RELEASE OF FINANCIAL GUARANTEES			/	/	/

PUBLIC STORM DRAIN IMPROVEMENTS

COA DRC Project #	SIA Sequence #	Type of Improvement	Location	From	To	Private Inspector	City Inspector	City Crst Engineer
		18-36" DIA RCP W/ NEC. MHS, LATERALS & INLETS	PUBLIC SD EASEMENT	MIREHAVEN PARKWAY INLETS IN ROADWAY	MIREHAVEN ARROYO IMPROVEMENTS	/	/	/
		18-42" DIA RCP W/ NEC. MHS, LATERALS & INLETS	REDONDO PEAK DRIVE	LOT 41	LOT 33	/	/	/
		18-24" DIA RCP W/ NEC. MHS, LATERALS & INLETS	ABO CANYON DRIVE	200 FT NORTH OF REDONDO PEAK	REDONDO PEAK DRIVE	/	/	/
		54" DIA RCP W/ NEC. MHS, LATERALS & INLETS	TRACT N-2-E-6	REDONDO PEAK DRIVE LOW PT	PUBLIC SD EASEMENT IN TRACT N-2-E-4	/	/	/
		60-96" DIA RCP W/ NEC. MHS, LATERALS & INLETS	PUBLIC SD EASEMENT IN TRACT N-2-E-4	TRACT N-2-E-6	TERRA PINTADA BLVD EXISTING SD STUB	/	/	/
		36-42" DIA RCP W/ NEC. MHS, LATERALS & INLETS	MIREHAVEN PARKWAY	MIREHAVEN PARKWAY LOW PT (WEST OF LOT 55)	REDONDO PEAK DRIVE	/	/	/
		42-60" DIA RCP W/ NEC. MHS, LATERALS & INLETS	PUBLIC SD EASEMENT TRACT N-2-A	MIREHAVEN PARKWAY	MIREHAVEN ARROYO	/	/	/
		70-100" WIDE NECESSARY ARROYO CHANNEL	MIREHAVEN ARROYO	TERRA PINTADA BLVD	WEST BDRY OF TRACT N-2-A	/	/	/
		48" DIA RCP W/ NEC. MHS, LATERALS & INLETS	PUBLIC SD EASEMENT IN TRACT N-2-E-4	60" RCP SD	170 FT SOUTH OF 60" RCP SD	/	/	/
		LOMR	A FEMA LETTER OF MAP REVISION IS REQUIRED; A \$50,000 FINANCIAL GUARANTY AMOUNT WILL BE REQUIRED BY DEVELOPER UNTIL A LOMR IS PROVIDED BY FEMA			/	/	/
		NOTE:	A GRADING AND DRAINAGE CERTIFICATION OF THE APPROVED GRADING PLAN IS REQUIRED PRIOR TO THE RELEASE OF FINANCIAL GUARANTEES			/	/	/

COA DRC Project #	SIA Sequence #	Type of Improvement	Location	From	To	Private Inspector	City Inspector	City Crst Engineer
		18-36" DIA RCP W/ NEC. MHS, LATERALS & INLETS	PUBLIC SD EASEMENT	MIREHAVEN PARKWAY INLETS IN ROADWAY	MIREHAVEN ARROYO IMPROVEMENTS	/	/	/
		18-42" DIA RCP W/ NEC. MHS, LATERALS & INLETS	REDONDO PEAK DRIVE	LOT 41	LOT 33	/	/	/
		18-24" DIA RCP W/ NEC. MHS, LATERALS & INLETS	ABO CANYON DRIVE	200 FT NORTH OF REDONDO PEAK	REDONDO PEAK DRIVE	/	/	/
		54" DIA RCP W/ NEC. MHS, LATERALS & INLETS	TRACT N-2-E-6	REDONDO PEAK DRIVE LOW PT	PUBLIC SD EASEMENT IN TRACT N-2-E-4	/	/	/
		60-96" DIA RCP W/ NEC. MHS, LATERALS & INLETS	PUBLIC SD EASEMENT IN TRACT N-2-E-4	TRACT N-2-E-6	TERRA PINTADA BLVD EXISTING SD STUB	/	/	/
		36-42" DIA RCP W/ NEC. MHS, LATERALS & INLETS	MIREHAVEN PARKWAY	MIREHAVEN PARKWAY LOW PT (WEST OF LOT 55)	REDONDO PEAK DRIVE	/	/	/
		42-60" DIA RCP W/ NEC. MHS, LATERALS & INLETS	PUBLIC SD EASEMENT TRACT N-2-A	MIREHAVEN PARKWAY	MIREHAVEN ARROYO	/	/	/
		70-100" WIDE NECESSARY ARROYO CHANNEL	MIREHAVEN ARROYO	TERRA PINTADA BLVD	WEST BDRY OF TRACT N-2-A	/	/	/
		48" DIA RCP W/ NEC. MHS, LATERALS & INLETS	PUBLIC SD EASEMENT IN TRACT N-2-E-4	60" RCP SD	170 FT SOUTH OF 60" RCP SD	/	/	/
		LOMR	A FEMA LETTER OF MAP REVISION IS REQUIRED; A \$50,000 FINANCIAL GUARANTY AMOUNT WILL BE REQUIRED BY DEVELOPER UNTIL A LOMR IS PROVIDED BY FEMA			/	/	/
		NOTE:	A GRADING AND DRAINAGE CERTIFICATION OF THE APPROVED GRADING PLAN IS REQUIRED PRIOR TO THE RELEASE OF FINANCIAL GUARANTEES			/	/	/

Private Inspector	City Inspector	City Cnst Engineer
/	/	/
/	/	/
/	/	/
/	/	/
/	/	/
/	/	/

From	To
REDONDO PEAK DRIVE	REDONDO PEAK DRIVE
ABO CANYON DRIVE	MIREHAVEN PARKWAY
TIERRA PINTADA BLVD	ABO CANYON DRIVE
TIERRA PINTADA BLVD	FENTON LAKE ROAD

Location	Type of Improvement	Size
BRAZOS RIDGE CIRCLE (Access Local Residential)	RESIDENTIAL PAVING W/ PCC CURB & GUTTER & PCC 4' WIDE SIDEWALK** ON BOTH SIDES	28' F-F
PUBLIC PED ACCESS ESMNT TRACTS N-2-E-3	PCC TRAIL†*	10' WIDE TRAIL
PUBLIC PED ACCESS ESMNT TRACTS N-2-E-4	PCC TRAIL†*	10' WIDE TRAIL
PUBLIC PED ACCESS ESMNT TRACTS N-2-E-4 (BRWN LOTS 15 & 16)	PCC TRAIL†*	4' WIDE TRAIL

NOTE: A STREETScape AGREEMENT BTWN THE CITY & DEVELOPER IS REQUIRED FOR LANDSCAPING WIN PUBLIC ROW. STREET LIGHTS ARE REQUIRED PER THE COA DPM

*ALL SIDEWALKS TO BE DEFERRED ALONG FRONTAGE OF LOTS
 †SIDEWALK TO BE WAIVED ON THE SOUTH SIDE OF MIREHAVEN PARKWAY EXCEPT AS NOTED.
 **PROVIDE / INSTALL THE NECESSARY ROADWAY SIGNAGE ASSOCIATED W/ THE DEVELOPMENT AS APPROVED BY THE CITY DRC

AGENT/OWNER: KEVIN G. PATTON, P.E. DEVELOPMENT REVIEW BOARD MEMBER APPROVALS: Carl S. Dumont DATE: 12-31-13

PREPARED BY: PRINT NAME: BOHANNAN JUSTON INC. PARKS & RECREATION SERVICES Recreation DATE: 12-31-13

FIRM: Allen Peterson TRANSPORTATION DEVELOPMENT AMAFCA DATE: 12-31-13

SIGNATURE: [Signature] ABCWUA CITY ENGINEER DATE: 12-31-13

MAJIMUM TIME ALLOW TO CONSTRUCT IMPROVEMENTS WITHOUT A DRB EXTENSION: _____ DATE: _____

REVISION	DATE	DRC CHAIR	USER DEPARTMENT	AGENT/OWNER

15+
EXTENSION AGREEMENT
Procedure "B"

PROJECT NO. 650382

This Agreement made this 8th day of July, 20 15, by and between the City of Albuquerque, New Mexico, a municipal corporation ("City") and (name of developer/subdivider:) **Pulte Homes of New Mexico, Inc., a Michigan corporation** ("Subdivider"), whose address is **7601 Jefferson NE Ste 320** and whose telephone number is **505-341-8524** is made in Albuquerque, New Mexico and is entered into as of the date of final execution of this Agreement.

WHEREAS, the City and the Subdivider entered into an Agreement on the **2nd** day of **January, 2015**, which was recorded on **January 9, 2015**, in Book N/A, pages **1** through **12**, as Document No. **2015001801** in the records of Bernalillo County Clerk, State of New Mexico ("Earlier Agreement"), by which the Subdivider agreed to complete the construction of certain infrastructure improvements on or before the **30** day of **May, 2015**; and

WHEREAS, the Earlier Agreement was amended by a _____ Extension Agreement dated _____ recorded on _____, in Book _____, pages _____ through _____, as Document No. _____ in the records of Bernalillo County Clerk, State of New Mexico, extending the construction deadline to _____; and

WHEREAS, the Earlier Agreement was amended by a _____ Extension Agreement dated _____ recorded on _____, in Book _____, pages _____ through _____, as Document No. _____ in the records of Bernalillo County Clerk, State of New Mexico, extending the construction deadline to _____; and

WHEREAS, it appears that the Subdivider will be unable to complete construction of the improvements by the deadline specified in the Agreement; and

WHEREAS, the City is willing to grant Subdivider an extension of time in which to complete construction of all or part of the improvements, provided the Subdivider posts an acceptable financial guaranty, as required by the City's Subdivision Ordinance and the Development Process Manual; and

WHEREAS, the Subdivider is able to provide the required financial guaranty;

NOW THEREFORE in consideration of the above and the mutual promises contained herein, the parties agree:

Doc# 2015059904

07/13/2015 02:52 PM Page: 1 of 3
AGRE R:\$25.00 M. Toulouse Oliver, Bernalillo County



1. The required completion date for construction of the improvements, as set forth in the attached **Exhibit A**, is extended (Complete either A or B :)

A. For all improvements, the 30 day of May, 2016

B. On portions of the improvements as follows:

<u>IMPROVEMENTS</u>	<u>COMPLETION DATE</u>
_____	_____
_____	_____
_____	_____

2. With this Extension Agreement, Subdivider has provided the City with the following financial guaranty:

Type of Financial Guaranty: Surety Bond 59BSGU0639
Amount: \$ 2,506,283.40
Name of Financial Institution or Surety providing Guaranty:
Hartford Fire Insurance Company
Date City first able to call Guaranty (Construction Completion Deadline):
May 30, 2016
If Guaranty is a Letter of Credit or Loan Reserve, then last day City able to call Guaranty is: _____
Additional information: _____

3. The parties agree that all terms and conditions of the Earlier Agreement not in conflict with this Extension Agreement shall remain valid, in force, and binding upon the parties. By executing this Agreement, the parties' only intention is to extend the construction completion deadline established in the Earlier Agreement and establish a revised financial guaranty for the benefit of the City.

Executed on the date stated in the first paragraph of this Agreement.

SUBDIVIDER: Pulte Homes of New Mexico, Inc.,
a Michigan corporation

CITY OF ALBUQUERQUE:

By [signature]: 
Name [print]: Garret Price
Title: VP Land
Dated: 6/5/15

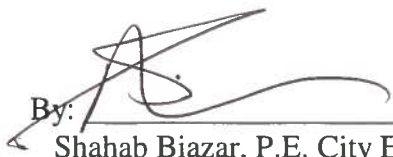
By: 
Shahab Biazar, P.E. City Engineer
Dated: 7/8/15

**AMENDMENT TO AGREEMENT TO
CONSTRUCT SUBDIVISION IMPROVEMENTS**

City Project # 650382

City Engineer's Signature Date: April 19, 2016

WHEREAS, the City and the Subdivider entered into an Agreement to Construct Public and/or Private Subdivision Improvements ("Original Agreement") on January 2, 2015, which was recorded on January 9, 2015, as Document No. 2015001801 in the records of the Bernalillo County Clerk, State of New Mexico, wherein the Subdivider agreed to satisfactorily construct certain infrastructure improvements.

WHEREAS, the Subdivider has requested to financially guarantee the construction of the public and/or private infrastructure; and

WHEREAS, the Subdivider is able to provide the required financial guaranty.

THEREFORE, the Subdivider and the City agree to amend the Original Agreement as follows:

1. Amending Section 6. Financial Guaranty, second paragraph, to read as follows:

To meet the Subdivision Ordinance requirements, the subdivider has acquired or is able to acquire the following "Financial Guaranty":

Type of Financial Guaranty: Surety Bond #59BSBGU0639

Amount: \$ 346,085.08

Name of Financial Institution or Surety providing Guaranty:

Hartford Fire Insurance Company

Date City first able to call Guaranty (Construction Completion Deadline):

May 30, 2016

If Guaranty is a Letter of Credit or Loan Reserve, then last day City able to call Guaranty is: _____

Additional information: _____

2. Other Terms Unchanged: Except as amended herein, the terms and conditions of the Original Agreement will remain unchanged and will continue in full force and effect unless there is a conflict between the terms and conditions of this Amendment, and the terms and conditions of the Original Agreement, in which case the terms and conditions of the Amendment to the Original Agreement will control.

Doc# 2016036481

04/21/2016 02:54 PM Page: 1 of 2
AMND R:\$25.00 M: Toulouse Oliver, Bernalillo County



DEVELOPER INQUIRY SHEET

To obtain NA/HOA Contact Information for Application Submittal to the Planning Department.

The Office of Neighborhood Coordination (ONC) located in Room 500 (5th floor) of the Plaza Del Sol Building, 600 Second Street NW is where you obtain NA/HOA Information for your Planning Submittal.

You can submit your Developer Inquiry Sheet the following ways: 1) in person at the address listed above; 2) fax to - 505-924-3460; or 3) you can e-mail the Zone Map and Developer Inquiry Sheet to BOTH: Stephani Winklepleck at swinklepleck@cabq.gov -AND- Dalaina Carmona at dcarmona@cabq.gov and one of us will do for you.

ONC will need the following information **BEFORE** any NA/HOA Information will be released to the Applicant/Agent on any Planning Submittal being presented to the Planning Department. If you have any questions, please feel free to contact our office at 505-924-3914.

Zone Map and this Developer Inquiry Sheet MUST be provided with request.

Please mark/hatch Zone Map where Property is located.

Your Developer Inquiry is for the following:

Cell Tower Submittal: Free-Standing Tower -OR- Concealed Tower

EPC Submittal DRB Submittal LUCC Submittal Liquor Submittal

AA Submittal City Project Submittal ZHE Submittal (need address/zone map # only)

CONTACT NAME: Yolanda Moyer

COMPANY NAME: Bohannan Huston Inc.

ADDRESS/ZIP: 7500 Jefferson NE, Albuquerque, NM 87109

Phone: 505-823-1000 Fax: 505-798-7988 E-mail: ypadilla@bhinc.com

LEGAL DESCRIPTION INFORMATION

LEGAL DESCRIPTION OF THE SUBJECT SITE FOR THIS PROJECT SUBMITTAL IS

DESCRIBED BELOW (i.e., Lot A, Block A, of the For Your Information Subdivision):

Tract N-2-A-1 Del Webb @ Mirehaven Phase 1 – Mirehaven Arroyo

LEGAL DESCRIPTION

LOCATED ON TIERRA PINTADA BLVD.

STREET NAME (ex. - 123 Main St. NW) OR OTHER IDENTIFYING LANDMARK

BETWEEN ARROYO VISTA BLVD. AND

STREET NAME OR OTHER IDENTIFYING LANDMARK

UNSER BLVD.

STREET NAME OR OTHER IDENTIFYING LANDMARK

THE SITE IS LOCATED ON THE FOLLOWING ZONE ATLAS PAGE (H-8/H-9).

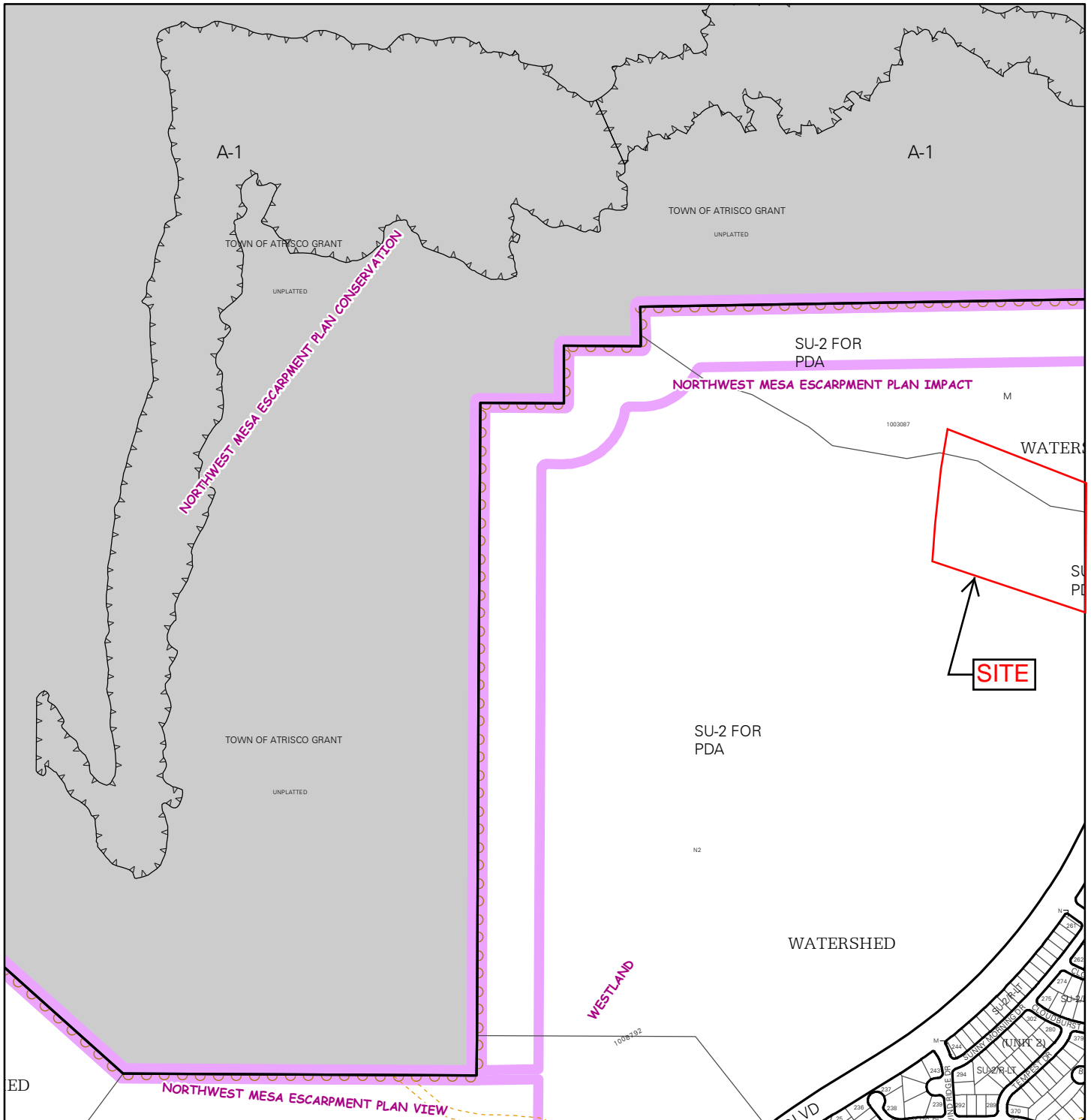

For more current information and details visit: <http://www.cabq.gov/gis>

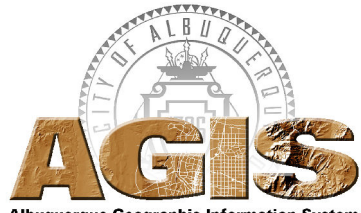

Map amended through: 6/7/2013

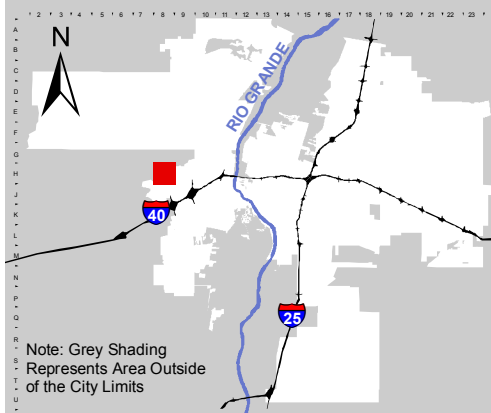

Note: Grey Shading Represents Area Outside of the City Limits

Zone Atlas Page:
H-08-Z

Selected Symbols

SECTOR PLANS	Escarpment
Design Overlay Zones	2 Mile Airport Zone
City Historic Zones	Airport Noise Contours
H-1 Buffer Zone	Wall Overlay Zone
Petroglyph Mon.	

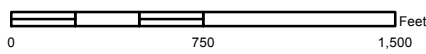

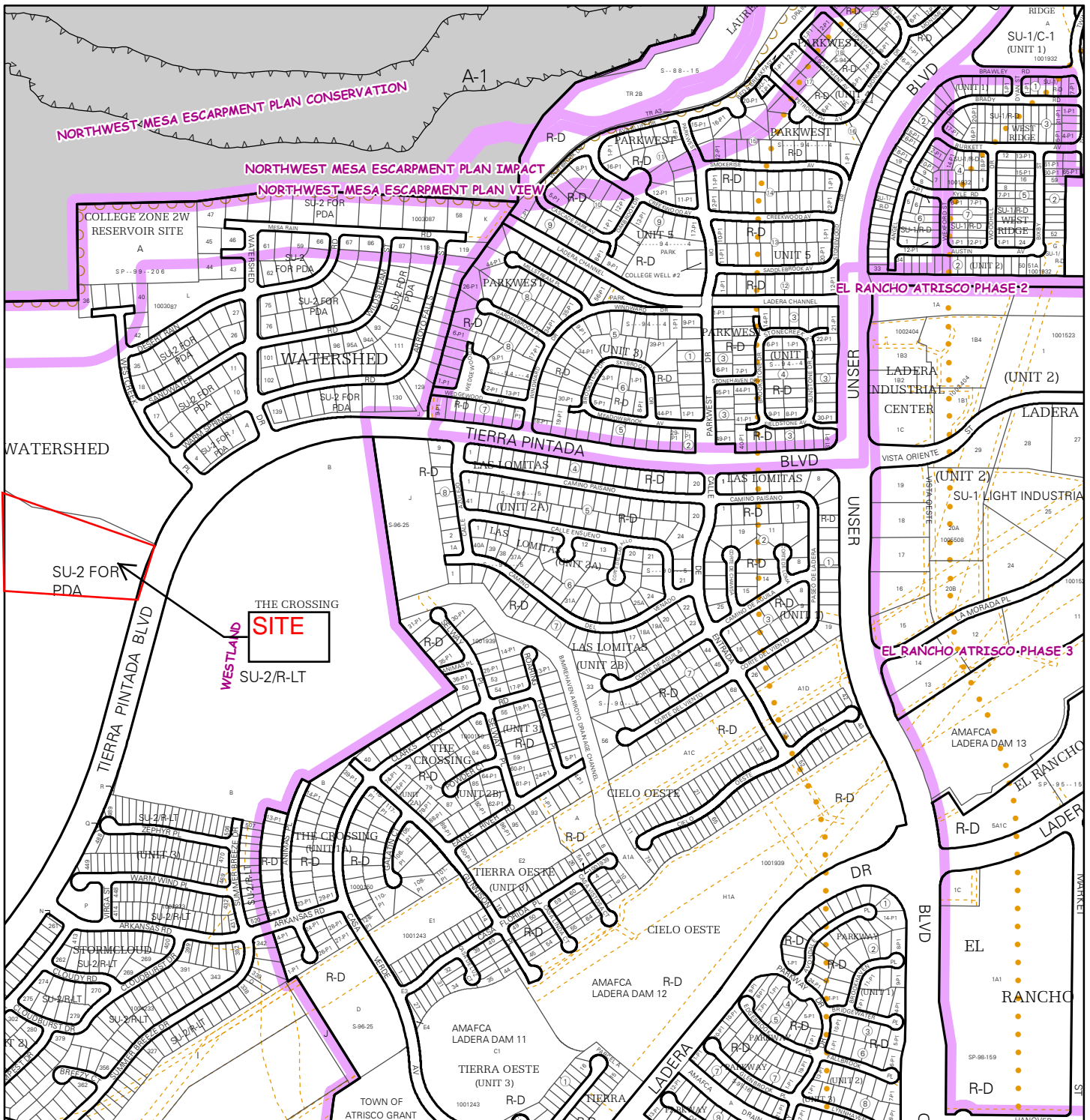

For more current information and details visit: <http://www.cabq.gov/gis>

Map amended through: 6/7/2013

Note: Grey Shading Represents Area Outside of the City Limits

Zone Atlas Page:
H-09-Z

Selected Symbols

- SECTOR PLANS
- Design Overlay Zones
- City Historic Zones
- H-1 Buffer Zone
- Petroglyph Mon.
- Escarpment
- 2 Mile Airport Zone
- Airport Noise Contours
- Wall Overlay Zone

0 750 1,500 Feet



City of Albuquerque
P.O. Box 1293, Albuquerque, NM 87103

June 29, 2016

Yolanda Moyer
Bohannan Huston Inc.
7500 Jefferson NE/87109
Phone: 505-823-1000/ Fax: 505-798-7988
E-mail: ypadilla@bhinc.com

Dear: Yolanda

Thank you for your inquiry of **June 29, 2016** requesting the names of **ALL Neighborhood and/or Homeowners Associations** who would be affected under the provisions of O-92 by your proposed project at **(DRB SUBMITTAL) TRACT N-2-A-1, DEL WEBB @ MIREHAVEN PHASE 1 - MIREHAVEN ARROYO LOCATED ON TIERRA PINTADA BLVD. BETWEEN ARROYO VISTA BLVD. AND UNSER BLVD.** zone map **H-8-9.**

Our records indicate that the **ALL Neighborhood and/or Homeowners Associations** affected by this proposal and the contact names are as follows:

SEE ATTACHMENT "A" FOR THE NAMES OF THE NA/HOA'S THAT NEED TO BE CONTACTED IN REGARDS TO THIS PLANNING SUBMITTAL – please attach this letter and "Attachment A" to your Application Packet ALONG with copies of the letters and certified mail receipts to the NA/HOA's.

Please note that according to O-92 you are required to notify each of these contact persons by **certified mail, return receipt requested, before** the Planning Department will accept your application filing. **IMPORTANT! Failure of adequate notification may result in your Application Hearing being deferred for 30 days.** If you have any questions about the information provided, please contact me at (505) 924-3906 or via an e-mail message at dlcarmona@cabq.gov or by fax at (505) 924-3913.

Sincerely,

Dalaina Carmona

Senior Administrative Assistant
OFFICE OF NEIGHBORHOOD COORDINATION
Planning Department

PLEASE NOTE: The Neighborhood Association information listed in this letter is valid for one (1) month. If you haven't filed your application within one (1) month of the date of this letter - you will need to get an updated letter from our office. It is your responsibility to provide current information - outdated information may result in a deferral of your case.

LETTERS MUST BE SENT TO BOTH CONTACTS OF EACH NEIGHBORHOOD ASSOCIATION.

!!!Notice to Applicants!!!

SUGGESTED INFORMATION FOR NEIGHBORHOOD NOTIFICATION LETTERS

Applicants for Zone Change, Site Plan, Sector Development Plan approval or an amendment to a Sector Development Plan by the EPC, DRB, etc. are required under Council Bill O-92 to notify all affected recognized neighborhood associations **PRIOR TO FILING THE APPLICATION TO THE PLANNING DEPARTMENT**. Because the purpose of the notification is to ensure communication as a means of identifying and resolving problems early, it is essential that the notification be fully informative.

WE RECOMMEND THAT THE NOTIFICATION LETTER INCLUDE THE FOLLOWING INFORMATION:

1. The street address of the subject property.
2. The legal description of the property, including lot or tract number (if any), block number (if any), and name of the subdivision.
3. A physical description of the location, referenced to streets and existing land uses.
4. A complete description of the actions requested of the EPC:
 - a) If a **ZONE CHANGE OR ANNEXATION**, the name of the existing zone category and primary uses and the name of the proposed category and primary uses (i.e., "from the R-T Townhouse zone, to the C-2 Community Commercial zone").
 - b) If a **SITE DEVELOPMENT OR MASTER DEVELOPMENT PLAN** approval or amendment describe the physical nature of the proposal (i.e., "an amendment to the approved plan to allow a drive-through restaurant to be located just east of the main shopping center entrance off Montgomery Blvd.").
 - c) If a **SECTOR DEVELOPMENT PLAN OR PLAN AMENDMENT** a general description of the plan area, plan concept, the mix of zoning and land use categories proposed and description of major features such as location of significant shopping centers, employment centers, parks and other public facilities.
 - d) The name, address and telephone number of the applicant and of the agent (if any). In particular the name of an individual contact person will be helpful so that neighborhood associations may contact someone with questions or comments.

Information from the Office of Neighborhood Coordination

The following information should always be in **each** application packet that you submit for an EPC or DRB application. Listed below is a "Checklist" of the items needed.

- ONC's "Official" Letter to the applicant (if there are associations). A copy must be submitted with application packet -OR-**
- The ONC "Official" Letter (if there are no associations). A copy must be submitted with application packet.
- Copies of Letters to Neighborhood Associations (if there are associations). A copy must be submitted with application packet.**
- Copies of the certified receipts to Neighborhood Associations (if there are associations). A copy must be submitted with application packet.**

Just a reminder - Our ONC "Official" Letter is only valid for a one (1) month period and if you haven't submitted your application by this date, you will need to get an updated letter from our office.

Any questions, please feel free to contact Dalaina at 924-3906 or via an e-mail message at dlcarmona@cabq.gov.

Thank you for your cooperation on this matter.

(below this line for ONC use only)

Date of Inquiry: **6/29/16** Time Entered: **2:54 p.m.** ONC Rep. Initials: **DC**

ATTACHMENT "A"

June 29, 2016

Yolanda Moyer

Bohannon Huston Inc.

7500 Jefferson NE/87109

Phone: 505-823-1000/ Fax: 505-798-7988

E-mail: ypadilla@bhinc.com

TRES VOLCANES N.A. (TVN) "R"

***Thomas Borst**

1908 Selway Pl. NW/87120 352-6563 (h)

Sara A. Breeden

8619 Animas Pl. NW/87120 352-0159 (h)

Bohannon  **Huston**

Courtyard 1
7500 Jefferson St. NE
Albuquerque, NM
87109-4335

CERTIFIED MAIL

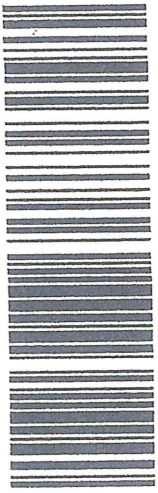

91 7199 9991 7031 0468 6155

Thomas Borst
1908 Selway Pl., NW
Albuquerque, NM 87120

PLACE STICKER AT TOP OF ENVELOPE TO THE RIGHT
OF THE RETURN ADDRESS. FOLD AT DOTTED LINE.

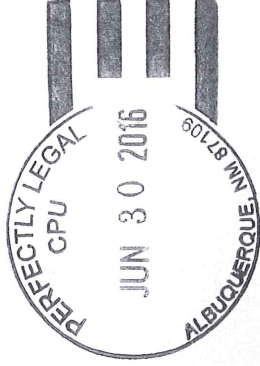

SENDER: COMPLETE THIS SECTION

- Complete items 1, 2, and 3. Also complete item 4 if Restricted Delivery is desired.
- Print your name and address on the reverse so that we can return the card to you.
- Attach this card to the back of the mailpiece, or on the front if space permits.

1. Article Addressed to:

Thomas Borst
1908 Selway Pl., NW
Albuquerque, NM 87120

2. Article Number
(Transfer from service label)
91 7199 9991 7031 0468 6155

COMPLETE THIS SECTION ON DELIVERY

A. Signature
 Agent
 Addressee

B. Received by (Printed Name) C. Date of Delivery

D. Is delivery address different from item 1? Yes
If YES, enter delivery address below: No

3. Service Type
 Certified Mail Express Mail
 Registered Return Receipt for Merchandise
 Insured Mail C.O.D.

4. Restricted Delivery? (Extra Fee) Yes

PS Form 3811, February 2004

Domestic Return Receipt

102595-02-M-1540

Bohannon  **Huston**

Courtyard 1
7500 Jefferson St. NE
Albuquerque, NM
87109-4335

CERTIFIED MAIL

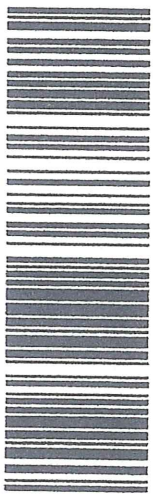

91 7199 9991 7031 0468 6148

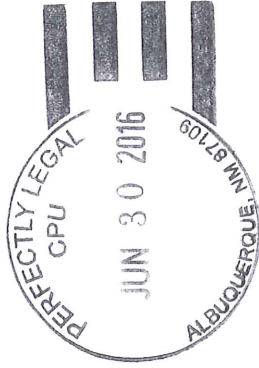

Sara A. Breeden
8619 Animas Pl., NW
Albuquerque, NM 87120

PLACE STICKER AT TOP OF ENVELOPE TO THE RIGHT OF THE RETURN ADDRESS. HOLD AT DOTTED LINE.

SENDER: COMPLETE THIS SECTION

- Complete items 1, 2, and 3. Also complete item 4 if Restricted Delivery is desired.
- Print your name and address on the reverse so that we can return the card to you.
- Attach this card to the back of the mailpiece, or on the front if space permits.

1. Article Addressed to:

Sara A. Breeden
8619 Animas Pl., NW
Albuquerque, NM 87120

2. Article Number
(Transfer from service label)

91 7199 9991 7031 0468 6148

PS Form 3811, February 2004

Domestic Return Receipt

102595-02-M-1540

COMPLETE THIS SECTION ON DELIVERY

A. Signature Agent
 Addressee

B. Received by (Printed Name) C. Date of Delivery

D. Is delivery address different from item 1? Yes
if YES, enter delivery address below: No

3. Service Type
 Certified Mail Express Mail
 Registered Return Receipt for Merchandise
 Insured Mail C.O.D.
 4. Restricted Delivery? (Extra Fee) Yes

CERTIFIED MAIL
RETURN RECEIPT REQUESTED

June 29, 2016

Sara A Breeden
8619 Animas PI NW
Albuquerque, NM 87120

Re: Subdivision Improvement Agreement Extension
Mirehaven Arroyo (Tract N-2-A-1; Del Webb @ Mirehaven Phase 1) DRB # 1006864

Dear Ms. Breeden:

The City of Albuquerque's Office of Neighborhood Coordination has informed us that you are a representative of a Neighborhood and/or Homeowner's Association associated with the above mentioned project site.

This letter is to advise you that Bohannon Huston, Inc., agent for Pulte Homes, is seeking an extension to the Subdivision Improvement Agreement. The site is located west of Tierra Pintada Blvd, south of the Petroglyph National Monument and north of the Mirehaven Parkway. The proposed project encompasses approximately 25.85 acres.

Please feel free to contact me if you have any questions regarding this matter or need information as to the date and time of the public hearing.

Sincerely,



Yolanda Padilla Moyer, P.E.
Senior Project Manager
Community Development & Planning

Enclosure
yjm

CERTIFIED MAIL
RETURN RECEIPT REQUESTED

June 29, 2016

Thomas Borst
1908 Selway Pl, NW
Albuquerque, NM 87120

Re: Subdivision Improvement Agreement Extension
Mirehaven Arroyo (Tract N-2-A-1; Del Webb @ Mirehaven Phase 1) DRB # 1006864

Dear Mr. Borst:

The City of Albuquerque's Office of Neighborhood Coordination has informed us that you are a representative of a Neighborhood and/or Homeowner's Association associated with the above mentioned project site.

This letter is to advise you that Bohannon Huston, Inc., agent for Pulte Homes, is seeking an extension to the Subdivision Improvement Agreement. The site is located west of Tierra Pintada Blvd, south of the Petroglyph National Monument and north of the Mirehaven Parkway. The proposed project encompasses approximately 25.85 acres.

Please feel free to contact me if you have any questions regarding this matter or need information as to the date and time of the public hearing.

Sincerely,

Yolanda Padilla Moyer, P.E.
Senior Project Manager
Community Development & Planning

Enclosure
yjm

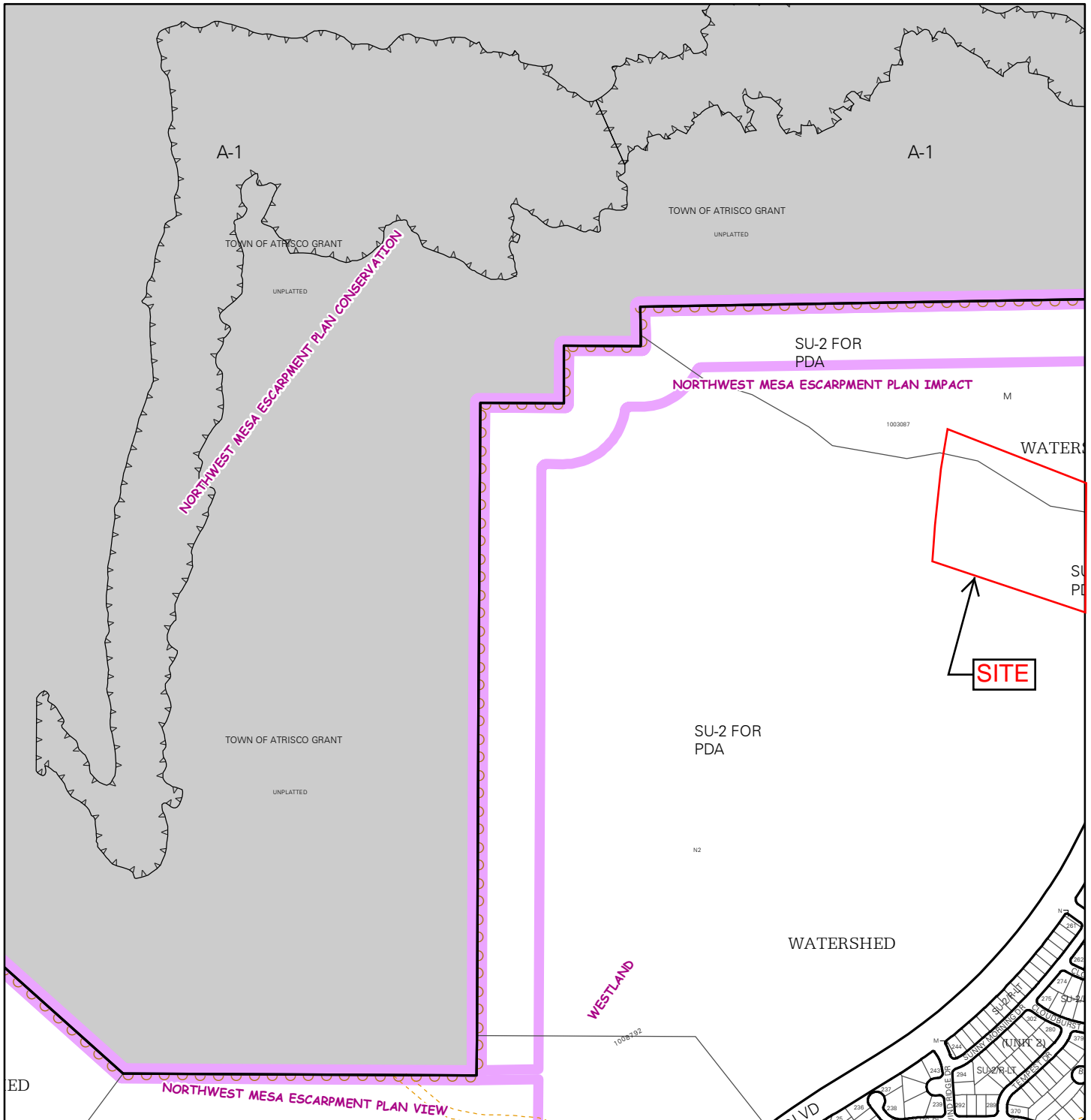

For more current information and details visit: <http://www.cabq.gov/gis>

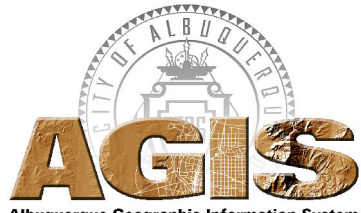

Map amended through: 6/7/2013

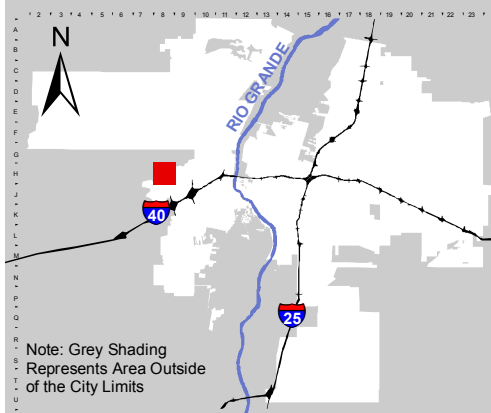

Note: Grey Shading Represents Area Outside of the City Limits

Zone Atlas Page:
H-08-Z

Selected Symbols

SECTOR PLANS	Escarpment
Design Overlay Zones	2 Mile Airport Zone
City Historic Zones	Airport Noise Contours
H-1 Buffer Zone	Wall Overlay Zone
Petroglyph Mon.	

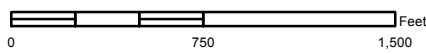

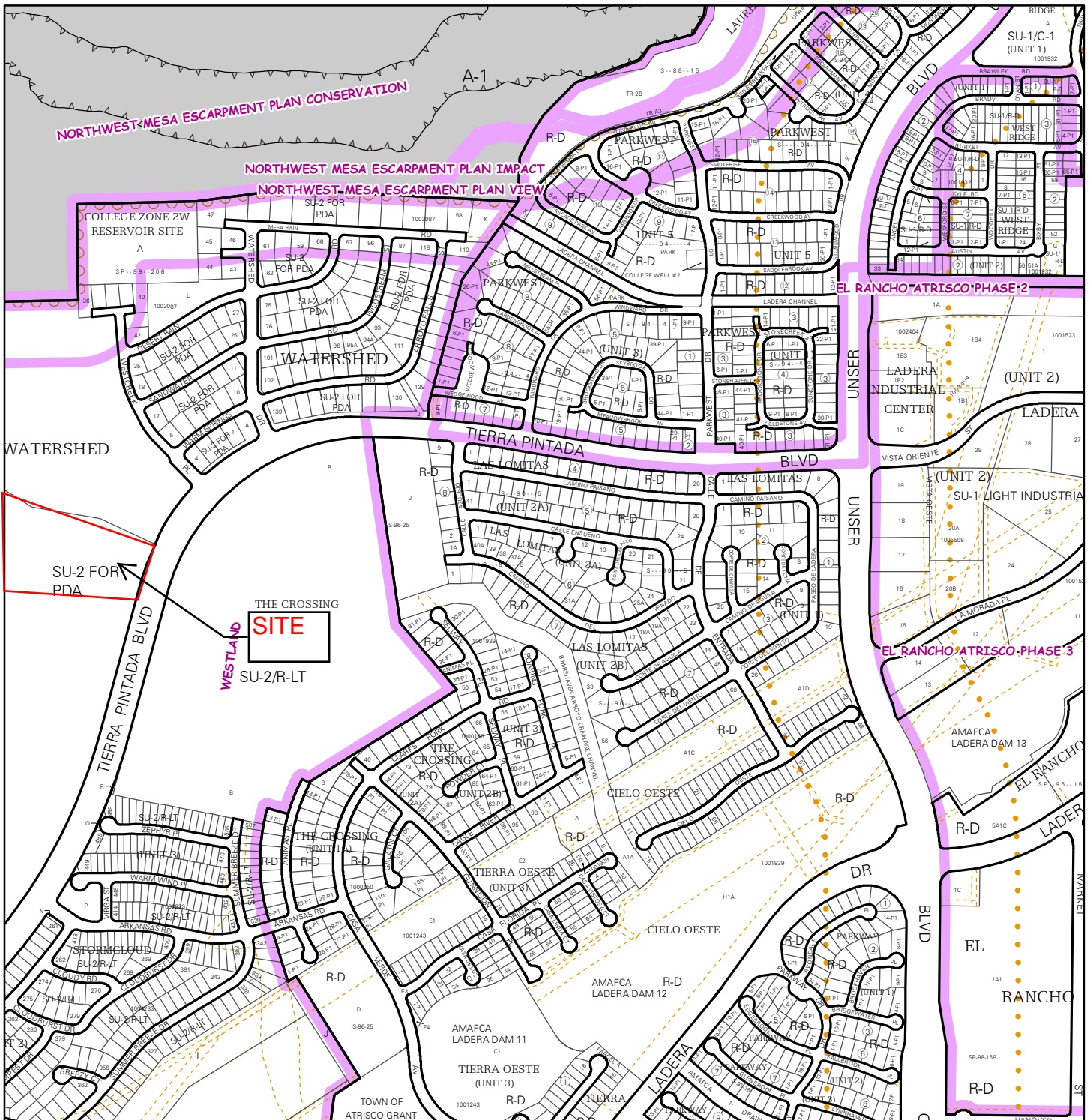

For more current information and details visit: <http://www.cabq.gov/gis>

