

SECTION B-B
SC: 1"=3'

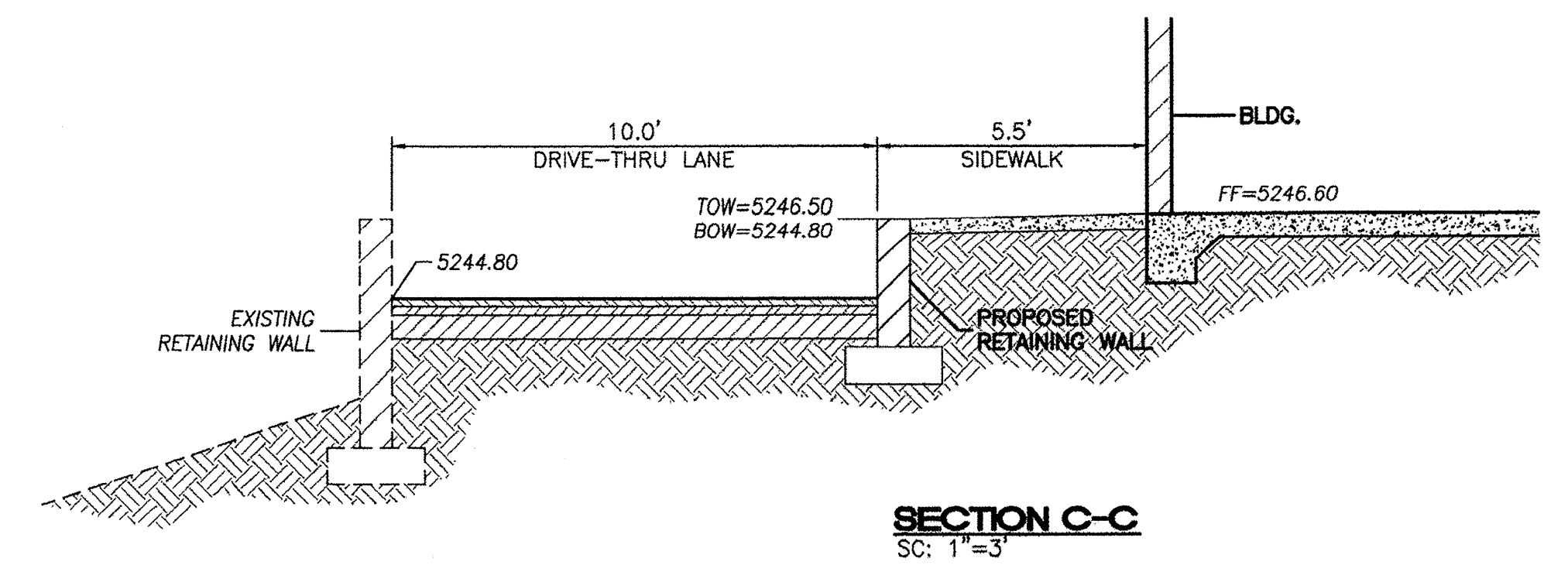

SECTION C-C
SC: 1"=3'

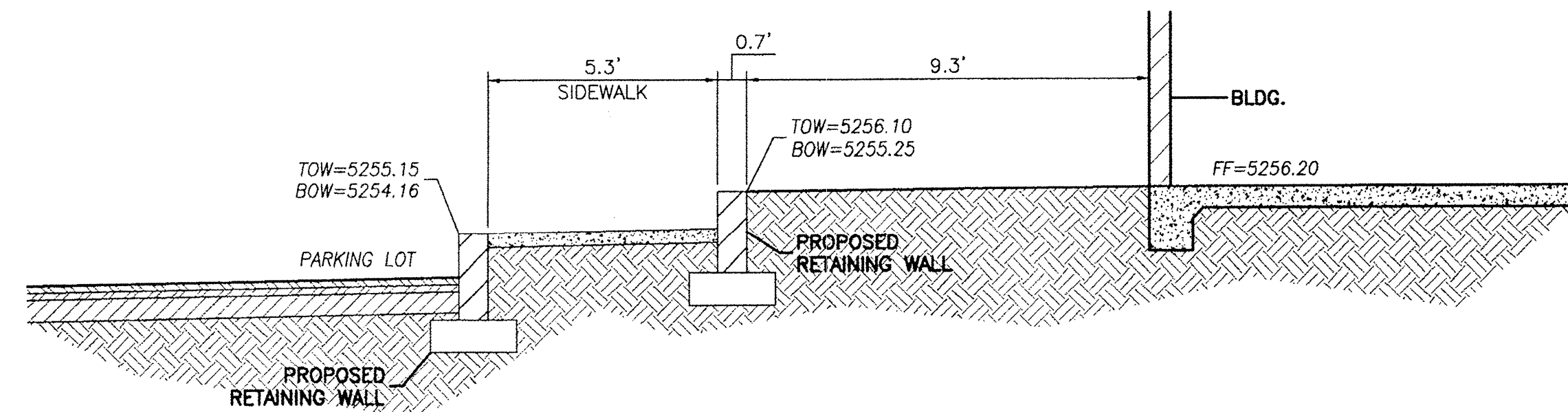

SECTION D-D
SC: 1"=3'

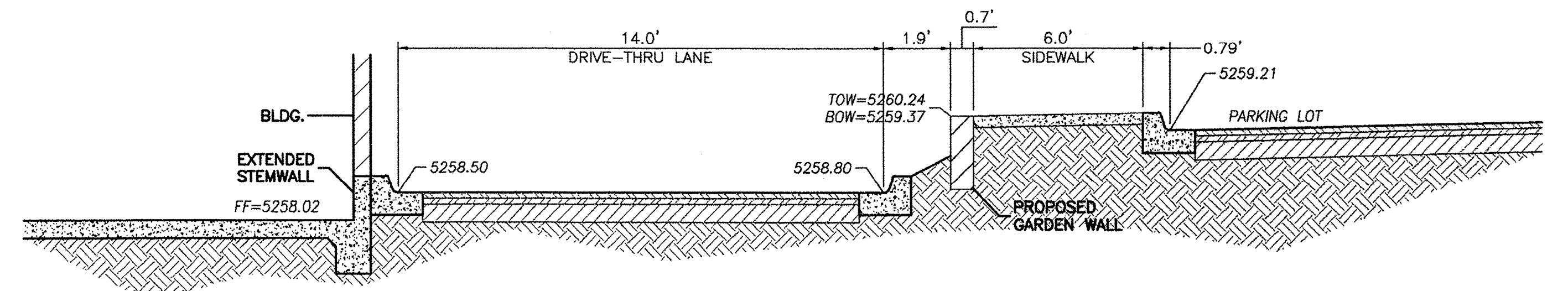

SECTION E-E
SC: 1"=3'

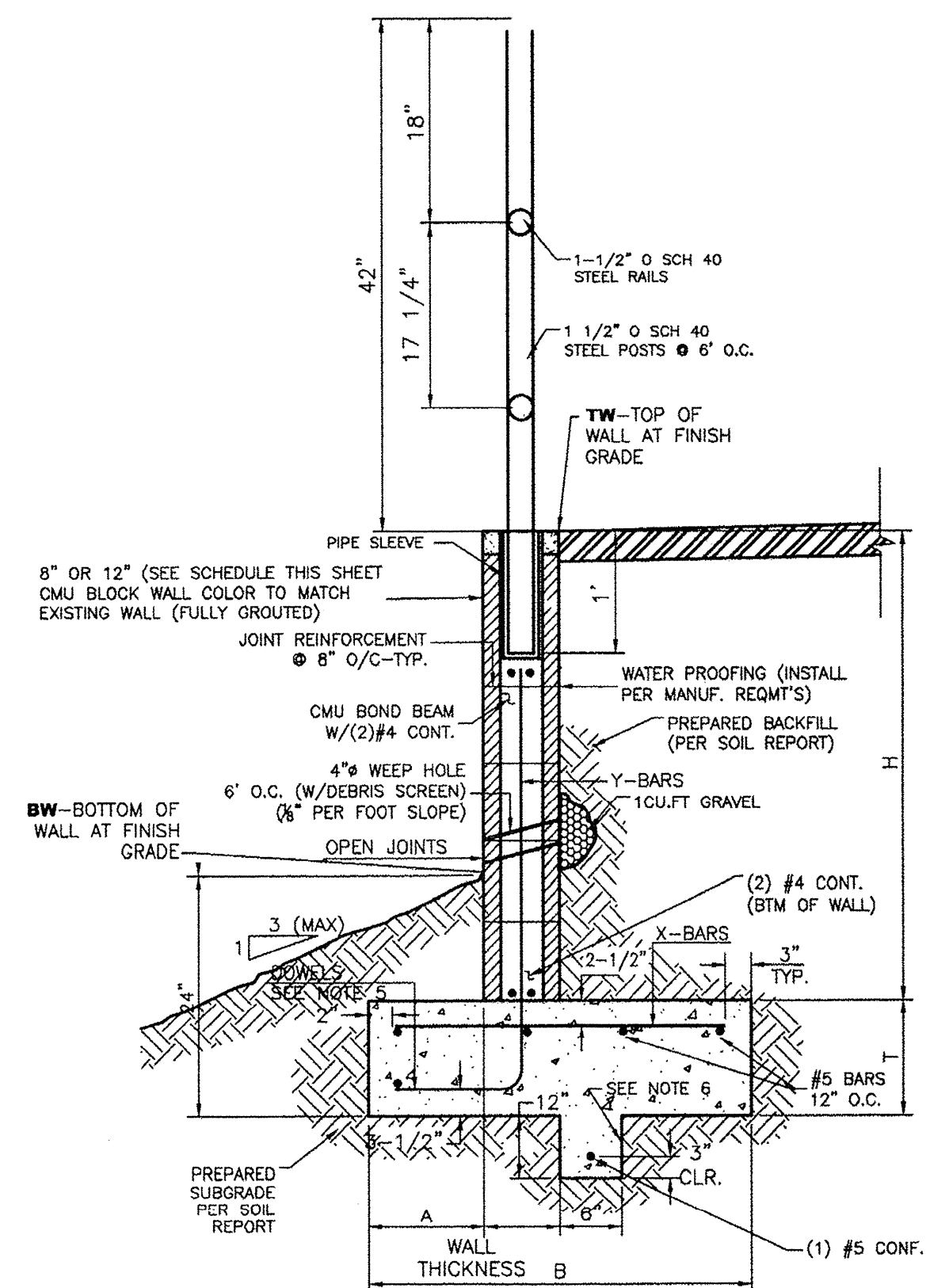

- RETAINING WALL DETAIL**
NTS
- $f_m = 1500$ PSI
 - SOIL ALLOWABLE 2000 PSF (VERIFY W/SOILS REPORT)
 - ACTIVE SOIL PRESSURE - 35 PSF/FT (VERIFY W/SOILS REPORT)
 - PASSIVE SOIL PRESSURE - 250 PSF/FT (VERIFY W/SOILS REPORT)
 - SOIL FRICTION FACTOR - 0.4 (VERIFY W/SOILS REPORT)

8 INCH REINFORCED CONCRETE MASONRY WALL

H	A	B	T	Y-BARS	X-BARS
ft.-in.	in.	ft.-in.	in.		
2'-0"	10"	2'-4"	10"	#4 @24" O.C.	#4 @24" O.C.
2'-8"	10"	2'-4"	10"	#4 @24" O.C.	#4 @24" O.C.
3'-4"	10"	2'-4"	10"	#4 @24" O.C.	#4 @24" O.C.
4'-0"	12"	2'-8"	10"	#4 @16" O.C.	#4 @24" O.C.
4'-8"	16"	3'-4"	12"	#5 @16" O.C.	#4 @18" O.C.
5'-4"	19"	3'-10"	12"	#5 @8" O.C.	#5 @24" O.C.
6'-0"	20"	4'-8"	12"	#5 @8" O.C.	#5 @24" O.C.

Y-BARS EDGE (2 1/2") FROM RETAINING FACE

12 INCH REINFORCED CONCRETE MASONRY WALL

H	A	B	T	Y-BARS	X-BARS
ft.-in.	in.	ft.-in.	in.		
5'-4"	16"	3'-8"	12"	#5 @16" O.C.	#5 @24" O.C.
6'-0"	19"	4'-2"	12"	#5 @8" O.C.	#5 @24" O.C.
6'-8"	21"	4'-6"	12"	#5 @8" O.C.	#5 @16" O.C.
7'-4"	23"	4'-10"	12"	#6 @8" O.C.	#6 @18" O.C.
8'-0"	26"	5'-4"	12"	#6 @8" O.C.	#6 @18" O.C.
8'-8"	28"	5'-8"	12"	#6 @8" O.C.	#6 @12" O.C.

Y-BARS EDGE (3") FROM RETAINING FACE

GENERAL NOTES:

1. ALL CONCRETE IS TO BE 4000 PSI @ 28 DAYS.
2. MINIMUM COMPACTION UNDER FOOTINGS IS TO BE 95% PER ASTM. D 1557 FOR A DEPTH OF 12" MOISTURE CONTENT IS TO BE ± 2.0%.
3. BACK FILL AGAINST WALLS IS TO BE HAND-PLACED AND COMPACTED.
4. ALL BARS ARE TO BE GRADE 60, ASTM 615.
5. DOWELS SHALL BE EQUAL IN SIZE AND SPACING TO Y-BARS, SHALL PROJECT A MINIMUM OF #4-24", #5-30", #6-36" INTO THE FILLED BLOCK CORES, AND SHALL EXTEND TO THE TOE OF THE FOOTING.
6. PROVIDE KEY FOR 8" AND 12" WALLS WHERE H EXCEEDS 6' USE EITHER EXPANSION JOINTS ON 20' CENTERS OR PLASTERS EVERY 16'.

	LOT 2 DEL NORTE PLAZA ALBUQUERQUE, NM	DRAWN BY pm
	GRADING AND DRAINAGE SECTIONS	DATE 4-10-17
TERRA WEST, LLC 5571 MIDWAY PARK PL NE ALBUQUERQUE, NEW MEXICO 87109 (505) 858-3100 www.tierrawestllc.com	DRAWING 2015064-GR	SHEET # GR-2
RONALD R. BOHANNAN P.E. #7868	JOB # 2015064	