

A NEW OFFICE / WAREHOUSE for
PURVIS INDUSTRIES
 3815 SINGER BLVD. N.E. ALBUQUERQUE, NEW MEXICO 87109

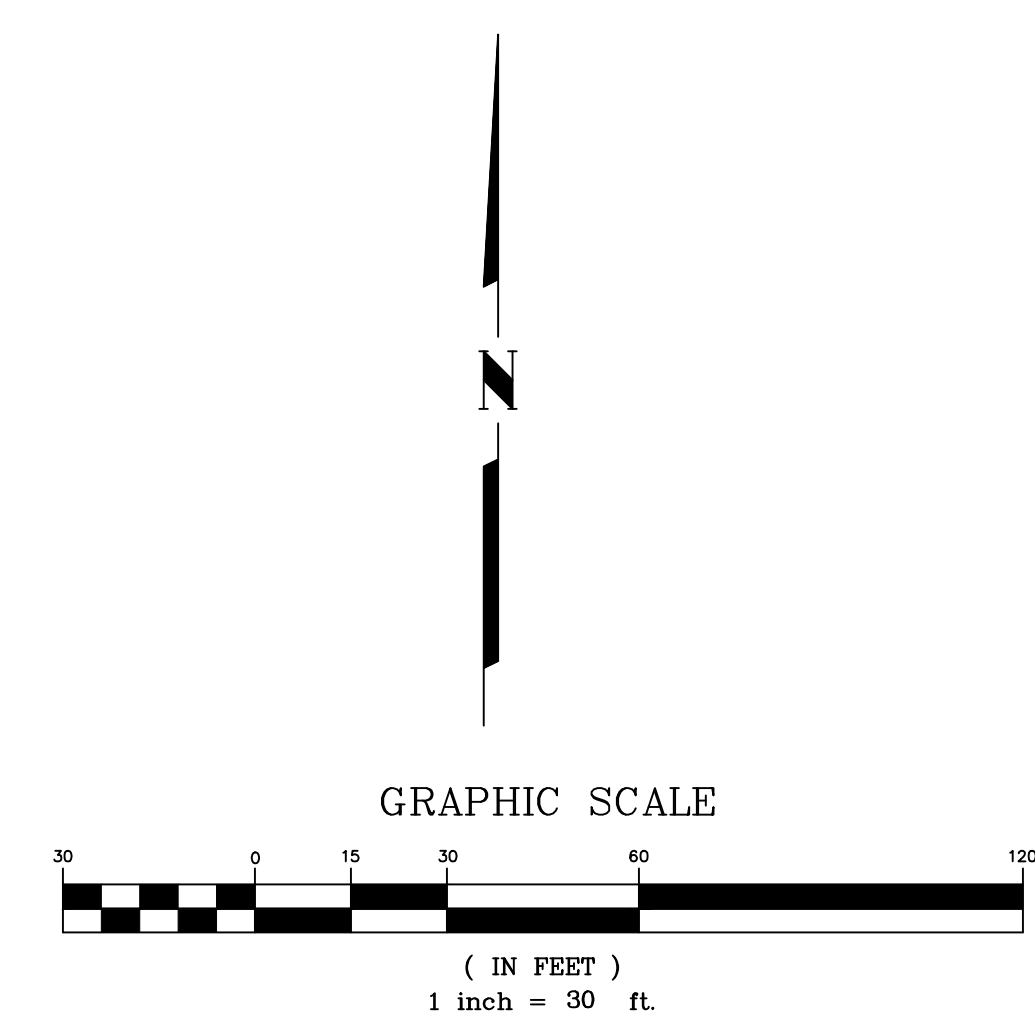
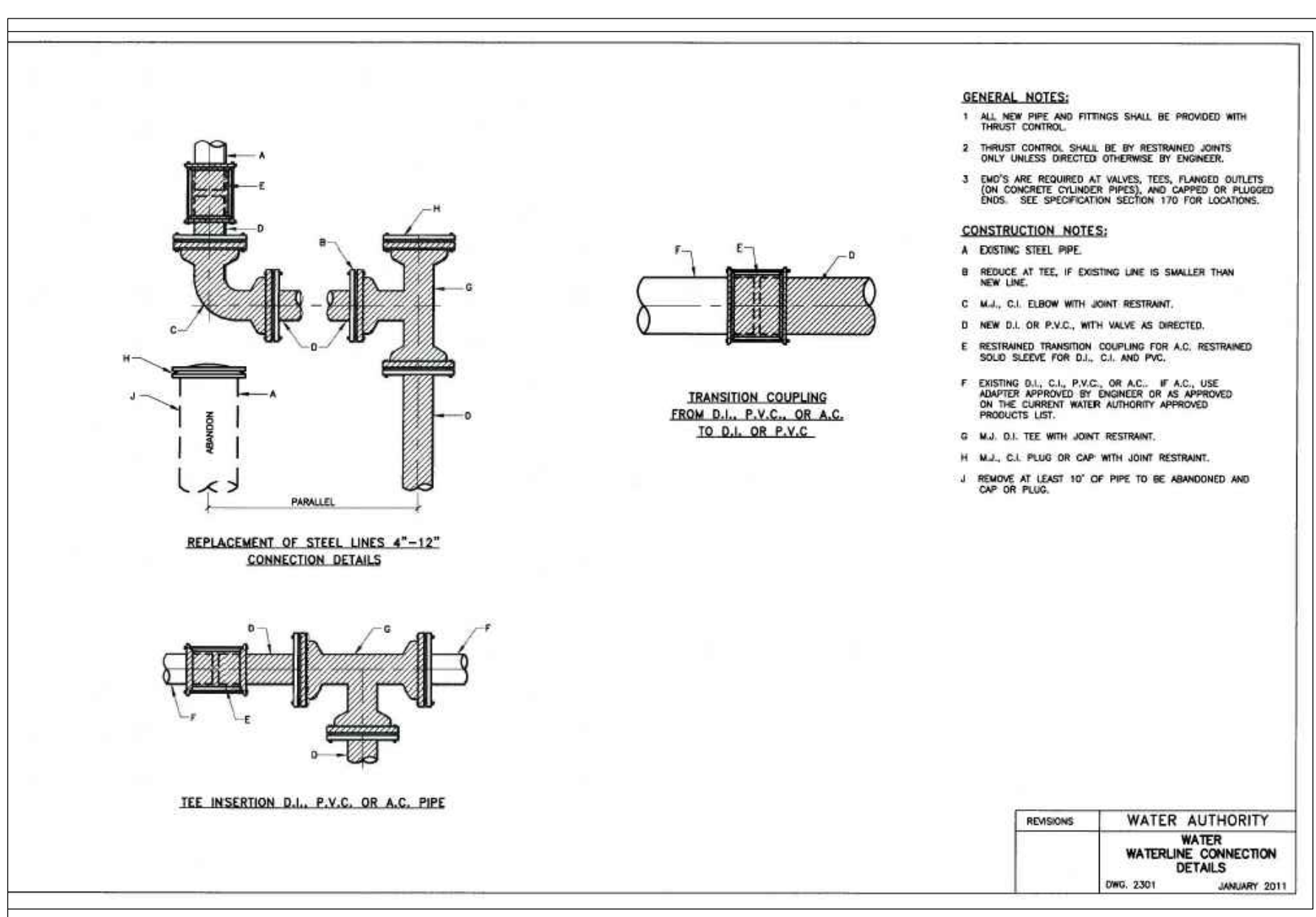
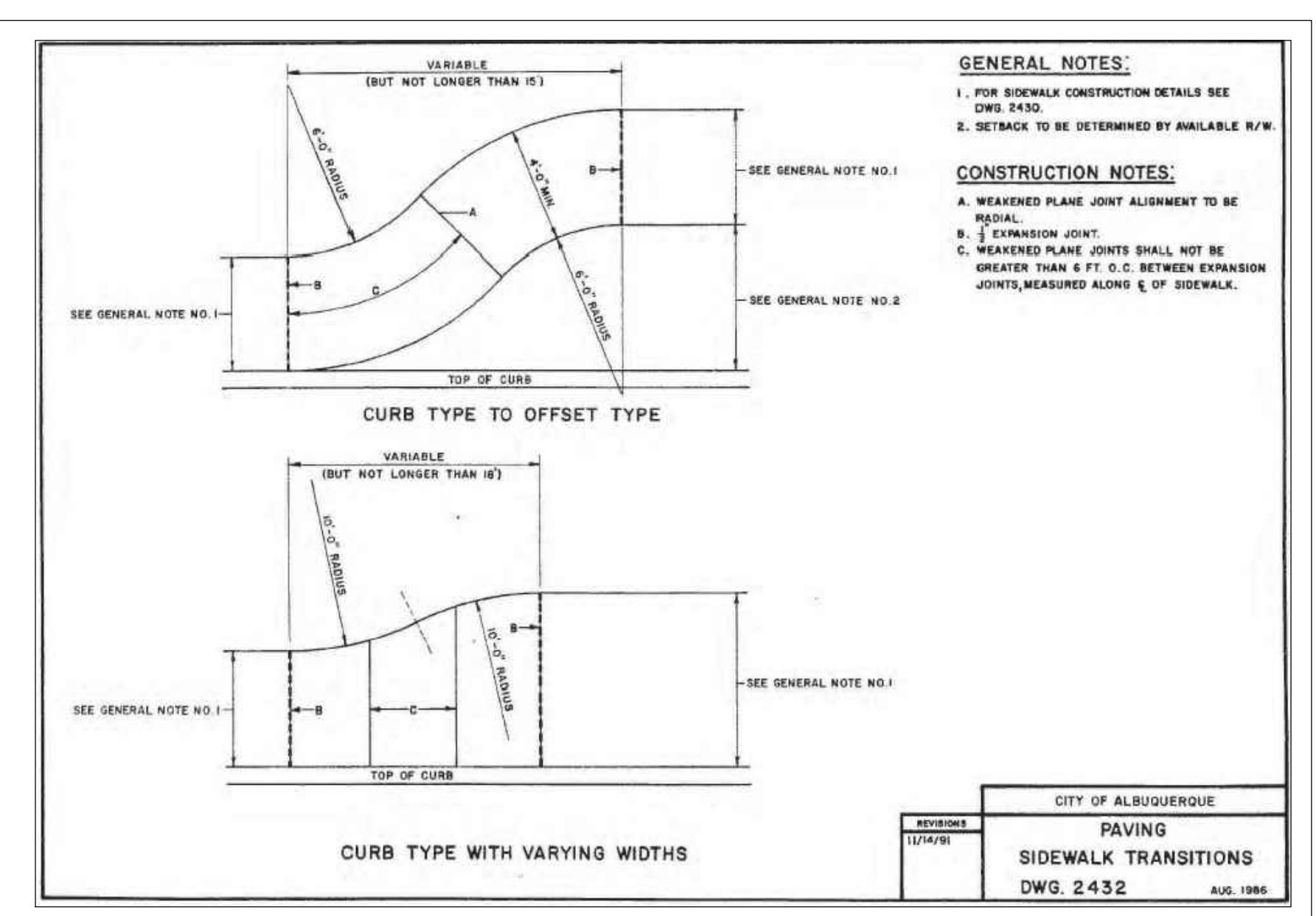

ISSUED FOR BUILDING PERMIT

ENGINEER'S SEAL HUGH W. FLOYD P.E. 16633	DETAILS JOB # 019-15-200
	FLOYD DEVELOPMENT SERVICES, LLC DEVELOPMENT, ENGINEERING, & WATERSHED CONSULTING 918 PINEHURST RD SE, SUITE 101 RIO RANCHO, NM 87124 HUGH@DEVELOPNM.COM 505-366-4187

OMISSION No. 15-121 DATE 09-2015 REV A - B - C - SHEET: C-4 4 OF 4
