

VICINITY MAP ZONE ATLAS PAGE M-22

SUBDIVISION NOTES

1. BEARINGS ARE BASED ON THE PLAT OF JUAN TABO HILLS, UNIT 1, FILED 12/22/2005 IN BK. 2005C, PG. 406. AND ARE NEW MEXICO STATE PLANE GRID (CENTRAL ZONE) (NAD 83).
2. RECORD BEARINGS AND DISTANCES ARE IN PARENTHESIS () WHERE RECORD DATA DIFFERS FROM MEASURED DATA.
3. DISTANCES ARE GROUND DISTANCES IN US FEET.
4. PLAT SHOWS ALL EASEMENTS OF RECORD.
5. GROSS AREA: 0.2744 ACRE, MORE OR LESS
6. NUMBER OF EXISTING LOTS: 2
7. NUMBER OF LOTS CREATED: 2

FLOOD NOTE

The property shown hereon is located in Zone X, (areas determined to be outside the 0.2% annual chance flood plain), according to the Flood Insurance Rate Map of Bernalillo County, New Mexico, Panel No. 35001C0367G, effective date September 26, 2008.

THIS IS TO CERTIFY THAT TAXES ARE CURRENT & PAID ON

UPC#: _____
 PROPERTY OWNER OF RECORD: _____
 BERNALILLO COUNTY TREASURER'S OFFICE: _____

LEGAL DESCRIPTION

Lots numbered Four (4) and Five (5) in Block numbered Seventeen (17) of JUAN TABO HILLS, UNIT 1, an Addition to the City of Albuquerque, Bernalillo County, New Mexico, as the same is shown and designated on the plat thereof, filed in the office of the County Clerk of Bernalillo County, New Mexico on December 22, 2005 in Book 2005C, Page 406, and being more particularly described as follows:

Beginning at the Southwest corner of the tract herein described, being identical to the Southwest corner of said Lot 5, whence the A.G.R.S. Station "7-M21" bears S46°19'25"W, 2,061.45 feet distant;
 Thence N35°00'00"W, 58.77 feet to a point;
 Thence N31°46'34"W, 58.80 feet to the northwest corner of said Lot 4;
 Thence N60°02'12"E, 106.86 feet to the northeast corner of said Lot 4, being a point on the west right-of-way line of Smarty Jones Street S.E.;
 Thence on a curve to the left having a radius of 1231.16 feet, a central angle of 05°02'13", through an arc of 108.23 feet and a chord which bears S32°28'54"E, 108.20 feet along said west right-of-way line of Smarty Jones Street S.E. to the southeast corner of said Lot 4;
 Thence S55°00'00"W, 105.00 to the point of beginning.
 Said tract containing 0.2744 acre, more or less.

FREE CONSENT

THE UNDERSIGNED OWNER(S) AND PROPRIETOR(S) OF THE PROPERTY DESCRIBED HEREON DO HEREBY CONSENT TO THE PLATTING OF SAID PROPERTY AS SHOWN HEREON AND THE SAME IS WITH THE FREE CONSENT AND IN ACCORDANCE WITH THEIR DESIRES AND DO HEREBY REPRESENT THAT THE UNDERSIGNED INDIVIDUALS ARE AUTHORIZED TO SO ACT. SAID OWNERS WARRANT THAT THEY HOLD AMONG THEM COMPLETE AND INDEFEASIBLE TITLE IN FEE SIMPLE TO THE LAND SUBDIVIDED.

[Signature]

KIM BROOKS, PRESIDENT, SUMMERTREE HOMES INC., OWNER OF LOTS 4 AND 5, BLOCK 17

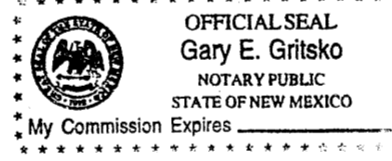

STATE OF NEW MEXICO)
 COUNTY OF BERNALILLO)

THIS INSTRUMENT WAS ACKNOWLEDGED BEFORE ME ON AUG 9, 2010.

BY: KIM BROOKS, PRESIDENT, SUMMERTREE HOMES INC.

MY COMMISSION EXPIRES: 7/27/2012

[Signature]
 NOTARY PUBLIC

County Clerk Recording Stamp

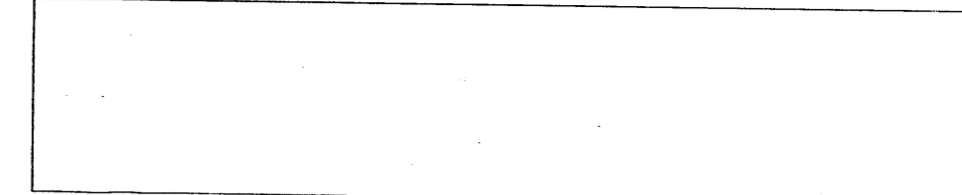

PLAT OF
 LOTS 4-A & 5-A, BLOCK 17
 JUAN TABO HILLS, UNIT 1
 in Section 34, T10N, R4E, NMPM
 City of Albuquerque
 Bernalillo County, New Mexico
 July 2010

PURPOSE OF PLAT

THE PURPOSE OF THIS PLAT IS TO ADJUST THE LOT LINE FROM TWO EXISTING LOTS, CREATING TWO NEW LOTS.

CITY DRB APPROVALS:

PROJECT NO. _____	APPLICATION NO. _____
<i>[Signature]</i> CITY SURVEYOR	<u>8-10-10</u> DATE
TRAFFIC ENGINEERING	DATE
PARKS & RECREATION DEPARTMENT	DATE
A.B.C.W.U.A.	DATE
A.M.A.F.C.A.	DATE
CITY ENGINEER	DATE
DRB CHAIRPERSON, PLANNING DEPARTMENT	DATE

SURVEYOR'S CERTIFICATION

I, Gary E. Gritsko, a duly qualified Registered Professional Land Surveyor under the laws of the State of New Mexico, do hereby certify that this plat and description were prepared by me or under my supervision, shows all easements as shown on the plat of record or made known to me by the owners and/or proprietors of the subdivision shown hereon, utility companies and other parties expressing an interest and meets the minimum requirements for monumentation and surveys of the Albuquerque Subdivision Ordinance, and further meets the Minimum Standards for Land Surveying in the State of New Mexico and is true and correct to the best of my knowledge and belief.

[Signature]
 Gary E. Gritsko
 New Mexico Professional Surveyor, 8686

AUG. 9, 2010
 Date



ALPHA PROFESSIONAL SURVEYING, INC.

P.O. BOX 46316, RIO RANCHO, NEW MEXICO 87174
 (505) 892-1076 FAX (505) 891-0471
 DRAWN BY: CS FILE NO: 10-083

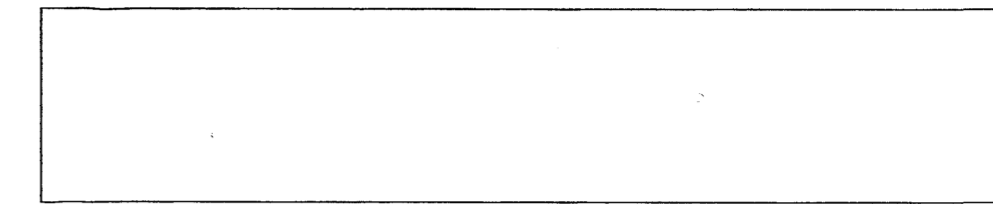

PLAT OF
 LOTS 4-A & 5-A, BLOCK 17
 JUAN TABO HILLS, UNIT 1
 in Section 34, T10N, R4E, NMPM
 City of Albuquerque
 Bernalillo County, New Mexico
 July 2010

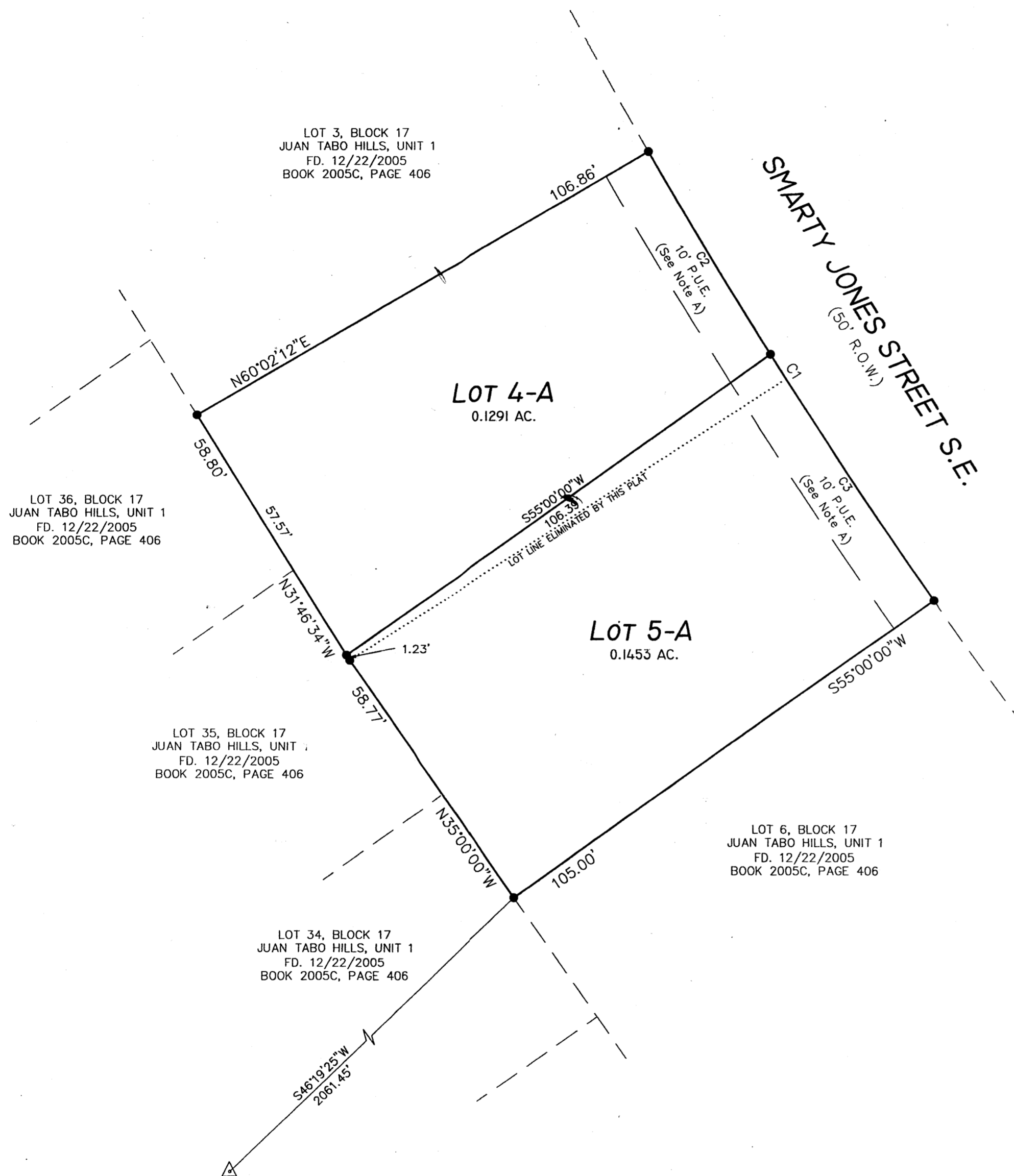

NOTE: SOLAR RESTRICTIONS

No property within the area of requested final plat shall at any time be subject to a deed restriction, covenant or binding agreement prohibiting solar collectors from being installed on buildings or erected on the lots or parcels within the area of proposed plat. The foregoing requirement shall be a condition to approval of this plat for subdivision.

EASEMENT NOTES:

A. 10' Public Utility Easements granted by the plat of Juan Tabo Hills, Unit 1, recorded on December 22, 2005 in Bk. 2005C, Pg. 406.

UTILITY APPROVALS

PUBLIC UTILITY EASEMENTS SHOWN ON THIS PLAT ARE GRANTED FOR THE COMMON AND JOINT USE OF:

A. PUBLIC SERVICE COMPANY OF NEW MEXICO (PNM) A NEW MEXICO CORPORATION, (PNM ELECTRIC) FOR INSTALLATION, MAINTENANCE, AND SERVICE OF OVERHEAD AND UNDERGROUND ELECTRICAL LINES, TRANSFORMERS, OTHER EQUIPMENT AND RELATED FACILITIES REASONABLY NECESSARY TO PROVIDE ELECTRICAL SERVICES.

B. NEW MEXICO GAS COMPANY FOR INSTALLATION, MAINTENANCE, AND SERVICE OF NATURAL GAS LINES, VALVES AND OTHER EQUIPMENT AND FACILITIES REASONABLY NECESSARY TO PROVIDE NATURAL GAS SERVICES.

C. QWEST COMMUNICATIONS FOR THE INSTALLATION, MAINTENANCE AND SERVICE OF SUCH LINES, CABLE, AND OTHER RELATED EQUIPMENT AND FACILITIES REASONABLY NECESSARY TO PROVIDE COMMUNICATION SERVICES.

D. COMCAST CABLE FOR THE INSTALLATION, MAINTENANCE AND SERVICE OF SUCH LINES, CABLE, AND OTHER RELATED EQUIPMENT AND FACILITIES REASONABLY NECESSARY TO PROVIDE CABLE TV SERVICES.

INCLUDED, IS THE RIGHT TO BUILD, REBUILD, CONSTRUCT, RECONSTRUCT, LOCATE, RELOCATE, CHANGE, REMOVE, MODIFY, RENEW, OPERATE, AND MAINTAIN FACILITIES FOR THE PURPOSES DESCRIBED ABOVE, TOGETHER WITH FREE ACCESS TO, FROM AND OVER SAID EASEMENTS, WITH THE RIGHT AND PRIVILEGE OF GOING UPON, OVER AND ACROSS ADJOINING LANDS OF GRANTOR FOR THE PURPOSE SET FORTH HEREIN AND WITH THE RIGHT TO UTILIZE THE RIGHT OF WAY AND EASMENT TO EXTEND SERVICES TO CUSTOMERS OF GRANTEE, INCLUDING SUFFICIENT WORKING AREA SPACE FOR ELECTRIC TRANSFORMERS, WITH THE RIGHT AND PRIVILEGE TO TRIM AND REMOVE TREES, SHRUBS OR BUSHES WHICH INTERFERE WITH THE PURPOSES SET FORTH HEREIN. NO BUILDING, SIGN, POOL (ABOVEGROUND OR SUBSURFACE), HOT TUB, CONCRETE OR WOOD POOL DECKING, OR OTHER STRUCTURES SHALL BE ERRECTED OR CONSTRUCTED ON SAID EASEMENTS NOR SHALL ANY WELL BE DRILLED OR OPERATED THEREON. PROPERTY OWNERS SHALL BE SOLELY RESPONSIBLE FOR CORRECTING ANY VIOLATIONS OF NATIONAL ELECTRICAL SAFETY CODE BY CONSTRUCTION OF POOL, DECKING, OR ANY STRUCTURES ADJACENT TO OR NEAR EASEMENTS SHOWN ON THIS PLAT.

EASEMENTS FOR ELECTRIC TRANSFORMERS/SWITCHGEARS, AS INSTALLED, SHALL EXTEND TEN (10) FEET IN FRONT OF TRANSFORMER/SWITCHGEAR DOORS AND FIVE (5) FEET ON EACH SIDE.

DISCLAIMER:
 IN APPROVING THIS PLAT, PUBLIC SERVICE COMPANY OF NEW MEXICO (PNM) AND NEW MEXICO GAS COMPANY (NMGC) DID NOT CONDUCT A TITLE SEARCH OF THE PROPERTIES SHOWN HEREON. CONSEQUENTLY, PNM AND NMGC DO NOT WAIVE OR RELEASE ANY EASEMENT OR EASEMENT RIGHTS WHICH MAY HAVE BEEN GRANTED BY PRIOR PLAT, REPLAT OR OTHER DOCUMENT AND WHICH ARE NOT SHOWN ON THIS PLAT.

EASEMENTS FOR ELECTRIC TRANSFORMERS/SWITCHGEARS, AS INSTALLED, SHALL EXTEND TEN FEET (10) IN FRONT OF TRANSFORMER/SWITCHGEAR DOORS AND FIVE FEET (5) ON EACH SIDE.

 PUBLIC SERVICE CO. OF NEW MEXICO DATE

 QWEST COMMUNICATIONS DATE

 NEW MEXICO GAS COMPANY DATE

 COMCAST CABLE DATE

AGRS STATION "7_M21"
 NM STATE PLANE COORDINATES
 N=1471683.328, E=1559637.958
 CENTRAL ZONE (NAD 83)
 G-G FACTOR: 0.999648202
 MAPPING ANGLE: -0°09'17.90"

MONUMENT LEGEND

- △ - FOUND CONTROL STATION AS NOTED
- - FOUND MONUMENT AS NOTED
- - SET 1/2" REBAR W/YELLOW PLASTIC CAP STAMPED "GRITSKO LS8686" UNLESS OTHERWISE NOTED

CURVE TABLE					
CURVE	LENGTH	RADIUS	CHORD BEARING	CHORD	DELTA
C1	108.23	1231.16	S32°28'54"E	108.20	05°02'13"
C2	48.21	1231.16	S31°05'06"E	48.21	02°14'37"
C3	60.02	1231.16	S33°36'13"E	60.02	02°47'36"

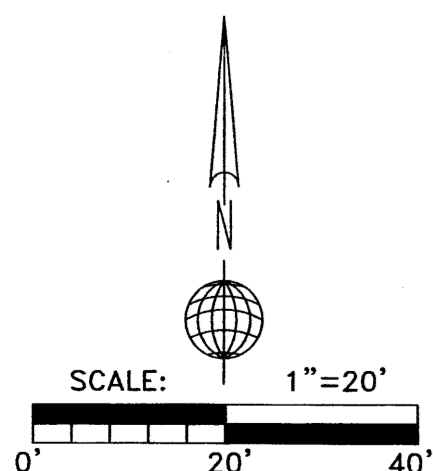

ALPHA PROFESSIONAL SURVEYING, INC.
 P.O. BOX 46316, RIO RANCHO, NEW MEXICO 87174
 PHONE (505) 892-1076 FAX (505) 891-0471
 DRAWN BY: CS FILE NO: 10-083

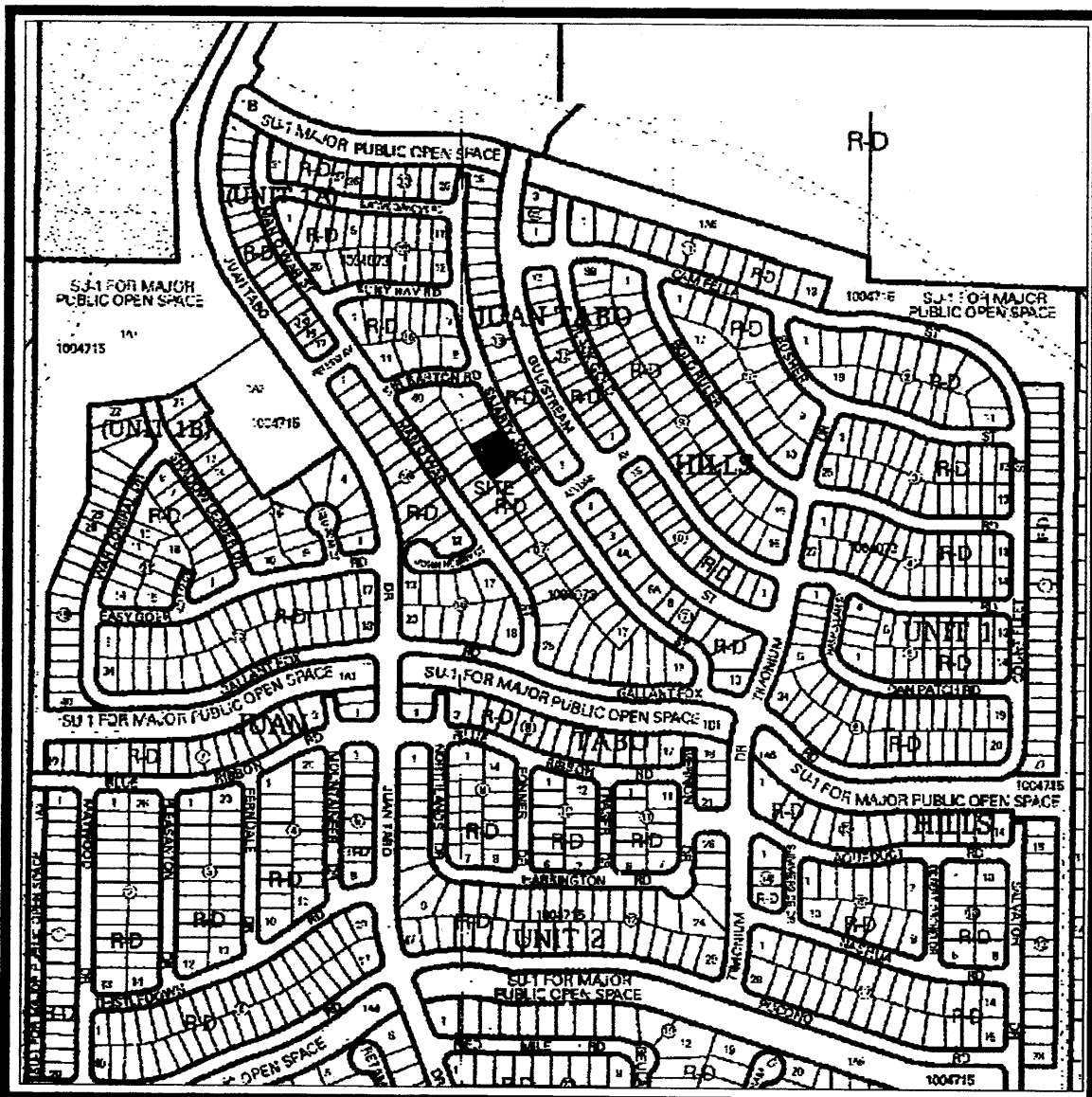

VICINITY MAP ZONE ATLAS PAGE M-22

SUBDIVISION NOTES

1. BEARINGS ARE BASED ON THE PLAT OF JUAN TABO HILLS, UNIT 1, FILED 12/22/2005 IN BK. 2005C, PG. 406. AND ARE NEW MEXICO STATE PLANE GRID (CENTRAL ZONE) (NAD 83).
2. RECORD BEARINGS AND DISTANCES ARE IN PARENTHESIS () WHERE RECORD DATA DIFFERS FROM MEASURED DATA.
3. DISTANCES ARE GROUND DISTANCES IN US FEET.
4. PLAT SHOWS ALL EASEMENTS OF RECORD.
5. GROSS AREA: 0.2744 ACRE, MORE OR LESS
6. NUMBER OF EXISTING LOTS: 2
7. NUMBER OF LOTS CREATED: 2

FLOOD NOTE

The property shown hereon is located in Zone X, (areas determined to be outside the 0.2% annual chance flood plain), according to the Flood Insurance Rate Map of Bernalillo County, New Mexico, Panel No. 35001C0367G, effective date September 26, 2008.

THIS IS TO CERTIFY THAT TAXES ARE CURRENT & PAID ON

UPC#: NEW 2010 15113
 PROPERTY OWNER OF RECORD:
HOMES BY KIM BROOKS INC
 BERNALILLO COUNTY TREASURER'S OFFICE:
8-20-10

LEGAL DESCRIPTION

Lots numbered Four (4) and Five (5) in Block numbered Seventeen (17) of JUAN TABO HILLS, UNIT 1, an Addition to the City of Albuquerque, Bernalillo County, New Mexico, as the same is shown and designated on the plat thereof, filed in the office of the County Clerk of Bernalillo County, New Mexico on December 22, 2005 in Book 2005C, Page 406, and being more particularly described as follows:

Beginning at the Southwest corner of the tract herein described, being identical to the Southwest corner of said Lot 5, whence the A.G.R.S. Station "7-M21" bears S46°19'25"W, 2,061.45 feet distant;
 Thence N35°00'00"W, 58.77 feet to a point;
 Thence N31°46'34"W, 58.80 feet to the northwest corner of said Lot 4;
 Thence N60°02'12"E, 106.86 feet to the northeast corner of said Lot 4, being a point on the west right-of-way line of Smarty Jones Street S.E.;
 Thence on a curve to the left having a radius of 1231.16 feet, a central angle of 05°02'13", through an arc of 108.23 feet and a chord which bears S32°28'54"E, 108.20 feet along said west right-of-way line of Smarty Jones Street S.E. to the southeast corner of said Lot 4;
 Thence S55°00'00"W, 105.00 to the point of beginning.
 Said tract containing 0.2744 acre, more or less.

FREE CONSENT

THE UNDERSIGNED OWNER(S) AND PROPRIETOR(S) OF THE PROPERTY DESCRIBED HEREON DO HEREBY CONSENT TO THE PLATTING OF SAID PROPERTY AS SHOWN HEREON AND THE SAME IS WITH THE FREE CONSENT AND IN ACCORDANCE WITH THEIR DESIRES AND DO HEREBY REPRESENT THAT THE UNDERSIGNED INDIVIDUALS ARE AUTHORIZED TO SO ACT. SAID OWNERS WARRANT THAT THEY HOLD AMONG THEM COMPLETE AND INDEFEASIBLE TITLE IN FEE SIMPLE TO THE LAND SUBDIVIDED.

[Signature]
 KIM BROOKS, PRESIDENT, HOMES BY KIM BROOKS, INC., OWNER OF LOTS 4 AND 5, BLOCK 17

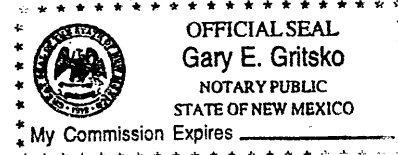

STATE OF NEW MEXICO)
 COUNTY OF BERNALILLO)

THIS INSTRUMENT WAS ACKNOWLEDGED BEFORE ME ON Aug 9, 2010.

BY: KIM BROOKS, PRESIDENT, HOMES BY KIM BROOKS INC.

MY COMMISSION EXPIRES: 7/27/2012

[Signature]
 GARY E. GRITSKO
 NOTARY PUBLIC

County Clerk Recording Stamp

DOC# 2010084140
 08/20/2010 03:28 PM Page: 1 of 2
 City: PLAT 2-512 00 B: 2010C P: 0102 M: Toulous Olivere, Bernalillo Cou

PLAT OF
 LOTS 4-A & 5-A, BLOCK 17
 JUAN TABO HILLS, UNIT 1
 in Section 34, T10N, R4E, NMPM
 City of Albuquerque
 Bernalillo County, New Mexico
 July 2010

PURPOSE OF PLAT

THE PURPOSE OF THIS PLAT IS TO ADJUST THE LOT LINE FROM TWO EXISTING LOTS, CREATING TWO NEW LOTS.

CITY DRB APPROVALS:

PROJECT NO. <u>1008454</u>	APPLICATION NO. <u>10DRB-70218</u>
<u>[Signature]</u> CITY SURVEYOR	<u>8-10-10</u> DATE
<u>[Signature]</u> TRAFFIC ENGINEERING	<u>08-18-10</u> DATE
<u>[Signature]</u> PARKS & RECREATION DEPARTMENT	<u>8-18-10</u> DATE
<u>Allan Pater</u> A.B.C.W.U.A.	<u>08/18/10</u> DATE
<u>Bradley A. Bingham</u> A.M.A.F.C.A.	<u>8/18/10</u> DATE
<u>Bradley A. Bingham</u> CITY ENGINEER	<u>8/18/10</u> DATE
<u>[Signature]</u> DRB CHAIRPERSON, PLANNING DEPARTMENT	<u>8/19/10</u> DATE

SURVEYOR'S CERTIFICATION

I, Gary E. Gritsko, a duly qualified Registered Professional Land Surveyor under the laws of the State of New Mexico, do hereby certify that this plat and description were prepared by me or under my supervision, shows all easements as shown on the plat of record or made known to me by the owners and/or proprietors of the subdivision shown hereon, utility companies and other parties expressing an interest and meets the minimum requirements for monumentation and surveys of the Albuquerque Subdivision Ordinance, and further meets the Minimum Standards for Land Surveying in the State of New Mexico and is true and correct to the best of my knowledge and belief.

[Signature]
 Gary E. Gritsko
 New Mexico Professional Surveyor, 8686

Aug. 9, 2010
 Date



ALPHA PROFESSIONAL SURVEYING, INC.

P.O. BOX 46316, RIO RANCHO, NEW MEXICO 87174
 (505) 892-1076 FAX (505) 891-0471
 DRAWN BY: CS FILE NO: 10-083

DOCH 2010084140
 09/20/2010 03:29 PM Page: 2 of 2
 PLAT R:\$12.00 B: 2010C P: 0102 M: Toulous Olivere, Bernalillo Cou

PLAT OF
 LOTS 4-A & 5-A, BLOCK 17
 JUAN TABO HILLS, UNIT 1
 in Section 34, T10N, R4E, NMPM
 City of Albuquerque
 Bernalillo County, New Mexico
 July 2010

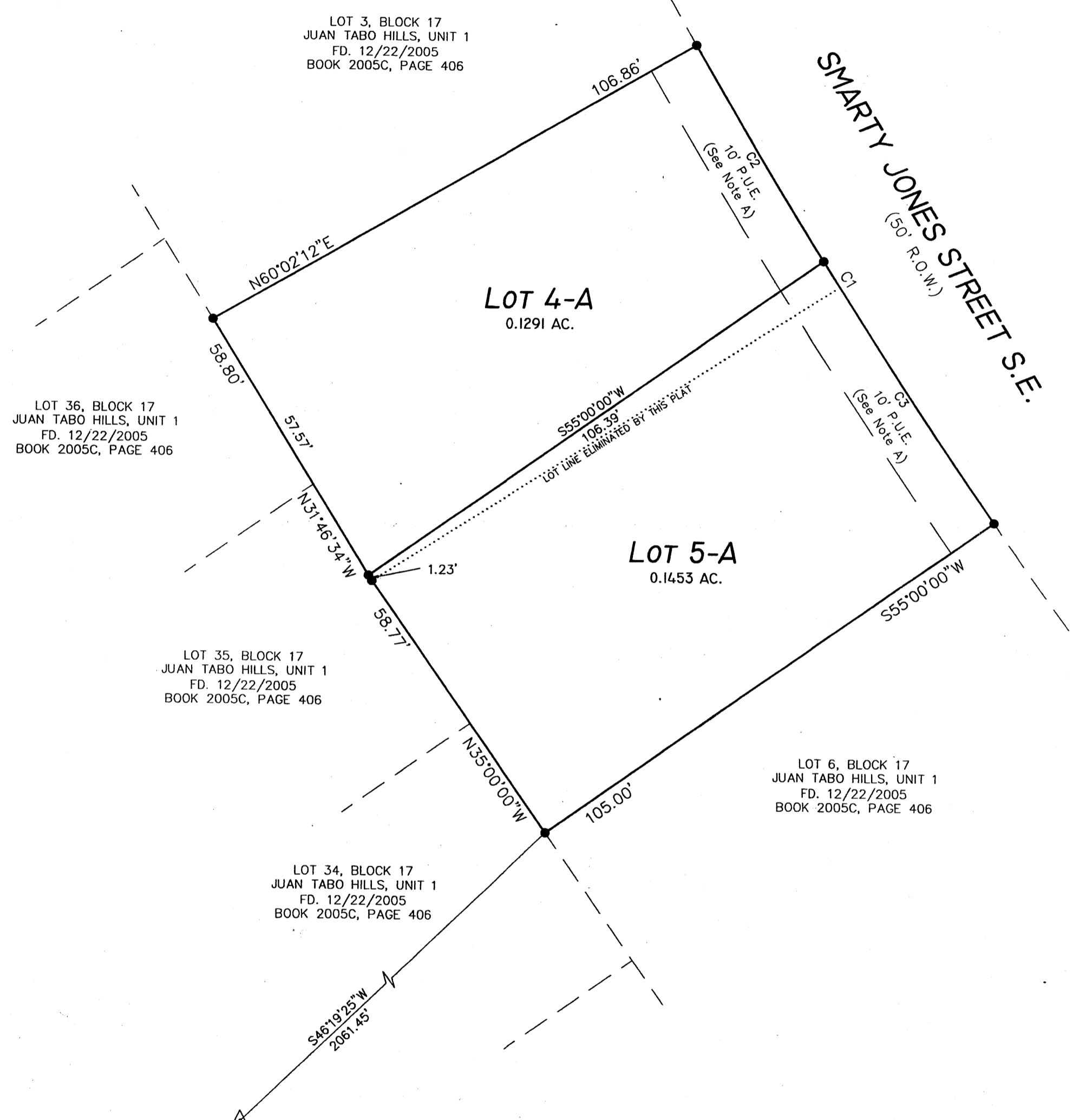

NOTE: SOLAR RESTRICTIONS

No property within the area of requested final plat shall at any time be subject to a deed restriction, covenant or binding agreement prohibiting solar collectors from being installed on buildings or erected on the lots or parcels within the area of proposed plat. The foregoing requirement shall be a condition to approval of this plat for subdivision.

EASEMENT NOTES:

A. 10' Public Utility Easements granted by the plat of Juan Tabo Hills, Unit 1, recorded on December 22, 2005 in Bk. 2005C, Pg. 406.

UTILITY APPROVALS

PUBLIC UTILITY EASEMENTS SHOWN ON THIS PLAT ARE GRANTED FOR THE COMMON AND JOINT USE OF:

- A. PUBLIC SERVICE COMPANY OF NEW MEXICO (PNM) A NEW MEXICO CORPORATION, (PNM ELECTRIC) FOR INSTALLATION, MAINTENANCE, AND SERVICE OF OVERHEAD AND UNDERGROUND ELECTRICAL LINES, TRANSFORMERS, OTHER EQUIPMENT AND RELATED FACILITIES REASONABLY NECESSARY TO PROVIDE ELECTRICAL SERVICES.
- B. NEW MEXICO GAS COMPANY FOR INSTALLATION, MAINTENANCE, AND SERVICE OF NATURAL GAS LINES, VALVES AND OTHER EQUIPMENT AND FACILITIES REASONABLY NECESSARY TO PROVIDE NATURAL GAS SERVICES.
- C. QWEST COMMUNICATIONS FOR THE INSTALLATION, MAINTENANCE AND SERVICE OF SUCH LINES, CABLE, AND OTHER RELATED EQUIPMENT AND FACILITIES REASONABLY NECESSARY TO PROVIDE COMMUNICATION SERVICES.
- D. COMCAST CABLE FOR THE INSTALLATION, MAINTENANCE AND SERVICE OF SUCH LINES, CABLE, AND OTHER RELATED EQUIPMENT AND FACILITIES REASONABLY NECESSARY TO PROVIDE CABLE TV SERVICES.

INCLUDED, IS THE RIGHT TO BUILD, REBUILD, CONSTRUCT, RECONSTRUCT, LOCATE, RELOCATE, CHANGE, REMOVE, MODIFY, RENEW, OPERATE, AND MAINTAIN FACILITIES FOR THE PURPOSES DESCRIBED ABOVE, TOGETHER WITH FREE ACCESS TO, FROM AND OVER SAID EASEMENTS, WITH THE RIGHT AND PRIVILEGE OF GOING UPON, OVER AND ACROSS ADJOINING LANDS OF GRANTOR FOR THE PURPOSE SET FORTH HEREIN AND WITH THE RIGHT TO UTILIZE THE RIGHT OF WAY AND EASMENT TO EXTEND SERVICES TO CUSTOMERS OF GRANTEE, INCLUDING SUFFICIENT WORKING AREA SPACE FOR ELECTRIC TRANSFORMERS, WITH THE RIGHT AND PRIVILEGE TO TRIM AND REMOVE TREES, SHRUBS OR BUSHES WHICH INTERFERE WITH THE PURPOSES SET FORTH HEREIN. NO BUILDING, SIGN, POOL (ABOVEGROUND OR SUBSURFACE), HOT TUB, CONCRETE OR WOOD POOL DECKING, OR OTHER STRUCTURES SHALL BE ERRECTED OR CONSTRUCTED ON SAID EASEMENTS NOR SHALL ANY WELL BE DRILLED OR OPERATED THEREON. PROPERTY OWNERS SHALL BE SOLELY RESPONSIBLE FOR CORRECTING ANY VIOLATIONS OF NATIONAL ELECTRICAL SAFETY CODE BY CONSTRUCTION OF POOL, DECKING, OR ANY STRUCTURES ADJACENT TO OR NEAR EASEMENTS SHOWN ON THIS PLAT.

EASEMENTS FOR ELECTRIC TRANSFORMERS/SWITCHGEARS, AS INSTALLED, SHALL EXTEND TEN (10) FEET IN FRONT OF TRANSFORMER/SWITCHGEAR DOORS AND FIVE (5) FEET ON EACH SIDE.

DISCLAIMER:
 IN APPROVING THIS PLAT, PUBLIC SERVICE COMPANY OF NEW MEXICO (PNM) AND NEW MEXICO GAS COMPANY (NMGC) DID NOT CONDUCT A TITLE SEARCH OF THE PROPERTIES SHOWN HEREON. CONSEQUENTLY, PNM AND NMGC DO NOT WAIVE OR RELEASE ANY EASEMENT OR EASEMENT RIGHTS WHICH MAY HAVE BEEN GRANTED BY PRIOR PLAT, REPLAT OR OTHER DOCUMENT AND WHICH ARE NOT SHOWN ON THIS PLAT.

EASEMENTS FOR ELECTRIC TRANSFORMERS/SWITCHGEARS, AS INSTALLED, SHALL EXTEND TEN FEET (10') IN FRONT OF TRANSFORMER/SWITCHGEAR DOORS AND FIVE FEET (5') ON EACH SIDE.

NA PUBLIC SERVICE CO. OF NEW MEXICO	DATE
<i>Alabek Ramirez</i> QWEST COMMUNICATIONS	08-10-10 DATE
<i>[Signature]</i> NEW MEXICO GAS COMPANY	8-17-2010 DATE
<i>Robert Mautz</i> COMCAST CABLE	8-17-10 DATE

AGRS STATION "7_M21"
 NM STATE PLANE COORDINATES
 N=1471683.328, E=1559637.958
 CENTRAL ZONE (NAD 83)
 G-G FACTOR: 0.999648202
 MAPPING ANGLE: -0°09'17.90"

MONUMENT LEGEND

- △ - FOUND CONTROL STATION AS NOTED
- - FOUND MONUMENT AS NOTED
- - SET 1/2" REBAR W/YELLOW PLASTIC CAP STAMPED "GRITSKO LS8686" UNLESS OTHERWISE NOTED

CURVE TABLE					
CURVE	LENGTH	RADIUS	CHORD BEARING	CHORD	DELTA
C1	108.23	1231.16	S32°28'54"E	108.20	05°02'13"
C2	48.21	1231.16	S31°05'06"E	48.21	02°14'37"
C3	60.02	1231.16	S33°36'13"E	60.02	02°47'36"

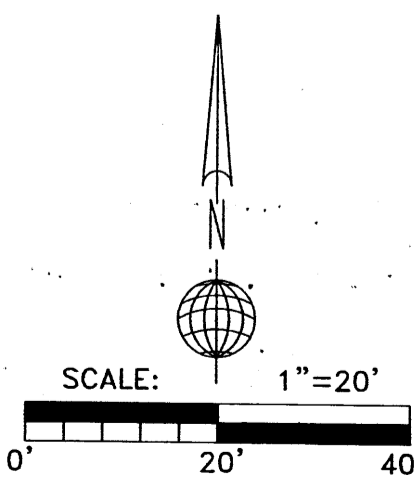

ALPHA PROFESSIONAL SURVEYING, INC.
 P.O. BOX 46316, RIO RANCHO, NEW MEXICO 87174
 PHONE (505) 892-1076 FAX (505) 891-0471
 DRAWN BY: CS FILE NO: 10-083

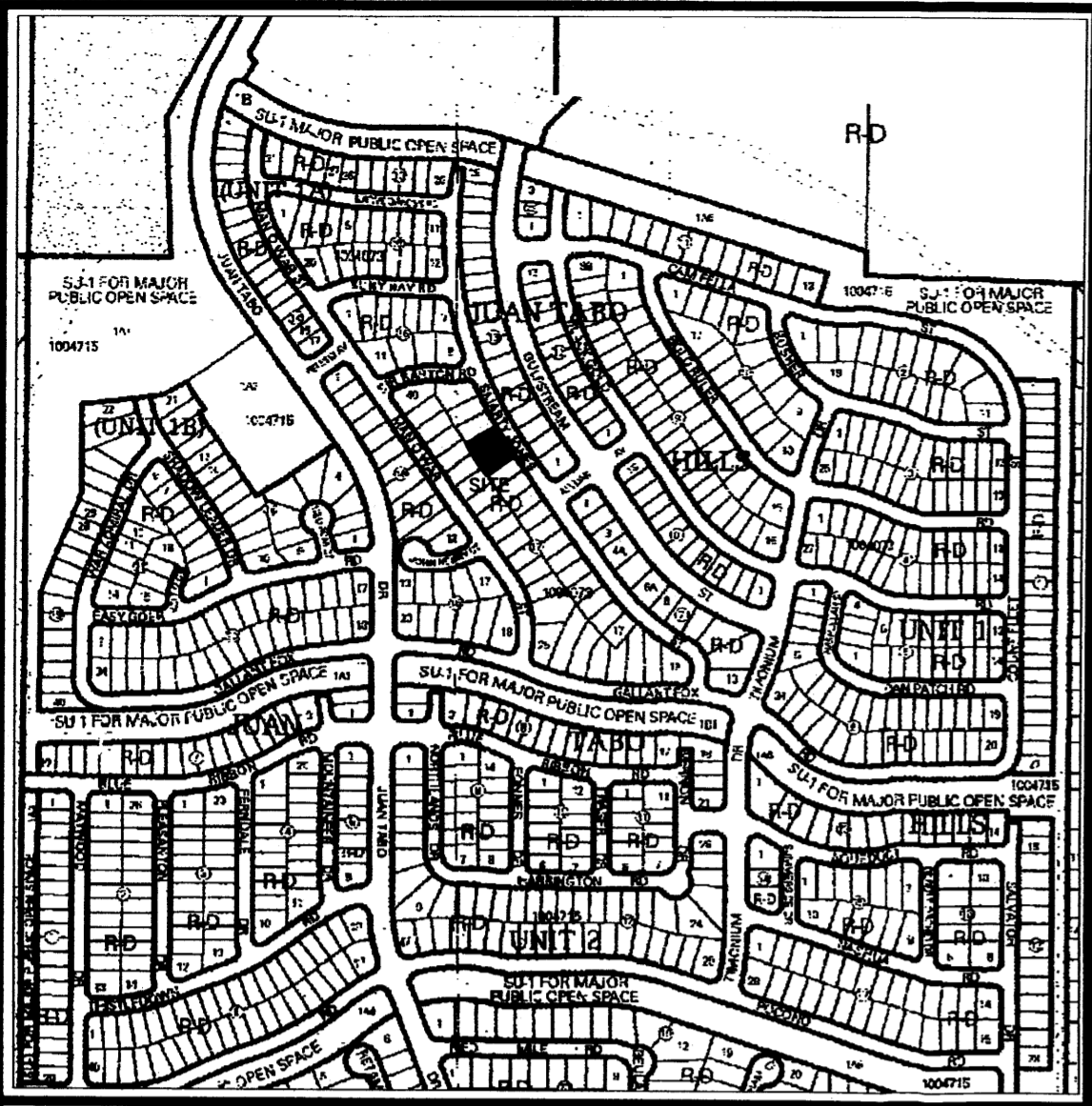

VICINITY MAP ZONE ATLAS PAGE M-22

SUBDIVISION NOTES

1. BEARINGS ARE BASED ON THE PLAT OF JUAN TABO HILLS, UNIT 1, FILED 12/22/2005 IN BK. 2005C, PG. 406. AND ARE NEW MEXICO STATE PLANE GRID (CENTRAL ZONE) (NAD 83).
2. RECORD BEARINGS AND DISTANCES ARE IN PARENTHESIS () WHERE RECORD DATA DIFFERS FROM MEASURED DATA.
3. DISTANCES ARE GROUND DISTANCES IN US FEET.
4. PLAT SHOWS ALL EASEMENTS OF RECORD.
5. GROSS AREA: 0.2744 ACRE, MORE OR LESS
6. NUMBER OF EXISTING LOTS: 2
7. NUMBER OF LOTS CREATED: 2

FLOOD NOTE

The property shown hereon is located in Zone X, (areas determined to be outside the 0.2% annual chance flood plain), according to the Flood Insurance Rate Map of Bernalillo County, New Mexico, Panel No. 35001C0367G, effective date September 26, 2008.

THIS IS TO CERTIFY THAT TAXES ARE CURRENT & PAID ON
 UPC#: _____
 PROPERTY OWNER OF RECORD: _____
 BERNALILLO COUNTY TREASURER'S OFFICE: _____

LEGAL DESCRIPTION

Lots numbered Four (4) and Five (5) in Block numbered Seventeen (17) of JUAN TABO HILLS, UNIT 1, an Addition to the City of Albuquerque, Bernalillo County, New Mexico, as the same is shown and designated on the plat thereof, filed in the office of the County Clerk of Bernalillo County, New Mexico on December 22, 2005 in Book 2005C, Page 406, and being more particularly described as follows:

Beginning at the Southwest corner of the tract herein described, being identical to the Southwest corner of said Lot 5, whence the A.G.R.S. Station "7-M21" bears S46°19'25"W, 2,061.45 feet distant;
 Thence N35°00'00"W, 58.77 feet to a point;
 Thence N31°46'34"W, 58.80 feet to the northwest corner of said Lot 4;
 Thence N60°02'12"E, 106.86 feet to the northeast corner of said Lot 4, being a point on the west right-of-way line of Smarty Jones Street S.E.;
 Thence on a curve to the left having a radius of 1231.16 feet, a central angle of 05°02'13", through an arc of 108.23 feet and a chord which bears S32°28'54"E, 108.20 feet along said west right-of-way line of Smarty Jones Street S.E. to the southeast corner of said Lot 4;
 Thence S55°00'00"W, 105.00 to the point of beginning.
 Said tract containing 0.2744 acre, more or less.

FREE CONSENT

THE UNDERSIGNED OWNER(S) AND PROPRIETOR(S) OF THE PROPERTY DESCRIBED HEREON DO HEREBY CONSENT TO THE PLATTING OF SAID PROPERTY AS SHOWN HEREON AND THE SAME IS WITH THE FREE CONSENT AND IN ACCORDANCE WITH THEIR DESIRES AND DO HEREBY REPRESENT THAT THE UNDERSIGNED INDIVIDUALS ARE AUTHORIZED TO SO ACT. SAID OWNERS WARRANT THAT THEY HOLD AMONG THEM COMPLETE AND INDEFEASIBLE TITLE IN FEE SIMPLE TO THE LAND SUBDIVIDED.

[Signature]

KIM BROOKS, PRESIDENT, SUMMERTREE HOMES INC, OWNER OF LOTS 4 AND 5, BLOCK 17

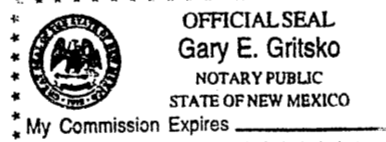

STATE OF NEW MEXICO)
 COUNTY OF BERNALILLO)

THIS INSTRUMENT WAS ACKNOWLEDGED BEFORE ME ON Aug 9, 2010.

BY: KIM BROOKS, PRESIDENT, SUMMERTREE HOMES INC.

MY COMMISSION EXPIRES: 7/27/2012

[Signature]
 Gary E. Gritsko
 NOTARY PUBLIC

County Clerk Recording Stamp

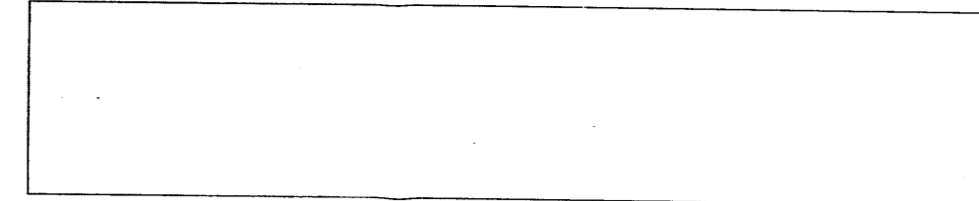

PLAT OF
 LOTS 4-A & 5-A, BLOCK 17
 JUAN TABO HILLS, UNIT 1
 in Section 34, T10N, R4E, NMPM
 City of Albuquerque
 Bernalillo County, New Mexico
 July 2010

PURPOSE OF PLAT

THE PURPOSE OF THIS PLAT IS TO ADJUST THE LOT LINE FROM TWO EXISTING LOTS, CREATING TWO NEW LOTS.

CITY DRB APPROVALS:

PROJECT NO. _____	APPLICATION NO. _____
<i>[Signature]</i>	<u>8-10-10</u>
CITY SURVEYOR	DATE
TRAFFIC ENGINEERING	DATE
PARKS & RECREATION DEPARTMENT	DATE
A.B.C.W.U.A.	DATE
A.M.A.F.C.A.	DATE
CITY ENGINEER	DATE
DRB CHAIRPERSON, PLANNING DEPARTMENT	DATE

SURVEYOR'S CERTIFICATION

I, Gary E. Gritsko, a duly qualified Registered Professional Land Surveyor under the laws of the State of New Mexico, do hereby certify that this plat and description were prepared by me or under my supervision, shows all easements as shown on the plat of record or made known to me by the owners and/or proprietors of the subdivision shown hereon, utility companies and other parties expressing an interest and meets the minimum requirements for monumentation and surveys of the Albuquerque Subdivision Ordinance, and further meets the Minimum Standards for Land Surveying in the State of New Mexico and is true and correct to the best of my knowledge and belief.

[Signature]
 Gary E. Gritsko
 New Mexico Professional Surveyor, 8686

Aug. 9, 2010
 Date



ALPHA PROFESSIONAL SURVEYING, INC.
 P.O. BOX 46316, RIO RANCHO, NEW MEXICO 87174
 (505) 892-1076 FAX (505) 891-0471
 DRAWN BY: CS FILE NO: 10-083

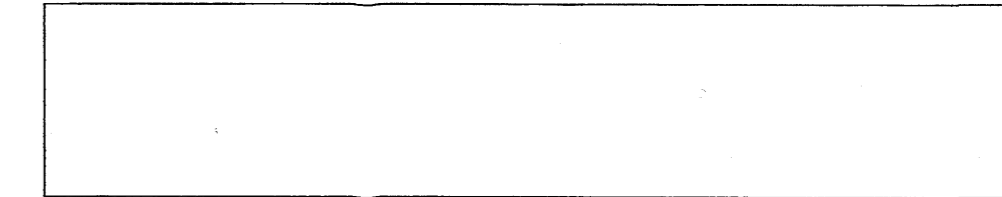

PLAT OF
 LOTS 4-A & 5-A, BLOCK 17
 JUAN TABO HILLS, UNIT 1
 in Section 34, T10N, R4E, NMPM
 City of Albuquerque
 Bernalillo County, New Mexico
 July 2010

NOTE: SOLAR RESTRICTIONS

No property within the area of requested final plat shall at any time be subject to a deed restriction, covenant or binding agreement prohibiting solar collectors from being installed on buildings or erected on the lots or parcels within the area of proposed plat. The foregoing requirement shall be a condition to approval of this plat for subdivision.

EASEMENT NOTES:

A. 10' Public Utility Easements granted by the plat of Juan Tabo Hills, Unit 1, recorded on December 22, 2005 in Bk. 2005C, Pg. 406.

UTILITY APPROVALS

PUBLIC UTILITY EASEMENTS SHOWN ON THIS PLAT ARE GRANTED FOR THE COMMON AND JOINT USE OF:

A. PUBLIC SERVICE COMPANY OF NEW MEXICO (PNM) A NEW MEXICO CORPORATION, (PNM ELECTRIC) FOR INSTALLATION, MAINTENANCE, AND SERVICE OF OVERHEAD AND UNDERGROUND ELECTRICAL LINES, TRANSFORMERS, OTHER EQUIPMENT AND RELATED FACILITIES REASONABLY NECESSARY TO PROVIDE ELECTRICAL SERVICES.

B. NEW MEXICO GAS COMPANY FOR INSTALLATION, MAINTENANCE, AND SERVICE OF NATURAL GAS LINES, VALVES AND OTHER EQUIPMENT AND FACILITIES REASONABLY NECESSARY TO PROVIDE NATURAL GAS SERVICES.

C. QWEST COMMUNICATIONS FOR THE INSTALLATION, MAINTENANCE AND SERVICE OF SUCH LINES, CABLE, AND OTHER RELATED EQUIPMENT AND FACILITIES REASONABLY NECESSARY TO PROVIDE COMMUNICATION SERVICES.

D. COMCAST CABLE FOR THE INSTALLATION, MAINTENANCE AND SERVICE OF SUCH LINES, CABLE, AND OTHER RELATED EQUIPMENT AND FACILITIES REASONABLY NECESSARY TO PROVIDE CABLE TV SERVICES.

INCLUDED, IS THE RIGHT TO BUILD, REBUILD, CONSTRUCT, RECONSTRUCT, LOCATE, RELOCATE, CHANGE, REMOVE, MODIFY, RENEW, OPERATE, AND MAINTAIN FACILITIES FOR THE PURPOSES DESCRIBED ABOVE, TOGETHER WITH FREE ACCESS TO, FROM AND OVER SAID EASEMENTS, WITH THE RIGHT AND PRIVILEGE OF GOING UPON, OVER AND ACROSS ADJOINING LANDS OF GRANTOR FOR THE PURPOSE SET FORTH HEREIN AND WITH THE RIGHT TO UTILIZE THE RIGHT OF WAY AND EASMENT TO EXTEND SERVICES TO CUSTOMERS OF GRANTEE, INCLUDING SUFFICIENT WORKING AREA SPACE FOR ELECTRIC TRANSFORMERS, WITH THE RIGHT AND PRIVILEGE TO TRIM AND REMOVE TREES, SHRUBS OR BUSHES WHICH INTERFERE WITH THE PURPOSES SET FORTH HEREIN. NO BUILDING, SIGN, POOL (ABOVEGROUND OR SUBSURFACE), HOT TUB, CONCRETE OR WOOD POOL DECKING, OR OTHER STRUCTURES SHALL BE ERRECTED OR CONSTRUCTED ON SAID EASEMENTS NOR SHALL ANY WELL BE DRILLED OR OPERATED THEREON. PROPERTY OWNERS SHALL BE SOLELY RESPONSIBLE FOR CORRECTING ANY VIOLATIONS OF NATIONAL ELECTRICAL SAFETY CODE BY CONSTRUCTION OF POOL, DECKING, OR ANY STRUCTURES ADJACENT TO OR NEAR EASEMENTS SHOWN ON THIS PLAT.

EASEMENTS FOR ELECTRIC TRANSFORMERS/SWITCHGEARS, AS INSTALLED, SHALL EXTEND TEN (10) FEET IN FRONT OF TRANSFORMER/SWITCHGEAR DOORS AND FIVE (5) FEET ON EACH SIDE.

DISCLAIMER:
 IN APPROVING THIS PLAT, PUBLIC SERVICE COMPANY OF NEW MEXICO (PNM) AND NEW MEXICO GAS COMPANY (NMGC) DID NOT CONDUCT A TITLE SEARCH OF THE PROPERTIES SHOWN HEREON. CONSEQUENTLY, PNM AND NMGC DO NOT WAIVE OR RELEASE ANY EASEMENT OR EASEMENT RIGHTS WHICH MAY HAVE BEEN GRANTED BY PRIOR PLAT, REPLAT OR OTHER DOCUMENT AND WHICH ARE NOT SHOWN ON THIS PLAT.

EASEMENTS FOR ELECTRIC TRANSFORMERS/SWITCHGEARS, AS INSTALLED, SHALL EXTEND TEN FEET (10) IN FRONT OF TRANSFORMER/SWITCHGEAR DOORS AND FIVE FEET (5) ON EACH SIDE.

 PUBLIC SERVICE CO. OF NEW MEXICO DATE

 QWEST COMMUNICATIONS DATE

 NEW MEXICO GAS COMPANY DATE

 COMCAST CABLE DATE

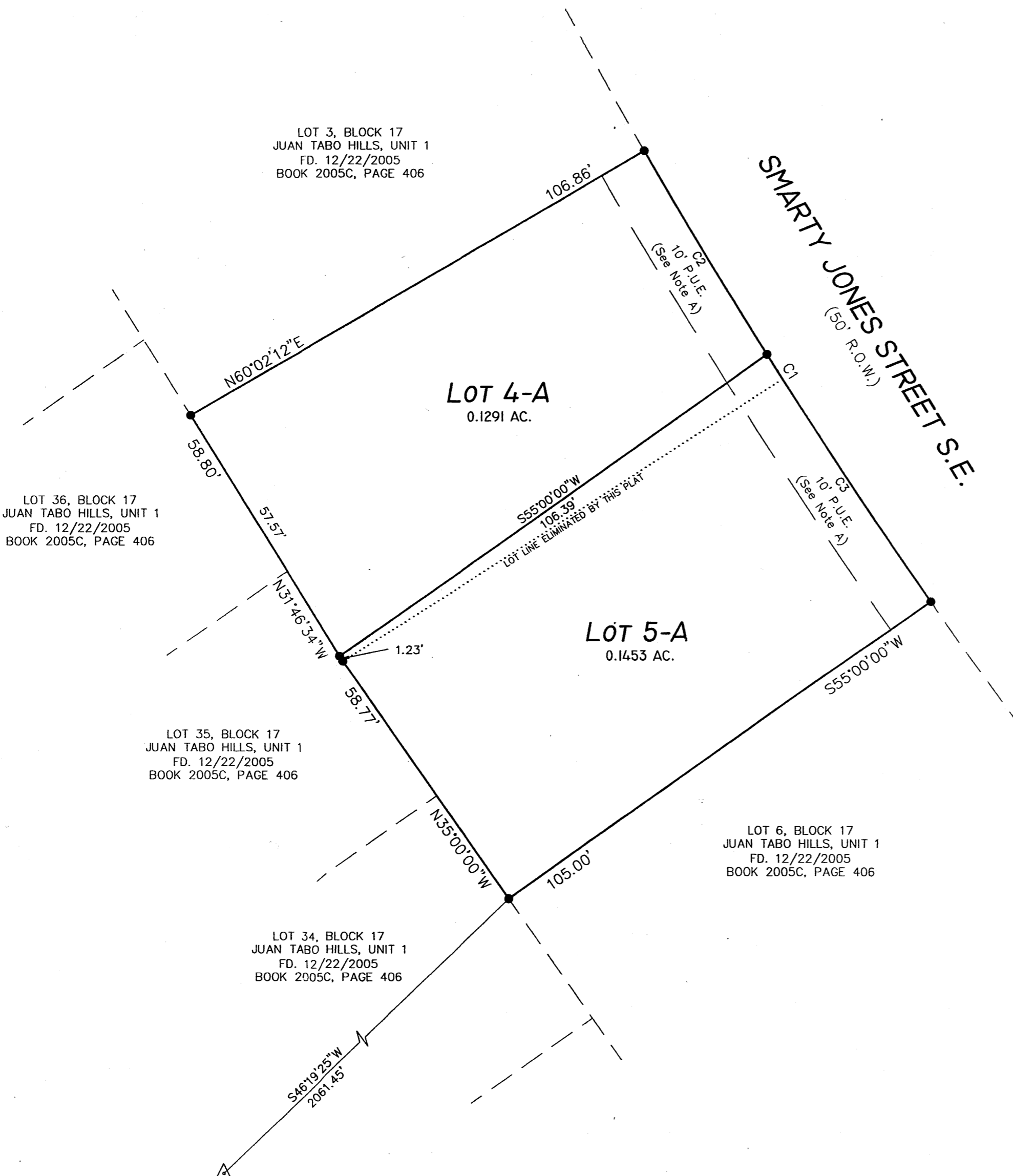

ACRS STATION "7_M21"
 NM STATE PLANE COORDINATES
 N=1471683.328, E=1559637.958
 CENTRAL ZONE (NAD 83)
 G-G FACTOR: 0.999648202
 MAPPING ANGLE: -0°09'17.90"

MONUMENT LEGEND

- △ - FOUND CONTROL STATION AS NOTED
- - FOUND MONUMENT AS NOTED
- - SET 1/2" REBAR W/YELLOW PLASTIC CAP STAMPED "GRITSKO LS8686" UNLESS OTHERWISE NOTED

CURVE TABLE					
CURVE	LENGTH	RADIUS	CHORD BEARING	CHORD	DELTA
C1	108.23	1231.16	S32°28'54"E	108.20	05°02'13"
C2	48.21	1231.16	S31°05'06"E	48.21	02°14'37"
C3	60.02	1231.16	S33°36'13"E	60.02	02°47'36"

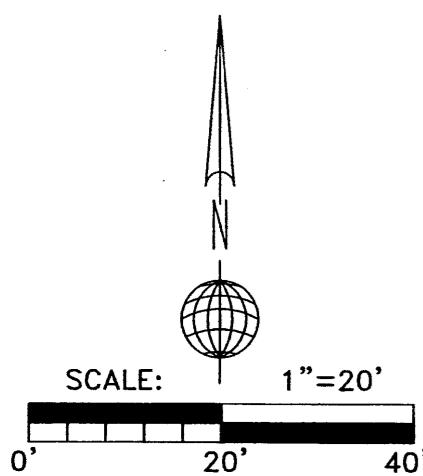

ALPHA PROFESSIONAL SURVEYING, INC.
 P.O. BOX 46316, RIO RANCHO, NEW MEXICO 87174
 PHONE (505) 892-1076 FAX (505) 891-0471
 DRAWN BY: CS FILE NO: 10-083