



DEVELOPMENT REVIEW BOARD SUPPLEMENTAL SUBMITTAL

PROJECT NO. 1008585
Application No. 18DRB-70113

TO:

- Kym Dicome, DRB Chair, Planning Department**
- James Hughes, P.E., Hydrology**
- Racquel Michel, P.E., Transportation Development**
- Kris Cadena, P.E., Albuquerque/ Bernalillo Co. WUA**
- Ben McIntosh, Code Enforcement**
- Jason Coffey, Parks/Municipal Development**

NOTE: PDF Required
***(Please attach this sheet with each collated set per board member)**

NEXT HEARING DATE: June 6, 2018

NOTE: REQUESTS FOR DEFERRAL OF CASES WILL BE DISCUSSED BY THE BOARD AND THE APPLICANT AND/OR AGENT AT THE BEGINNING OF THE AGENDA. BOTH PARTIES MUST AGREE UPON THE DATE OF DEFERRAL. IF THE APPLICANT/AGENT IS NOT PRESENT, THE ADMINISTRATIVE ASSISTANT MUST RECEIVE A LETTER, PRIOR TO THE HEARING DATE, REQUESTING A SPECIFIC DEFERRAL DATE. THE BOARD WILL DISCUSS AND MAKE A DECISION AT THE HEARING. THE APPLICANT/AGENT WILL THEN BE INFORMED OF THE DEFERRAL DATE AND REASON. IF THE APPLICANT IS NOT PRESENT WHEN THEIR REQUEST IS CALLED, THEN THE REQUEST MAY BE INDEFINITELY DEFERRED ON A NO SHOW.

SUBMITTAL DESCRIPTION: Updated Plan Set with Updated Infrastructure List

CONTACT NAME: Vince Carrica

TELEPHONE: 505-858-3100 **EMAIL:** vcarrica@tierrawestllc.com

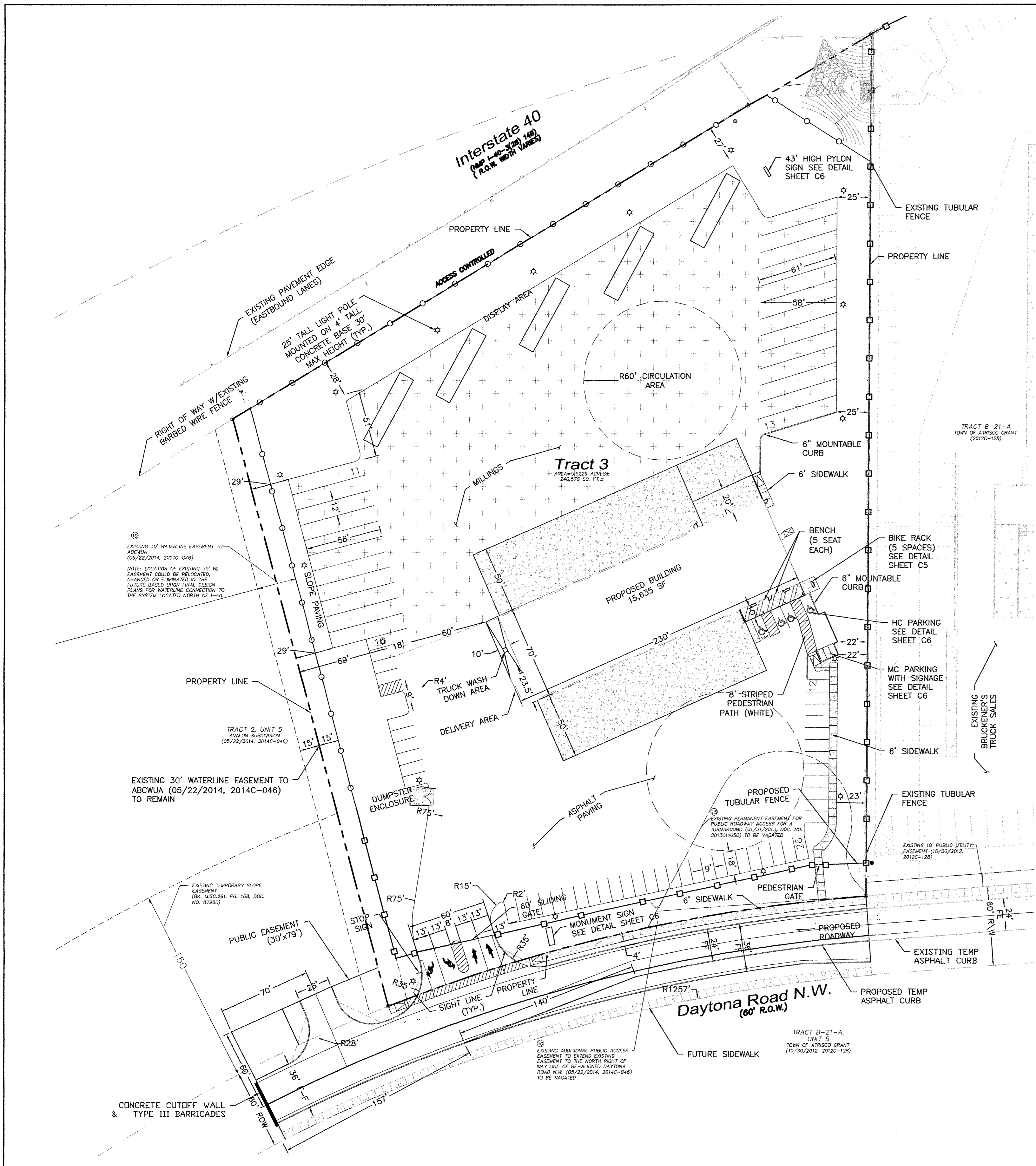

- LEGEND**
- CURB & GUTTER
 - - - PROPERTY LINE
 - - - EASEMENT
 - - - CENTERLINE
 - - - RIGHT-OF-WAY
 - ▭ BUILDING
 - ▨ SIDEWALK/CONCRETE APRON
 - ▩ PAVEMENT
 - ▧ MILLINGS
 - ▤ SCREEN WALL
 - ▥ RETAINING WALL
 - ☼ STREET LIGHTS
 - - - LANE
 - - - STRIPING
 - - - EXISTING CURB & GUTTER
 - - - EXISTING BOUNDARY LINE
 - ▨ EXISTING SIDEWALK
 - - - EXISTING LANE
 - - - EXISTING STRIPING
 - 6" CHAIN LINK FENCE (GALVANIZED) W/INTRUDER BARRIER ON TOP
 - 6" TUBULAR STEEL FENCE (BLACK)

SITE DATA

PROPOSED USAGE: UTILITY TRAILER SALES/SERVICING
 LOT AREA: 240,578 SF (5.52 ACRE)

BUILDING AREA:
 TOTAL 15,635 SF

PARKING REQUIRED: 75 SPACES (15,000 SF/1 SPACE PER 200 SF)
 PARKING REQUIRED: 3 SPACES (635 SF/1 SPACE PER 250 SF)
 MINUS: 9 SPACES (SERVICE BAYS)
 TOTAL PARKING REQUIRED: 69 SPACES

*PARKING PROVIDED: 77 SPACES

HC PARKING REQUIRED: 4 SPACES
 HC PARKING PROVIDED: 4 SPACES
 2 SPACE VAN ACCESSIBLE

MC PARKING REQUIRED: 3 SPACES
 MC PARKING PROVIDED: 3 SPACES

BICYCLE PARKING REQUIRED: 4 SPACES (1 SPACE PER 20 PARKING SPACES)
 BICYCLE PARKING PROVIDED: 5 SPACES

LANDSCAPE AREA REQUIRED: 33,741 SF
 LANDSCAPE AREA PROVIDED: 74,851 SF

ALL IMPROVEMENTS LOCATED IN THE RIGHT OF WAY MUST BE INCLUDED ON A PUBLIC WORK ORDER.

LANDSCAPING, FENCING AND SIGNING WILL NOT INTERFERE WITH CLEAR SIGHT TRIANGLES @ENTRANCE OFF DAYTONA. SIGNS, WALLS, TREES, AND SHRUBBERY BETWEEN 3 AND 8 FEET TALL (AS MEASURED FROM THE GUTTER PAN) WILL NOT BE ACCEPTABLE IN THE CLEAR SIGHT TRIANGLE.

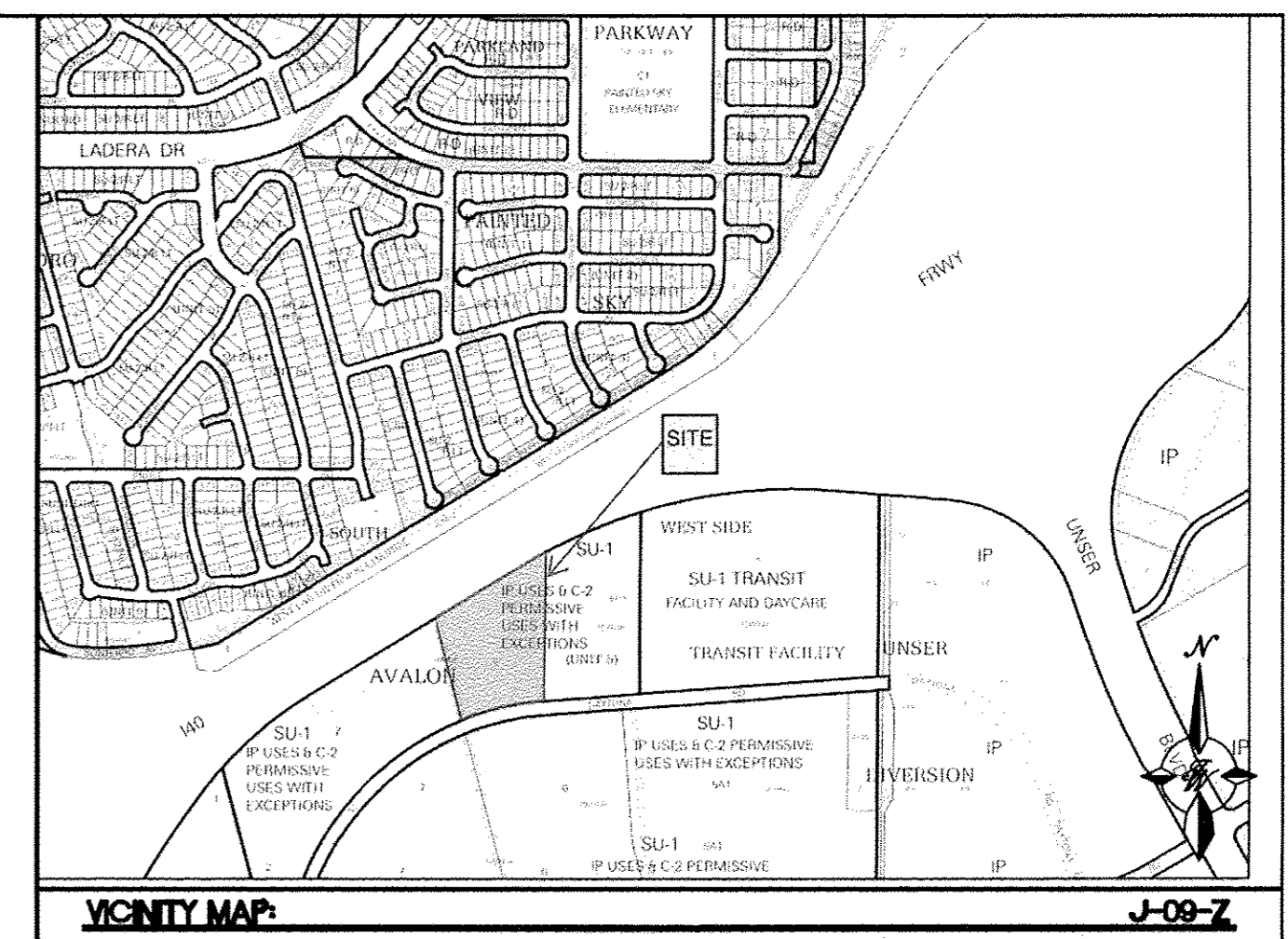

LEGAL DESCRIPTION:
 TRACT NUMBERED 3, OF PLAT OF TRACTS 1 THROUGH 12, AVALON SUBDIVISION UNIT 5, ALBUQUERQUE, BERNALILLO COUNTY, NEW MEXICO, AS THE SAME IS SHOWN AND DESIGNATED ON THE PLAT OF SAID SUBDIVISION, FILED IN THE OFFICE OF THE COUNTY CLERK OF BERNALILLO COUNTY, NEW MEXICO ON MAY 22, 2014, IN PLAT BOOK 2014C, FOLIO 46, AS DOCUMENT NO. 2014040949.

ADDRESS: 8201 DAYTONA RD NW
 ALBUQUERQUE, NM 87121

PAVING TYPE: ASPHALT PAVEMENT SOUTH PARKING FIELD
 ASPHALT MILLINGS NORTH PARKING FIELD
 ZONING: SU-1, IP USES & C2 PERMISSIVE USES W/EXCEPTIONS

*TRUCK PARKING IS ALLOWED TO BE COUNTED IN TOTAL NUMBER OF SPACES PROVIDED

PROJECT NUMBER: _____
APPLICATION NUMBER: _____

This plan is consistent with the specific Site Development Plan approved by the Environmental Planning Commission (EPC), dated _____ and the Findings and Conditions in the Official Notification of Decision are satisfied.

Is an Infrastructure List required? () Yes () No If Yes, then a set of approved DRP plans with a work order is required for any construction within Public Right-of-Way or for construction of public improvements.

DRB SITE DEVELOPMENT PLAN SIGNOFF APPROVAL:

Traffic Engineer, Transportation Division	Date
Water Utility Development	Date
Parks & Recreation Department	Date
City Engineer	Date
* Environmental Health Department (conditional)	Date
Solid Waste Management	Date
DRB Chairperson, Planning Department	Date

* Environmental Health, if necessary

- INDEX TO DRAWINGS**
- C1. SITE PLAN FOR BUILDING PERMIT
 - C2. CONCEPTUAL GRADING AND DRAINAGE PLAN
 - C3. CONCEPTUAL MASTER UTILITY PLAN
 - C4. BUILDING ELEVATIONS
 - C5. DETAIL SHEET 01
 - C6. DETAIL SHEET 02
 - L1. LANDSCAPING PLAN

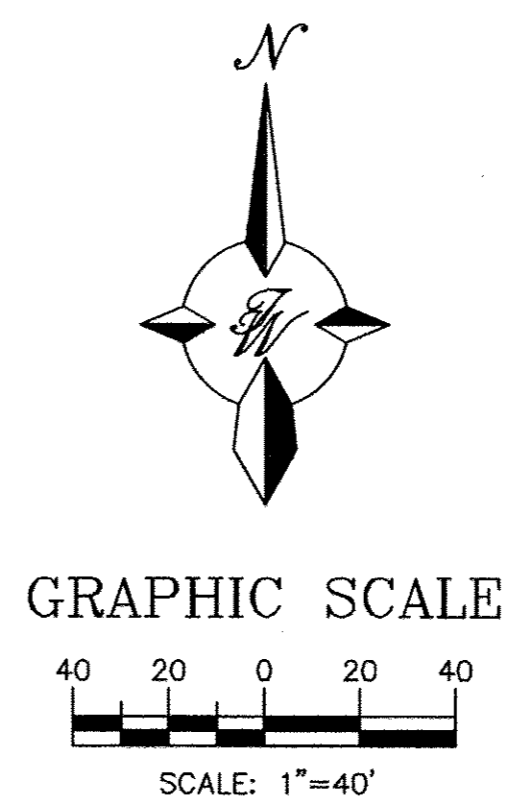

	UTILITY TRAILER SALES PROJECT LOCATION	DRAWN BY LA
	SITE PLAN FOR BUILDING PERMIT	DATE 05/23/2018
		SHEET # C1
5571 MIDWAY PARK PLACE NE ALBUQUERQUE, NM 87109 (505) 858-3100 www.tierrawestllc.com		JOB # 2017041
RONALD R. BOHANNAN P.E. #7868		

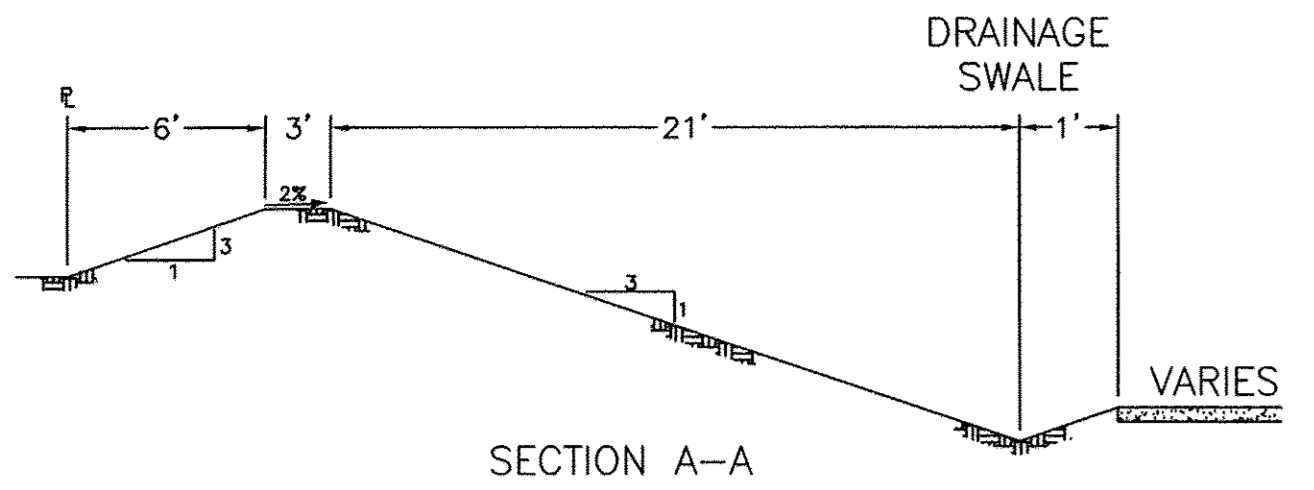

A.G.R.S. MONUMENT "REWARD"
STANDARD A.G.R.S. BRASS TABLET
(FOUND IN PLACE)
NEW MEXICO STATE PLANE COORDINATES
(CENTRAL ZONE-N.M.D. 1983)
N=1,487,384.063
E=1,491,180.819
PUBLISHED ELEVATION=5216.828 (MAYD 1988)
GROUND TO GRID FACTOR=-0.999970005
DELTA ALPHA ANGLE=-01712.26"

SECTION A-A

- LEGEND**
- CURB & GUTTER
 - BOUNDARY LINE
 - - - EASEMENT
 - CENTERLINE
 - RIGHT-OF-WAY
 - BUILDING
 - SIDEWALK
 - SCREEN WALL
 - RETAINING WALL
 - 5010 — CONTOUR MAJOR
 - 5011 — CONTOUR MINOR
 - x 5048.25 SPOT ELEVATION
 - FLOW ARROW
 - - - EXISTING CURB & GUTTER
 - - - EXISTING BOUNDARY LINE
 - - - EXISTING CONTOUR MAJOR
 - - - EXISTING CONTOUR MINOR
 - - - EXISTING SPOT ELEVATION

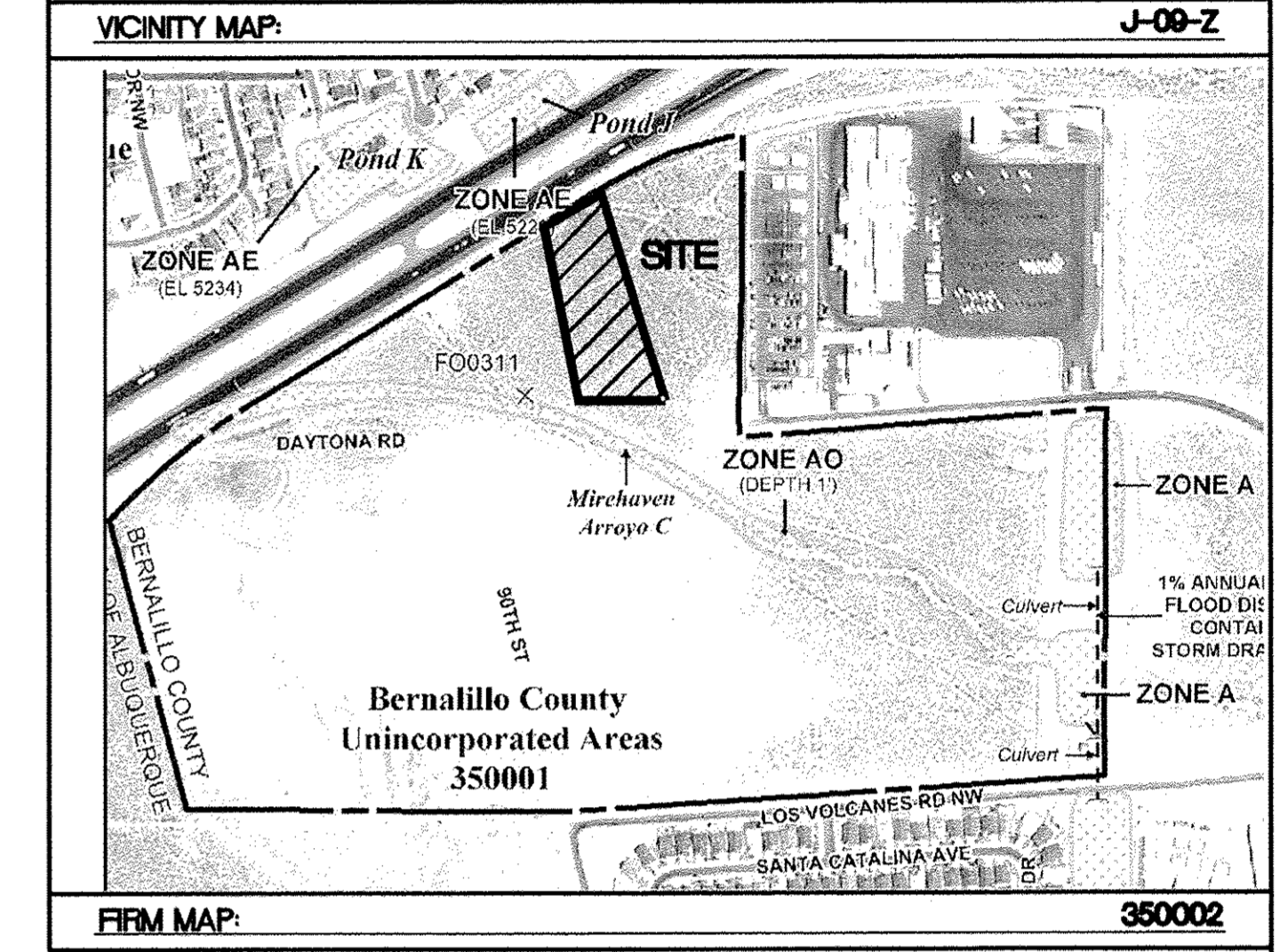
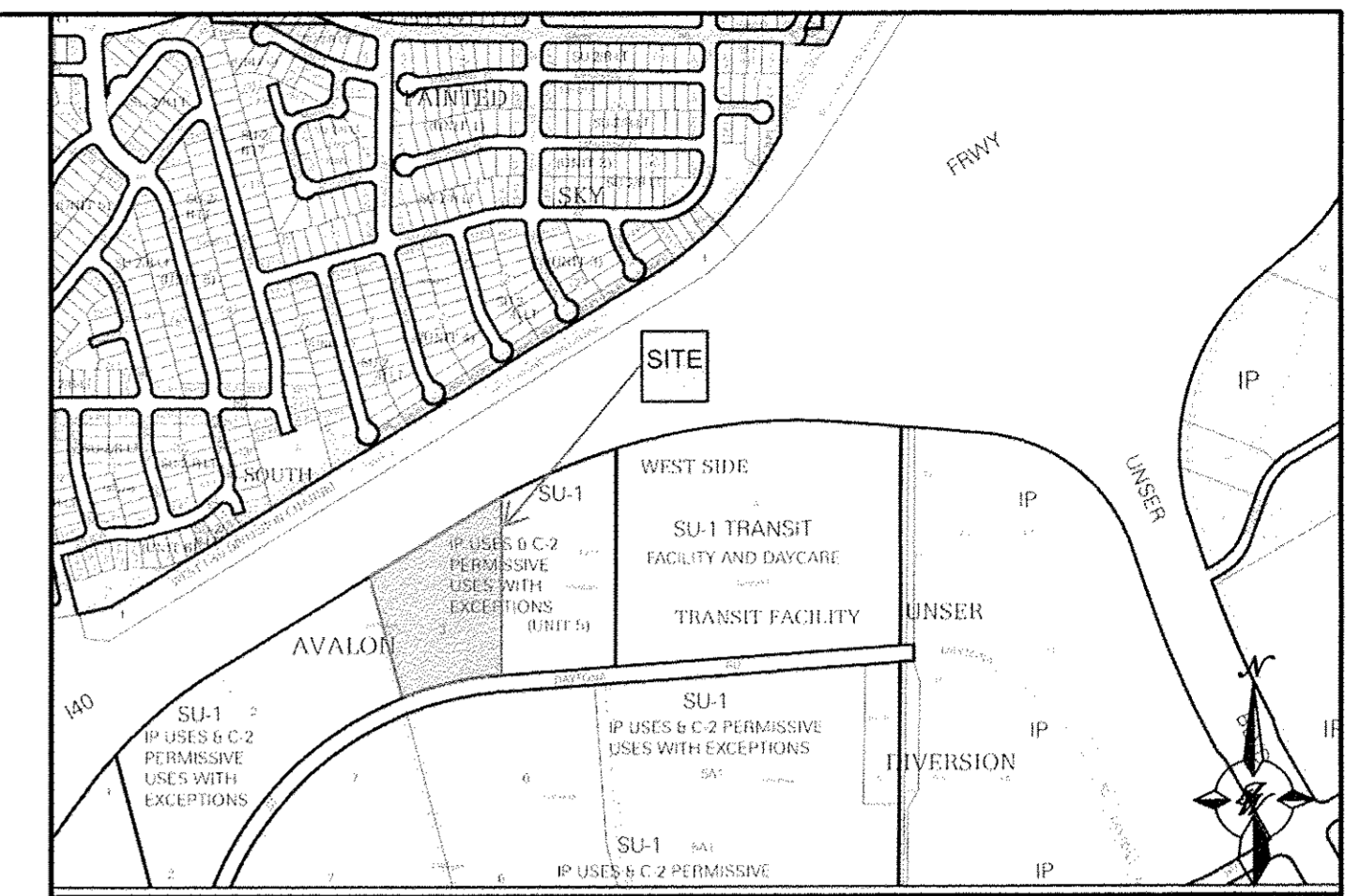

SITE BENCHMARK
SET CP-CHISLED "1"
N=1,488,571.239
E=1,494,618.639
ELEV=5233.259

EXISTING 30" CMP
W/CONCRETE
BLANKET

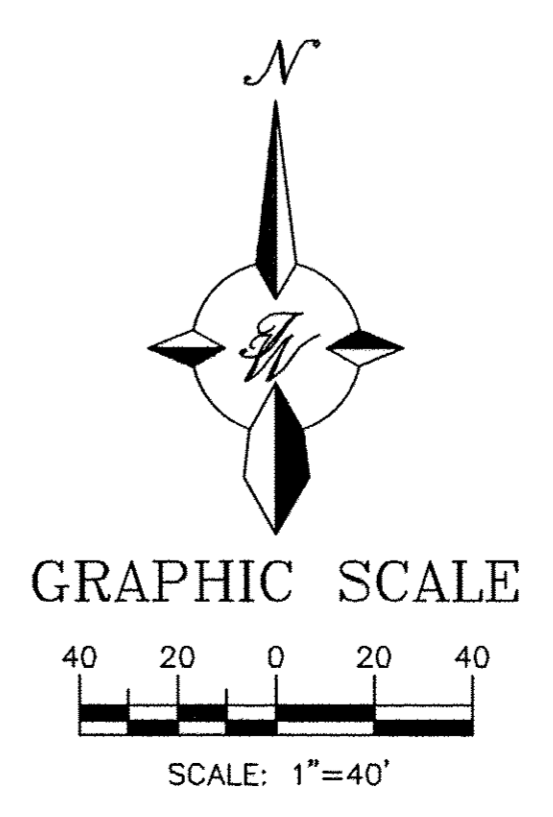
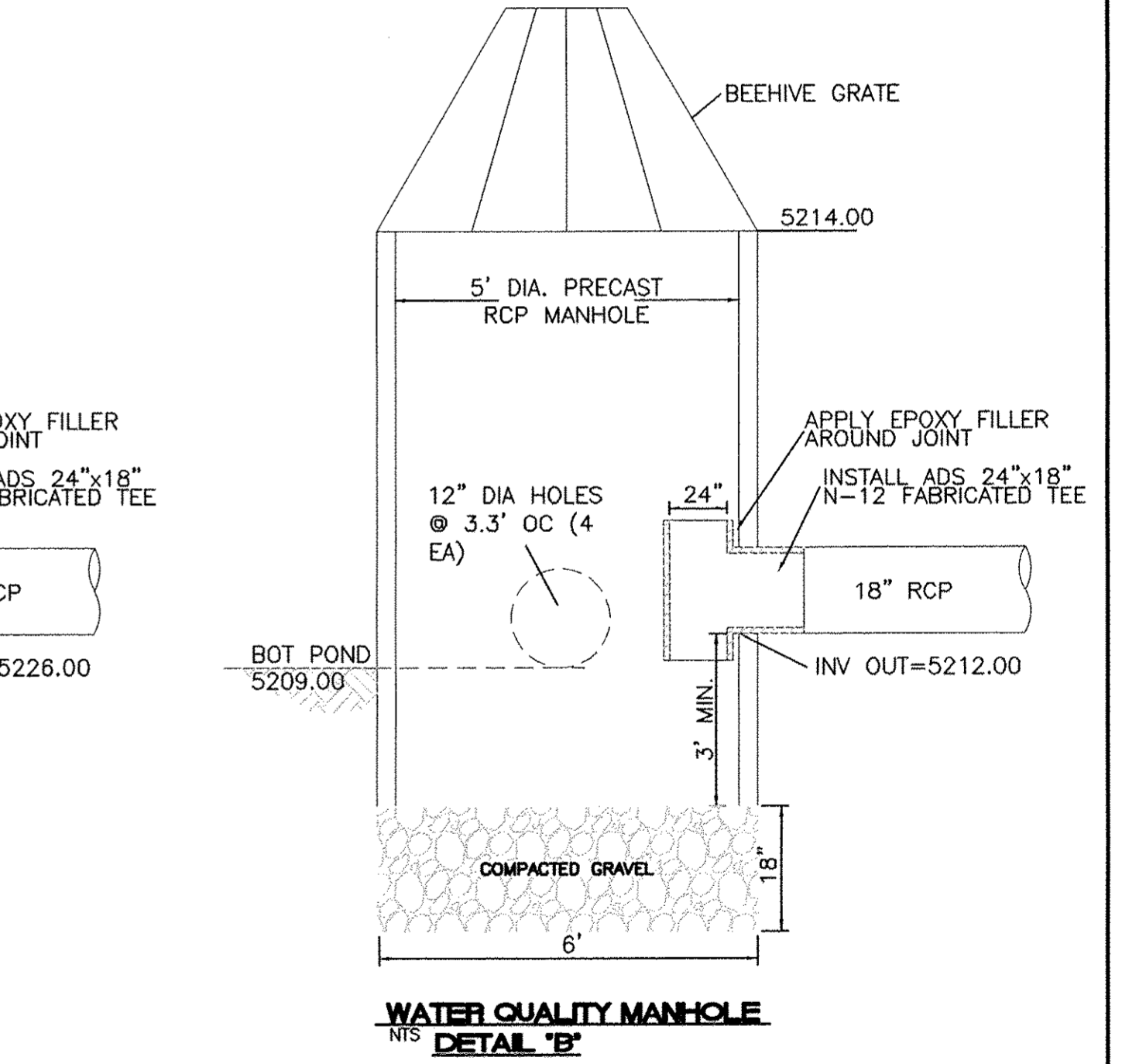
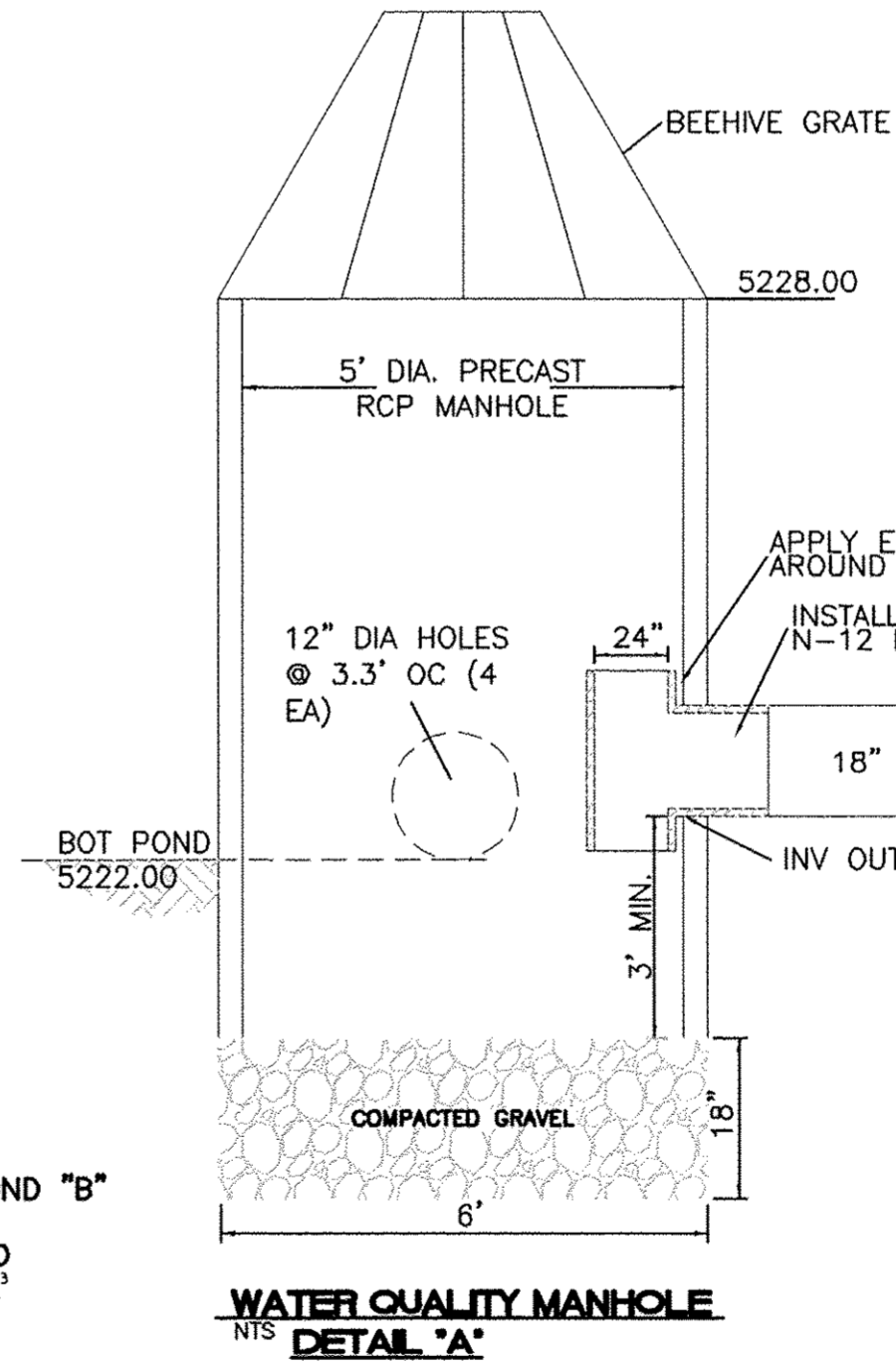
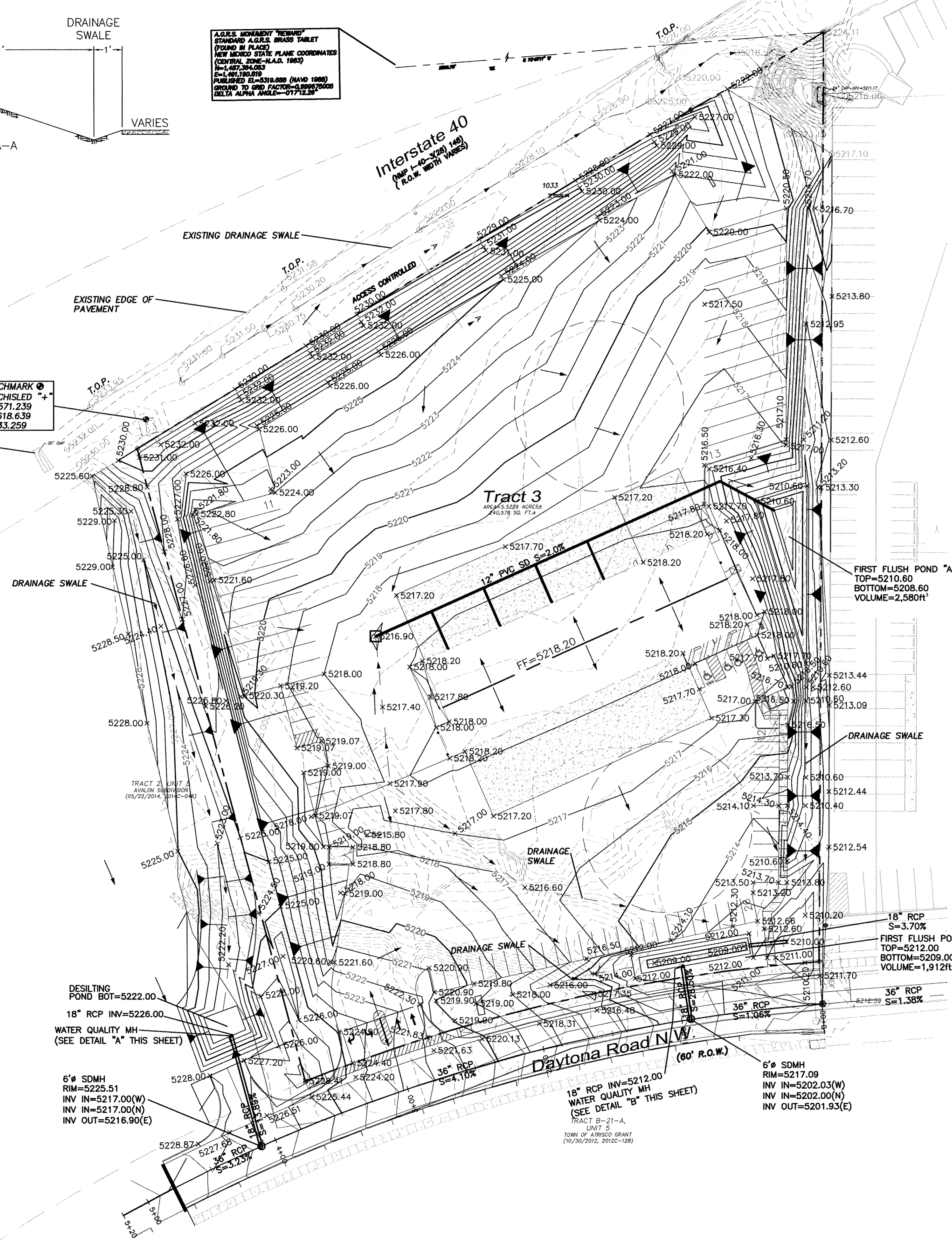

ENGINEER'S SEAL	UTILITY TRAILER SALES ALBUQUERQUE NM	DRAWN BY LA
	CONCEPTUAL GRADING AND DRAINAGE PLAN	DATE 05/23/2018
	TERRA WEST, LLC 5571 MIDWAY PARK PLACE NE ALBUQUERQUE, NM 87109 (505) 858-3100 www.tierwestllc.com	2017041-GRADING 2
VINCENT P. CARRICA P.E. #16212		JOB # 2017041

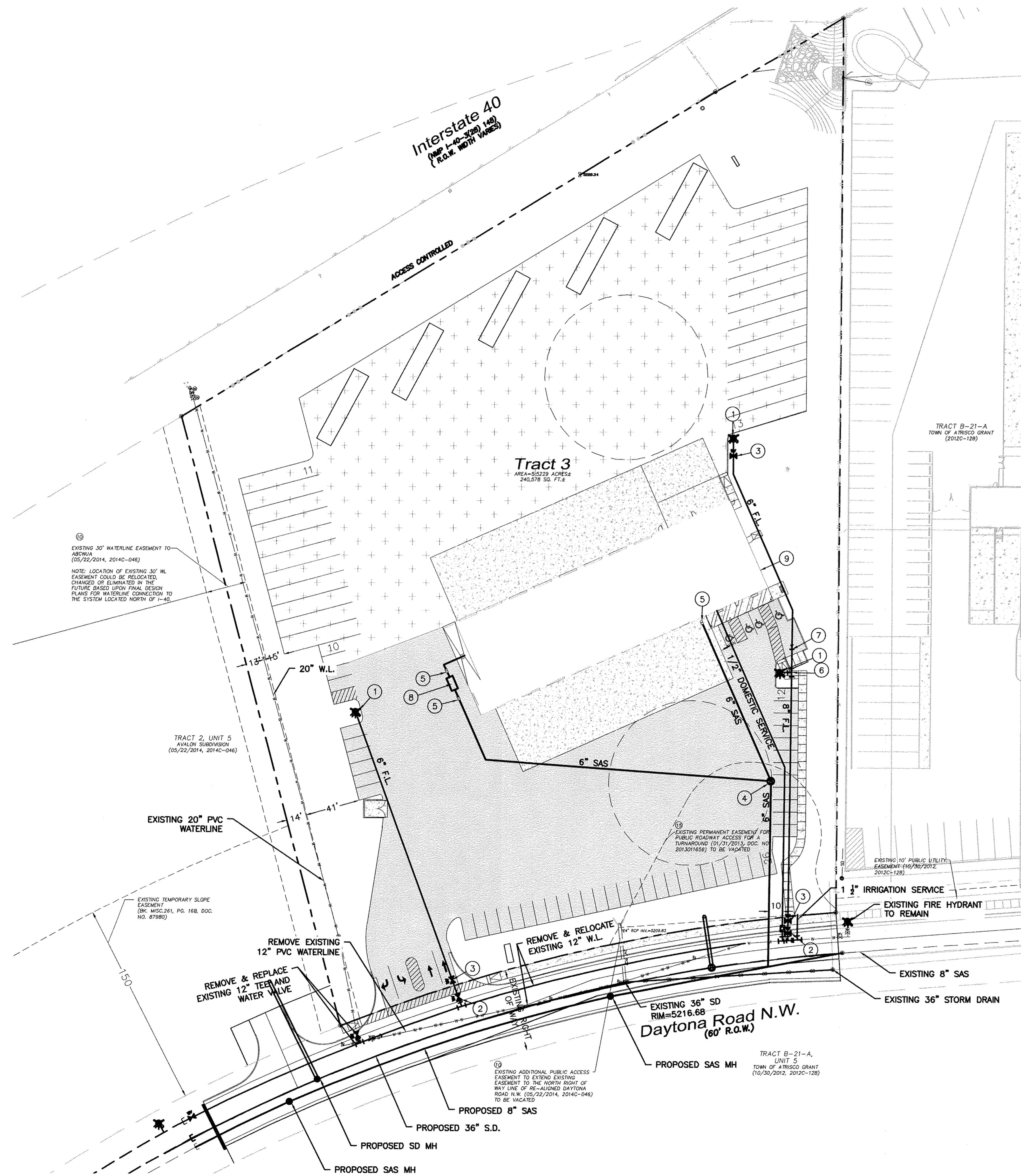

KEYED NOTE:

- ① FIRE HYDRANT (PRIVATE) TO BE PAINTED SAFETY ORANGE
- ② GATE VALVE (PUBLIC)
- ③ GATE VALVE (PRIVATE)
- ④ 4' DIAMETER MANHOLE
- ⑤ DOUBLE CLEANOUT
- ⑥ 8"x8"x6" TEE
- ⑦ 8" TO 6" REDUCER
- ⑧ OIL/WATER SEPARATOR
- ⑨ GAS METER

LEGEND

- CURB & GUTTER
- - - BOUNDARY LINE
- - - EASEMENT
- - - CENTERLINE
- - - RIGHT-OF-WAY
- ▭ BUILDING
- ▭ SIDEWALK
- ▭ SCREEN WALL
- ▭ RETAINING WALL
- - - EXISTING CURB & GUTTER
- - - EXISTING BOUNDARY LINE
- 36" SD — STORM SEWER LINE
- 8" SAS — SANITARY SEWER LINE
- 8" WL — WATERLINE
- SINGLE CLEAN OUT
- ⊕ DOUBLE CLEAN OUT
- ⊕ EXISTING SD MANHOLE
- ⊕ EXISTING INLET
- ⊕ EXISTING SAS MANHOLE
- ⊕ EXISTING FIRE HYDRANT
- ⊕ EXISTING WATER VALVE
- ⊕ EXISTING WATER METER
- ⊕ EXISTING POWER POLE
- ⊕ EXISTING GAS VALVE
- - - EXISTING OVERHEAD UTILITIES
- - - EX. LOGE - - - EXISTING UNDERGROUND UTILITIES
- - - EX. 2" GAS - - - EXISTING GAS
- - - EX. 8" SAS - - - EXISTING SANITARY SEWER LINE
- - - EX. 10" WL - - - EXISTING WATER LINE
- - - EX. 18" RCP - - - EXISTING STORM SEWER LINE

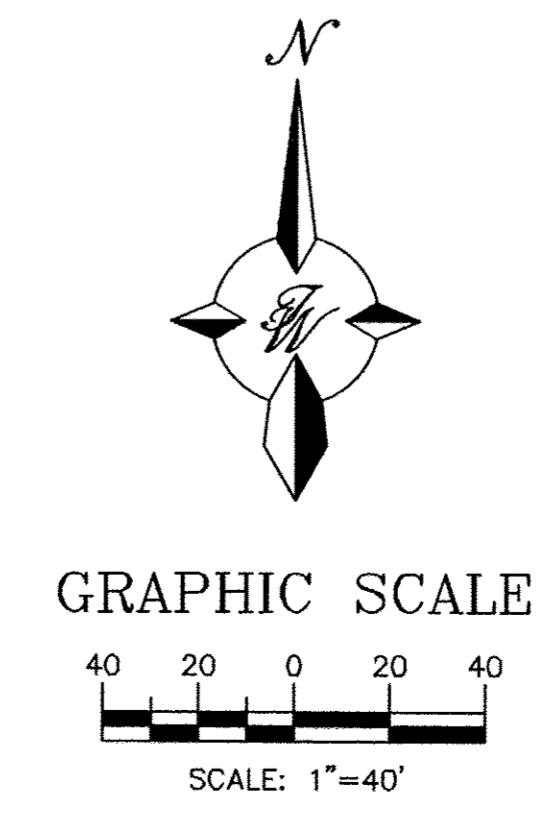

ENGINEER'S SEAL 	UTILITY TRAILER SALES PROJECT LOCATION	DRAWN BY LA
	CONCEPTUAL UTILITY PLAN	DATE 05/23/2018
5571 MIDWAY PARK PLACE NE ALBUQUERQUE, NM 87109 (505) 858-3100 www.tierrowestllc.com		2017041_MUE 2
SHEET # C3		JOB # 2017041

GENERAL NOTES

- BUILDING MOUNTED SIGN AREA NOT TO EXCEED 12.5% OF TOTAL BUILDING FACADE.

TOTAL BUILDING FACADE AREA	4,792 SF
12.5% ALLOWABLE SIGN AREA	599 SF
TOTAL PROPOSED SIGN AREA	261 SF

ARIA

STUDIO CONSULTANTS, INC
 PO BOX 1515
 CEDAR CREST NM, 87008
 DANIEL@ARIASCINC.COM
 (505) 506-2314

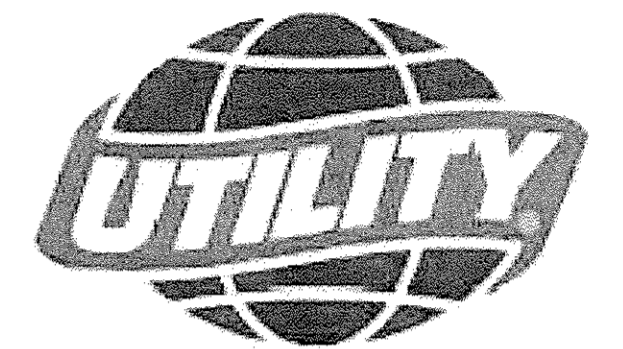

**UTILITY TRAILER
 NEW MEXICO**
 8201 DAYTONA RD NW
 ALBUQUERQUE, NM 87121

Architect/Engineer

MARK	DATE	DESCRIPTION
REVISIONS		
ISSUE		
PROJECT NO	1721	
CAD DWG FILE	1721-A101	
DRAWN BY	DGW	
CHECKED BY	DGP	
DATE	1/18/18	

BUILDING ELEVATIONS

A201

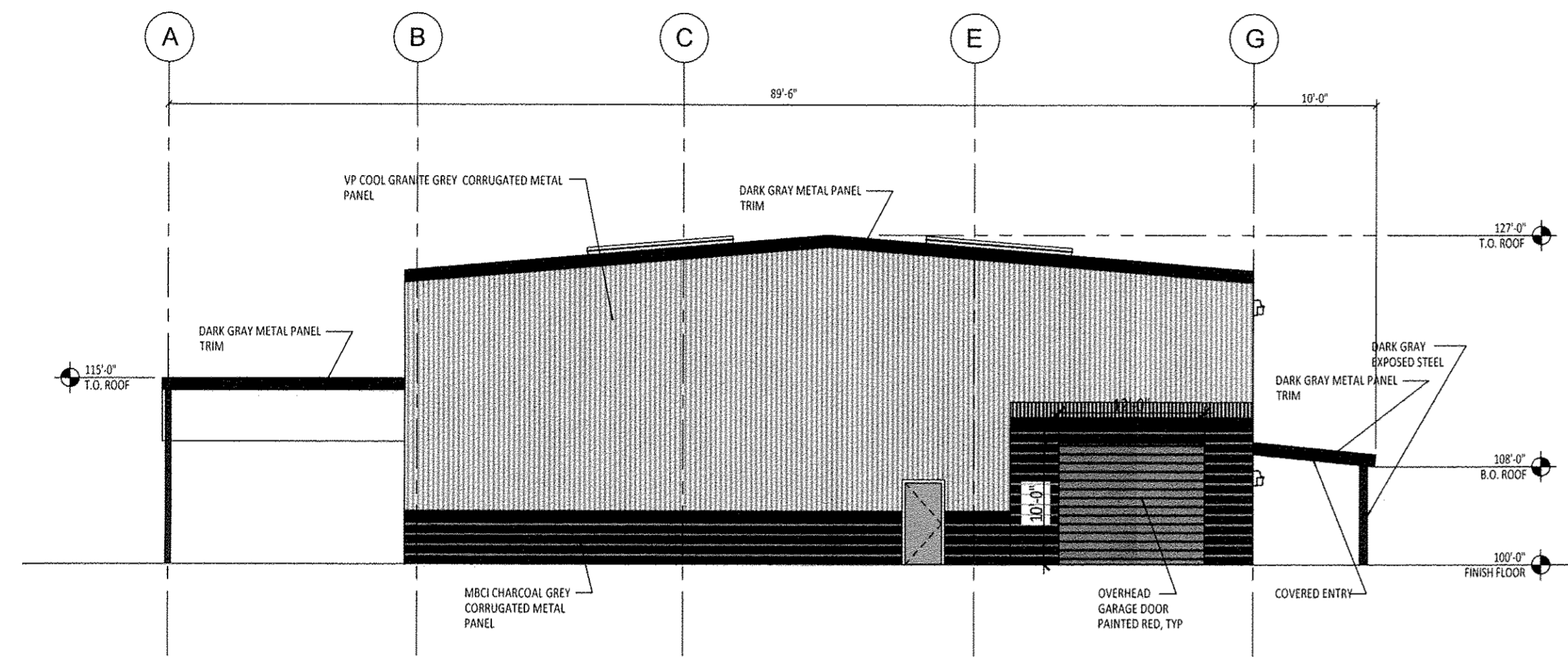

C1 WEST ELEVATION
 1/8" = 1'-0"

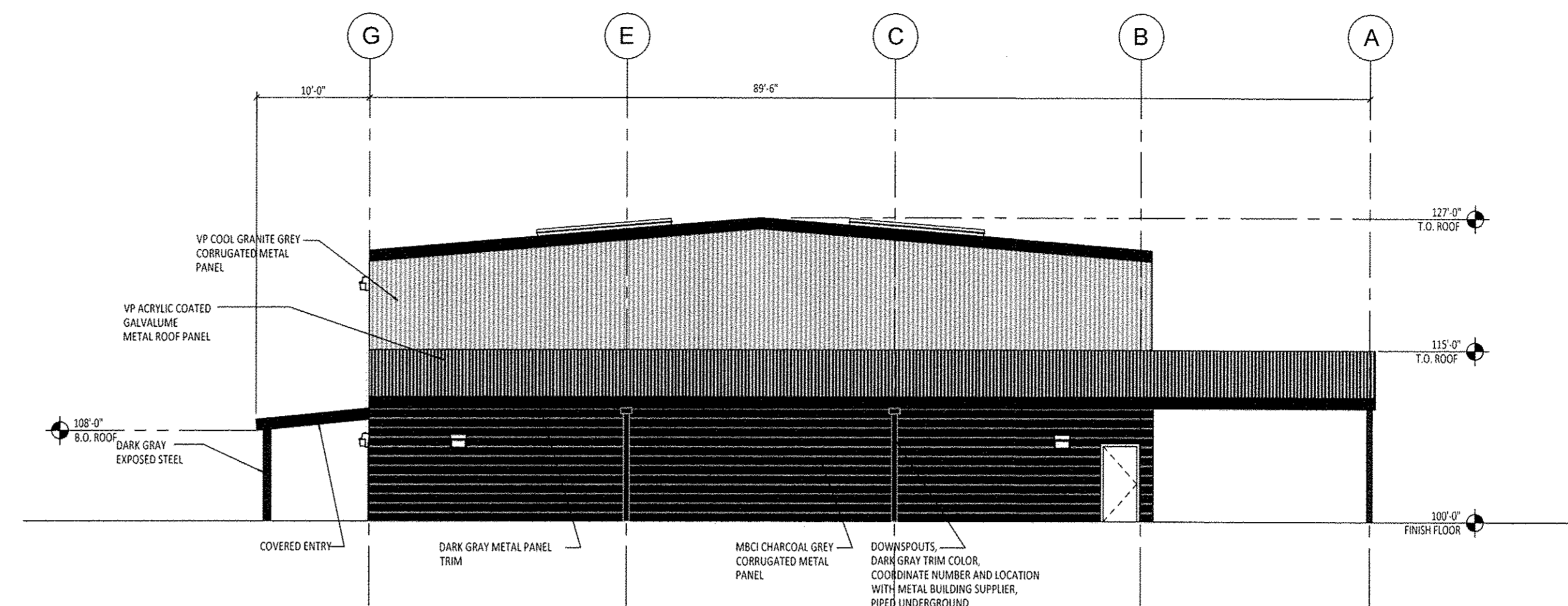

C2 EAST ELEVATION
 1/8" = 1'-0"

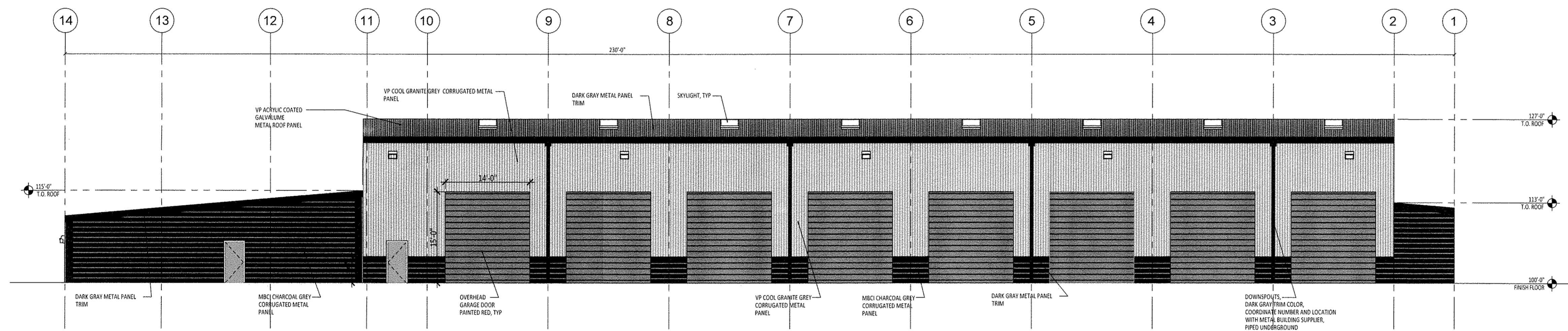

B1 NORTH ELEVATION
 1/8" = 1'-0"

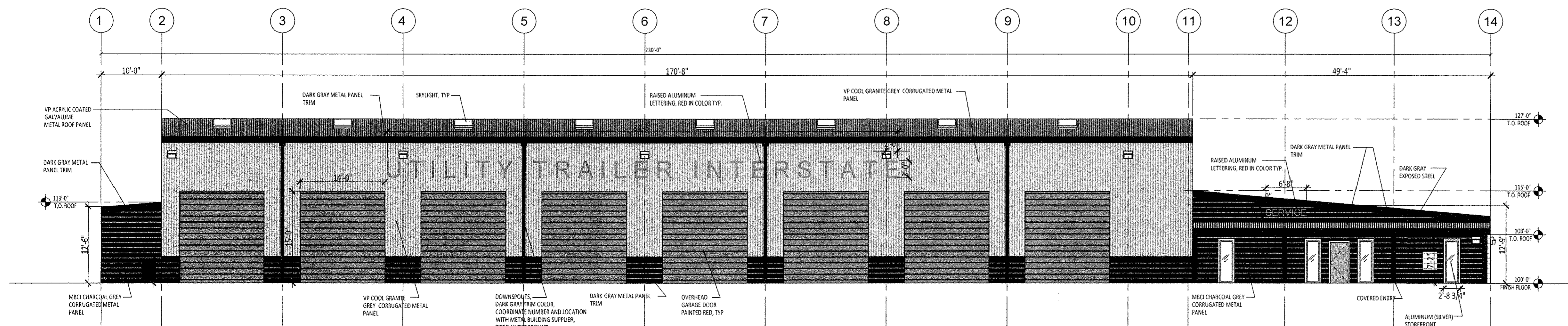

A1 SOUTH ELEVATION
 1/8" = 1'-0"

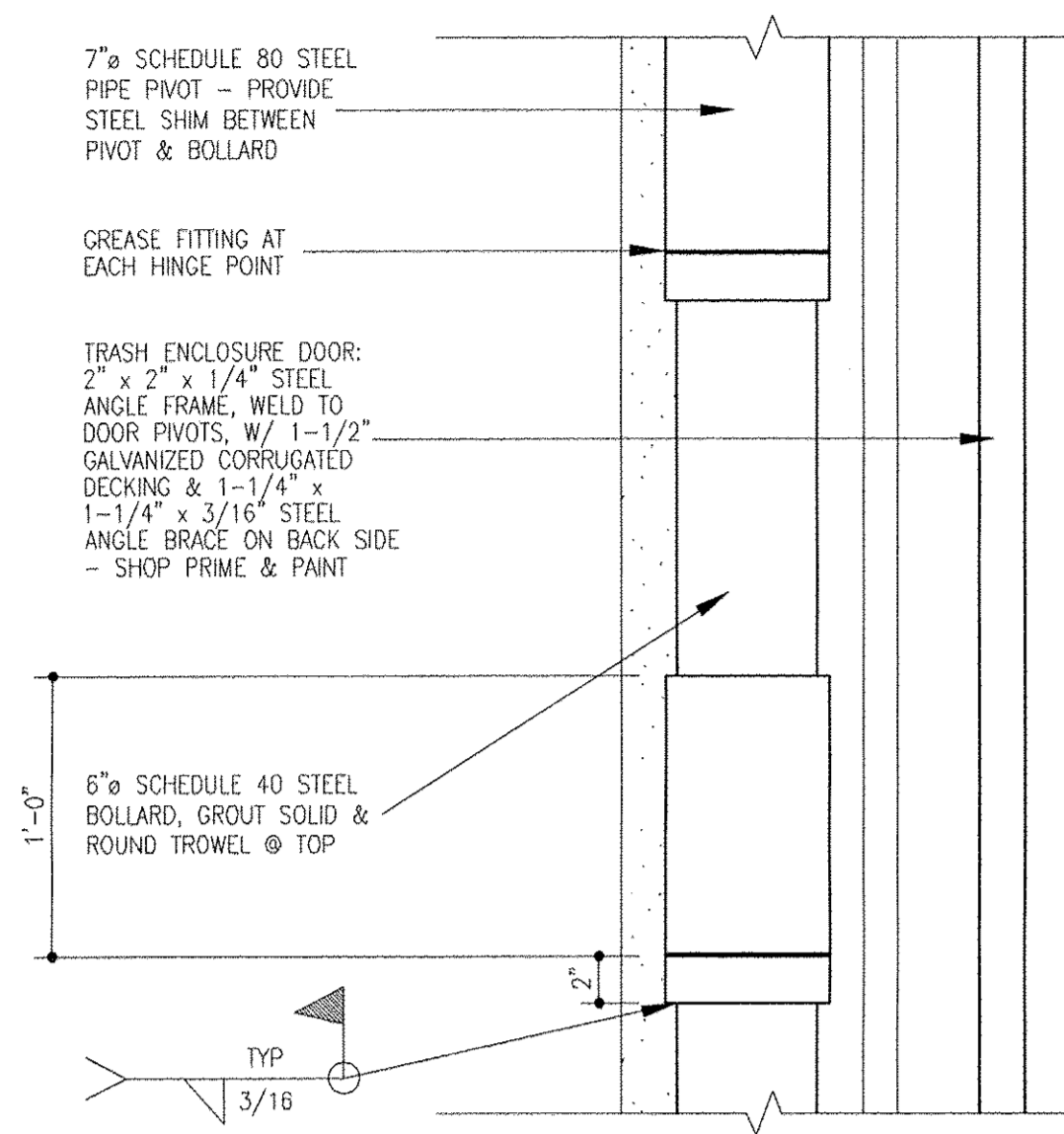

9 Dumpster Door Pivot
1 1/2" = 1'-0"

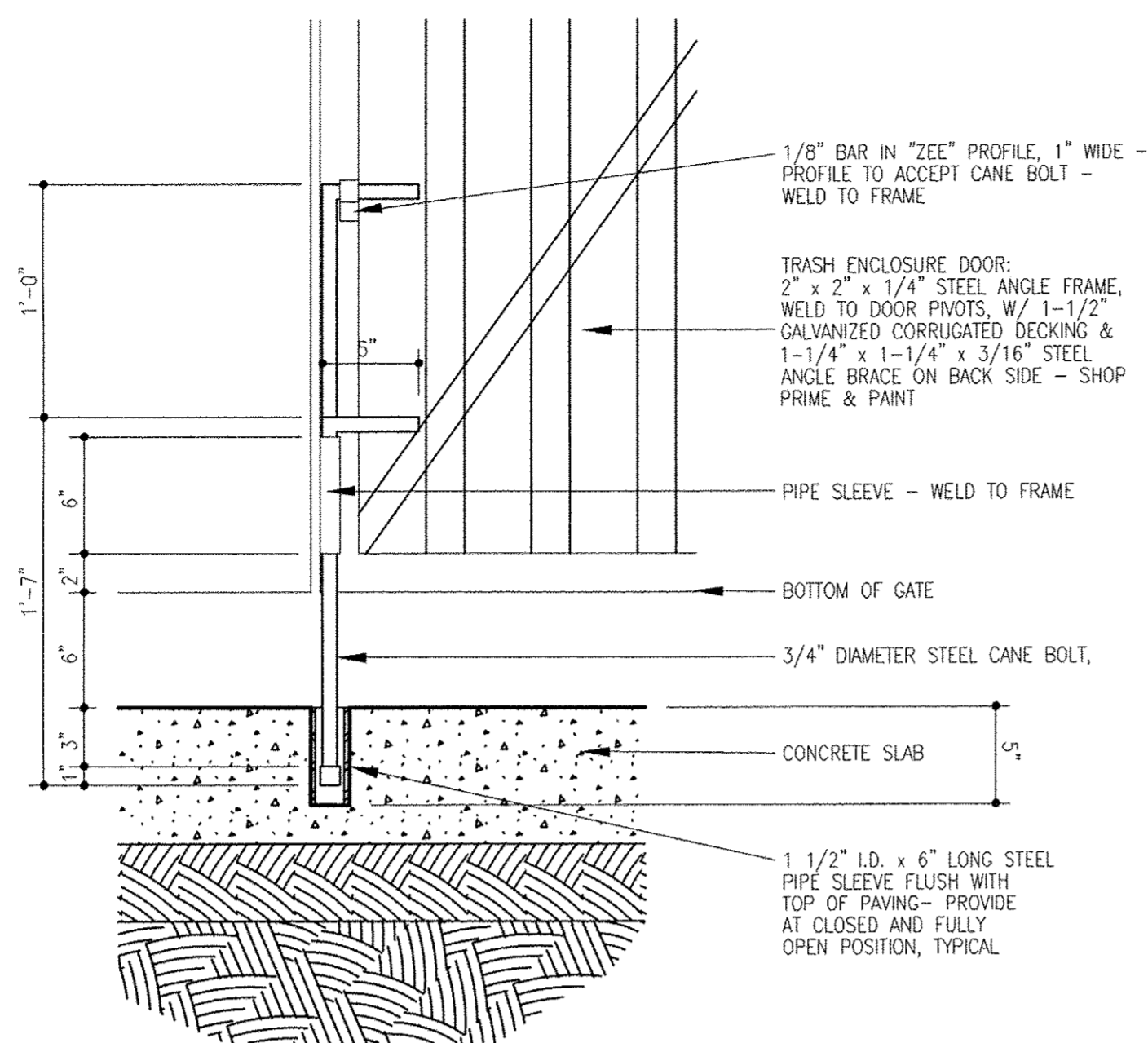

8 Cane Bolt Detail
1 1/2" = 1'-0"

General Notes

1. PAINT BOLLARDS, GATE HINGES, GATES & ANY OTHER FERROUS STEEL COMPONENT TO MATCH BUILDING

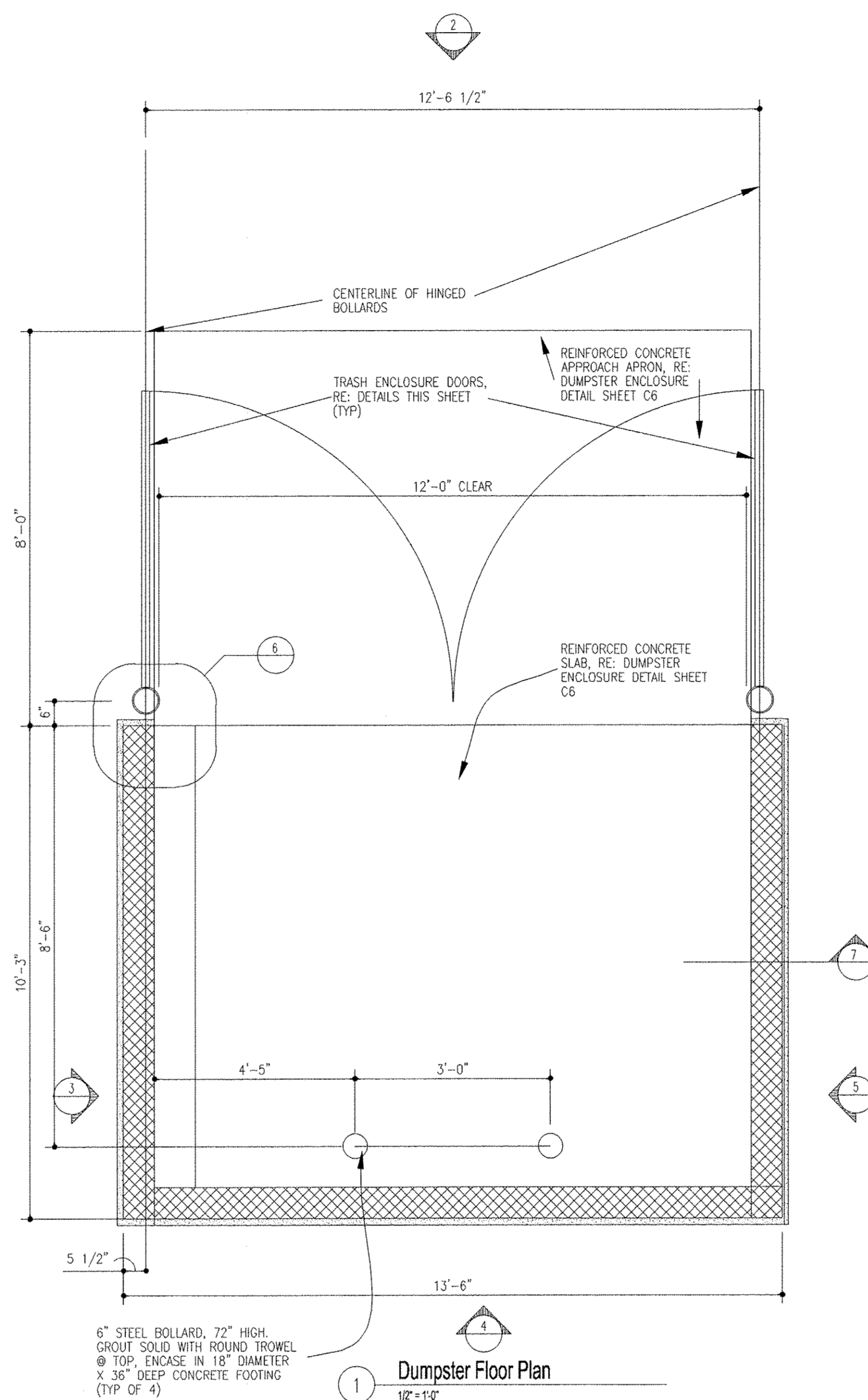

1 Dumpster Floor Plan
1/2" = 1'-0"

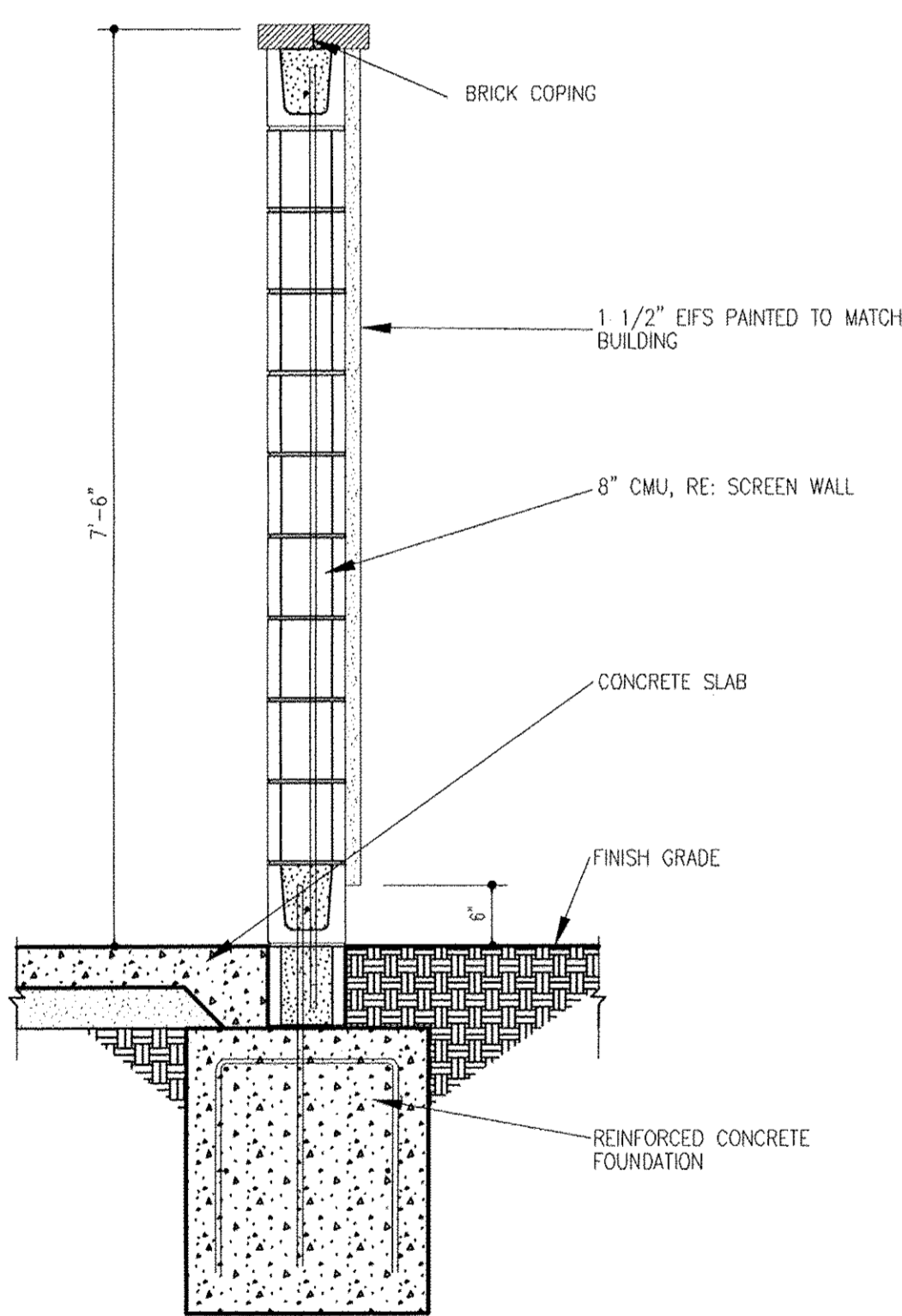

7 Wall Section
3/4" = 1'-0"

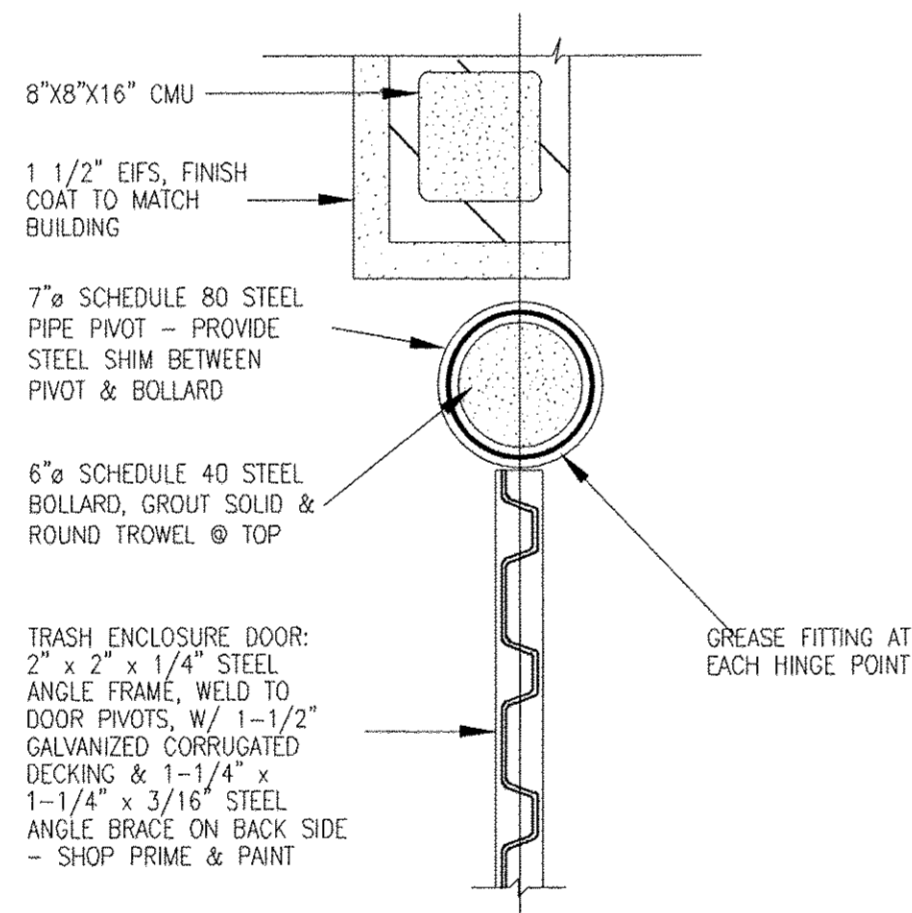

6 Plan Detail
1 1/2" = 1'-0"

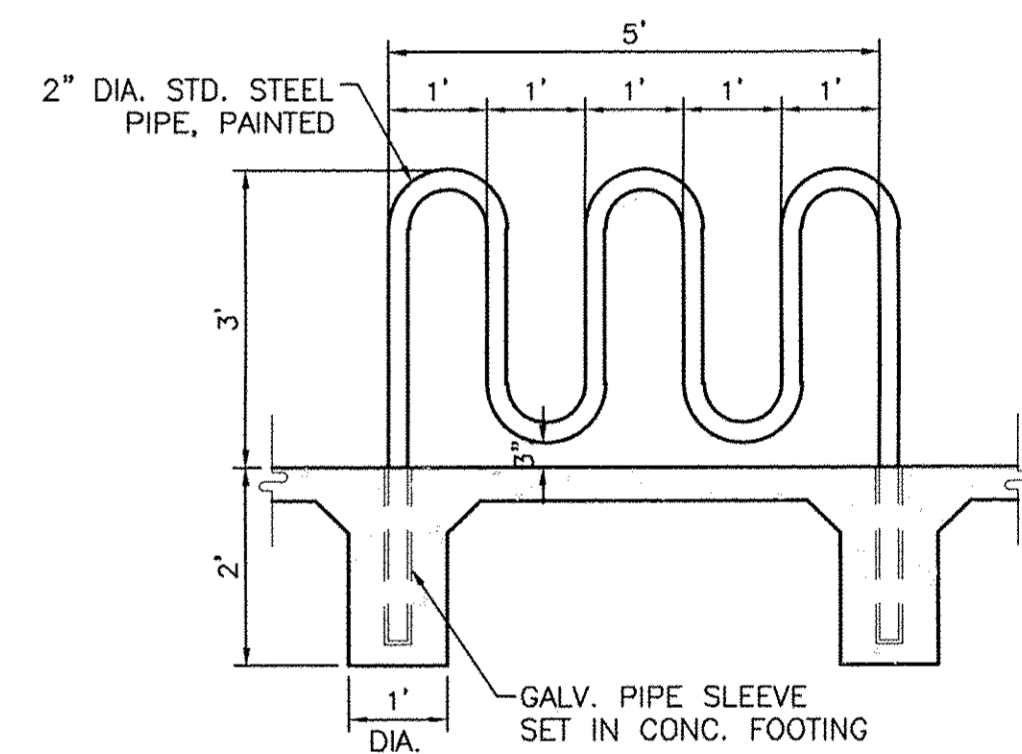

BIKE RACK DETAIL
SCALE: 1/2" = 1'-0"

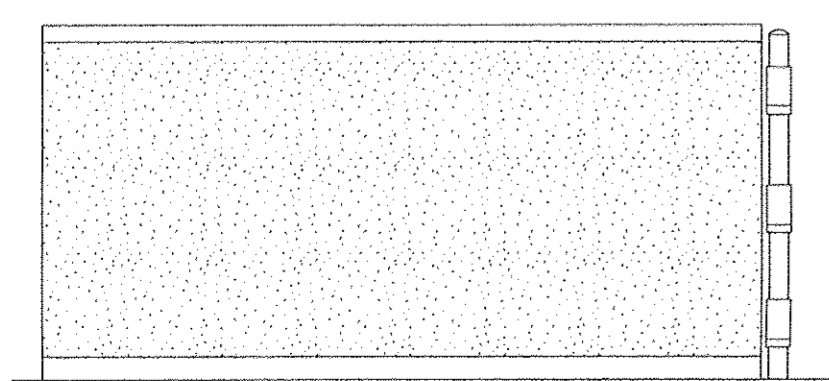

5 Side Elevation
NTS

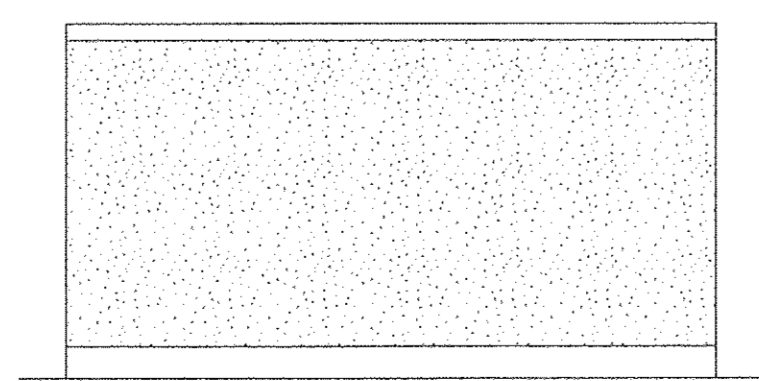

4 Back Elevation
NTS

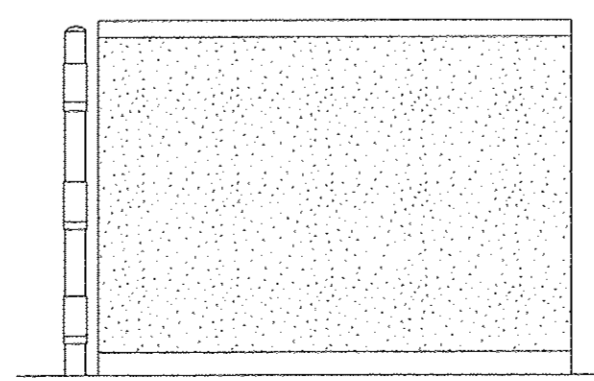

3 Side Elevation
NTS

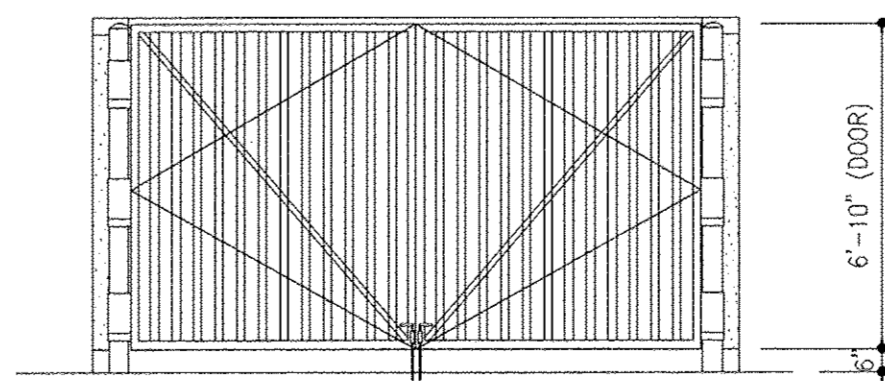

2 Front Elevation
NTS

	ENGINEER'S SEAL	UTILITY TRAILER SALES	DRAWN BY LA
		PROJECT LOCATION	DATE 02/26/2018
	DETAIL SHEET 01		2017041_SPE
			SHEET # C5
			JOB # 2017041
RONALD R. BOHANNAN P.E. #7868		TIERRA WEST, LLC 5571 MIDWAY PARK PLACE NE ALBUQUERQUE, NM 87109 (505) 858-3100 www.tierrawestllc.com	

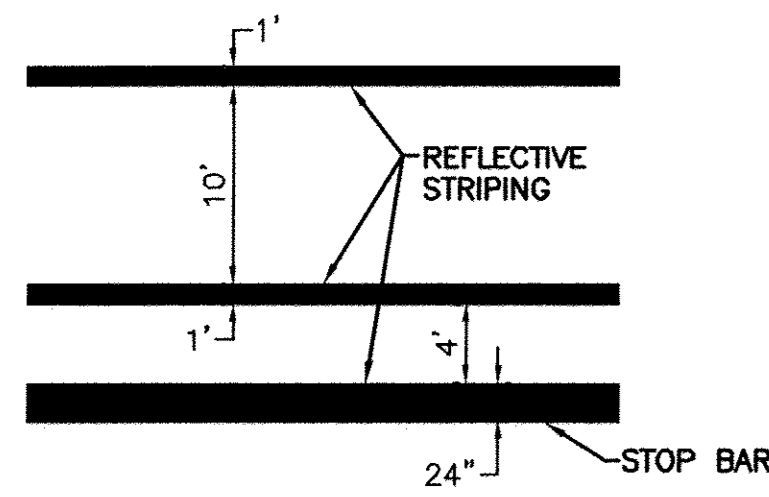

** ALL PAVEMENT MARKINGS SHALL CONFORM TO M.U.T.C.D. SPECS (LATEST EDITION)

CROSSWALK DETAIL
NTS

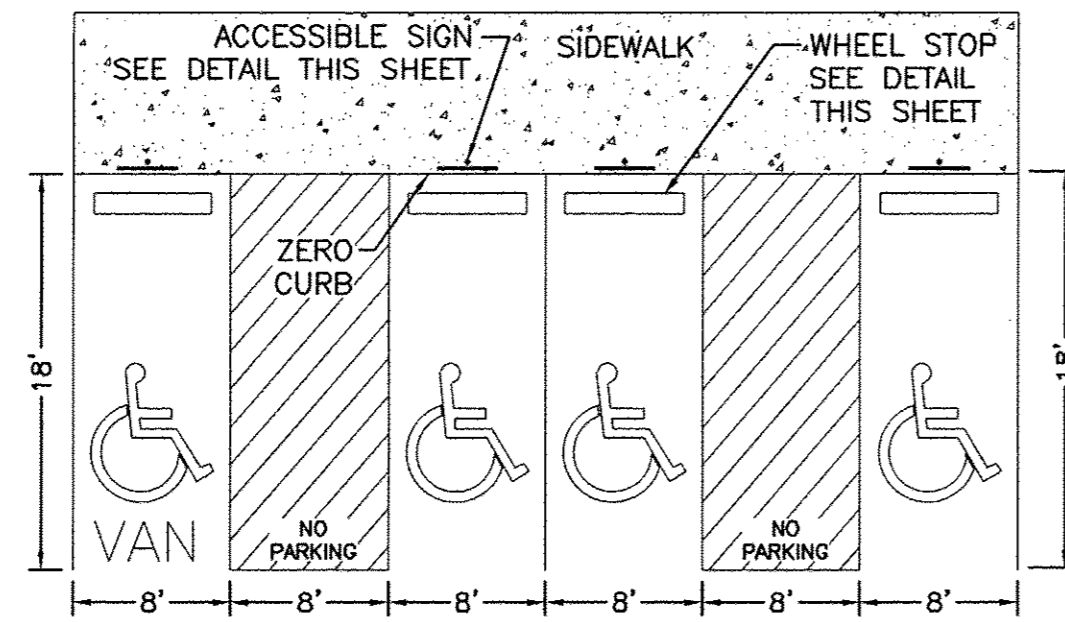

NOTES:
 1) International Symbol of Accessibility shall be painted on the pavement at rear of space, white symbol on blue background.
 2) Parking space lines and diagonal striping to be painted blue.
 3) Access aisle shall have the words "NO PARKING" in capital letters, each of which shall be at least one foot high and at least two inches wide, placed at the rear of the parking space so as to be close to where an adjacent vehicle's rear tires would be placed.

HC PARKING DETAIL
NTS

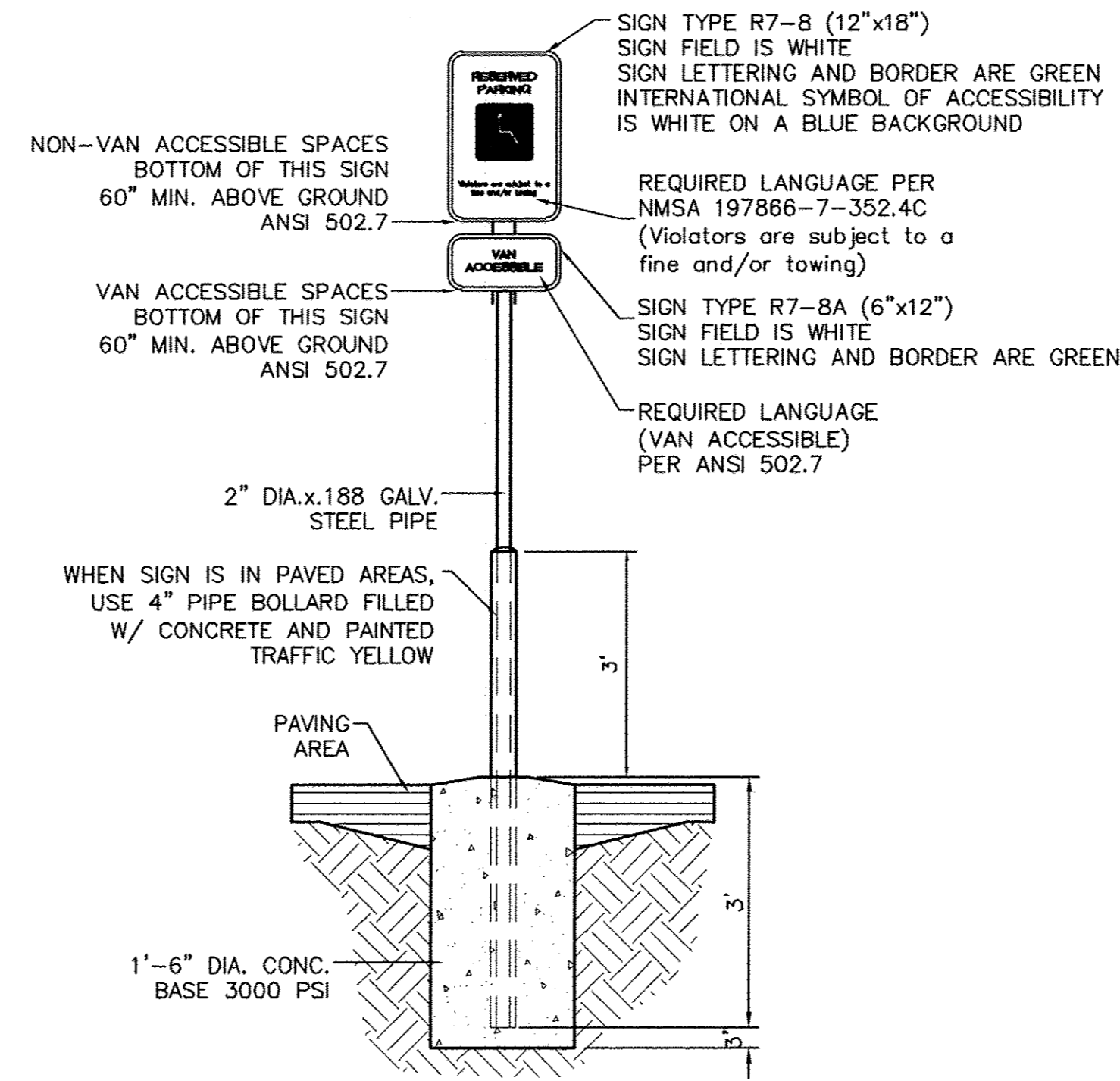

ACCESSIBLE PARKING SIGN
NTS

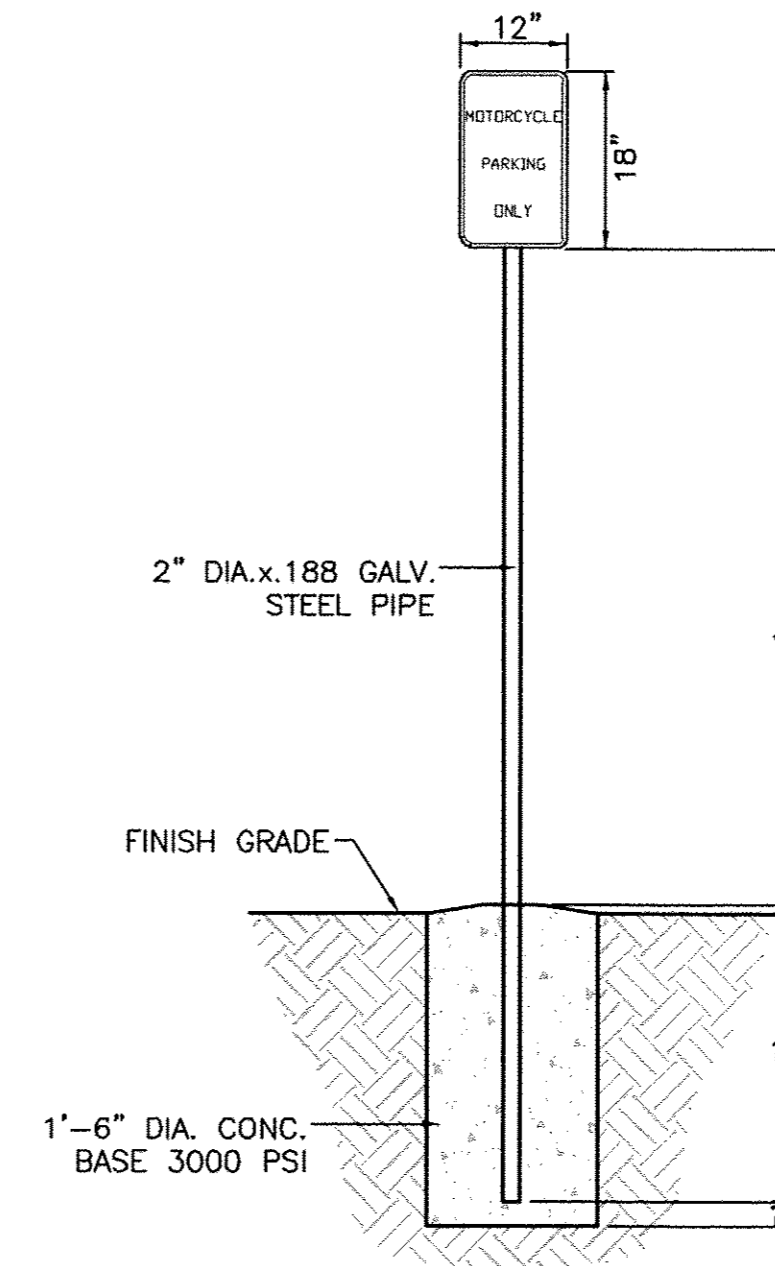

MOTORCYCLE PARKING SIGN
NTS

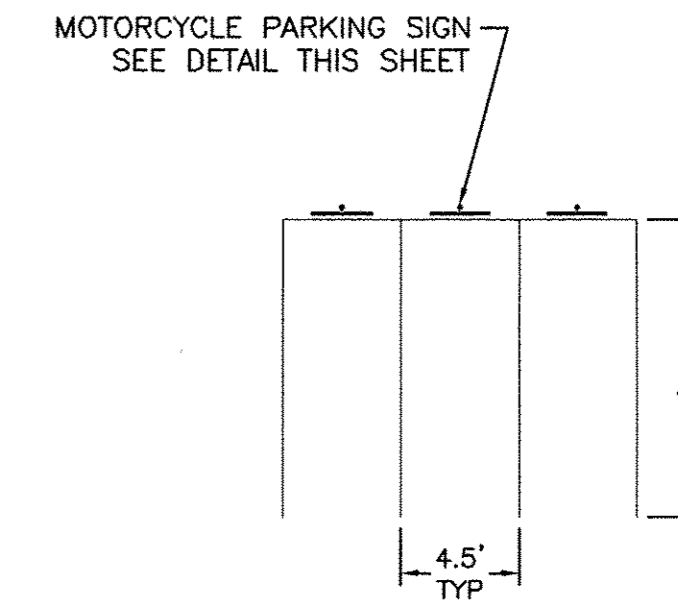

MOTORCYCLE PARKING DETAIL
NTS

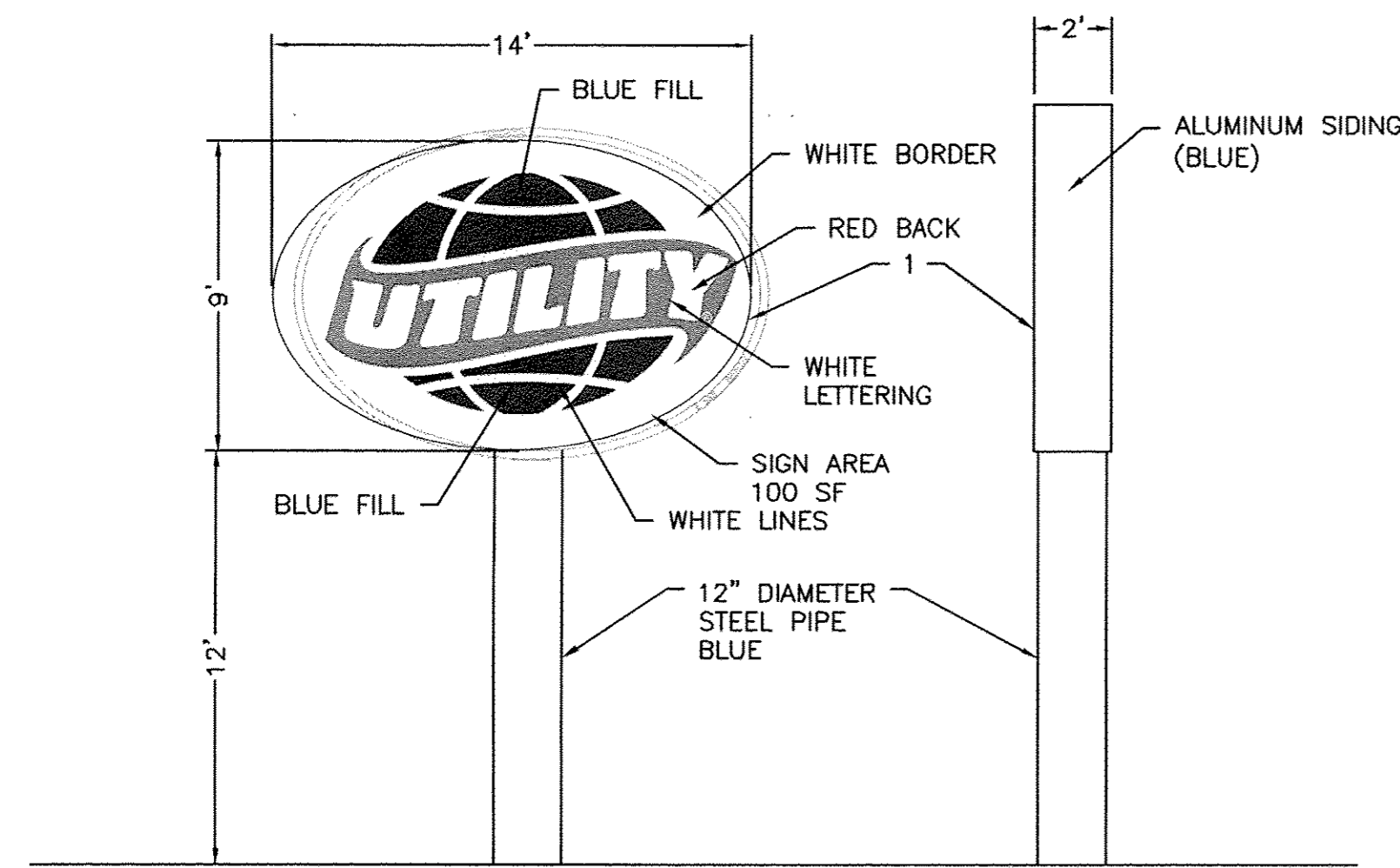

MONUMENT SIGN DETAIL
SCALE 1"=5'

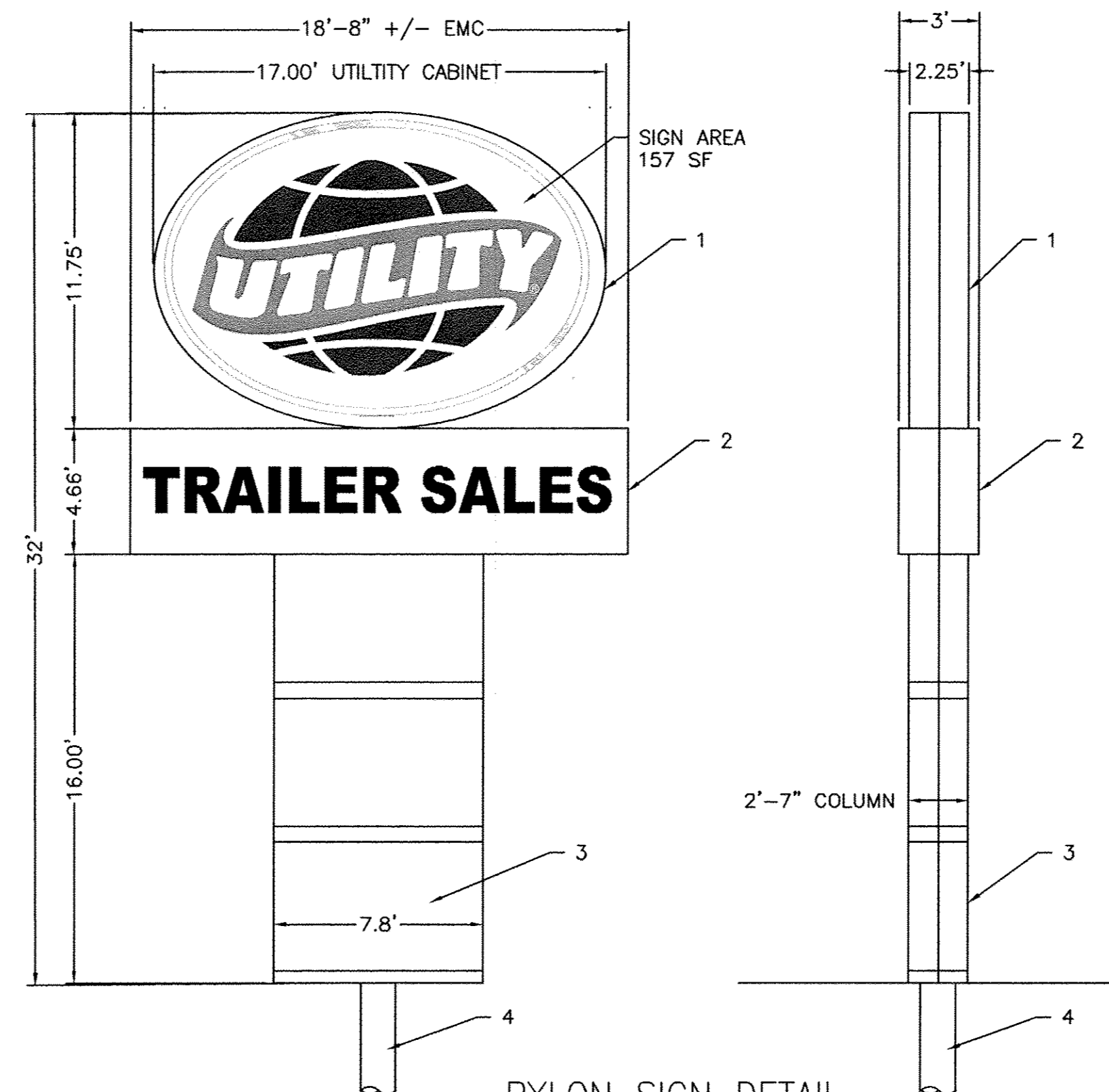

PYLON SIGN DETAIL
SCALE 1"=5'

- UTILITY LOGO CABINET: D/F ILLUMINATED CUSTOM FAB. CABINET
- EMC: D/F 89mm PITCH 16x64 MATRIX AMBER MONOCHROME EMC
 PRIMARY ELECTRICAL: 120V/240V-TOTAL SIGNS AMPS T.B.D.
 POWER OUT: LEAVE 8'-0" PIGTAIL WIRE INSIDE CAB FOR SIGN HOOK UP.
 POWER LOCATION: REFER TO M.E.P. DWGS
 SWITCH LOCATION: T.B.D.
- COLUMN: CUSTOM FABRICATED 1 1/2" ALUM. ANGLE FRAME COVERED ON ALL SIDES W/.090" THICK ALUM.
- MOUNTING PIPE: 8" +/- DIA. PIPE SLEAVED INSIDE 24" O.D. STD. STEEL PIPE SET IN CONCRETE CAISSON.

ENGINEER'S SEAL	UTILITY TRAILER SALES ALBUQUERQUE NM	DRAWN BY LA
	DETAIL SHEET 02	DATE 03/20/2018
		2017041_SPE 3
	TERRA WEST, LLC 5571 MIDWAY PARK PLACE NE ALBUQUERQUE, NM 87109 (505) 858-3100 www.tierrawestllc.com	SHEET # C6
RONALD R. BOHANNAN P.E. #7868		JOB # 2017041

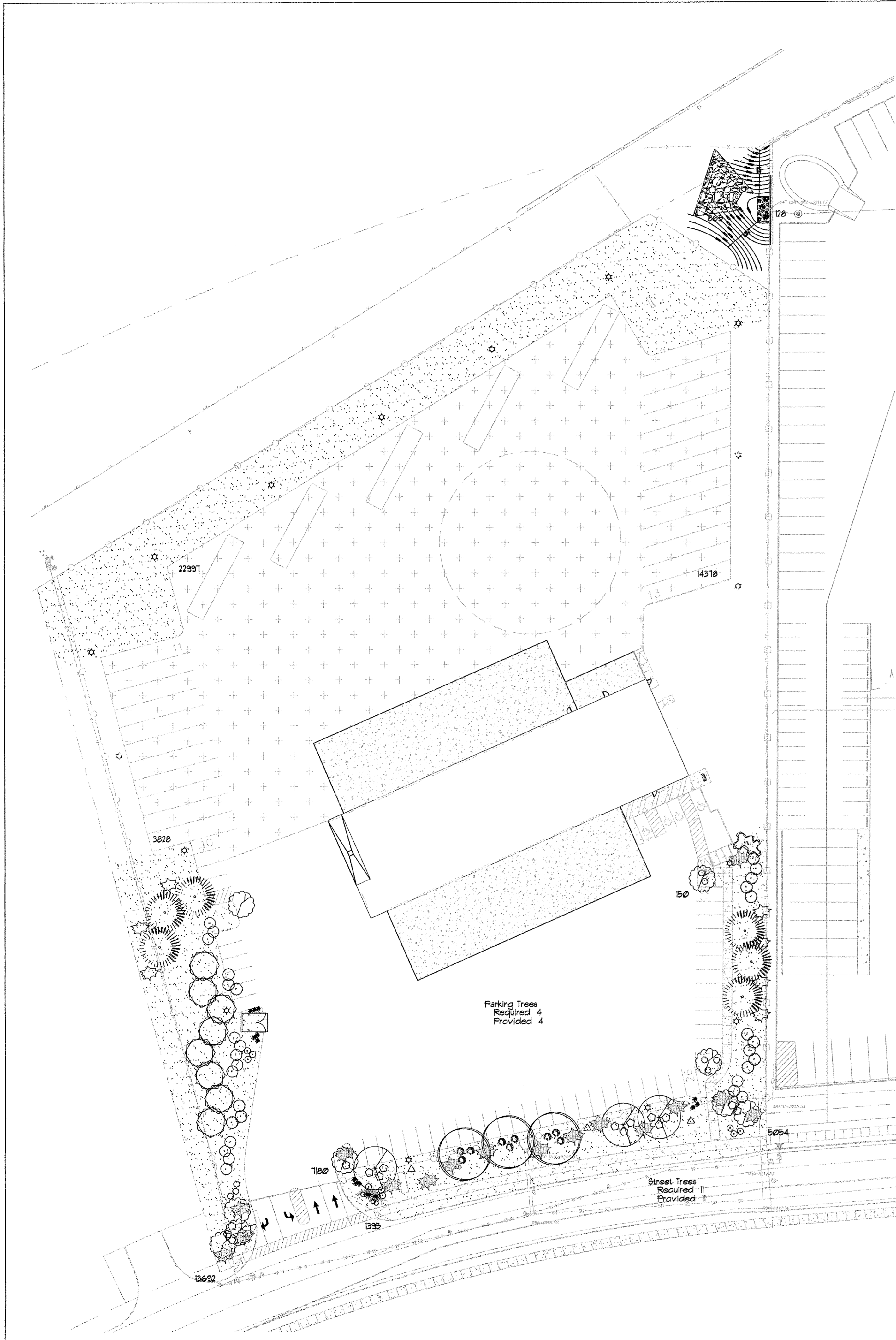

LANDSCAPE LEGEND

QTY	SIZE	COMMON/BOTANICAL	H2O USE
3	2" cal	Chinese Pistache <i>Pistacia chinensis</i>	M+
3	2" cal	Honey Locust <i>Gleditsia triacanthos</i>	M
6	6 - 8'	Austrian Pine <i>Pinus nigra</i>	M
1	15 Gal	Crape Myrtle <i>Lagerstroemia indica</i>	M
8	15 Gal	Desert Willow <i>Chilopsis linearis</i>	M
2	4 - 6'	Palm Yucca <i>Yucca faxoniana</i>	M
9	15 Gal	Bradford Pear <i>Pyrus calleryana</i>	M
9	5 Gal	India Hawthorn <i>Raphiolepis indica</i>	M
12	5 Gal	Feather Reed Grass <i>Calamagrostis arundinacea</i>	M
14	5 Gal	Wintergreen Barberry <i>Berberis juliana</i>	M
3	5 Gal	Butterfly Bush <i>Buddleia davidii</i>	M
16	5 Gal	Buffalo Juniper <i>Juniperus tamariscifolia 'Buffalo'</i>	M
1	5 Gal	Winter Jasmine <i>Juniperus tamariscifolia</i>	M
3	5 Gal	Cherry Sage <i>Salvia greggii</i>	M
9	5 Gal	Blue Mist <i>Caryopteris x clandonensis</i>	M
8	5 Gal	Turpentine Bush <i>Eriocameria laricifolia</i>	L
16	5 Gal	Apache Plume <i>Fallugia paradoxa</i>	L
15	5 Gal	Cornelia <i>Chrysothamnus nauseosus</i>	L
16	2-3cf	Boulders To be placed at contractor discretion 3/4" Crushed Gray Gravel/Filter Fabric	
50318		19193	
69511		2-4" Cobble	

LANDSCAPE NOTES:
Landscape maintenance shall be the responsibility of the Property Owner. The Property Owner shall maintain street trees in a living, healthy, and attractive condition.

It is the intent of this plan to comply with the City of Albuquerque, Landscape Ordinance. Approval of this plan does not constitute or imply exemption from water waste provisions of the Water Conservation Landscaping and Water Waste Ordinance.

Water management is the sole responsibility of the Property Owner. All landscaping will be in conformance with the City of Albuquerque Zoning Code. In general, water conservative, environmentally sound landscape principles will be followed in design and installation.

Landscape Gravel over Filter Fabric to a minimum depth of 3" shall be placed in all landscape areas which are not designated to receive native seed.

IRRIGATION NOTES:
Irrigation shall be a complete underground system with Trees to receive 1 Netafim spiral (50' length) with 3 loops at a final radius of 4.5' from tree trunk, pinned in place. Netafim shall have emitters 12" o.c. with a flow of 6 gph. Shrubs to receive (2) 1/8" GPH Drip Emitters. Drip and Bubblers systems to be tied to 1/2" poly pipe with flush caps at each end. Trees and shrubs shall be on separate valves.

Run time per each shrub drip valve will be approximately 15 minutes per day. Tree drip valve shall run 15 hours, 3 times per week. Run time will be adjusted according to the season.

Point of connection for irrigation system is unknown at current time and will be coordinated in the field. Irrigation will be operated by automatic controller.

Location of controller to be field determined and power source for controller to be provided by others.

Irrigation maintenance shall be the responsibility of the Property Owner.

Water and Power source shall be the responsibility of the Developer/Builder.

LANDSCAPE CALCULATIONS

TOTAL LOT AREA (sf)	240578
TOTAL BUILDING AREA (sf)	15635
TOTAL LOT AREA (sf)	224943
LANDSCAPE REQUIREMENT	X .15
TOTAL LANDSCAPE REQUIRED (15%)	33741
TOTAL ON-SITE LANDSCAPE PROVIDED	14881
TOTAL REVEG NATIVE SEED	44475
TOTAL LANDSCAPED AREA	30376
TOTAL LIVE PLANT MATERIAL PROVIDED	21625
TOTAL GROUND COVER PROVIDED	5958

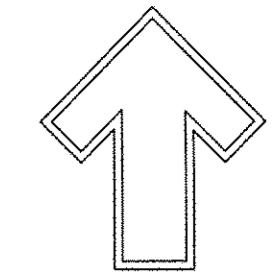
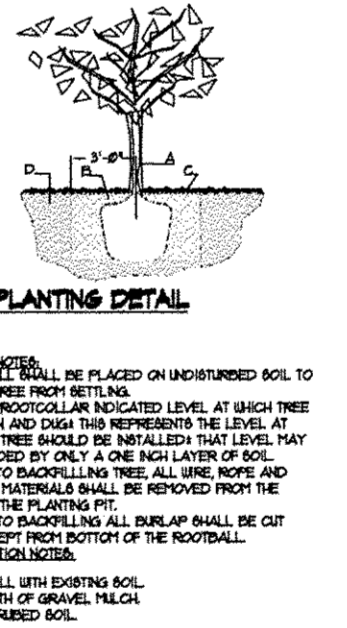
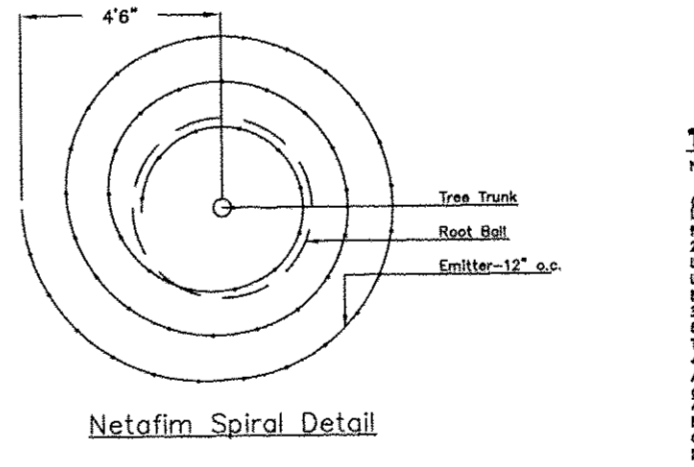
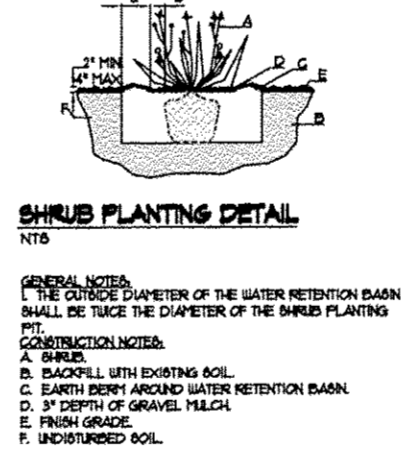
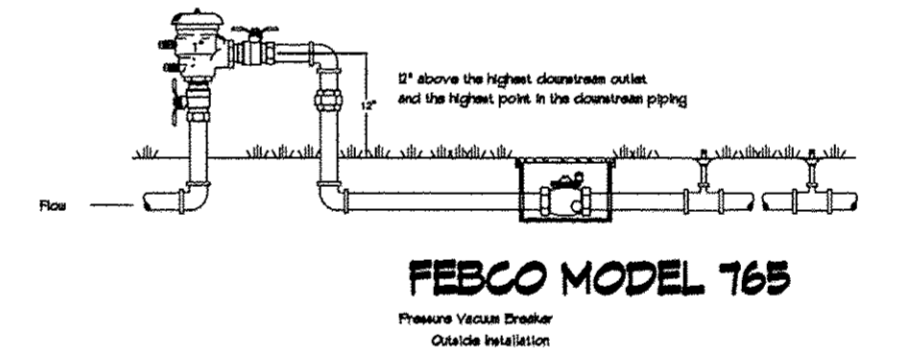
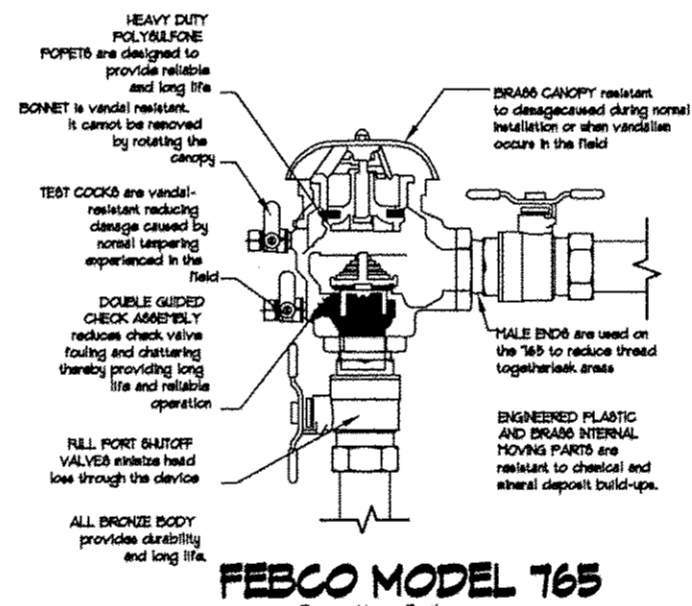

The Hilltop
1909 Edith NE
Albuquerque, NM 87113
Cell: 505-466-4558
Ph: (505) 898-3630
Fax: (505) 898-1131
danny@hilltoplandscaping.com

Landscape Architect



Utility Trailer Sales
Albuquerque, NM
LANDSCAPE PLAN

The design contained herein is the property of The Hilltop Landscaping Architects and Contractors and is protected by copyright law. This is an original design and must not be reproduced or used for any other project without the express written consent of The Hilltop Landscaping Architects & Contractors. All fees have been paid for a job order placed.

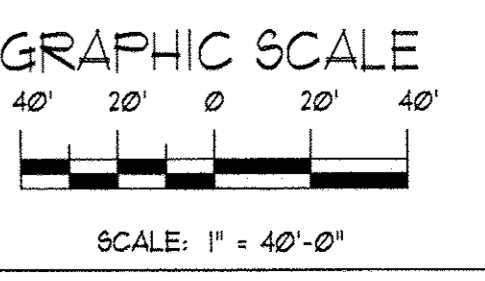
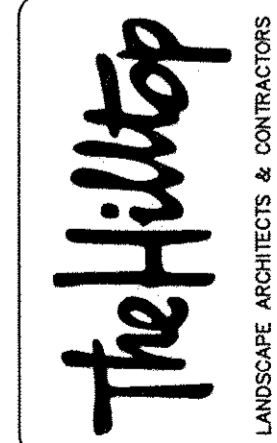

DRAWN BY: CA
REVISION: 1
03/2018
5/8/2018
DATE: 5/8/2018
SHEET: LS-101