

1 TYPICAL SIDEWALK DETAIL N.T.S.

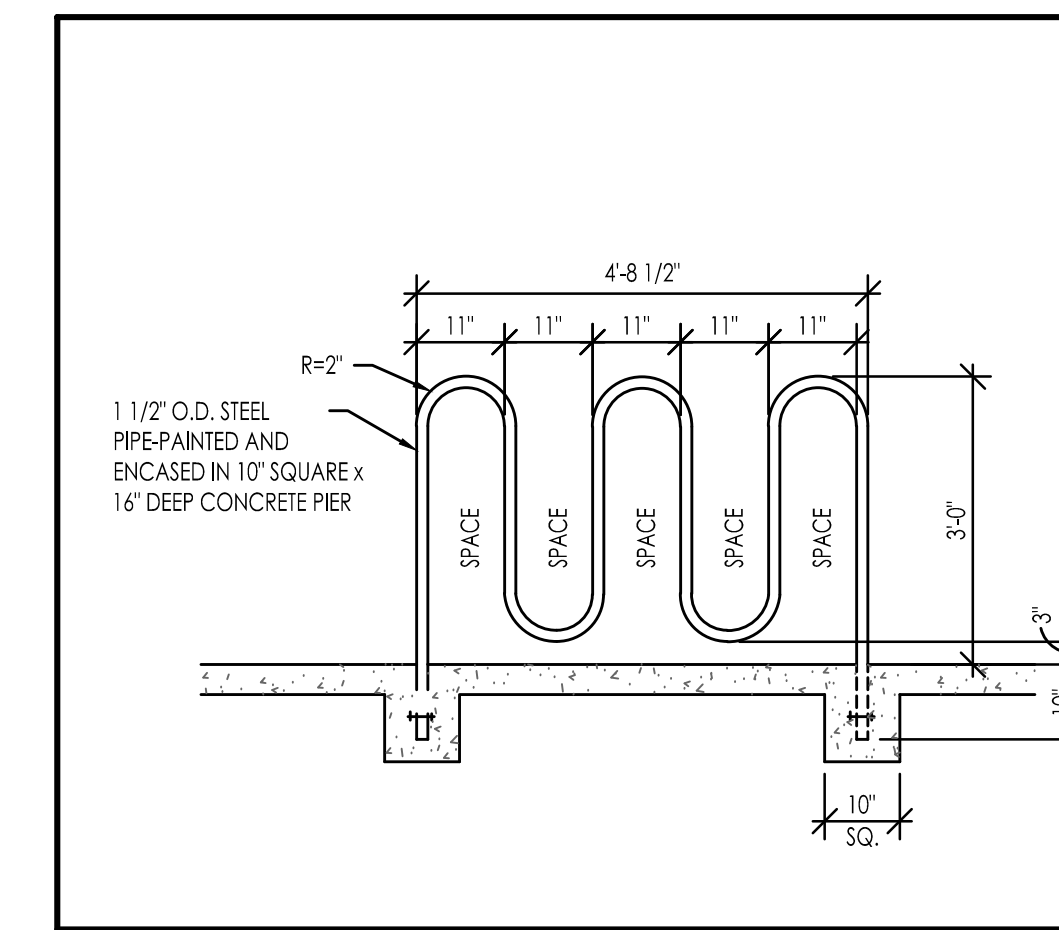

2 BIKE RACK ELEVATION 1/2"=1'-0"

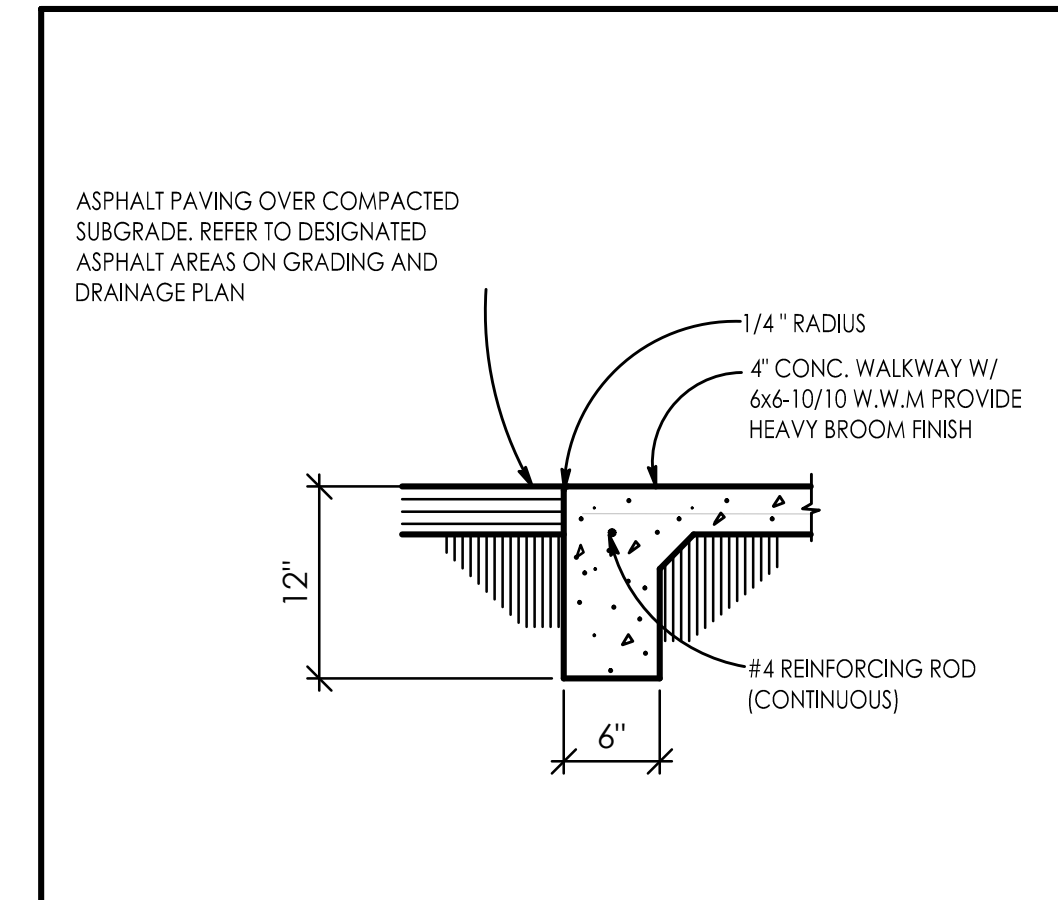

3 TYPICAL CONCRETE CURB & SIDEWALK DETAIL N.T.S.

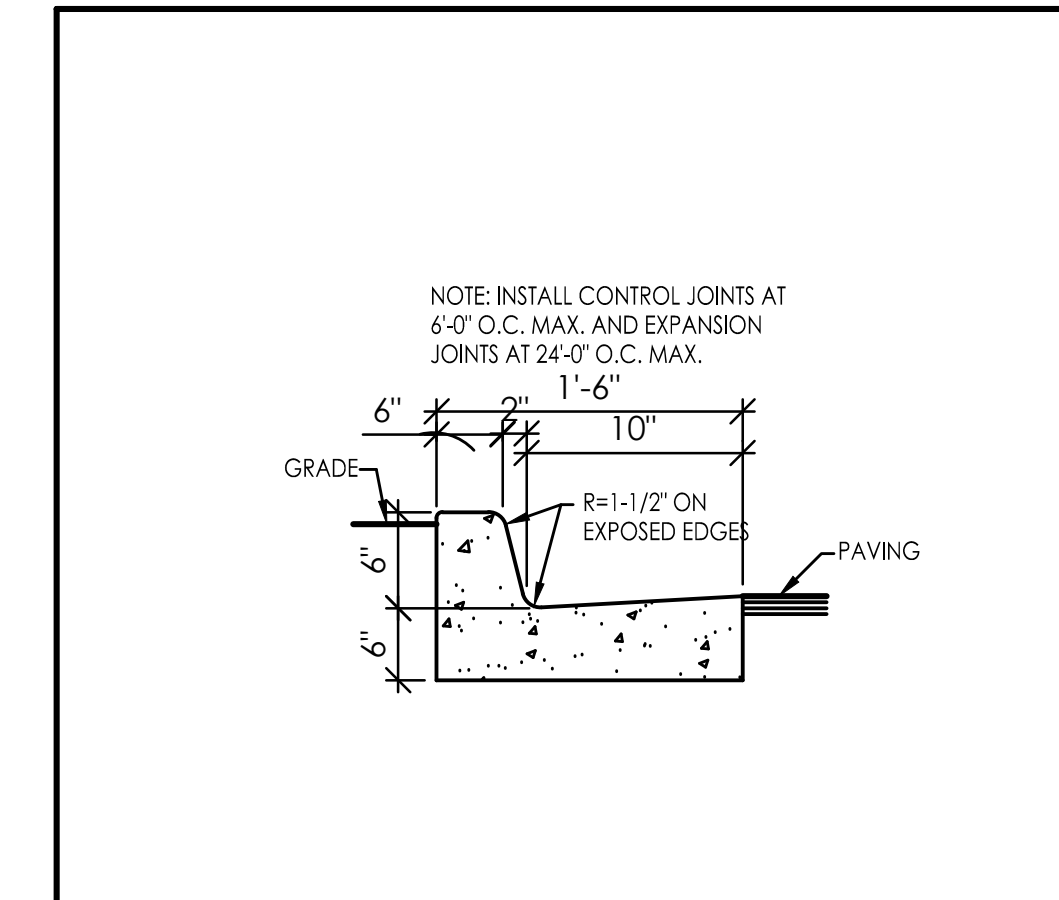

4 CONCRETE CURB & GUTTER DETAIL N.T.S.

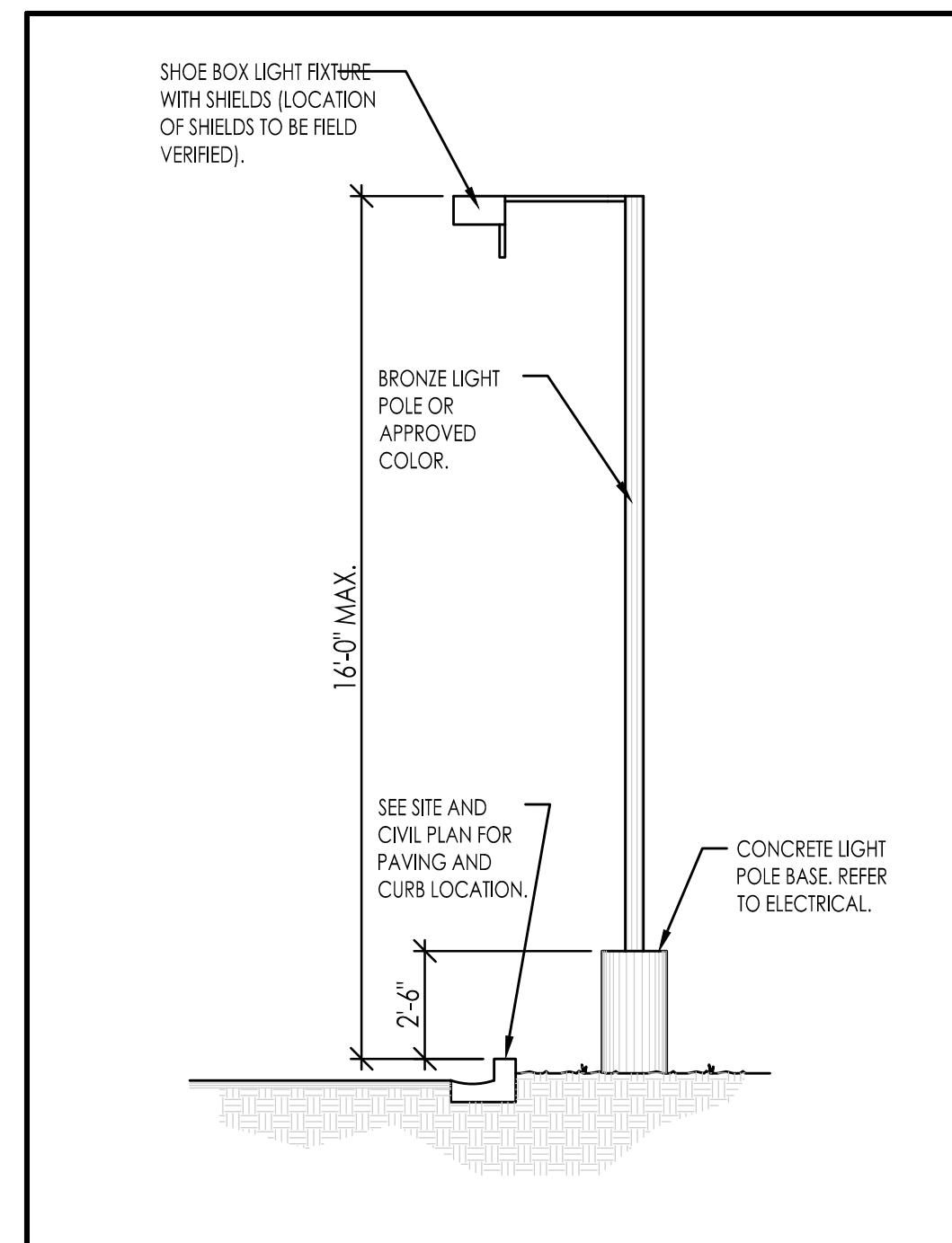

5 HANDICAP RAMP ISOMETRIC 1/4"=1'-0"

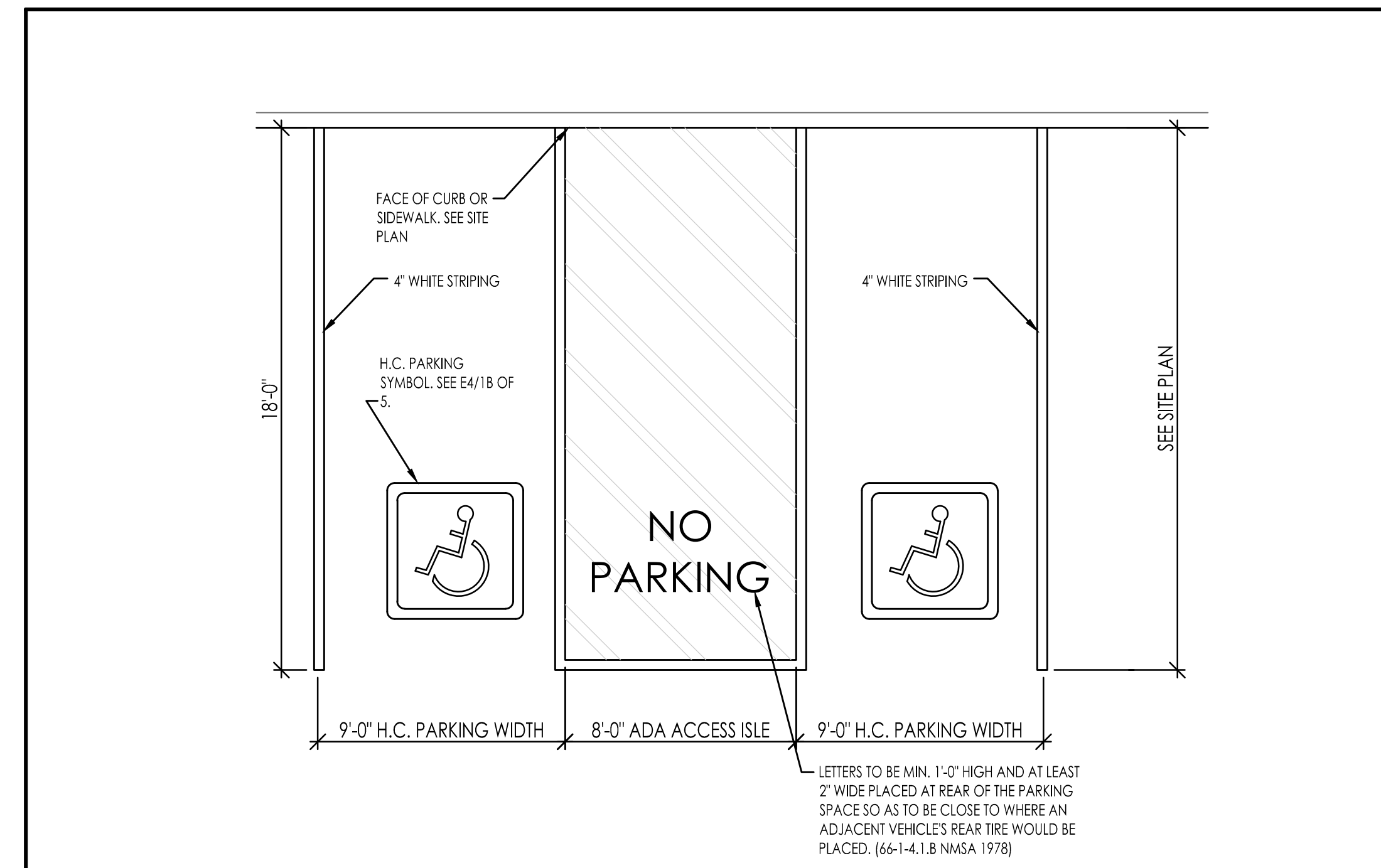

6 HC PARKING STRIPING PLAN 1/4"=1'-0"

INNOVA PLAZA - PHASE 2
SITE DETAILS
401 EUBANK SE, ALBUQUERQUE, NM 87123
PROJECT # 1609

REVISION DATE

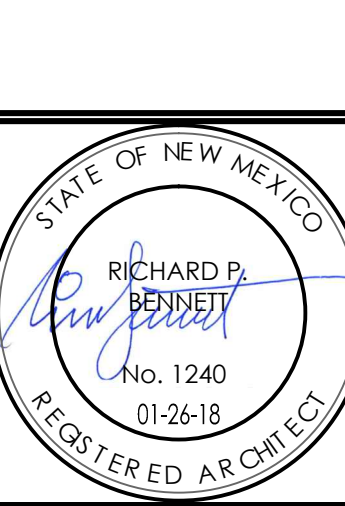

DATE
01-26-18

SHEET NUMBER
AS-2