

PLAT OF
**TRACT A, BLOCK 18, PERFECTO
 ARMIJO AND BROTHERS ADDITION**
 A REPLAT OF LOTS 223, 224 AND A PORTION OF LOTS 225-228,
 BLOCK 18, PERFECTO ARMIJO AND BROTHERS ADDITION
 WITHIN PROJECTED SECTION 17, T. 10 N., R. 3 E., N.M.P.M.
 WITHIN THE TOWN OF ALBUQUERQUE GRANT
 ALBUQUERQUE, BERNALILLO COUNTY, NEW MEXICO
 MARCH 2016

COUNTY CLERK RECORDING LABEL HERE

ACS MONUMENT "17-J14"
 X=1,519,149.317
 Y=1,488,866.762
 Ground-to-grid: 0.999683611
 Mapping Angle: -00°13'59.00"
 NMSP CENTRAL ZONE NAD 83

LOMAS BOULEVARD, N.E.
 (100' R.O.W.)

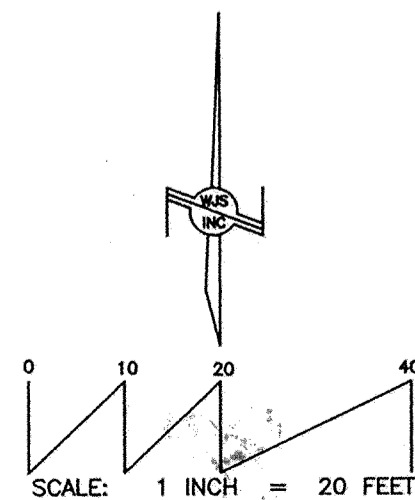
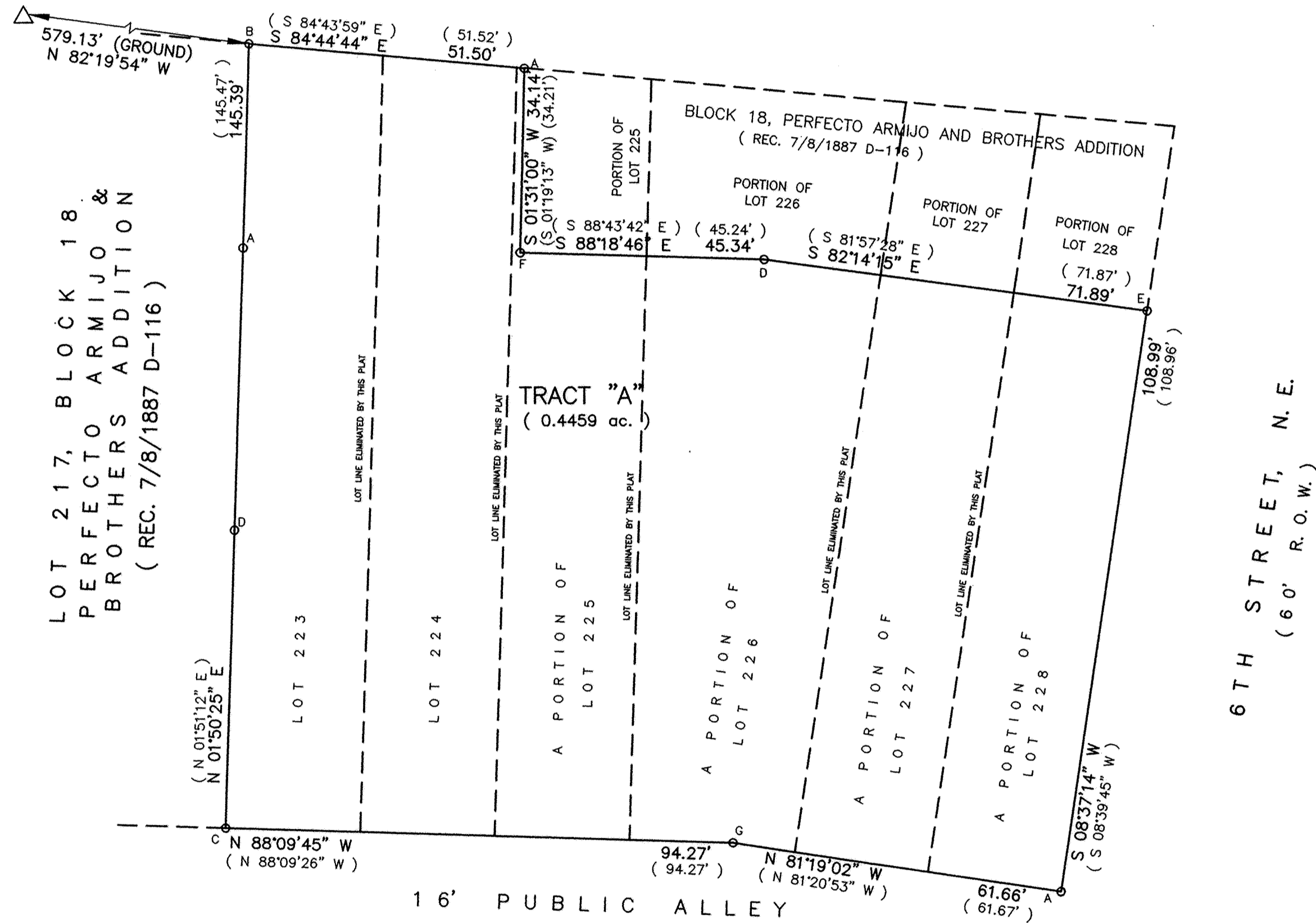

- FOUND/SET MONUMENT LEGEND:
 A: FOUND #4 REBAR AND CAP "PS 15702"
 B: FOUND NAIL AND DISK "PS 15702"
 C: FOUND #4 REBAR AND CAP "LS 9750"
 D: FOUND #4 REBAR - NO CAP
 E: FOUND "+" IN CONCRETE
 F: FOUND #4 REBAR AND CAP "LS 12551"
 G: SET #4 REBAR AND CAP "PS 14269"

	330 LOUISIANA BLVD., N.E. ALBUQUERQUE, N.M. 87108 PHONE: (505) 255-2052 FAX: (505) 255-2887		
INDEXING INFORMATION FOR COUNTY CLERK OWNER: DOUGLAS PETERSON INVESTMENTS INC. LOCATION: SEC. 17, T.10 N., R.3 E., PERFECTO ARMIJO AND BROS. ADDITION	DRAWN: T R J CHECKED: T D J DRAWING NO. SP30116.DWG	SCALE: 1" = 20' 9 MAR 2016	FILE NO. SP-3-01-2016 SHEET 2 OF 2