

Courtyard I
7500 Jefferson St. NE
Albuquerque, NM
87109-4335
www.bhinc.com
voice: 505.823.1000
facsimile: 505.798.7988
toll free: 800.877.5332

CLIENT/COURIER TRANSMITTAL

To: Mr. Jack Cloud, DRB Chair
City of Albuquerque
Planning Department
600 2nd Street NW
Albuquerque, NM 87103

Requested by: Michael Balaskovits

Date: April 25, 2017

Time Due: This A.M.
 This P.M.
 Rush _____
 By Tomorrow _____

Phone: (505) 924-3880

Job No.: 20160155

Job Name: Highlands

DELIVERY VIA

- Courier Federal Express
 Mail UPS
 Other

PICK UP

Item: _____

<u>ITEM NO.</u>	<u>QUANTITY</u>	<u>DESCRIPTION</u>
1	1	DRB Application
2	1	Form S(3)
3	1	Certificate of No Effect
4	6	Final Plat
5	3	Existing R/W Cross Sections
6	6	Existing Site Sketch
7	1	Zone Atlas Map

COMMENTS / INSTRUCTIONS

Jack,

Please find attached the Final Plat for the Highlands development. Let me know if you have any questions.

Thanks,
Mike

REC'D BY: _____ DATE: _____ TIME: _____

FORM S(3): SUBDIVISION - D.R.B. MEETING (UNADVERTISED) OR INTERNAL ROUTING

A **Bulk Land Variance** requires application on FORM-V in addition to application for subdivision on FORM-S.

SKETCH PLAT REVIEW AND COMMENT (DRB22) **Your attendance is required.**

- Scale drawing of the proposed subdivision plat (folded to fit into an 8.5" by 14" pocket) **6 copies**
- Site sketch with measurements showing structures, parking, Bldg. setbacks, adjacent rights-of-way and street improvements, if there is any existing land use (folded to fit into an 8.5" by 14" pocket) **6 copies**
- Zone Atlas map with the entire property(ies) clearly outlined
- Letter briefly describing, explaining, and justifying the request
- List any original and/or related file numbers on the cover application

EXTENSION OF MAJOR PRELIMINARY PLAT (DRB08) **Your attendance is required.**

- Preliminary Plat reduced to 8.5" x 11"
 - Zone Atlas map with the entire property(ies) clearly outlined
 - Letter briefly describing, explaining, and justifying the request
 - Copy of DRB approved infrastructure list
 - Copy of the LATEST Official DRB Notice of approval for Preliminary Plat Extension request
 - List any original and/or related file numbers on the cover application
- Extension of preliminary plat approval expires after one year.**

MAJOR SUBDIVISION FINAL PLAT APPROVAL (DRB12) **Your attendance is required.**

- Proposed Final Plat (folded to fit into an 8.5" by 14" pocket) **6 copies**
- Signed & recorded Final Pre-Development Facilities Fee Agreement for **Residential** development only
- Design elevations & cross sections of perimeter walls **3 copies**
- Zone Atlas map with the entire property(ies) clearly outlined
- Bring original Mylar of plat to meeting, ensure property owner's and City Surveyor's signatures are on the plat
- Copy of recorded SIA
- Landfill disclosure and EHD signature line on the Mylar if property is within a landfill buffer
- List any original and/or related file numbers on the cover application
- DXF file and hard copy of final plat data for AGIS is required.

MINOR SUBDIVISION PRELIMINARY/FINAL PLAT APPROVAL (DRB16) **Your attendance is required.**

- 5 Acres or more: Certificate of No Effect or Approval
- Proposed Preliminary / Final Plat (folded to fit into an 8.5" by 14" pocket) **6 copies** for unadvertised meetings ensure property owner's and City Surveyor's signatures are on the plat prior to submittal
- Signed & recorded Final Pre-Development Facilities Fee Agreement for **Residential** development only
- Design elevations and cross sections of perimeter walls (11" by 17" maximum) **3 copies**
- Site sketch with measurements showing structures, parking, Bldg. setbacks, adjacent rights-of-way and street improvements, if there is any existing land use (folded to fit into an 8.5" by 14" pocket) **6 copies**
- Zone Atlas map with the entire property(ies) clearly outlined
- Letter briefly describing, explaining, and justifying the request
- Bring original Mylar of plat to meeting, ensure property owner's and City Surveyor's signatures are on the plat
- Landfill disclosure and EHD signature line on the Mylar if property is within a landfill buffer
- Fee (see schedule)
- List any original and/or related file numbers on the cover application
- Infrastructure list if required (**verify with DRB Engineer**)
- DXF file and hard copy of final plat data for AGIS is required.

AMENDMENT TO PRELIMINARY PLAT (with minor changes) (DRB03) **Your attendance is required.**

- PLEASE NOTE: There are no clear distinctions between significant and minor changes with regard to subdivision amendments. Significant changes are those deemed by the DRB to require public notice and public hearing.
- Proposed Amended Preliminary Plat, Infrastructure List, and/or Grading Plan (folded to fit into an 8.5" by 14" pocket) **6 copies**
 - Original Preliminary Plat, Infrastructure List, and/or Grading Plan (folded to fit into an 8.5" by 14" pocket) **6 copies**
 - Zone Atlas map with the entire property(ies) clearly outlined
 - Letter briefly describing, explaining, and justifying the request
 - Bring original Mylar of plat to meeting, ensure property owner's and City Surveyor's signatures are on the plat
 - List any original and/or related file numbers on the cover application
- Amended preliminary plat approval expires after one year**

I, the applicant, acknowledge that any information required but not submitted with this application will likely result in deferral of actions.

Michael Balaskovits
 Applicant name (print)
M. Balaskovits 4/24/17
 Applicant signature / date



Form revised **October 2007**

- | | |
|----------------------------------------------|--------------------------|
| <input type="checkbox"/> Checklists complete | Application case numbers |
| <input type="checkbox"/> Fees collected | _____ - _____ - _____ |
| <input type="checkbox"/> Case #s assigned | _____ - _____ - _____ |
| <input type="checkbox"/> Related #s listed | _____ - _____ - _____ |

_____ Planner signature / date
 Project # _____



SUBDIVISION

- Major subdivision action
- Minor subdivision action
- Vacation
- Variance (Non-Zoning)

SITE DEVELOPMENT PLAN

- for Subdivision
- for Building Permit
- Administrative Amendment (AA)
- Administrative Approval (DRT, URT, etc.)
- IP Master Development Plan
- Cert. of Appropriateness (LUCC)

STORM DRAINAGE (Form D)

- Storm Drainage Cost Allocation Plan

Supplemental Form (SF)

- | | | |
|--------------------------|-----------------------------------------------------------------------------------|--------------------------------------------------------------------------------------------------|
| S | Z | ZONING & PLANNING |
| <input type="checkbox"/> | <input type="checkbox"/> | Annexation |
| V | <input type="checkbox"/> | Zone Map Amendment (Establish or Change Zoning, includes Zoning within Sector Development Plans) |
| P | <input type="checkbox"/> | Adoption of Rank 2 or 3 Plan or similar |
| <input type="checkbox"/> | <input type="checkbox"/> | Text Amendment to Adopted Rank 1, 2 or 3 Plan(s), Zoning Code, or Subd. Regulations |
| D | <input type="checkbox"/> | Street Name Change (Local & Collector) |
| L A | APPEAL / PROTEST of... | |
| <input type="checkbox"/> | Decision by: DRB, EPC, LUCC, Planning Director, ZEO, ZHE, Board of Appeals, other | |

PRINT OR TYPE IN BLACK INK ONLY. The applicant or agent must submit the completed application in person to the Planning Department Development Services Center, 600 2nd Street NW, Albuquerque, NM 87102. Fees must be paid at the time of application. Refer to supplemental forms for submittal requirements.

APPLICATION INFORMATION:

Professional/Agent (if any): BOHANNAN HUSTON, INC. (MIKE BALASKOVITS) PHONE: 505-823-1000
 ADDRESS: 7500 JEFFERSON ST. NE FAX: 505-798-7988
 CITY: ALBUQUERQUE STATE NM ZIP 87109 E-MAIL: MBALASKOVITS@BHINC.COM
 APPLICANT: TITAN DEVELOPMENT CENTER LAND, LLC PHONE: 505-998-0163
 ADDRESS: 6300 RIVERSIDE PLAZA LANE NW #200 FAX: _____
 CITY: ALBUQUERQUE STATE NM ZIP 87120 E-MAIL: bpatterson@titan-development.com
 Proprietary interest in site: DEVELOPER List all owners: _____

DESCRIPTION OF REQUEST: FINAL PLAT

Is the applicant seeking incentives pursuant to the Family Housing Development Program? Yes. No.

SITE INFORMATION: ACCURACY OF THE EXISTING LEGAL DESCRIPTION IS CRUCIAL! ATTACH A SEPARATE SHEET IF NECESSARY.

Lot or Tract No. BLOCKS 3, 4, 5, 6, & 21 Block: _____ Unit: _____
 Subdiv/Addn/TBKA: BROWNWELL & LAIL'S HIGHLAND ADDITION
 Existing Zoning: SU-2 Proposed zoning: N/A MRGCD Map No. _____
 Zone Atlas page(s): K-15-Z UPC Code: _____

CASE HISTORY:

List any current or prior case number that may be relevant to your application (Proj., App., DRB-, AX_Z_, V_, S_, etc.): DRB#1010879

CASE INFORMATION:

Within city limits? Yes Within 1000FT of a landfill? NO
 No. of existing lots: 56 No. of proposed lots: 6 Total site area (acres): APPROX. 11.6 ACRES
 LOCATION OF PROPERTY BY STREETS: On or Near: NORTHEAST CORNER OF CENTRAL AND INTERSTATE 25
 Between: _____ and _____
 Check if project was previously reviewed by: Sketch Plat/Plan or Pre-application Review Team(PRT) Review Date: 3-08-2017

SIGNATURE

(Print Name) MIKE BALASKOVITS

DATE 4/24/17

Applicant: Agent:

FOR OFFICIAL USE ONLY

<input type="checkbox"/> INTERNAL ROUTING	Application case numbers	Action	S.F.	Fees
<input type="checkbox"/> All checklists are complete	_____	_____	_____	\$ _____
<input type="checkbox"/> All fees have been collected	_____	_____	_____	\$ _____
<input type="checkbox"/> All case #s are assigned	_____	_____	_____	\$ _____
<input type="checkbox"/> AGIS copy has been sent	_____	_____	_____	\$ _____
<input type="checkbox"/> Case history #s are listed	_____	_____	_____	\$ _____
<input type="checkbox"/> Site is within 1000ft of a landfill	_____	_____	_____	\$ _____
<input type="checkbox"/> F.H.D.P. density bonus	_____	_____	_____	\$ _____
<input type="checkbox"/> F.H.D.P. fee rebate	_____	_____	_____	\$ _____
	Hearing date _____			Total \$ _____

Revised: 11/2014

Project # _____

Staff signature & Date _____

Bohannon Huston

Courtyard I
7500 Jefferson St. NE
Albuquerque, NM
87109-4335

www.bhinc.com

voice: 505.823.1000
facsimile: 505.798.7988
toll free: 800.877.5332

April 25, 2017

Mr. Jack Cloud, DRB Chair
City of Albuquerque
Planning Department
600 2nd Street NW
Albuquerque, NM 87103

Re: The Highlands – Final Plat DRB # 1010879

Dear Mr. Cloud:

Enclosed for Development Review Board (DRB) preliminary/final plat review and comment are copies of the following information:

- Development Review Application
- Form S(3)
- Certificate of No Effect
- Six (6) copies of the Final Plat
- Three (3) copies of Existing R/W Cross Sections
- Six (6) copies of Existing Site Sketch
- Zone Atlas Map

This preliminary/final plat is being presented to the Development Review Board for the purpose of obtaining City review and approval. The Highlands includes a total of 5 city blocks north of the Presbyterian Hospital currently subdivided. This plat proposes granting new easements necessary for the development, formally vacate right of way that has been approved at city council, dedicate right of way along Central, and subdivide the existing blocks into 6 new developable tracts.

It was determined at the Sketch Plat hearing (date 3/8/2017) that this submittal would not require an infrastructure list at this time. Infrastructure lists are anticipated as necessary for future Site Plan for Building Permit submittals as each site comes online.

Please schedule for the next appropriate DRB hearing. Please feel free to contact me at 823-1000 with questions or comments.

Sincerely,



Mike Balaskovits, PE
Senior Project Manager
Community Development and Planning

MJB/egn
Enclosures

Engineering ▲

Spatial Data ▲

Advanced Technologies ▲



City of Albuquerque
P.O. Box 1293 Albuquerque, NM 87103
Planning Department
Suzanne Lubar, Director

Richard J. Berry, Mayor
Robert J. Perry, CAO

DATE:

SUBJECT:

Case Number(s):

Agent:

Applicant:

Legal Description:

Zoning:

Acreage:

Zone Atlas Page(s):

CERTIFICATE OF NO EFFECT: **Yes** **No**

CERTIFICATE OF APPROVAL: **Yes** **No**

SUPPORTING DOCUMENTATION:

SITE VISIT:

RECOMMENDATIONS:

SUBMITTED BY:

SUBMITTED TO:

**PLAT OF
THE HIGHLANDS**
BLOCKS 3, 4, 5, 6, & 21
BROWNEWELL & LAIL'S HIGHLAND ADDITION
PROJECTED SECTION 21,
TOWNSHIP 10 NORTH, RANGE 3 EAST,
NEW MEXICO PRINCIPAL MERIDIAN
TOWN OF ALBUQUERQUE GRANT
ALBUQUERQUE, BERNALILLO COUNTY, NEW MEXICO
APRIL 2017

PROJECT NUMBER _____

APPLICATION NUMBER _____

UTILITY APPROVALS:

QWEST CORPORATION d/b/a CENTURYLINK QC _____ DATE _____

COMCAST CABLE _____ DATE _____

PNM ELECTRIC SERVICES _____ DATE _____

NEW MEXICO GAS COMPANY _____ DATE _____

CITY APPROVALS:

Soren M. Risenhoover P.S. 4/21/17
CITY SURVEYOR _____ DATE _____

TRAFFIC ENGINEERING, TRANSPORTATION DIVISION _____ DATE _____

ALBUQUERQUE BERNALILLO COUNTY
WATER UTILITY AUTHORITY _____ DATE _____

PARKS & RECREATION DEPARTMENT _____ DATE _____

A.M.A.F.C.A. _____ DATE _____

CITY ENGINEER _____ DATE _____

DRB CHAIRPERSON, PLANNING DEPARTMENT _____ DATE _____

REAL PROPERTY DIVISION _____ DATE _____

TAX CERTIFICATION

THIS IS TO CERTIFY THAT TAXES ARE CURRENT AND PAID ON UPC # _____

PROPERTY OWNER OF RECORD: _____

BERNALILLO COUNTY TREASURER'S OFFICE _____ DATE _____

SURVEYOR'S CERTIFICATION

I, Alan R. Benham, a registered Professional New Mexico Surveyor, certify that I am responsible for this survey and that this plat was prepared by me or under my supervision, shows all existing easements as shown on the plats of record, or made known to me by the owner, utility companies, or other interested parties and conforms to the Minimum Requirements of the Board of Registration for Professional Engineers and Professional Surveyors and meets the minimum requirements for monumentation and surveys contained in the Albuquerque Subdivision Ordinance, and is true and accurate to the best of my knowledge and belief.

Alan R. Benham
Alan R. Benham
New Mexico Professional Surveyor 15700

Date: *APRIL 21, 2017*

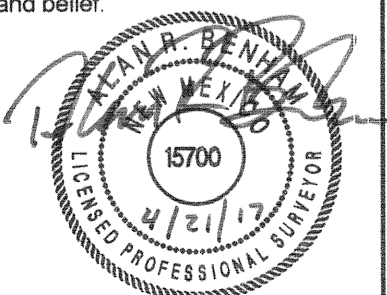

Bohannon & Huston
7500 JEFFERSON STREET NE ALBUQUERQUE, NEW MEXICO

DESCRIPTION

A certain tract of land located within the Town of Albuquerque Grant, projected Section 21, Township 10 North, Range 3 East, New Mexico Principal Meridian, City of Albuquerque, Bernalillo County, New Mexico, being and comprising a portion of Block 3, 4, 5, 6 and 21 of Brownwell & Lail's Highland Addition, as the same is shown and designated on the plat thereof, filed in the Office of the County Clerk of Bernalillo County, New Mexico on August 3, 1886 in Book B02, Page 032, and being more particularly described by New Mexico State Plane Grid Bearings (NAD83 Central Zone) and ground distances as follows:

BEGINNING at the southwest corner of the tract herein described and a point along the northerly right-of-way of East Central Ave, WHENCE the New Mexico State Highway Control Monument "1-25-27", a brass disc having New Mexico State Plane Grid Coordinates (NAD 83 Central Zone) N=1,484,404.486 and E=1,524,808.553, bears S 22°20'59" W a distance of 1295.73 feet;

THENCE along the westerly boundary of the tract herein described, the following two (2) courses:

N 09°09'00" E a distance of 129.01 feet;
N 80°51'00" W a distance of 166.00 feet to a point along the easterly right-of-way line of Oak Street;

THENCE continuing along the westerly boundary of the tract herein described, coincident with said easterly right-of-way line of Oak Street, N 09°09'00" E a distance of 142.00 feet to a point along the southerly right-of-way line of Copper Avenue NE and the northwest corner of the tract herein described;

THENCE along the northerly boundary of the tract herein described, coincident with said the southerly right-of-way line of Copper Avenue NE, S 80°51'00" E a distance of 375.79 feet to a point along the easterly right-of-way line of Mulberry Street NE;

THENCE continuing along the northerly boundary of the tract herein described, coincident with said easterly right-of-way line of Mulberry Street NE, the following two (2) courses:

N 09°17'12" E a distance of 60.06 feet;
N 09°07'15" E a distance of 300.00 feet to a point along the southerly right-of-way line of Tijeras Avenue;

THENCE continuing along the northerly boundary of the tract herein described, coincident with said the southerly right-of-way line of Tijeras Avenue NE, S 80°52'45" E a distance of 316.00 feet to a point along the westerly right-of-way line of Cedar Street NE;

THENCE continuing along the northerly boundary of the tract herein described, coincident with said westerly right-of-way line of Cedar Street NE, S 09°07'15" W a distance of 360.00 feet to a point along the southerly right-of-way line of Copper Avenue NE;

THENCE continuing along the northerly boundary of the tract herein described, coincident with said southerly right-of-way line of Copper Avenue NE, S 80°52'45" E a distance of 752.01 feet to a point along the westerly right-of-way line of Sycamore Street NE and the northeast corner of the tract herein described;

THENCE along the easterly boundary of the tract herein described, coincident with said westerly right-of-way line of Sycamore Street NE, S 09°08'23" W a distance of 300.00 feet to a point along said northerly right-of-way line of East Central Avenue and the southeast corner of the tract herein described;

THENCE along the southerly boundary of the tract herein described, the following twenty-six (26) courses:

N 80°52'45" W a distance of 149.96 feet;
N 78°40'30" W a distance of 15.96 feet;
S 09°07'15" E a distance of 0.61 feet;
N 80°52'45" W a distance of 150.07 feet;
N 09°07'15" E a distance of 6.47 feet;
N 80°22'08" W a distance of 60.05 feet;
S 09°07'15" E a distance of 7.00 feet;
N 80°52'45" W a distance of 149.77 feet;
N 09°07'15" E a distance of 21.68 feet;
N 80°21'56" W a distance of 16.16 feet;
S 09°07'15" E a distance of 21.83 feet;
N 80°52'28" W a distance of 94.54 feet;
39.30 feet along an arc of a curve to the right, having a radius of 87.88 feet, a central angle of 25°37'10" and a chord bearing N 53°07'48" W for a distance of 38.97 feet;
51.57 feet along an arc of a curve to the left, having a radius of 603.31 feet, a central angle of 4°53'51" and a chord bearing N 89°33'23" W for a distance of 51.55 feet;
N 79°07'17" W a distance of 30.01 feet;
N 80°51'06" W a distance of 38.70 feet;
41.91 feet along an arc of a curve to the right, having a radius of 83.76 feet, a central angle of 28°39'55" and a chord bearing S 83°26'21" W for a distance of 41.47 feet;
N 80°57'24" W a distance of 71.45 feet;
N 09°07'15" E a distance of 11.36 feet;
N 82°37'40" W a distance of 15.91 feet;
S 09°07'15" W a distance of 10.87 feet;
N 80°52'45" W a distance of 149.89 feet;
N 09°07'15" E a distance of 21.05 feet;
N 77°46'15" W a distance of 60.20 feet;
S 09°09'00" W a distance of 14.35 feet;
N 73°38'05" W a distance of 151.20 feet to the POINT OF BEGINNING.

The above described tract contains ± 11.7904 acres, more or less.

FREE CONSENT AND DEDICATION

The plat shown hereon is made with free consent and in accordance of the desires of the undersigned owner(s), the execution of this plat is their free act and deed. Those signing as owner(s) warrant that they hold among them, complete indefeasible title in fee simple to the land shown on this plat. Owner(s) hereby affirm that the described property shown on this plat lies within the platting and subdivision jurisdiction of Albuquerque, New Mexico. Said owner(s) hereby grant all Easements and dedicate public street right-of-way as may be shown on this plat in Fee Simple with Warranty Covenants.

Cedar Investors LLC, a New Mexico limited liability company

Name: *[Signature]*
Title: *MANAGER*

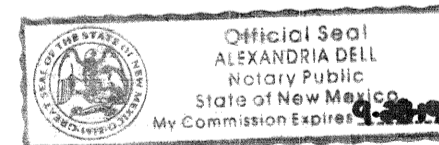

State of New Mexico)
 SS
County of Bernalillo)

This instrument was acknowledged before me on 21 day of April, 2017, by DAew Odan
Manager, Cedar Investors, LLC

My Commission Expires: 9-28-19 *Alexandria Dell*
Notary Public

NOTES

- Bearings are New Mexico State Plane Grid Bearings (Central Zone) NAD 1927. Basis of Bearings is between City of Albuquerque Control Monuments "4_K15" and "5_K18A". Bearing = S84°17'47"E 5634.13'
- Distances are ground distances.
- Record block dimensions are 316 ft by 316 ft including 16 ft alleys, as the same is shown in Brownwell & Lail's Highland Addition, filed on August 3, 1886 in Book B02, Page 032. Record bearings and distances are not shown in this plat.
- This Plat was prepared with information included in Title Commitment issued by Old Republic National Title Insurance Company, Commitment No. 1603902, Effective Date: April 3, 2017
- Property is located within Zone "X" as shown on FEMA Flood Insurance Rate Map No. 135001C0334G. Dated September 26, 2008.
- Pursuant to Section 14-14-4-7 of the City of Albuquerque Code of Ordinances, "No property within the area of this Plat shall at any time be subject to a deed restriction, covenant, or binding agreement prohibiting solar collectors from being installed on buildings or erected on the lots or parcels within the area of proposed Plat. The foregoing requirement shall be a condition to approval of this plat".

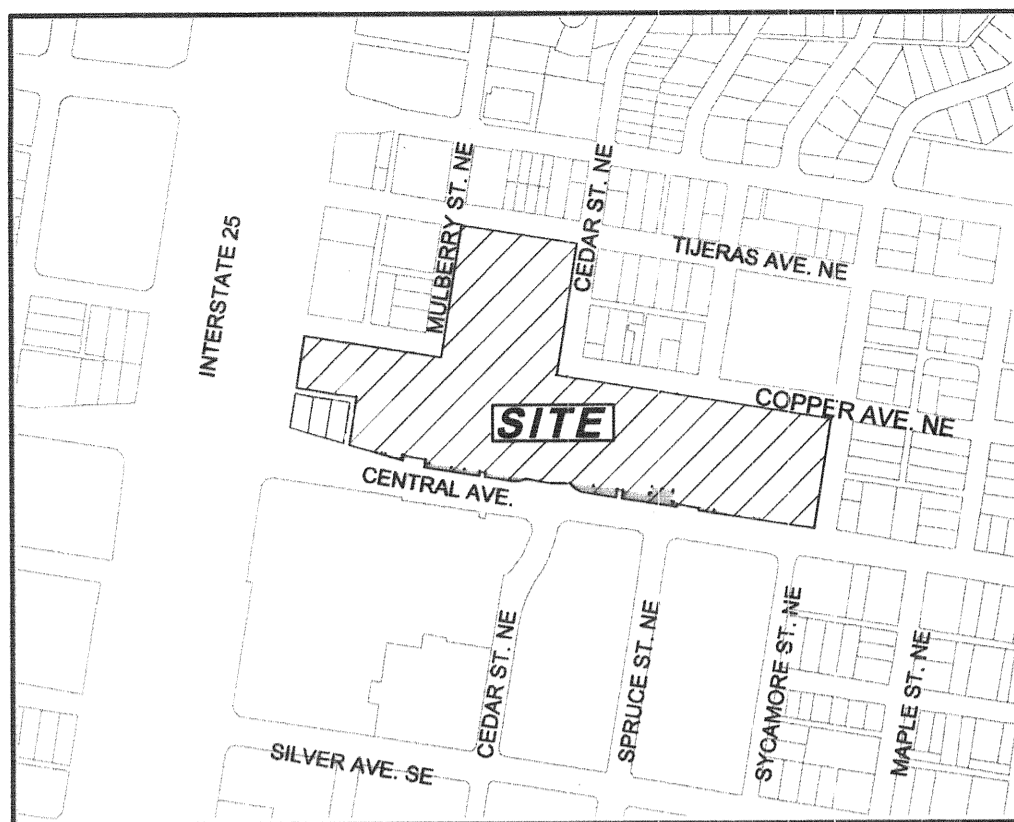

LOCATION MAP
NOT TO SCALE

SUBDIVISION DATA

- DRB No.
- Zone Atlas Index Number: K-15
- Gross Subdivision Acreage: 11.7904 Ac.
- Total number of Lots/Tracts Created: Six (6) Tracts.
- 0 miles public street right-of-way created.
- No private streets created.
- Area of private streets created: N/A.
- Date of Survey: March, 2016.
- Plat is located within Town of Albuquerque Grant, projected Sections 21, Township 10 North, Range 3 East, New Mexico Principal Meridian, City of Albuquerque, Bernalillo County, New Mexico.

PURPOSE OF PLAT

The purpose of this Plat is to Subdivide Blocks 3, 4, 5, 6 & 21 as the same are shown and designated on the Brownwell & Lail's Highland Addition Plat filed August 3, 1886, in Book B02, Page 032, to vacate and dedicate public rights-of-way and to vacate public and private easement as may be shown herein.

PUBLIC UTILITY EASEMENTS

PUBLIC UTILITY EASEMENTS shown on this plat are granted for the common and joint use of:

- Public Service Company of New Mexico ("PNM"), a New Mexico corporation, (PNM Electric) for installation, maintenance, and service of overhead and underground electrical lines, transformers, and other equipment and related facilities reasonably necessary to provide electrical services.
- New Mexico Gas Company for installation, maintenance, and service of natural gas lines, valves and other equipment and facilities reasonably necessary to provide natural gas.
- Qwest Corporation d/b/a CenturyLink QC for the installation, maintenance, and service of such lines, cable, and other related equipment and facilities reasonably necessary to provide communication services.
- Cable TV for the installation, maintenance, and service of such lines, cable, and other related equipment and facilities reasonably necessary to provide Cable services.

Included, is the right to build, rebuild, construct, reconstruct, locate, relocate, change, remove, replace, modify, renew, operate and maintain facilities for purposes described above, together with free access to, from, and over said easements, with the right and privilege of going upon, over and across adjoining lands of Grantor for the purposes set forth herein and with the right to utilize the right of way and easement to extend services to customers of Grantee, including sufficient working area space for electric transformers, with the right and privilege to trim and remove trees, shrubs or bushes which interfere with the purposes set forth herein. No building, sign, pool (above ground or subsurface), hot tub, concrete or wood pool decking, or other structure shall be erected or constructed on said easements, nor shall any well be drilled or operated thereon. Property owners shall be solely responsible for correcting any violations of National Electrical Safety Code by construction of pools, decking, or any structures adjacent to or near easements shown on this plat.

Easements for electric transformer/switchgears, as installed, shall extend ten (10) feet in front of transformer/switchgear doors and five (5) feet on each side.

Disclaimer

In approving this plat, Public Service Company of New Mexico (PNM), New Mexico Gas Company (NMGC) and Qwest Corporation D/B/A CenturyLink (QWEST) did not conduct a Title Search of the properties shown hereon. Consequently, PNM, NMGC and QWEST do not waive or release any easement or easement rights which may have been granted by prior plat, replat or other document and which are not shown on this plat.

**PLAT OF
THE HIGHLANDS**
BLOCKS 3, 4, 5, 6, & 21
BROWNEWELL & LAIL'S HIGHLAND ADDITION
PROJECTED SECTION 21,
TOWNSHIP 10 NORTH, RANGE 3 EAST,
NEW MEXICO PRINCIPAL MERIDIAN
TOWN OF ALBUQUERQUE GRANT
ALBUQUERQUE, BERNALILLO COUNTY, NEW MEXICO
APRIL 2017

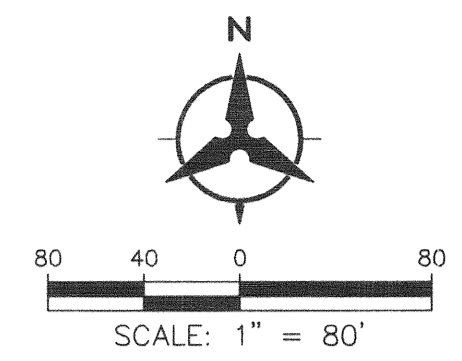

LEGEND	
	CITY OF ALBUQUERQUE CONTROL
	FOUND IRON PIPE
	FOUND IRON REBAR WITH NO CAP
	FOUND REBAR WITH CAP STAMPED "PS 10464" UNLESS OTHERWISE NOTED
	FOUND NAIL AND WASHER STAMPED "PS 10464"
	FOUND CHISELED MARK IN CONCRETE
	SET REBAR W/ PLASTIC CAP STAMPED "BENHAM 15700"
	BOUNDARY LINE
	NEW EASEMENT LINE
	LOT LINE TO BE ELIMINATED WITH THE FILING OF THIS PLAT
	ADJOINING PROPERTY LINE
	EXISTING EASEMENT LINE
	PUBLIC ACCESS OR PUBLIC ALLEY VACATED WITH THE FILING OF THIS PLAT 16DRB-70447
	RIGHT-OF-WAY DEDICATED WITH THE FILING OF THIS PLAT

Curve Data							
ID	DELTA	TANGENT	ARC	RADIUS	CHORD	CHORD BRG	DEG OF CRV
C1	25°37'10" RT	19.98'	39.30'	87.88'	38.97'	N53°07'48"W	65°11'52"
C2	04°53'51" LT	25.80'	51.57'	603.31'	51.55'	N88°33'23"W	09°29'49"
C3	28°39'55" RT	21.40'	41.91'	83.76'	41.47'	S83°26'21"W	88°24'17"
C4	11°01'19" LT	58.21'	116.06'	603.31'	115.88'	N86°29'39"W	09°29'49"
C5	06°07'29" RT	32.28'	64.49'	603.31'	64.46'	S84°02'43"E	09°29'49"

Tangent Data		
ID	BEARING	DISTANCE
T1	N09°17'12"E	60.06'
T2	N78°40'30"W	15.96'
T3	S09°07'15"W	0.61'
T4	N09°07'15"E	6.47'
T5	N80°22'08"W	60.06'
T6	S09°07'15"W	7.00'
T7	N09°07'15"E	21.68'
T8	N80°21'56"W	16.16'
T9	S09°07'15"W	21.83'
T10	N79°07'17"W	30.01'
T11	N80°51'06"W	38.70'
T12	N09°07'15"E	11.36'
T13	N82°37'40"W	15.91'
T14	S09°07'15"W	10.87'
T15	N09°07'15"E	21.06'
T16	N77°46'15"W	60.20'
T17	S09°09'00"W	14.35'
T18	S09°19'42"W	29.98'
T19	N80°36'34"W	2.38'
T20	S09°28'47"W	5.64'

Tangent Data		
ID	BEARING	DISTANCE
T21	N80°53'42"W	46.37'
T22	S10°15'26"W	2.00'
T23	N79°44'34"W	10.00'
T24	N79°44'10"W	13.36'
T25	N80°21'15"W	34.84'
T26	N80°06'01"W	61.61'
T27	S10°02'07"W	0.50'
T28	N79°25'43"W	10.93'
T29	S10°06'41"W	7.84'
T30	N79°44'33"W	1.19'
T31	S09°14'43"W	30.08'
T32	N80°21'15"W	41.57'
T33	S09°07'15"W	30.02'
T34	N80°52'45"W	29.97'
T35	N80°53'00"W	28.04'
T36	S08°38'37"W	16.31'
T37	N80°50'48"W	4.65'
T38	S09°09'14"W	4.58'
T39	N80°50'46"W	39.37'
T40	N76°06'08"W	69.76'

Tangent Data		
ID	BEARING	DISTANCE
T41	N80°50'46"W	41.18'
T42	N80°50'46"W	10.02'
T43	S09°07'15"W	5.87'
T44	N80°50'46"W	5.87'
T45	S09°09'09"W	25.83'
T46	N80°50'51"W	0.50'
T47	S09°05'07"W	4.29'
T48	N80°53'00"W	29.85'
T49	N73°38'05"W	72.72'
T50	S80°21'15"E	76.41'
T51	S80°53'00"E	57.89'

- A** LOTS G-J, BLK 21, BROWNEWELL & LAIL'S HIGHLAND ADDITION FILED: NOVEMBER 3, 1924 (BOOK A01 - PAGE 087)
- B** WHITTEDS REPLAT FILED: JUNE 2, 1924
- C** LOT 4-A, BLK 3, BROWNEWELL AND LAIL'S HIGHLAND ADDITION FILED: AUGUST 9, 1993 (BOOK 89C - PAGE 230)
- D** LOTS 11-A AND 12-A, BLK 4; LOTS 7-A AND 8-A, BLK 6, BROWNEWELL AND LAIL'S HIGHLAND ADDITION FILED: MARCH 1998 (BOOK 89C - PAGE 302)
- E** LOTS A-1 & A-2, BLK 6, BROWNEWELL AND LAIL'S HIGHLAND ADDITION FILED: NOVEMBER 23, 1982 (BOOK C20 - PAGE 97)

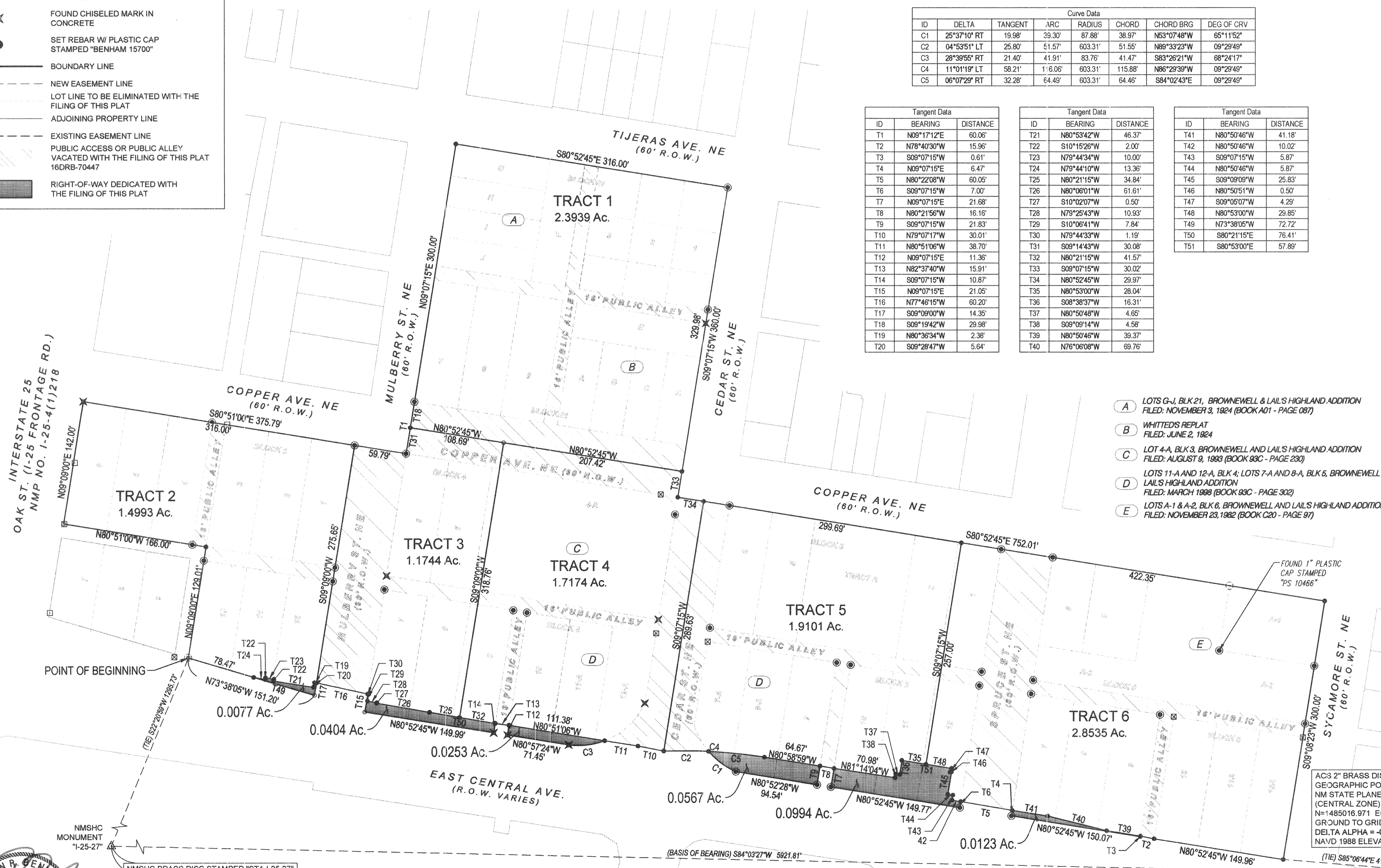

NMSHC BRASS DISC STAMPED "STA I-25-27"
GEOGRAPHIC POSITION (NAD 1983)
NM STATE PLANE GRID COORDINATES
(CENTRAL ZONE)
N=1484404.489 E=1524608.553
GROUND TO GRID FACTOR=0.99967636
DELTA ALPHA = -0°13'20.86"
NAVD 1988 ELEVATION = 5000.315 FEET

ACS 2" BRASS DISC "5-K16A"
GEOGRAPHIC POSITION (NAD 1983)
NM STATE PLANE GRID COORDINATES
(CENTRAL ZONE)
N=1485016.971 E=1530495.993
GROUND TO GRID FACTOR=0.999670253
DELTA ALPHA = -0°12'40.20"
NAVD 1988 ELEVATION = 5174.054 FEET

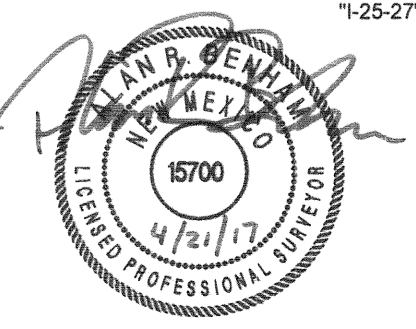

**PLAT OF
THE HIGHLANDS**
BLOCKS 3, 4, 5, 6, & 21
BROWNEWELL & LAIL'S HIGHLAND ADDITION
PROJECTED SECTION 21,
TOWNSHIP 10 NORTH, RANGE 3 EAST,
NEW MEXICO PRINCIPAL MERIDIAN
TOWN OF ALBUQUERQUE GRANT
ALBUQUERQUE, BERNALILLO COUNTY, NEW MEXICO
APRIL 2017

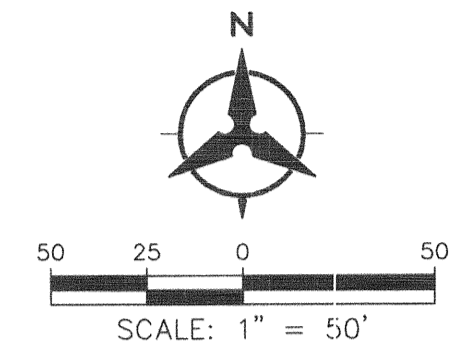

CURVE DATA						
ID	DELTA	TANGENT	ARC	RADIUS	CHORD	CHORD BRG
C6	00°05'48" LT	0.51'	1.02'	603.33'	1.02'	S88°02'36"W

TANGENT DATA		
ID	BEARING	DISTANCE
T52	N80°51'00"W	19.55'
T53	N77°46'15"W	28.54'
T54	N09°09'00"E	20.00'
T55	S80°51'00"E	20.00'
T56	S80°51'00"E	28.12'
T57	S08°37'21"W	20.00'
T58	S80°52'45"E	39.00'
T59	N80°52'45"W	19.00'
T60	N79°07'17"W	19.01'
T61	N77°46'15"W	19.64'



LEGEND	
	CITY OF ALBUQUERQUE CONTROL
	FOUND IRON PIPE
	FOUND IRON REBAR WITH NO CAP
	FOUND REBAR WITH CAP STAMPED "PS 10464" UNLESS OTHERWISE NOTED
	FOUND NAIL AND WASHER STAMPED "PS 10464"
	FOUND CHISELED MARK IN CONCRETE
	SET REBAR W/ PLASTIC CAP STAMPED "BENHAM 15700"
	BOUNDARY LINE
	NEW EASEMENT LINE
	LOT LINE TO BE ELIMINATED WITH THE FILING OF THIS PLAT
	ADJOINING PROPERTY LINE
	EXISTING EASEMENT LINE
	ABCWUA EASEMENT GRANTED WITH THE FILING OF THIS PLAT
	ACCESS EASEMENT GRANTED WITH THE FILING OF THIS PLAT
	RIGHT-OF-WAY DEDICATED WITH THE FILING OF THIS PLAT

NMESH BRASS DISC STAMPED "STA I-25-27"
GEOGRAPHIC POSITION (NAD 1983)
NM STATE PLANE GRID COORDINATES
(CENTRAL ZONE)
N=1484404.489 E=1524608.553
GROUND TO GRID FACTOR=0.999676736
DELTA ALPHA = -0°13'20.86"
NAVD 1988 ELEVATION = 5000.315 FEET

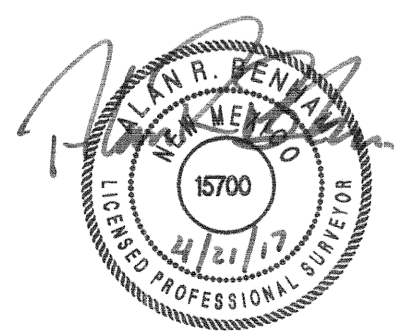

Bohannon & Huston
7500 JEFFERSON STREET NE ALBUQUERQUE, NEW MEXICO

\\20160155\SURVEY\GRAPHICS\20160155_PLAT.dwg
Fri, 21-Apr-2017 - 11:36:am, Plotted by: AWANG

**PLAT OF
THE HIGHLANDS**
BLOCKS 3, 4, 5, 6, & 21
BROWNEWELL & LAIL'S HIGHLAND ADDITION
PROJECTED SECTION 21,
TOWNSHIP 10 NORTH, RANGE 3 EAST,
NEW MEXICO PRINCIPAL MERIDIAN
TOWN OF ALBUQUERQUE GRANT
ALBUQUERQUE, BERNALILLO COUNTY, NEW MEXICO
APRIL 2017

LEGEND	
	CITY OF ALBUQUERQUE CONTROL
	FOUND IRON PIPE
	FOUND IRON REBAR WITH NO CAP
	FOUND REBAR WITH CAP STAMPED "PS 10464" UNLESS OTHERWISE NOTED
	FOUND NAIL AND WASHER STAMPED "PS 10464"
	FOUND CHISELED MARK IN CONCRETE
	SET REBAR W/ PLASTIC CAP STAMPED "BENHAM 15700"
	BOUNDARY LINE
	NEW EASEMENT LINE
	LOT LINE TO BE ELIMINATED WITH THE FILING OF THIS PLAT
	ADJOINING PROPERTY LINE
	EXISTING EASEMENT LINE
	ABCWUA EASEMENT GRANTED WITH THE FILING OF THIS PLAT
	ACCESS EASEMENT GRANTED WITH THE FILING OF THIS PLAT
	RIGHT-OF-WAY DEDICATED WITH THE FILING OF THIS PLAT

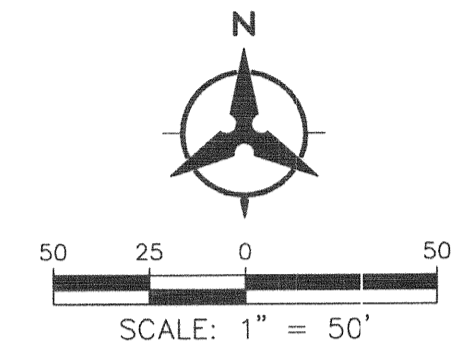

ACS 2" BRASS DISC "5-K16A"
GEOGRAPHIC POSITION (NAD 1983)
NM STATE PLANE GRID COORDINATES
(CENTRAL ZONE)
N=1485016.971 E=1530495.993
GROUND TO GRID FACTOR=0.999670253
DELTA ALPHA = -0°12'40.20"
NAVD 1988 ELEVATION = 5174.054 FEET

ACS
MONUMENT
"5_K16A"



Bohannon & Huston
7500 JEFFERSON STREET NE ALBUQUERQUE, NEW MEXICO

P:\2017\1015\SURVEY\GHA\PLAT\052017\03_05_P1A1.dwg
Plotted: 21-Apr-2017 11:38:00 AM, Plotted by: AMANG

P:\20160155\01\Design\Workarea\Plot Sections.dwg
April 24, 2017 - 1:40pm
Overall

Bohannon  **Huston**

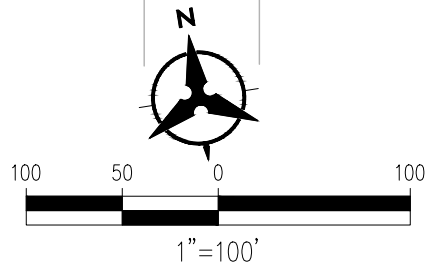
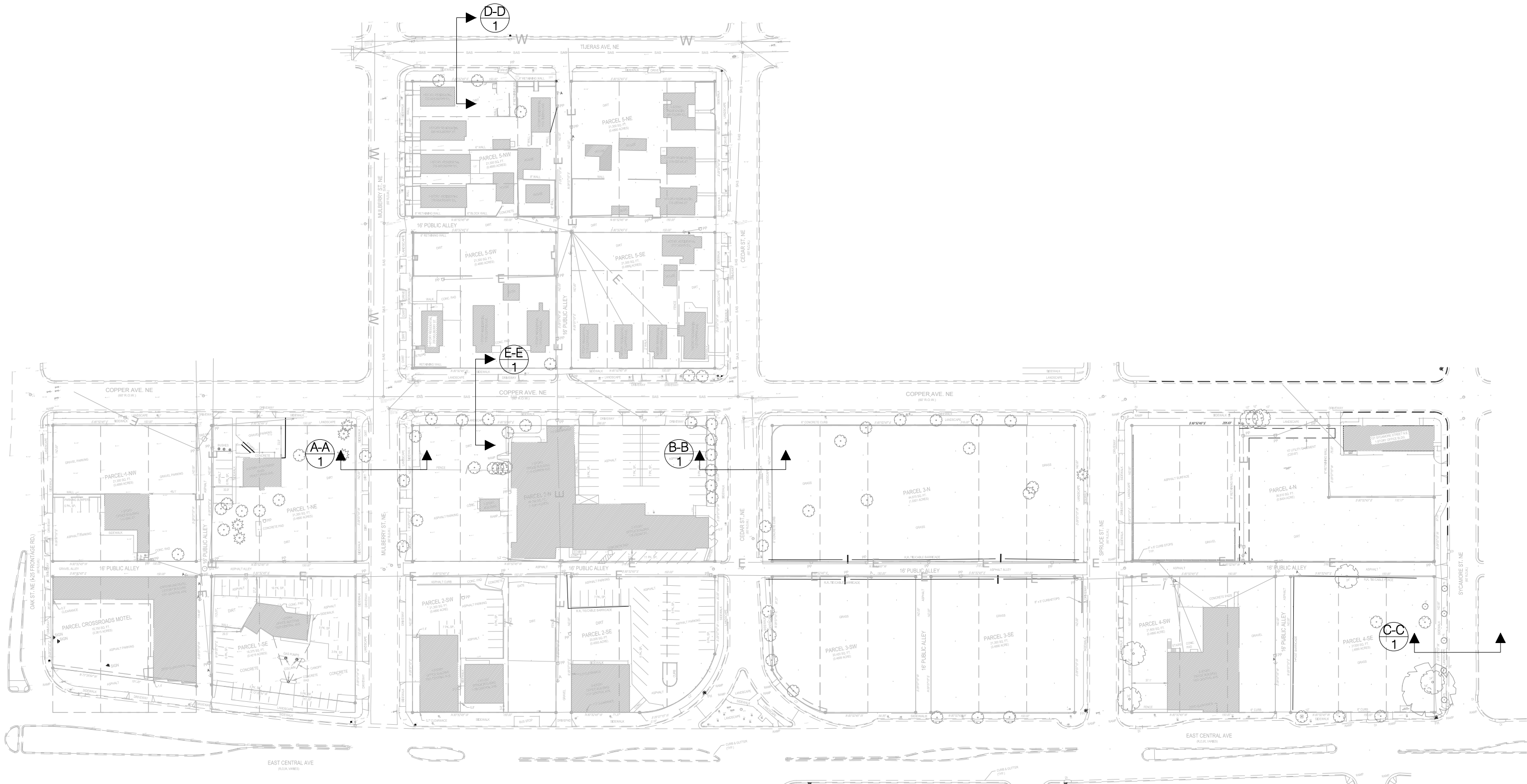

THE HIGHLANDS			
EXISTING STREET SECTIONS			
DRAWN BY:	EGN	DATE:	04/25/2017
CHECKED BY:	MJB	PROJECT NO.	20160155
		SHEET NO.	1 of 2

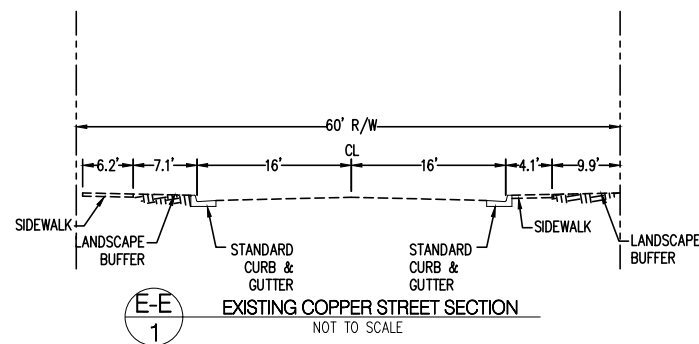
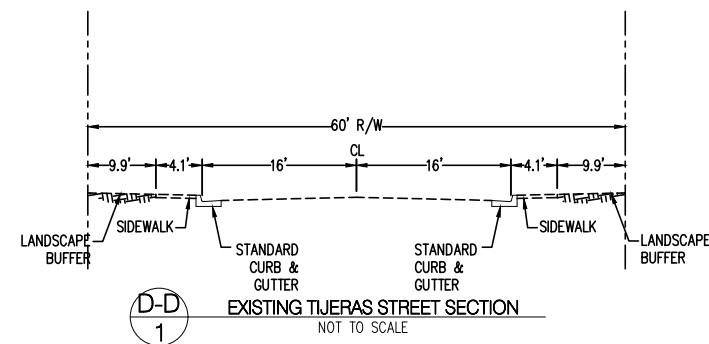
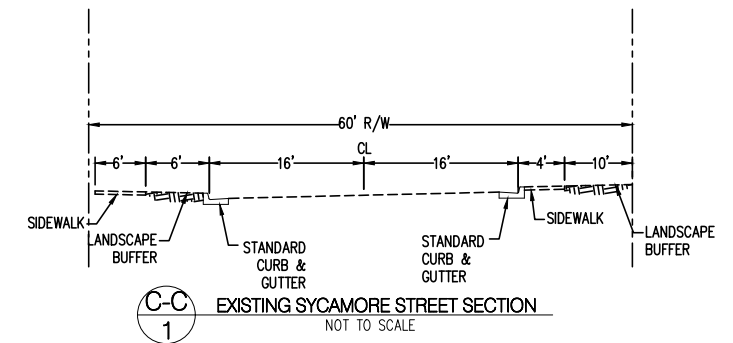
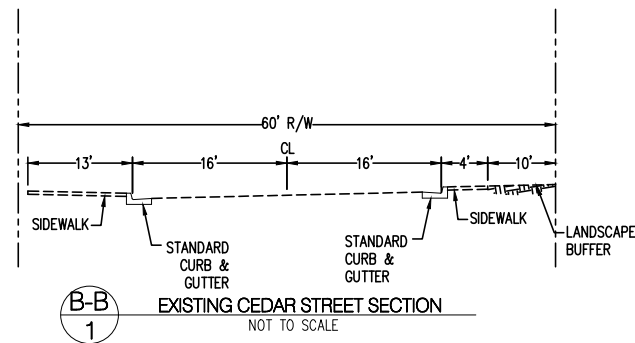
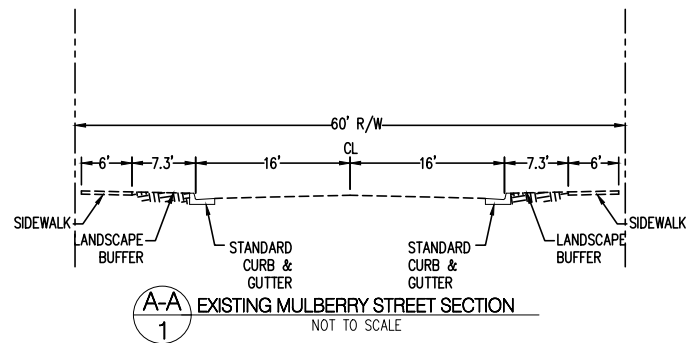

NOTE: EXISTING SECTIONS FROM CENTRAL AVE. HAVE BEEN INCLUDED FROM THE ART PROJECT (CPN #631991) STAMPED 06/17/16 ALONG THE FRONTAGE OF THIS DEVELOPMENT.

THE HIGHLANDS

EXISTING STREET SECTIONS

DRAWN BY:	EGN	DATE:	04/25/2017
CHECKED BY:	MJB	PROJECT NO.	20160155
		SHEET NO.	2 of 2

Date: 15 Jun 2016 10:15pm User: zahorp Layout: 0601
Drawing Name: 0601.dwg



HR
2155 LOUISIANA BLVD NE, SUITE 9500
ALBUQUERQUE, NM 87110
MAIN: (505) 830-5400
FAX: (505) 830-5454

ABC RIDE		CITY OF ALBUQUERQUE TRANSIT DEPARTMENT ABQ RIDE	
TITLE: CENTRAL AVENUE ALBUQUERQUE RAPID TRANSIT OVERALL SEGMENT PLAN			
Design Review Committee APPROVED JUL 19 2016 DESIGN REVIEW COMMITTEE	City Engineer Approval APPROVED JUL 19 2016 CITY ENGINEER	Mo./Day/Yr.	Mo./Day/Yr.
CITY PROJECT NO. 631991	ZONE MAP NO. K15-K17	SEGMENT NO. S4	SHEET 3 OF 447

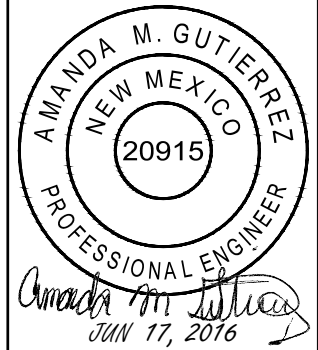

NO.	DATE	REMARKS	BY
		REVISIONS	
		DESIGN	
	DESIGNED BY: XX		DATE: 06/2016
	DRAWN BY: XX		DATE: 06/2016
	CHECKED BY: XX		DATE: 06/2016

SURVEY INFORMATION	
FIELD NOTES	NO.
BY	

BENCHMARKS	
PROJECT PRIMARY BENCHMARK:	5_K16A
A CITY OF ALBUQUERQUE 2 INCH BRASS DISC SET FLUSH IN THE SIDEWALK AND STAMPED "5-K16A". THE MONUMENT IS LOCATED ON THE NORTH SIDE OF CENTRAL AVE BETWEEN STANFORD DR AND COLUMBIA DR SE.	
NM SPC CENTRAL ZONE GRID:	
N: 1485016.971 USFT	
E: 1530495.993 USFT	
ELEV: 5174.054	

AS BUILT INFORMATION	
CONTRACTOR	DATE
INSPECTOR'S	DATE:
ACCEPTANCE BY	DATE:
FIELD	DATE:
DRAWINGS	DATE:
CORRECTED BY	DATE:
MICRO-FILM INFORMATION	
RECORDED BY	DATE:
NO.	

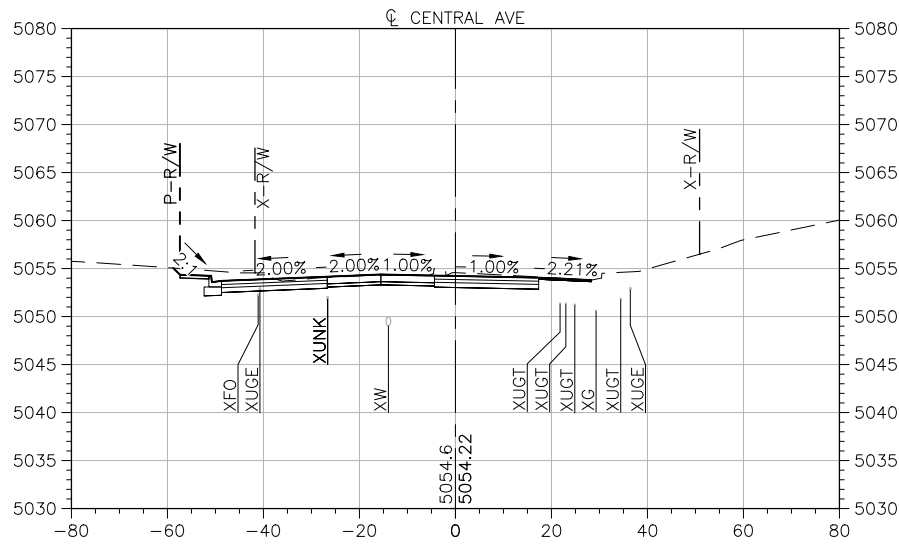

405+00.00

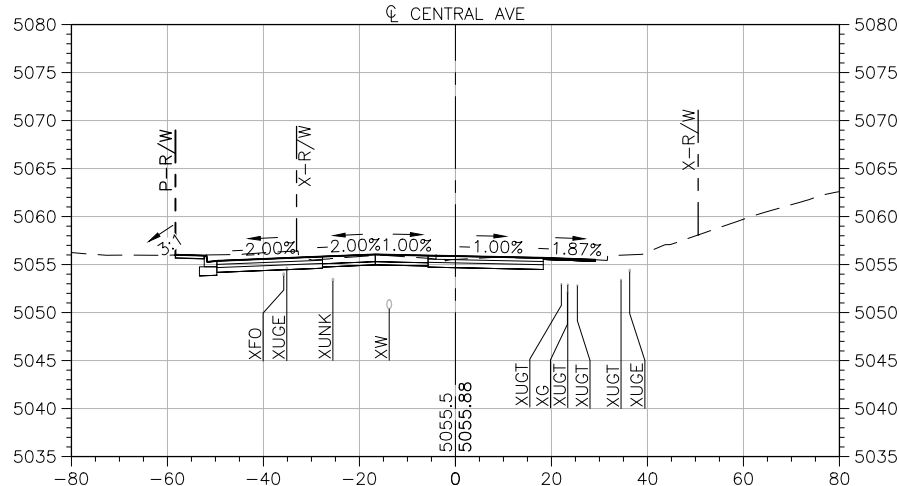

405+50.00

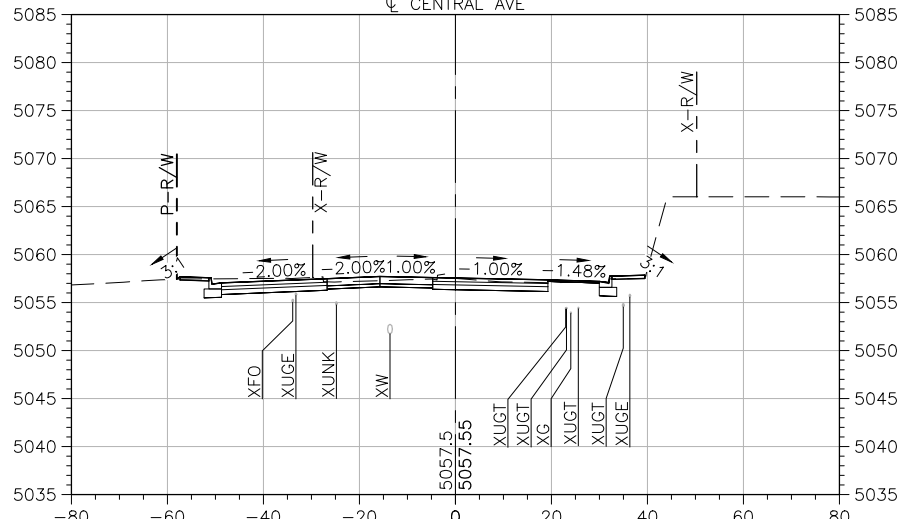

406+00.00

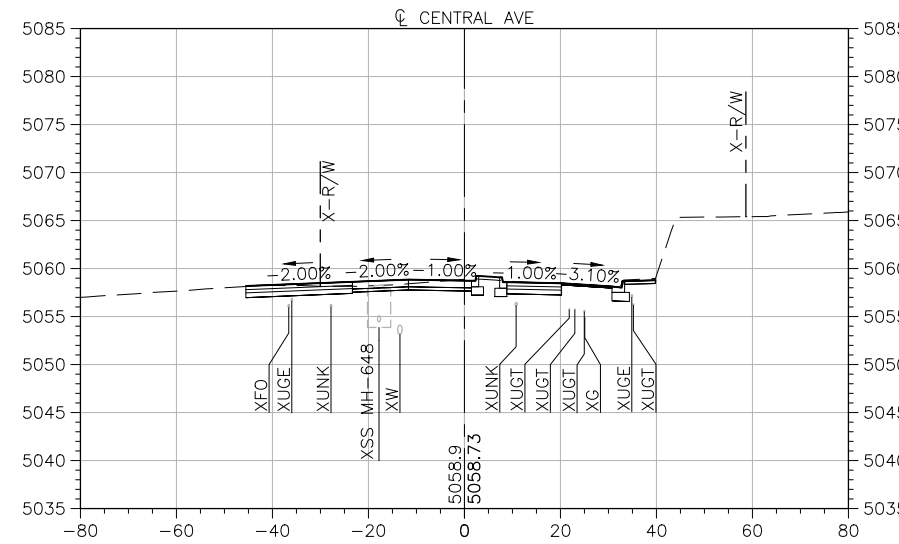

406+50.00

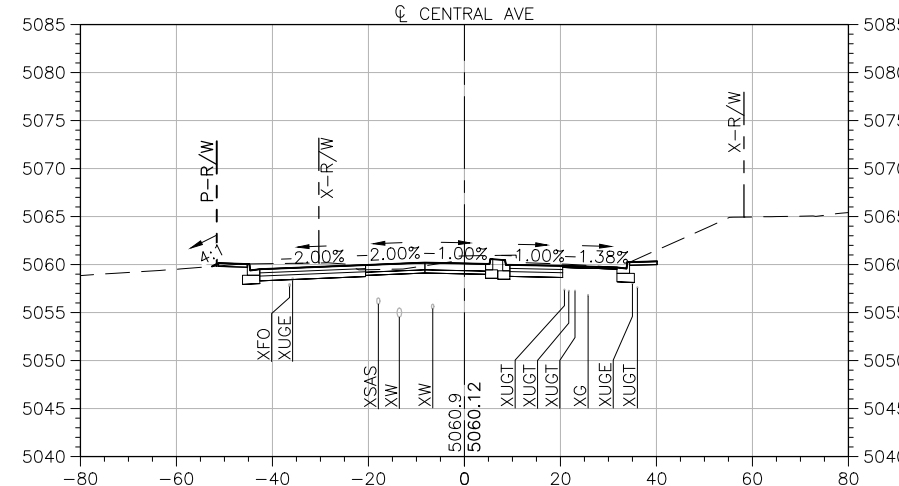

407+00.00

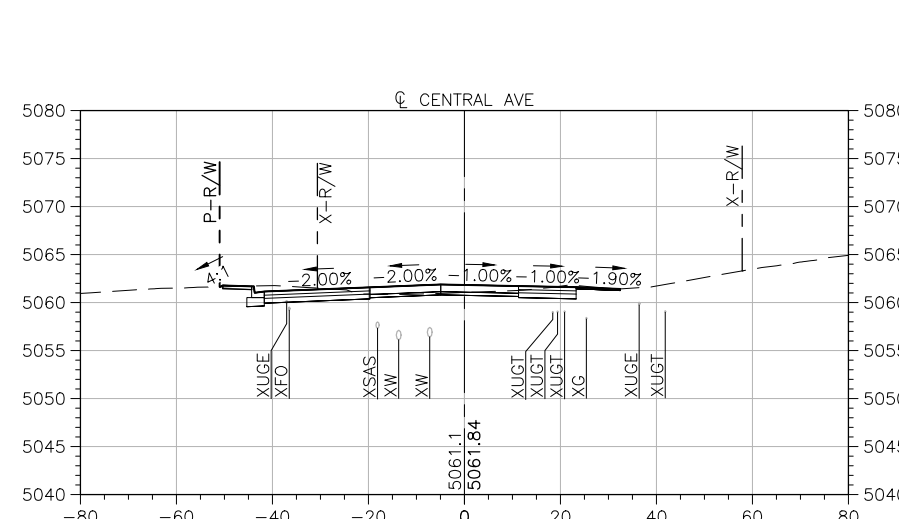

407+50.00

LEGEND	
	EXISTING GROUND
	FINISHED GRADE
	COA STANDARD CURB & GUTTER & SIDEWALK
	COA MEDIAN CURB & GUTTER & LANDSCAPE OR MEDIAN PAVEMENT
	ART PAVEMENT SECTION
	MILL & OVERLAY
	ASPHALT CONCRETE PAVEMENT SECTION
	ART STATION
	(PRS EASE) PRESCRIPTIVE USE EASEMENT
	(P-R/W) PROPOSED RIGHT OF WAY
	(X-R/W) EXISTING RIGHT OF WAY

BENCHMARKS	
PROJECT PRIMARY BENCHMARK: 5-K16A	CONTRACTOR
A CITY OF ALBUQUERQUE 2 INCH BRASS DISC SET FLUSH IN THE SIDEWALK AND STAMPED "5-K16A".	DATE:
THE MONUMENT IS LOCATED ON THE NORTH SIDE OF CENTRAL AVE BETWEEN STANFORD DR AND COLUMBIA DR SE.	INSPECTOR'S ACCEPTANCE BY DATE:
STANFORD DR AND COLUMBIA DR SE.	FIELD VERIFICATION BY DATE:
NM SPC CENTRAL ZONE GRID:	DRAWINGS CORRECTED BY DATE:
N: 1485016.971 USFT	RECORDED BY DATE:
E: 1530495.993 USFT	NO.
ELEV: 5174.054	

SURVEY INFORMATION	
FIELD NOTES	BY
NO.	

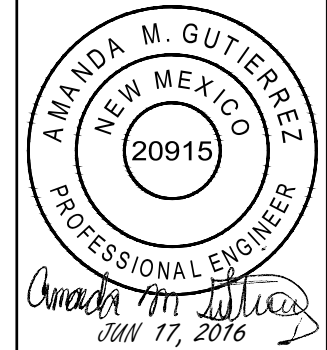

NO.	DATE	REMARKS	BY
		REVISIONS	
		DESIGN	

DESIGNED BY: AMG/ZAS	DATE: 06/2016
DRAWN BY: AMG/ZAS	DATE: 06/2016
CHECKED BY: ELP	DATE: 06/2016



2155 LOUISIANA BLVD NE, SUITE 9500
ALBUQUERQUE, NM 87110
MAIN: (505) 830-5400
FAX: (505) 830-5454

CITY OF ALBUQUERQUE TRANSIT DEPARTMENT ABQ RIDE	
TITLE:	CENTRAL AVENUE ALBUQUERQUE RAPID TRANSIT ROADWAY CROSS SECTIONS
Last Design Update	Mo./Day/Yr. Mo./Day/Yr.

CITY PROJECT NO. 631991	ZONE MAP NO. K15-K17	SEGMENT NO. S4	SHEET 3	OF 49
----------------------------	-------------------------	-------------------	------------	----------

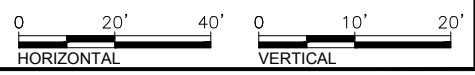

Date: 14 Jun 2016 11:53pm User: ZSW/EP Layout: C502 Drawing Name: C501.dwg

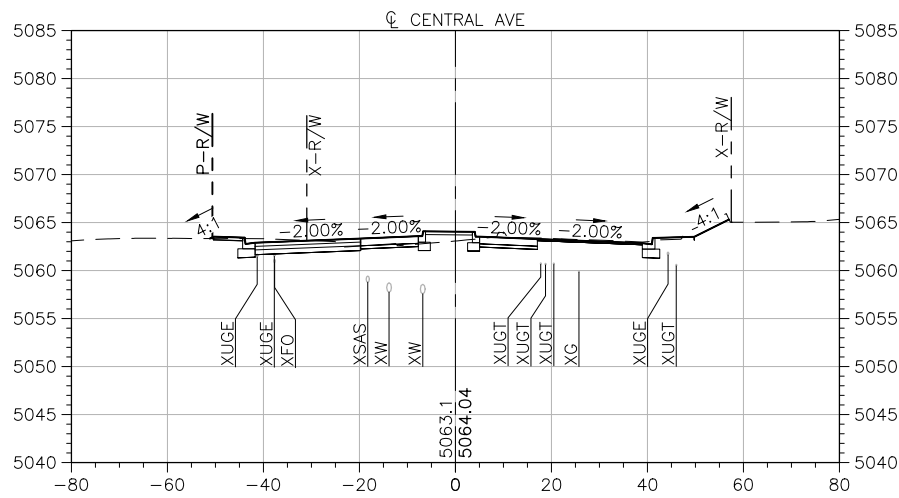

408+00.00

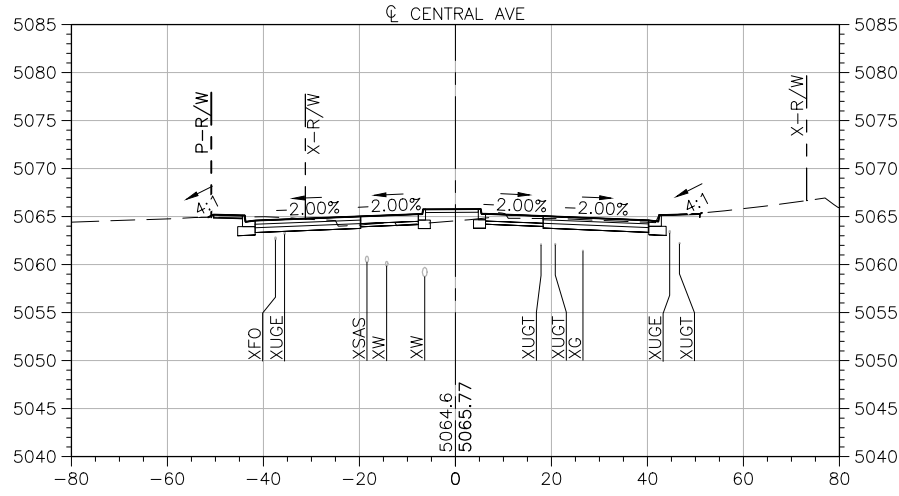

408+50.00

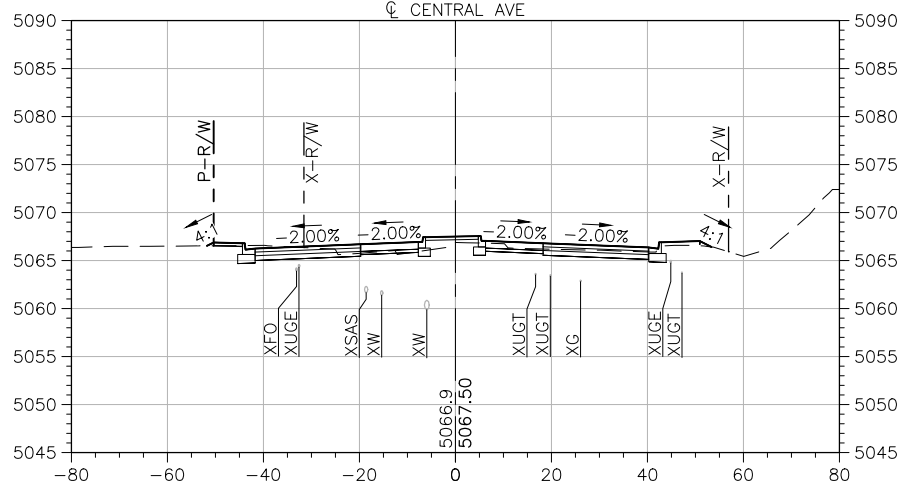

409+00.00

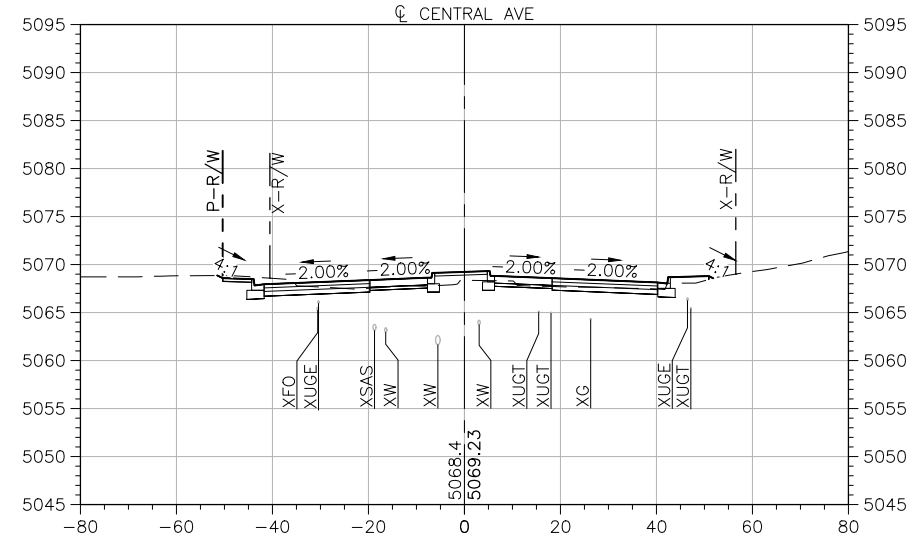

409+50.00

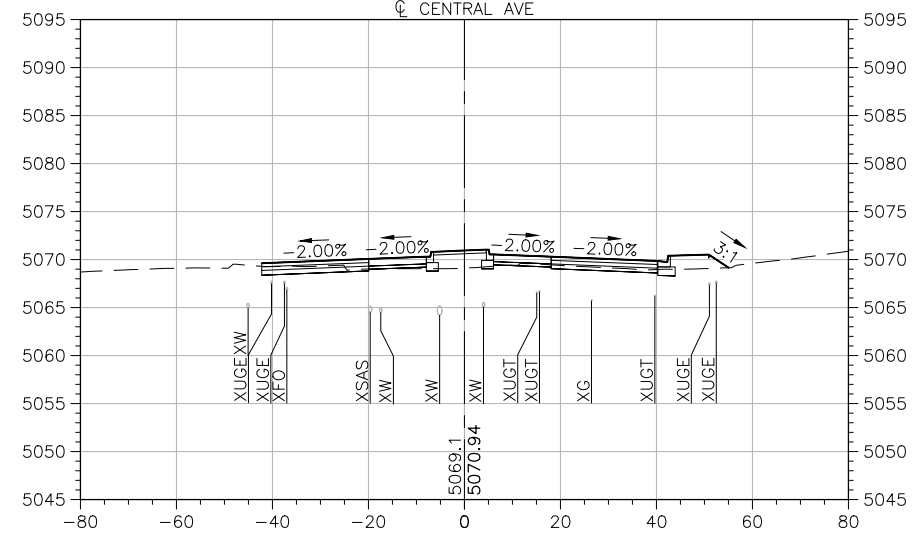

410+00.00

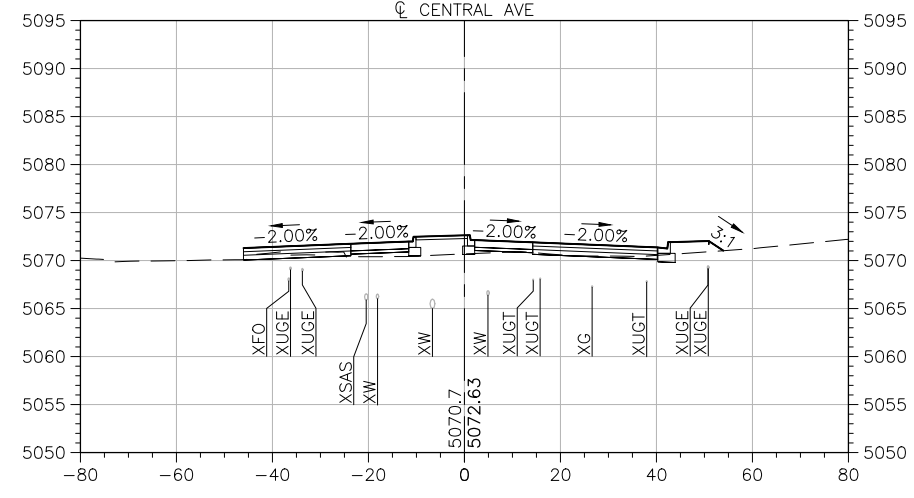

410+50.00

LEGEND

- EXISTING GROUND
- FINISHED GRADE
- COA STANDARD CURB & GUTTER & SIDEWALK
- COA MEDIAN CURB & GUTTER & LANDSCAPE OR MEDIAN PAVEMENT
- ART PAVEMENT SECTION
- MILL & OVERLAY
- ASPHALT CONCRETE PAVEMENT SECTION
- ART STATION

PRIS EASE

- P-R/W (PRIS EASE) PRESCRIPTIVE USE EASEMENT
- X-R/W (P-R/W) PROPOSED RIGHT OF WAY
- X-R/W (X-R/W) EXISTING RIGHT OF WAY

BENCHMARKS		AS BUILT INFORMATION	
PROJECT PRIMARY BENCHMARK: 5-K16A	CONTRACTOR	DATE:	DATE:
A CITY OF ALBUQUERQUE 2 INCH	INSPECTOR'S	DATE:	DATE:
BRASS DISC SET FLUSH IN THE	ACCEPTANCE BY	DATE:	DATE:
SIDEWALK AND STAMPED "5-K16A"	FIELD	DATE:	DATE:
THE MONUMENT IS LOCATED ON THE	DRAWINGS	DATE:	DATE:
NORTH SIDE OF CENTRAL AVE BETWEEN	CORRECTED BY	DATE:	DATE:
STANFORD DR AND COLUMBIA DR SE.	MICRO-FILM INFORMATION	RECORDED BY	DATE:
NM SPC CENTRAL ZONE GRID:		NO.	
N: 1485016.971 USFT			
E: 1530495.993 USFT			
ELEV: 5174.054			

SURVEY INFORMATION	
FIELD NOTES	BY
NO.	

AMANDA M. GUTIERREZ
NEW MEXICO
20915
PROFESSIONAL ENGINEER

Amanda M. Gutierrez
JUN 17, 2016

NO.	DATE	REMARKS	BY
		REVISIONS	
		DESIGN	

DESIGNED BY: AMG/ZAS DATE: 06/2016
DRAWN BY: AMG/ZAS DATE: 06/2016
CHECKED BY: ELP DATE: 06/2016

HR 2155 LOUISIANA BLVD NE, SUITE 9500
ALBUQUERQUE, NM 87110
MAIN: (505) 830-5400
FAX: (505) 830-6454

ABC RIDE CITY OF ALBUQUERQUE TRANSIT DEPARTMENT ABQ RIDE

TITLE: CENTRAL AVENUE ALBUQUERQUE RAPID TRANSIT ROADWAY CROSS SECTIONS

Last Design Update	
Mo./Day/Yr.	Mo./Day/Yr.

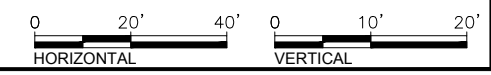

Date: 14 Jun 2016 11:54am User: ZSW/EP Layout: C503 Drawing Name: C501.dwg

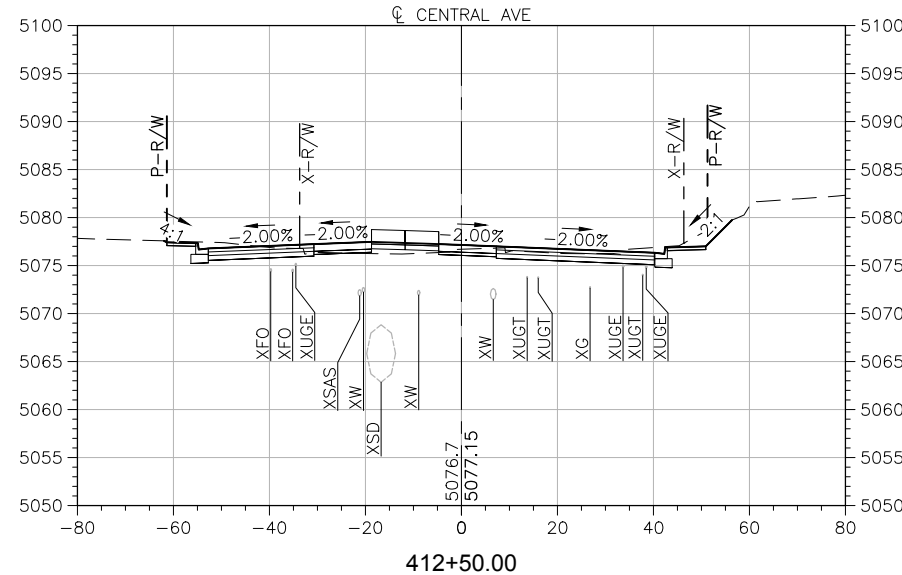
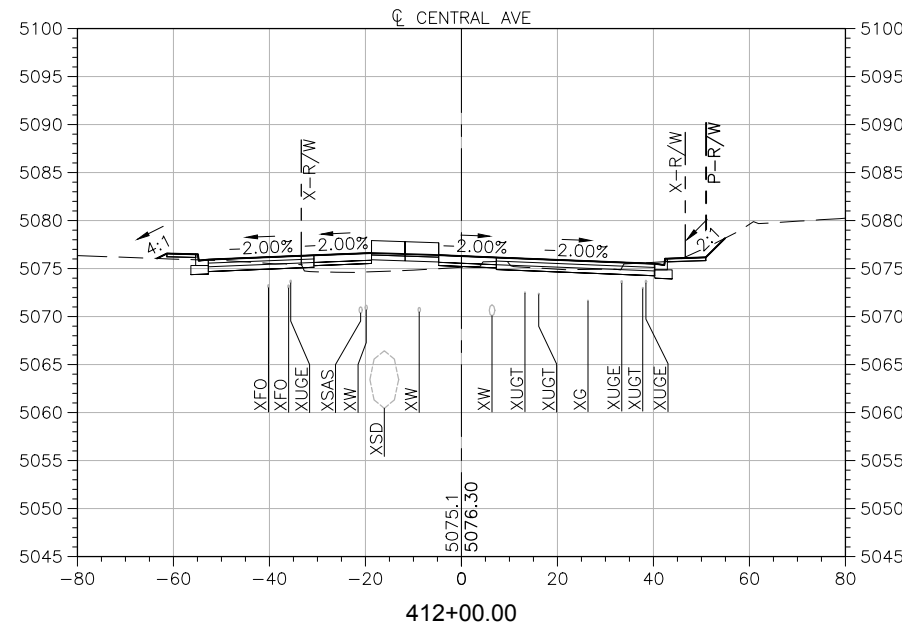
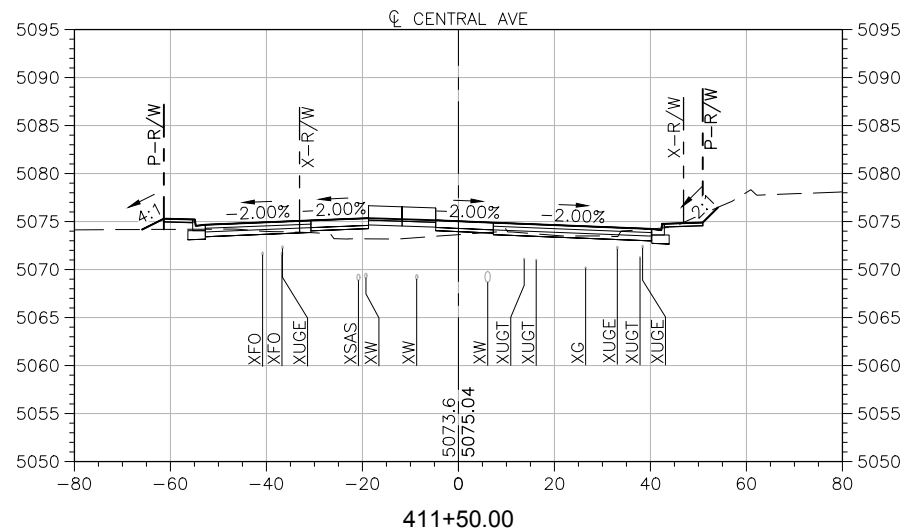
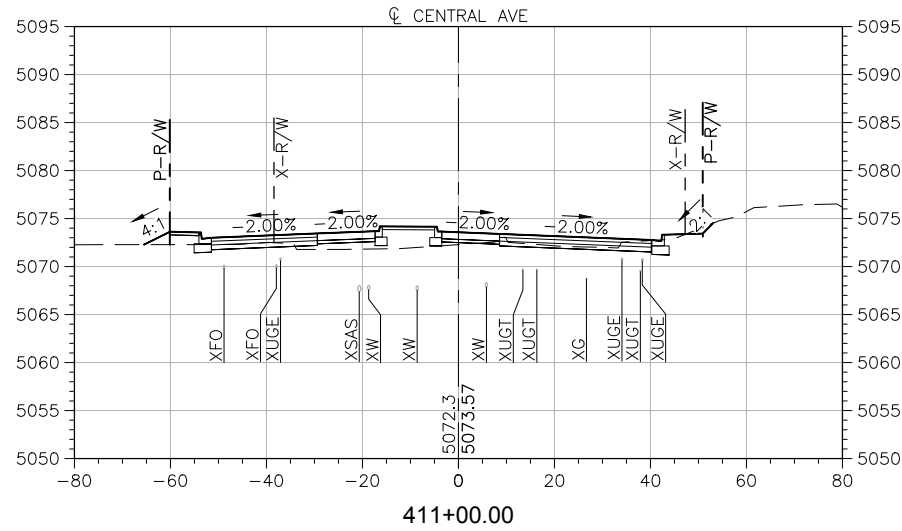

SURVEY INFORMATION		BENCHMARKS		AS BUILT INFORMATION	
NO.	FIELD NOTES	DATE	BY	CONTRACTOR	DATE
				5-K16A <td></td>	
				INSPECTOR'S <td></td>	
				DATE:	
				BRASS DISC SET FLUSH IN THE <td></td>	
				DATE:	
				SIDEWALK AND STAMPED "5-K16A" <td></td>	
				DATE:	
				THE MONUMENT IS LOCATED ON THE <td></td>	
				DATE:	
				NORTH SIDE OF CENTRAL AVE BETWEEN <td></td>	
				STANFORD DR AND COLUMBIA DR SE. <td></td>	
				NO.	
				NM SPC CENTRAL ZONE GRID: <td></td>	
				N: 1485016.971 USFT <td></td>	
				E: 1530495.993 USFT <td></td>	
				ELEV: 5174.054 <td></td>	

AMANDA M. GUTIERREZ
 NEW MEXICO
 20915
 PROFESSIONAL ENGINEER
Amanda M. Gutierrez
 JUN 17, 2016

NO.	DATE	REMARKS	BY
		REVISIONS	
		DESIGN	
		DESIGNED BY: AMG/ZAS	DATE: 06/2016
		DRAWN BY: AMG/ZAS	DATE: 06/2016
		CHECKED BY: ELP	DATE: 06/2016

CITY OF ALBUQUERQUE
 TRANSIT DEPARTMENT
 ABQ RIDE
 TITLE: CENTRAL AVENUE ALBUQUERQUE RAPID TRANSIT
 ROADWAY CROSS SECTIONS

Last Design Update	
Mo./Day/Yr.	Mo./Day/Yr.

CITY PROJECT NO. 631991 ZONE MAP NO. K15-K17 SEGMENT NO. S4 SHEET 5 OF 49

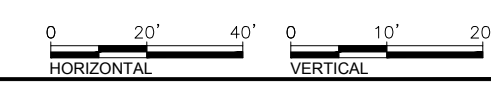

Date: 14 Jun 2016 11:54am User: ZSMARP Layout: C504
 Drawing Name: C501.dwg

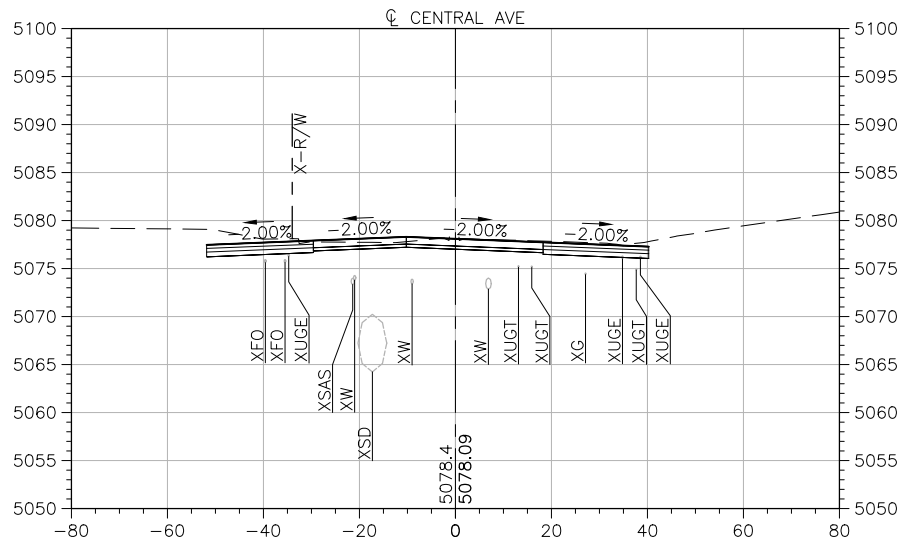

413+00.00

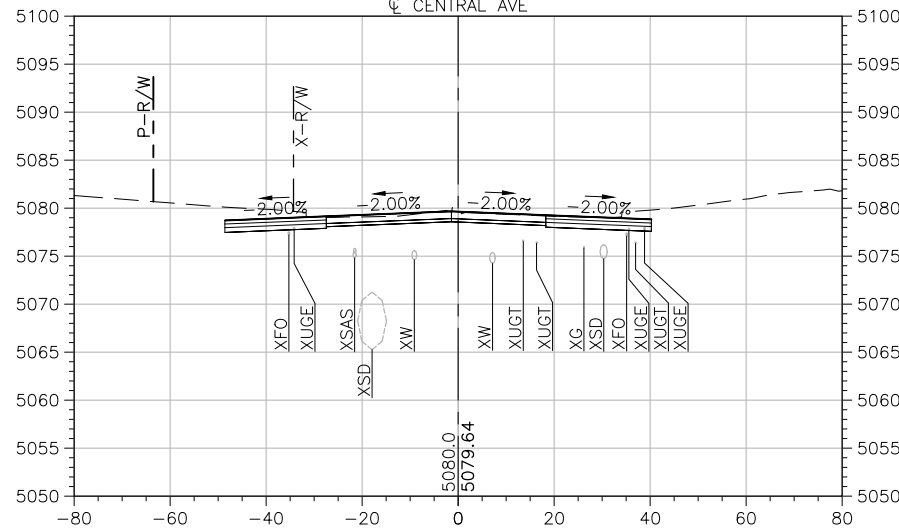

413+50.00

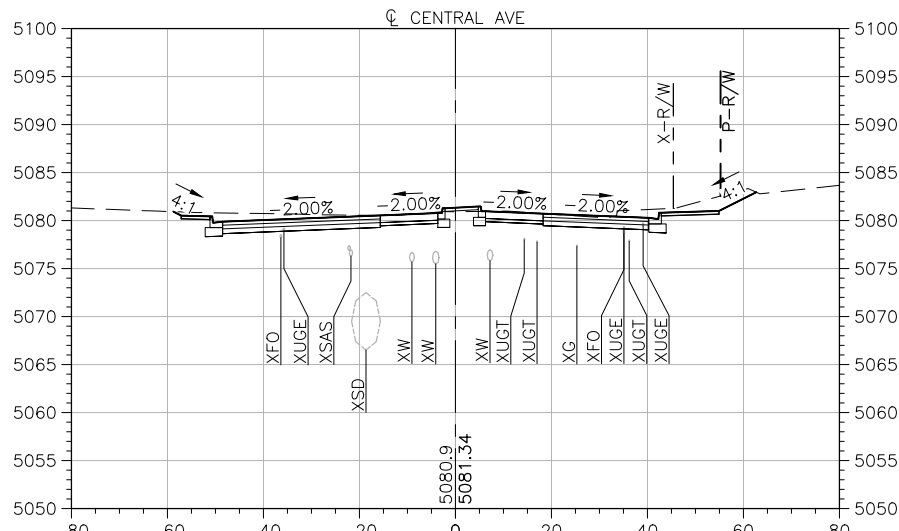

414+00.00

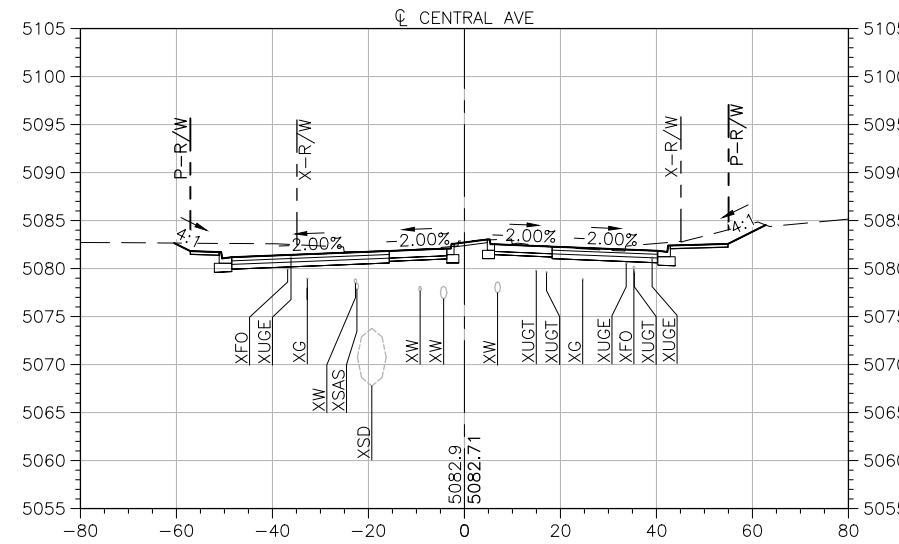

414+50.00

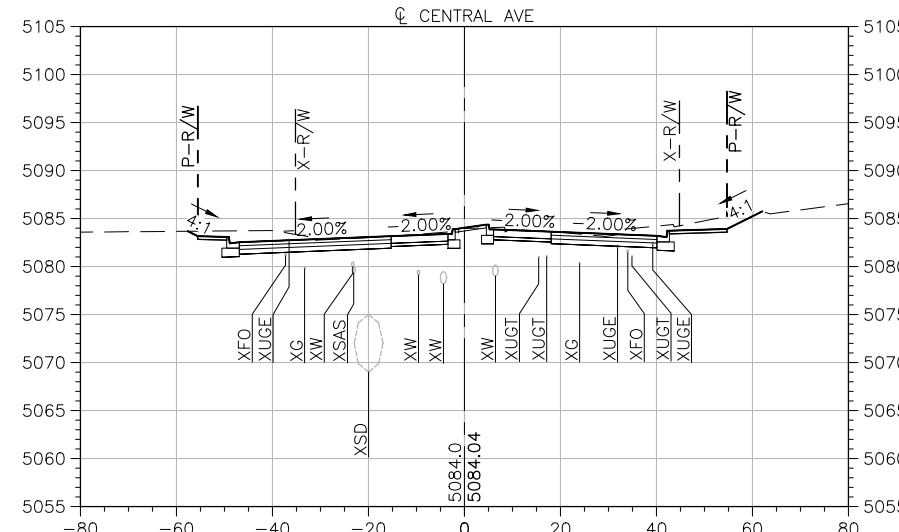

415+00.00

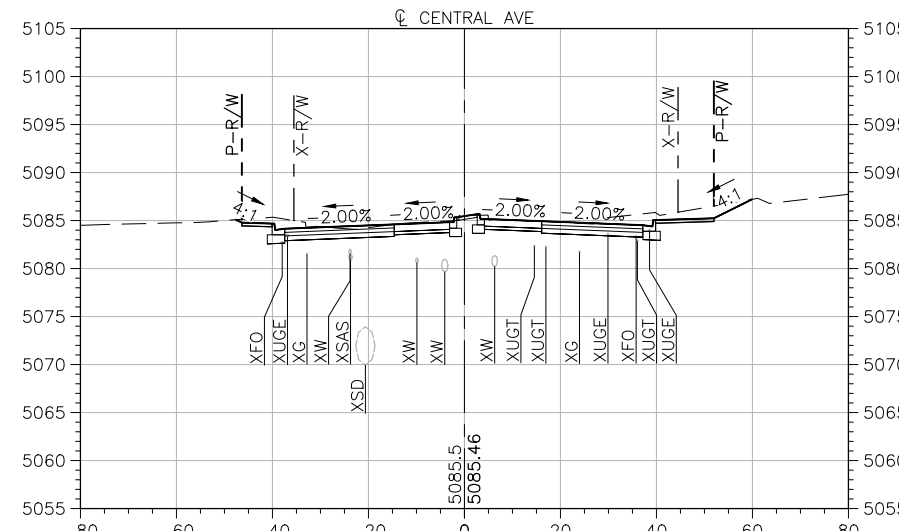

415+50.00

LEGEND

- EXISTING GROUND
- FINISHED GRADE
- [Symbol] COA STANDARD CURB & GUTTER & SIDEWALK
- [Symbol] COA MEDIAN CURB & GUTTER & LANDSCAPE OR MEDIAN PAVEMENT
- [Symbol] ART PAVEMENT SECTION
- [Symbol] MILL & OVERLAY
- [Symbol] ASPHALT CONCRETE PAVEMENT SECTION
- [Symbol] ART STATION
- (PRS EASE) PRESCRIPTIVE USE EASEMENT
- (P-R/W) PROPOSED RIGHT OF WAY
- (X-R/W) EXISTING RIGHT OF WAY

BENCHMARKS

PROJECT PRIMARY BENCHMARK: 5-K16A
 A CITY OF ALBUQUERQUE 2 INCH BRASS DISC SET FLUSH IN THE SIDEWALK AND STAMPED "5-K16A". THE MONUMENT IS LOCATED ON THE NORTH SIDE OF CENTRAL AVE BETWEEN STANFORD DR AND COLUMBIA DR SE.
 NM SPC CENTRAL ZONE GRID:
 N: 1485016.971 USFT
 E: 1530495.993 USFT
 ELEV: 5174.054

SURVEY INFORMATION

NO.	BY	DATE

AS BUILT INFORMATION

CONTRACTOR	DATE:
INSPECTOR'S	DATE:
ACCEPTANCE BY	DATE:
FIELD	DATE:
DRAWINGS	DATE:
CORRECTED BY	DATE:
RECORDED BY	DATE:
NO.	DATE:

REVISIONS

NO.	DATE	REMARKS	BY

DESIGNED BY: AMG/ZAS DATE: 06/2016
 DRAWN BY: AMG/ZAS DATE: 06/2016
 CHECKED BY: ELP DATE: 06/2016

HR 2155 LOUISIANA BLVD NE, SUITE 9500
 ALBUQUERQUE, NM 87110
 MAIN: (505) 830-5400
 FAX: (505) 830-5454

ABCORIDE CITY OF ALBUQUERQUE TRANSIT DEPARTMENT
 ABQ RIDE

TITLE: CENTRAL AVENUE ALBUQUERQUE RAPID TRANSIT
 ROADWAY CROSS SECTIONS

Mo./Day/Yr.	Mo./Day/Yr.

CITY PROJECT NO. 631991 ZONE MAP NO. K15-K17 SEGMENT NO. S4 SHEET 6 OF 49

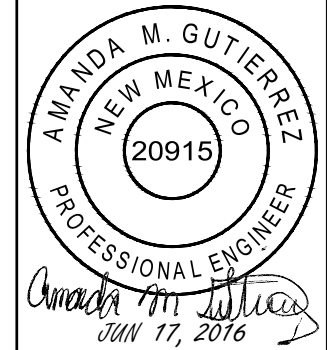

Date: 14 Jun 2016 11:55pm User: ZSM/EP Layout: C505 Drawing Name: C501.dwg



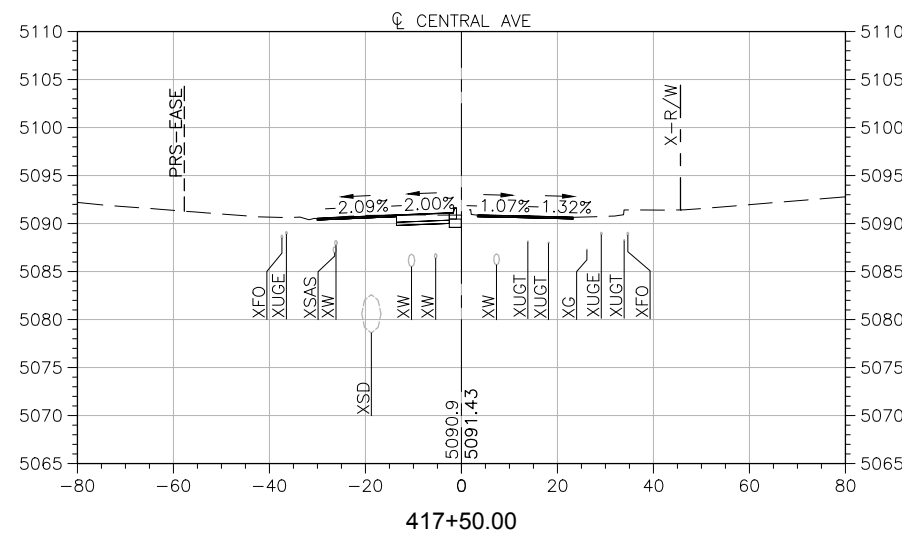
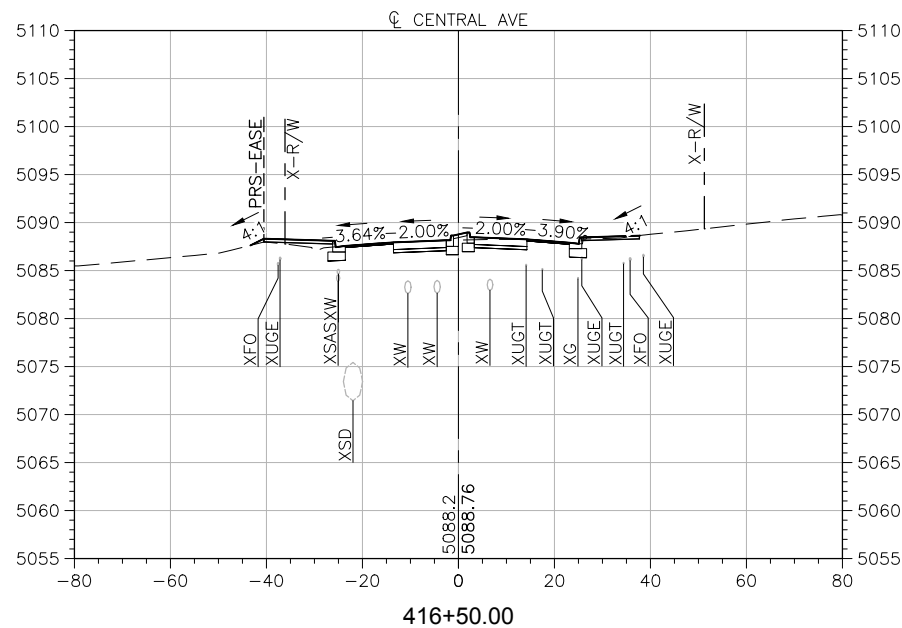
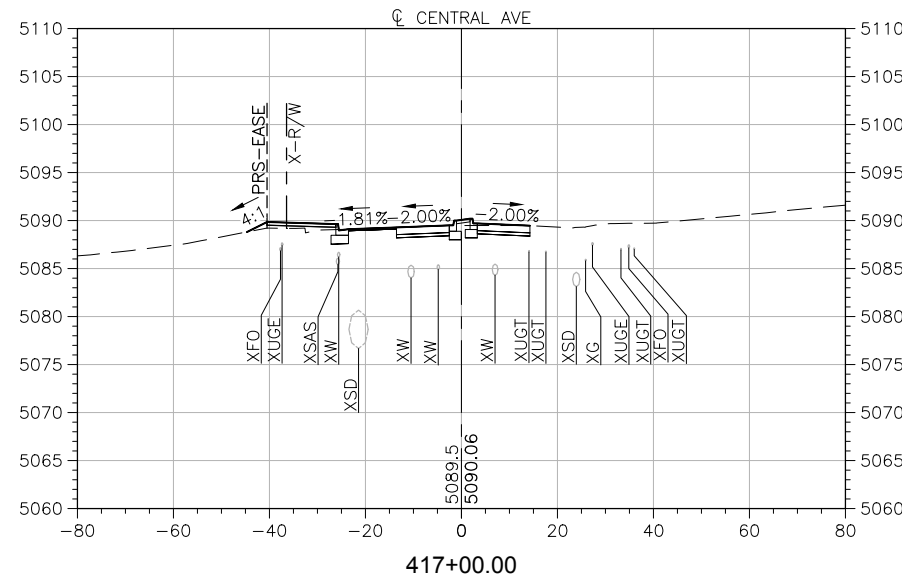
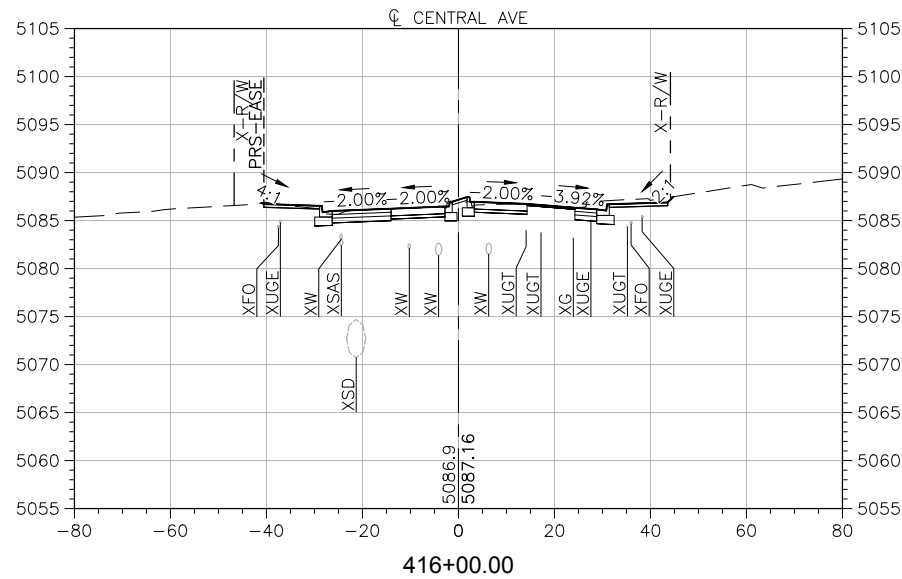

SURVEY INFORMATION		BENCHMARKS		AS BUILT INFORMATION	
NO.	FIELD NOTES BY	DATE	PROJECT PRIMARY BENCHMARK: 5-K16A	CONTRACTOR	DATE
			A CITY OF ALBUQUERQUE 2 INCH BRASS DISC SET FLUSH IN THE SIDEWALK AND STAMPED "5-K16A".		
			THE MONUMENT IS LOCATED ON THE NORTH SIDE OF CENTRAL AVE BETWEEN STANFORD DR AND COLUMBIA DR SE.		
			NW SPC CENTRAL ZONE GRID: N: 1485016.971 USFT E: 1530495.993 USFT ELEV: 5174.054		

LEGEND	
	EXISTING GROUND
	FINISHED GRADE
	COA STANDARD CURB & GUTTER & SIDEWALK
	COA MEDIAN CURB & GUTTER & LANDSCAPE OR MEDIAN PAVEMENT
	ART PAVEMENT SECTION
	MILL & OVERLAY
	ASPHALT CONCRETE PAVEMENT SECTION
	ART STATION
	(PRS EASE) PRESCRIPTIVE USE EASEMENT
	(P-R/W) PROPOSED RIGHT OF WAY
	(X-R/W) EXISTING RIGHT OF WAY

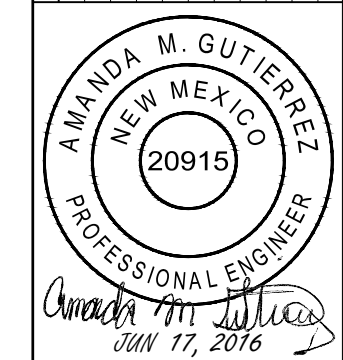

NO.	DATE	REMARKS	BY
		REVISIONS	
		DESIGN	

DESIGNED BY: AMG/ZAS	DATE: 06/2016
DRAWN BY: AMG/ZAS	DATE: 06/2016
CHECKED BY: ELP	DATE: 06/2016

HR 2155 LOUISIANA BLVD NE, SUITE 9500
ALBUQUERQUE, NM 87110
MAIN: (505) 830-5400
FAX: (505) 830-6454

ABC RIDE CITY OF ALBUQUERQUE TRANSIT DEPARTMENT
ABQ RIDE

TITLE: CENTRAL AVENUE ALBUQUERQUE RAPID TRANSIT
ROADWAY CROSS SECTIONS

CITY PROJECT NO.	ZONE MAP NO.	SEGMENT NO.	SHEET	OF
631991	K15-K17	S4	7	49

0 20' 40' HORIZONTAL
0 10' 20' VERTICAL

Date: 14 Jun 2016 11:55pm User: ZSMARP Layout: CS06
Drawing Name: CS01.dwg

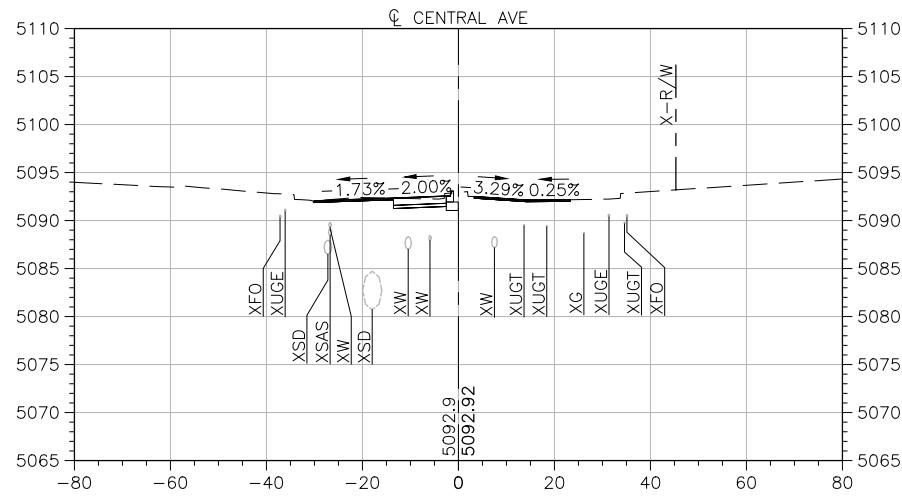

418+00.00

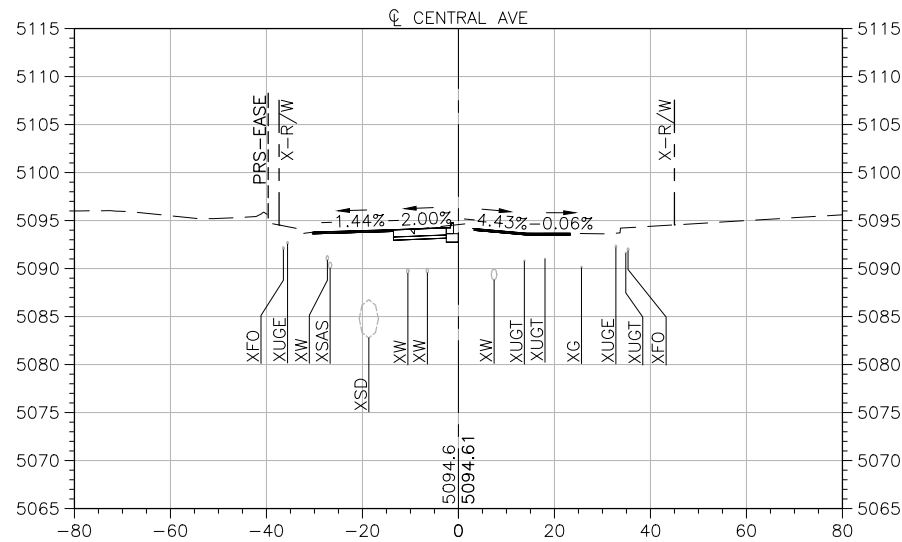

418+50.00

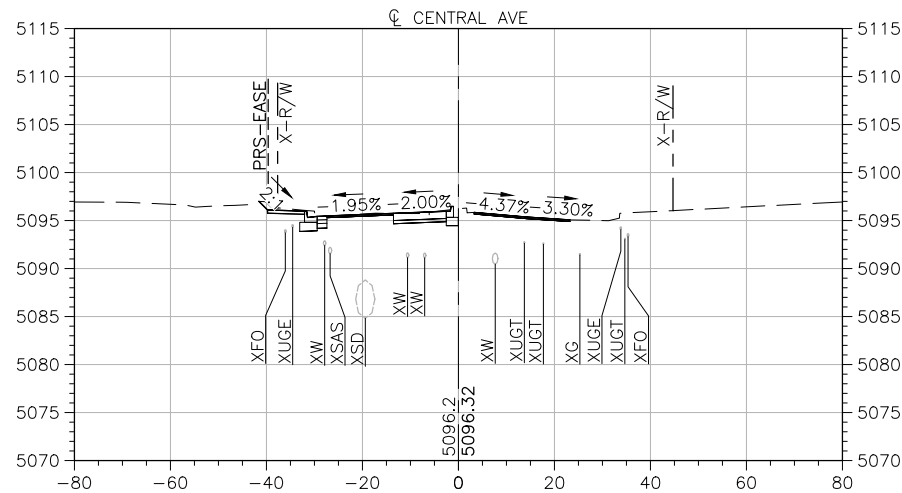

419+00.00

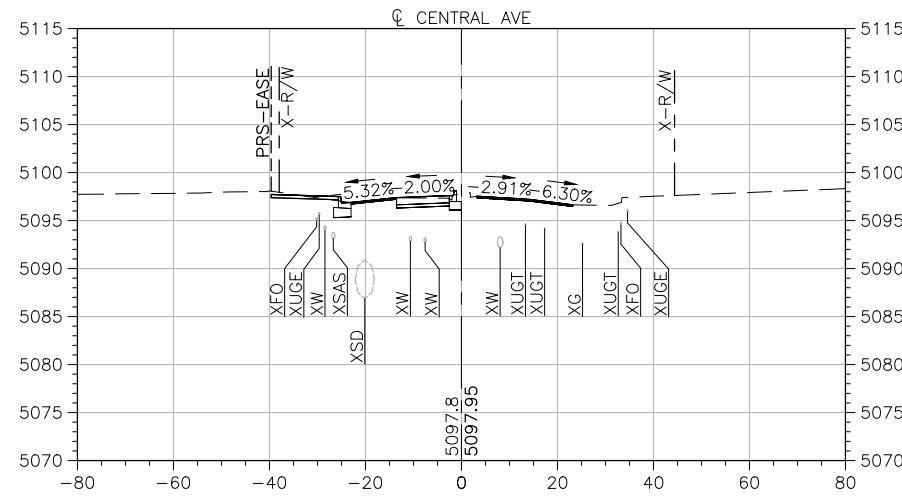

419+50.00

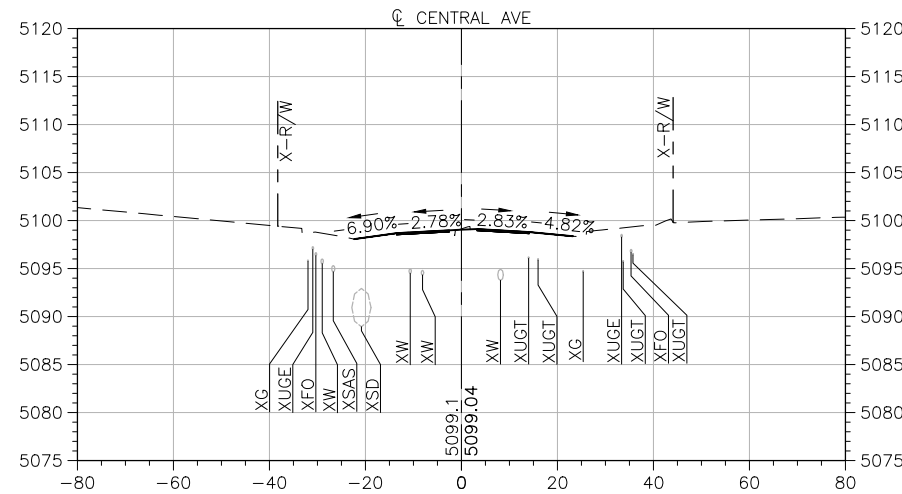

420+00.00

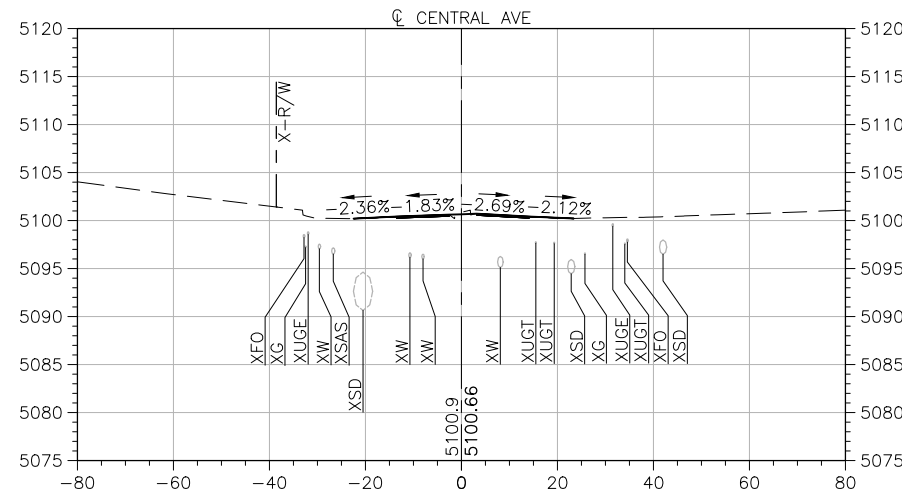

420+50.00

LEGEND

- EXISTING GROUND
- FINISHED GRADE
- COA STANDARD CURB & GUTTER & SIDEWALK
- COA MEDIAN CURB & GUTTER & LANDSCAPE OR MEDIAN PAVEMENT
- ART PAVEMENT SECTION
- MILL & OVERLAY
- ASPHALT CONCRETE PAVEMENT SECTION
- ART STATION
- (PRS EASE) PRESCRIPTIVE USE EASEMENT
- (P-R/W) PROPOSED RIGHT OF WAY
- (X-R/W) EXISTING RIGHT OF WAY

BENCHMARKS

PROJECT PRIMARY BENCHMARK: 5-K16A
 A CITY OF ALBUQUERQUE 2 INCH BRASS DISC SET FLUSH IN THE SIDEWALK AND STAMPED "5-K16A". THE MONUMENT IS LOCATED ON THE NORTH SIDE OF CENTRAL AVE BETWEEN STANFORD DR AND COLUMBIA DR SE.
 NM SPC CENTRAL ZONE GRID:
 N: 1485016.971 USFT
 E: 1530495.993 USFT
 ELEV: 5174.054

SURVEY INFORMATION

NO.	FIELD NOTES	BY	DATE

AS BUILT INFORMATION

CONTRACTOR	DATE

REVISIONS

NO.	DATE	REMARKS	BY

DESIGNED BY: AMG/ZAS DATE: 06/2016
 DRAWN BY: AMG/ZAS DATE: 06/2016
 CHECKED BY: ELP DATE: 06/2016

Professional Engineer Seal: AMANDA M. GUTIERREZ, NEW MEXICO, 20915, PROFESSIONAL ENGINEER. Signature: Amanda M. Gutierrez, JUN 17, 2016.

HR 2155 LOUISIANA BLVD NE, SUITE 9500 ALBUQUERQUE, NM 87110 MAIN: (505) 830-5400 FAX: (505) 830-6454

ABC RIDE CITY OF ALBUQUERQUE TRANSIT DEPARTMENT ABQ RIDE

TITLE: CENTRAL AVENUE ALBUQUERQUE RAPID TRANSIT ROADWAY CROSS SECTIONS

Mo./Day/Yr.	Mo./Day/Yr.

CITY PROJECT NO. 631991 ZONE MAP NO. K15-K17 SEGMENT NO. S4 SHEET 8 OF 49

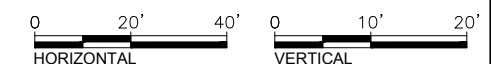

Date: 14 Jun 2016 11:56am User: ZSMARP Layout: C507 Drawing Name: C501.dwg

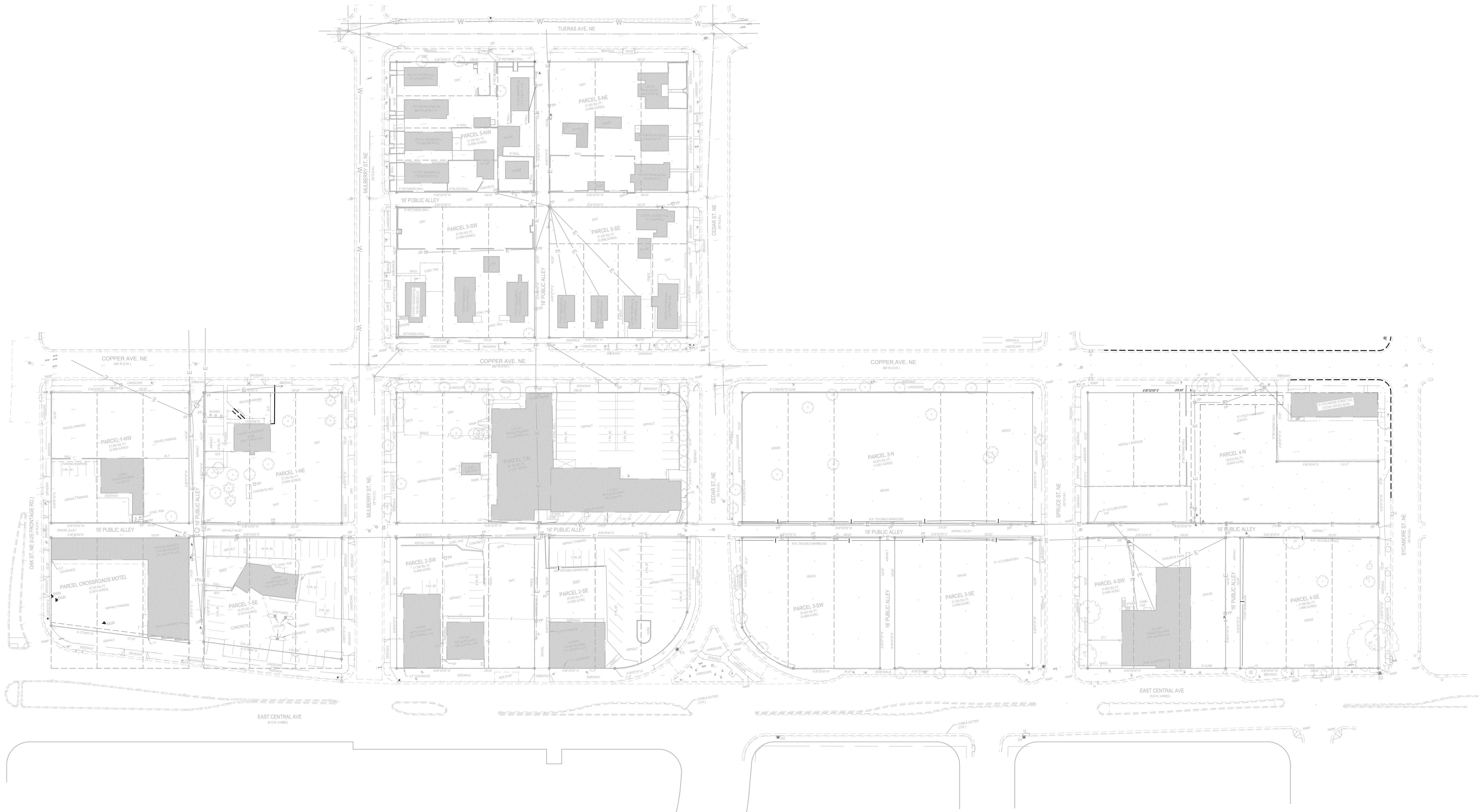

INTERSTATE 25

P:\20160155\CDP\Design\Workarea\Site Sketch_Plot.dwg
 April 24, 2017 - 2:51pm
 Site Sketch

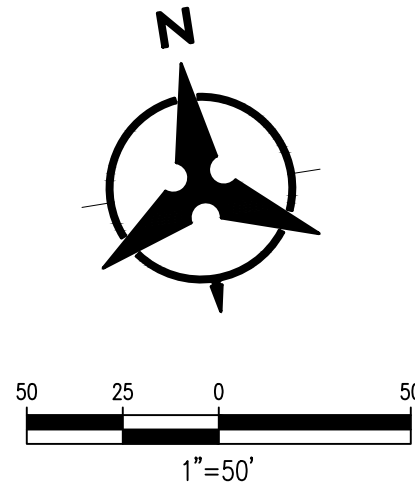

THE HIGHLANDS			
EXISTING SITE SKETCH			
DRAWN BY:	EGN	DATE:	04/25/2017
CHECKED BY:	MJB	PROJECT NO.	20160155
		SHEET NO.	1 of 1

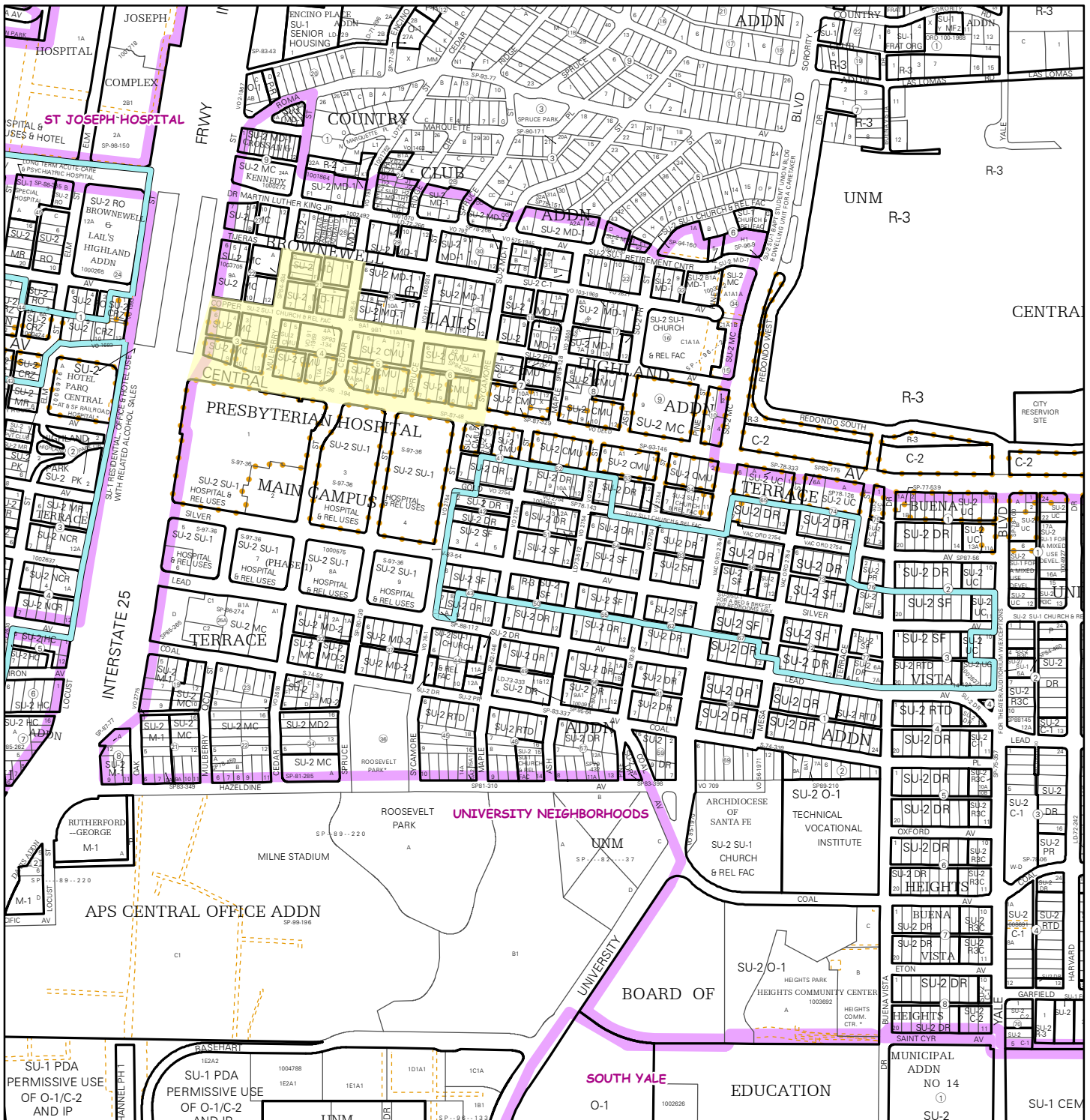

For more current information and details visit: <http://www.cabq.gov/gis>

Map amended through: 1/28/2016

Note: Grey Shading Represents Area Outside of the City Limits

Zone Atlas Page:
K-15-Z

Selected Symbols

SECTOR PLANS	Escarpment
Design Overlay Zones	2 Mile Airport Zone
City Historic Zones	Airport Noise Contours
H-1 Buffer Zone	Wall Overlay Zone
Petroglyph Mon.	