

**SITE INFORMATION:**

- EXISTING LEGAL: LOTS 18 & 19 ALVARADO GARDENS UNIT 1  
 ZONING: RA-2  
 TOTAL AREA: 2.1 AC.
- PROPOSED:
- 8 LOTS
  - OPEN SPACE (0.67 AC)
  - 24' PRIVATE ACCESS
  - 24' PRIVATE ACCESS EASMENT (VARIANCE-38' PER DPM)
  - NO SIDEWALKS (VARIANCE-TWO 4' SDWKS PER DPM)

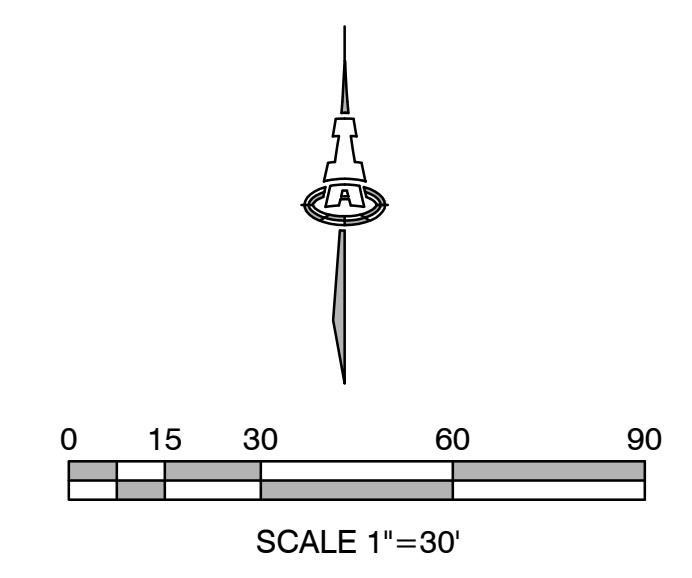
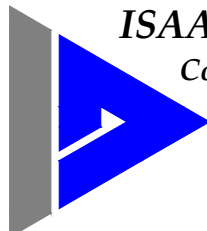

 <b>ISAACSON &amp; ARFMAN, P.A.</b> Consulting Engineering Associates 128 Monroe Street N.E. Albuquerque, New Mexico 87108 Ph. 505-268-8828 www.iacivil.com			
2224 C-701-SKETCH PLAT.dwg Apr 11, 2017			
<small>This design, calculations, and concepts are owned by and remain the property of Isaacson &amp; Arfman, P.A. and no part thereof shall be utilized by any person, firm or corporation for any purpose whatsoever except with the written permission of Isaacson &amp; Arfman, P.A. ©</small>			
<b>8-LOT SUBDIVISION          AT CAMPBELL RD          LAS VENTANAS HOMES</b>			
<b>SKETCH PLAT</b>			
Date:	No. Revision:	Date:	Job No.
04/11/17			2224
Drawn By:			PAGE
Chd By:			SH. OF