

13 BIKE RACK
NT.S

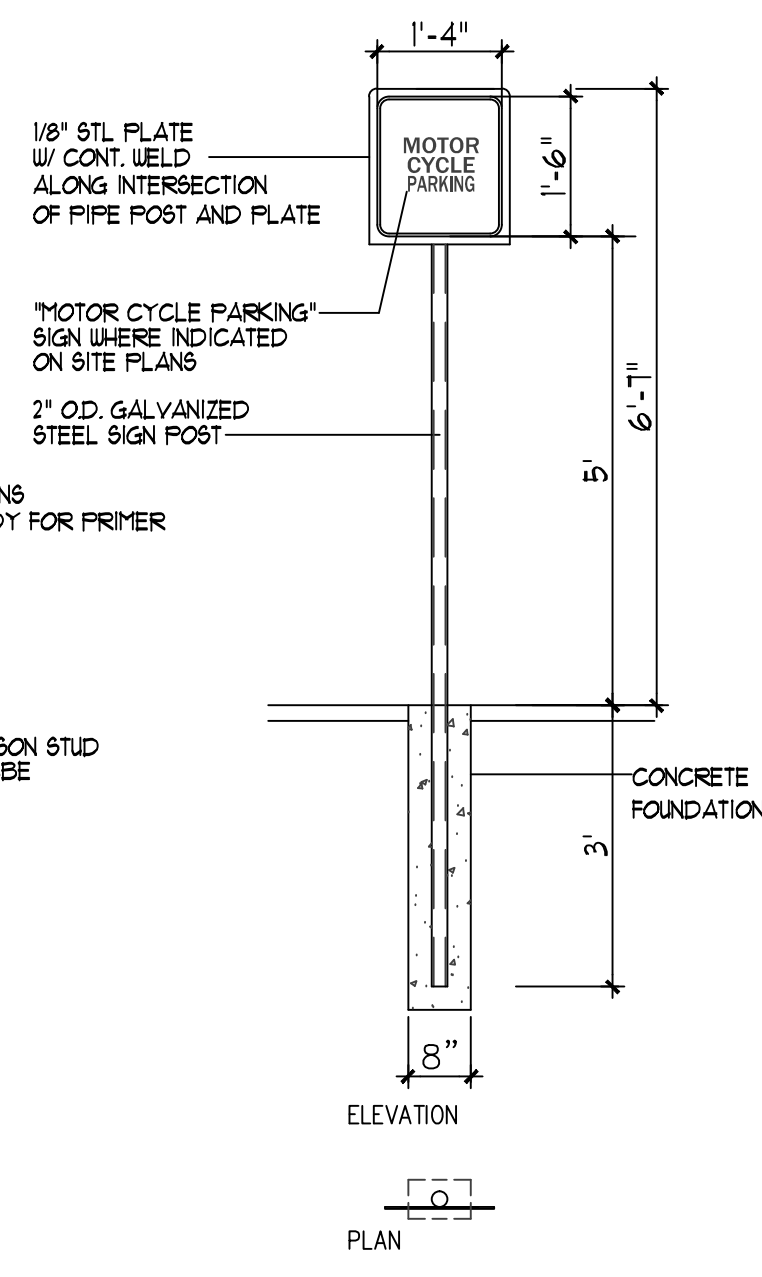

12 MISC. SIGNAGE
NT.S

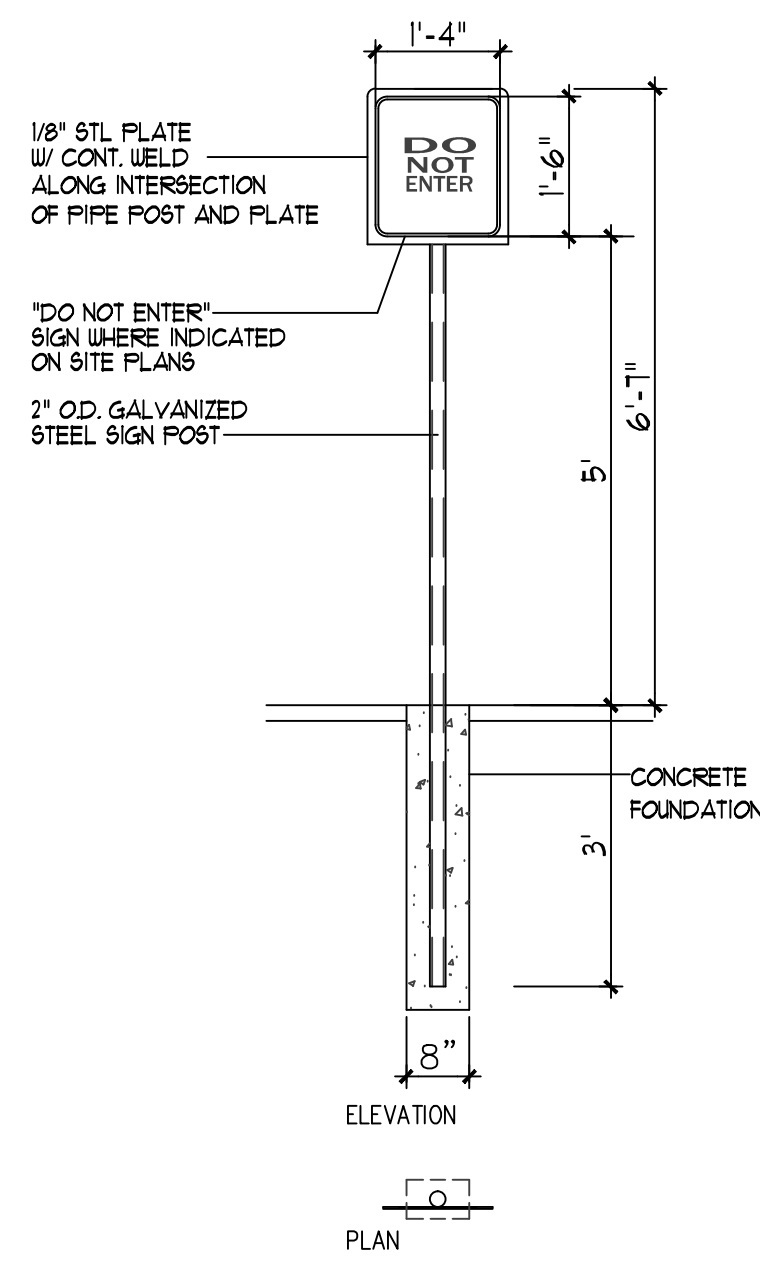

12A MISC. SIGNAGE
NT.S

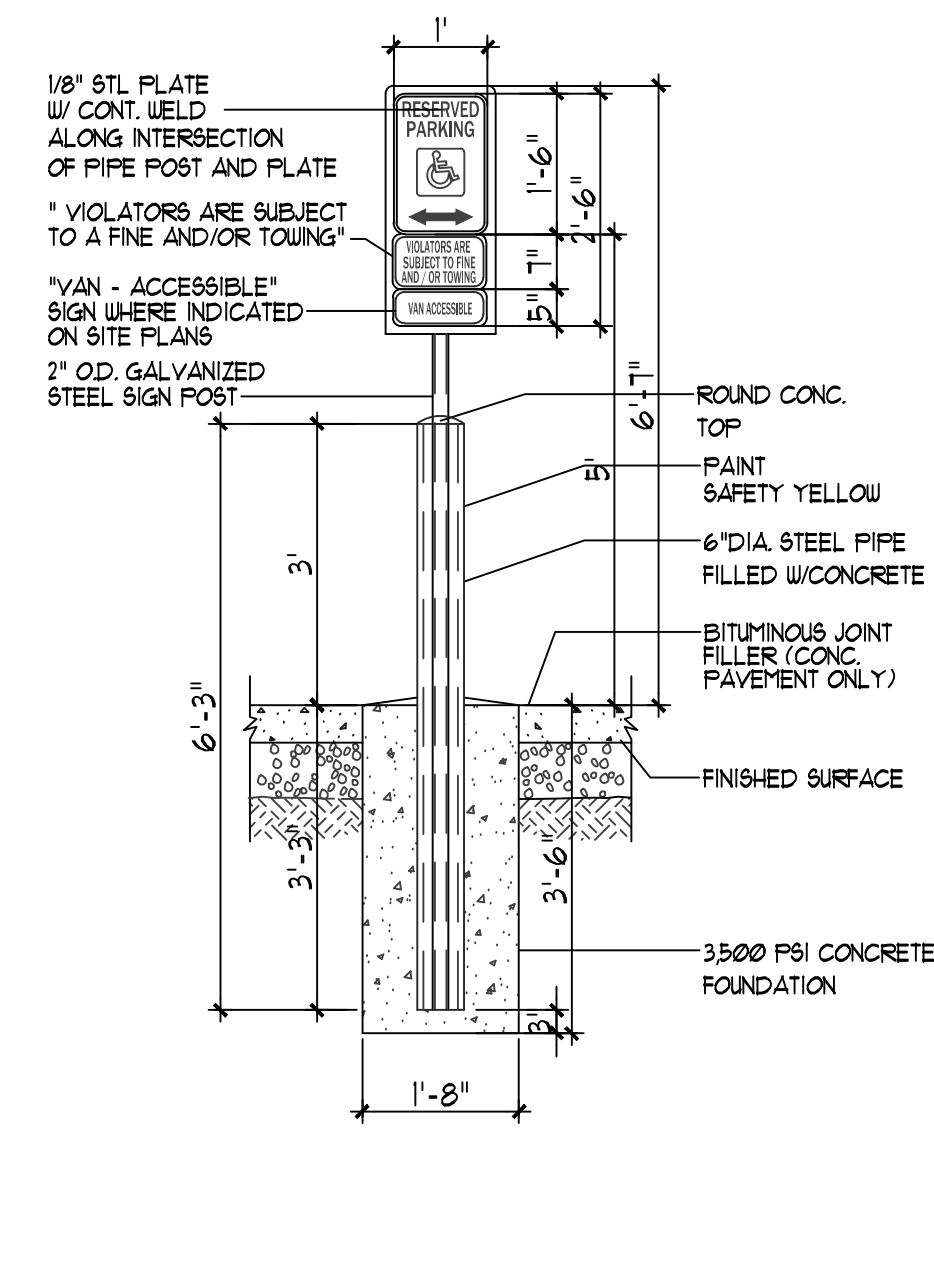

11 H.C SIGNAGE
NT.S

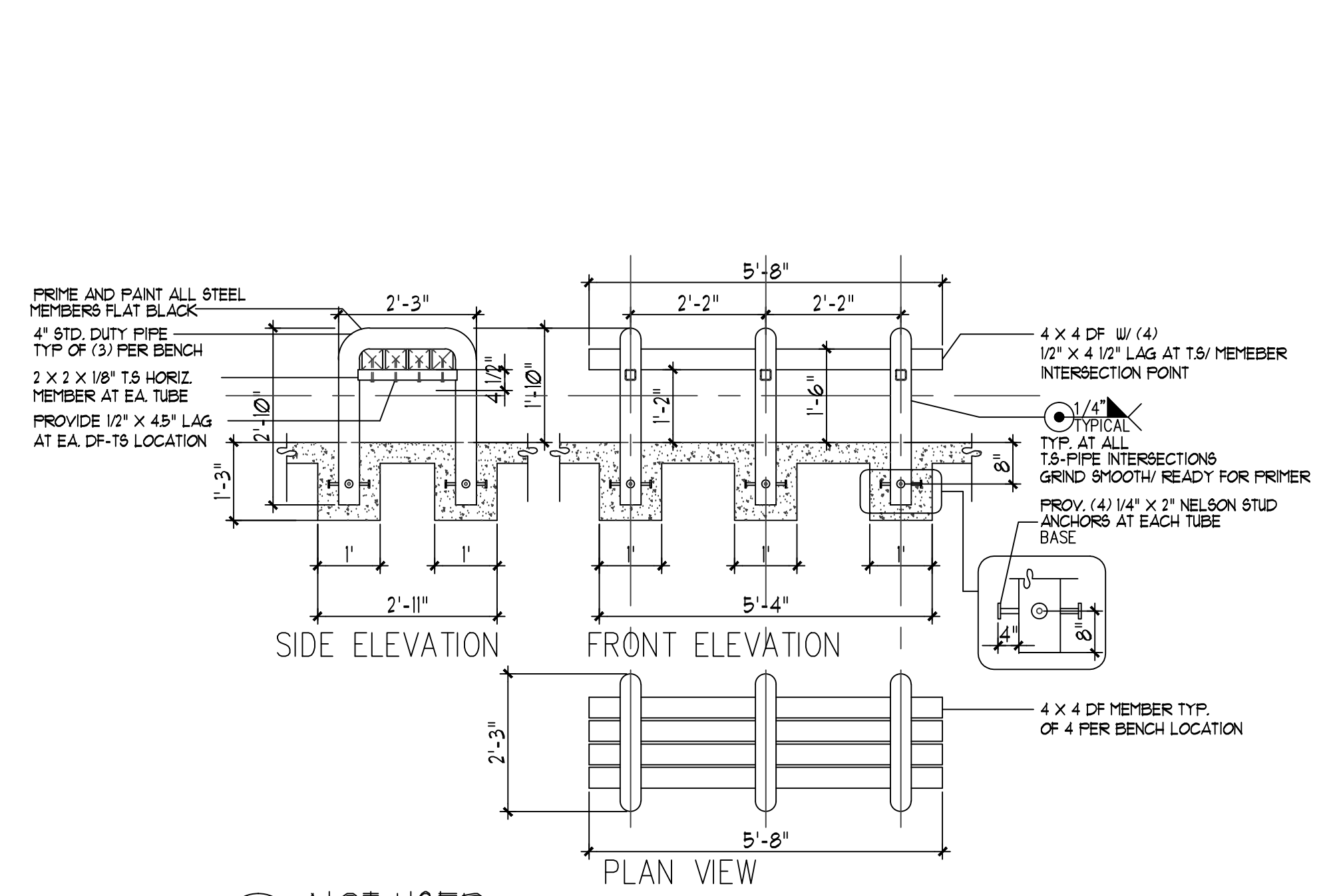

10 NOT USED
NT.S

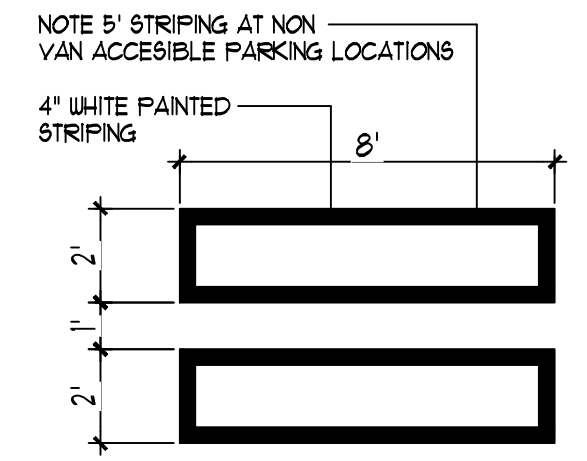

9 H.C. PARKING-WALK PAINT DETAIL
NT.S

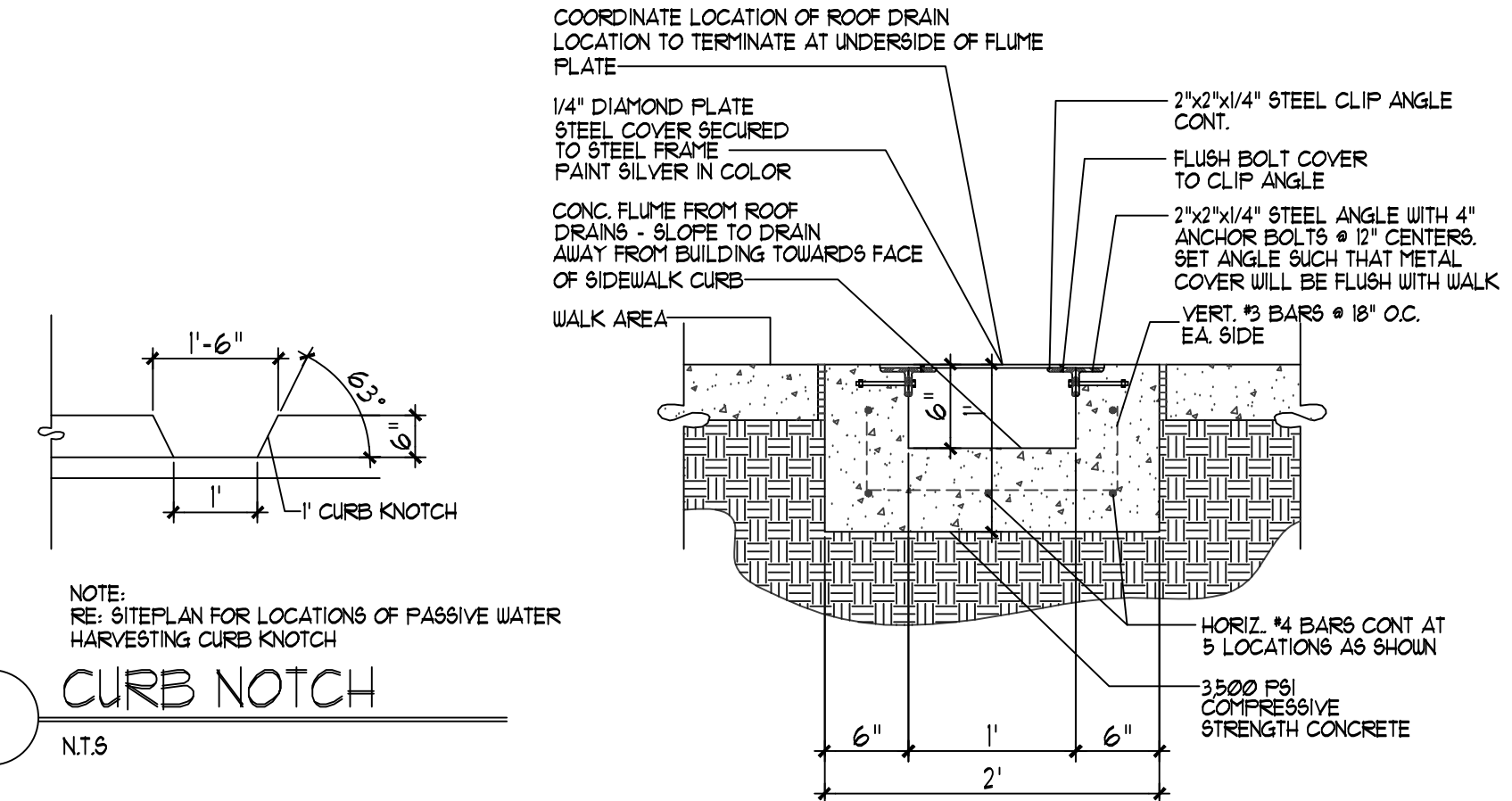

7 CURB NOTCH
NT.S

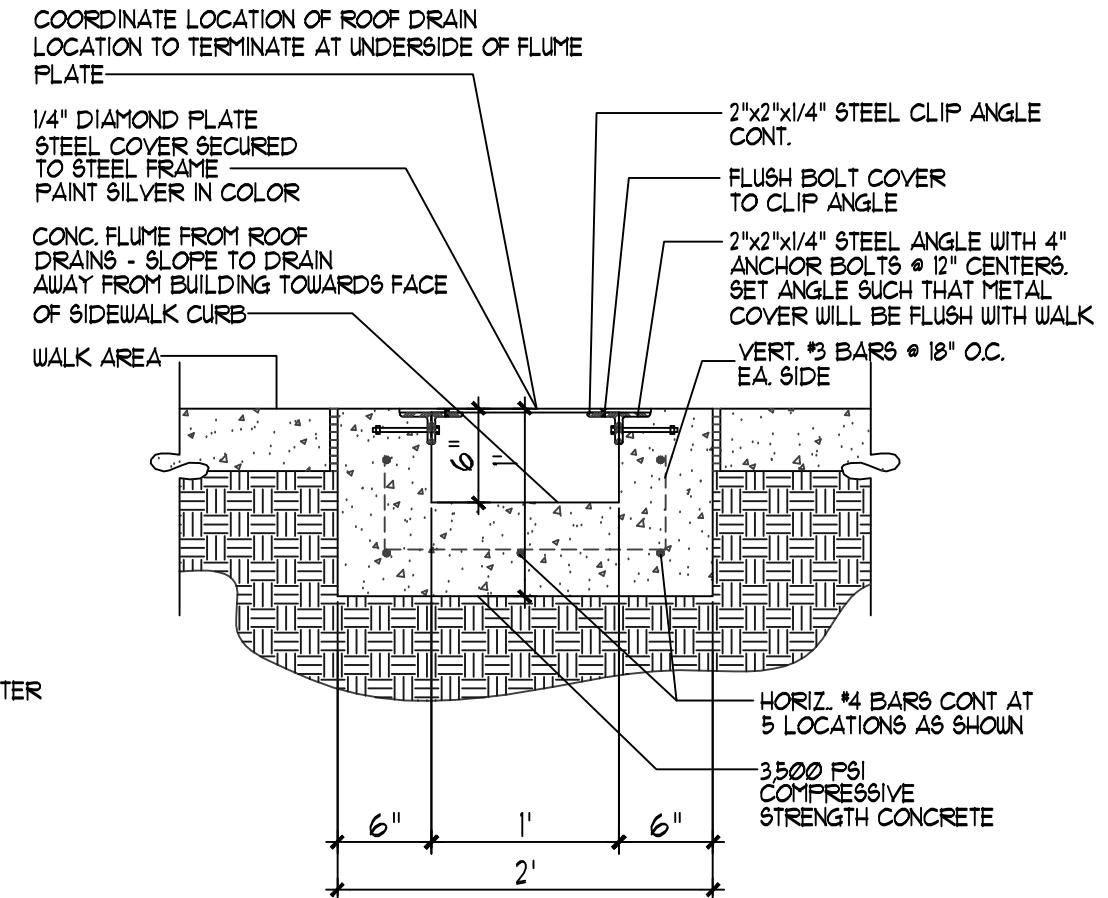

6 CONCRETE FLUME DETAIL
NT.S

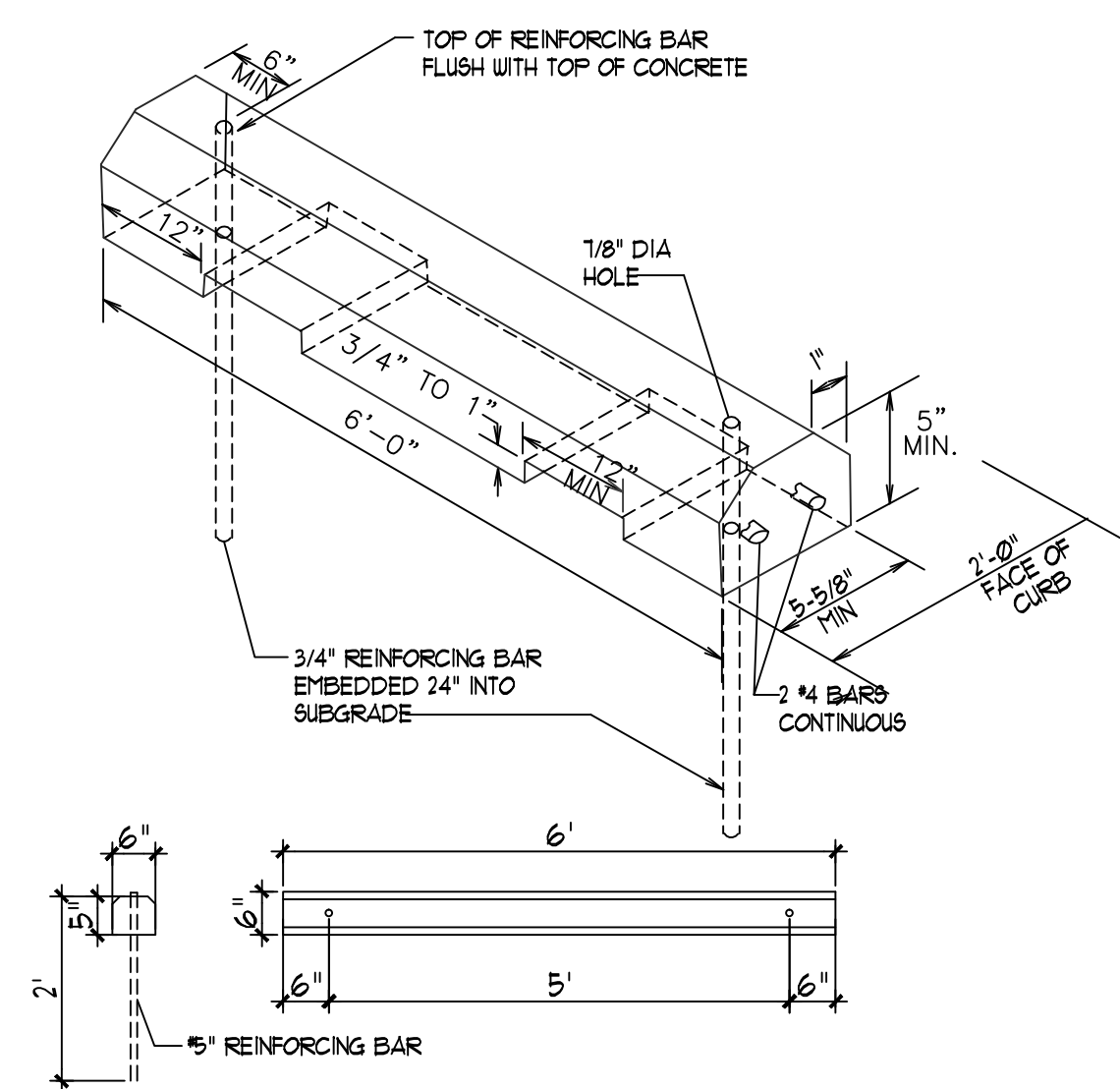

4 WHEEL STOP
NT.S

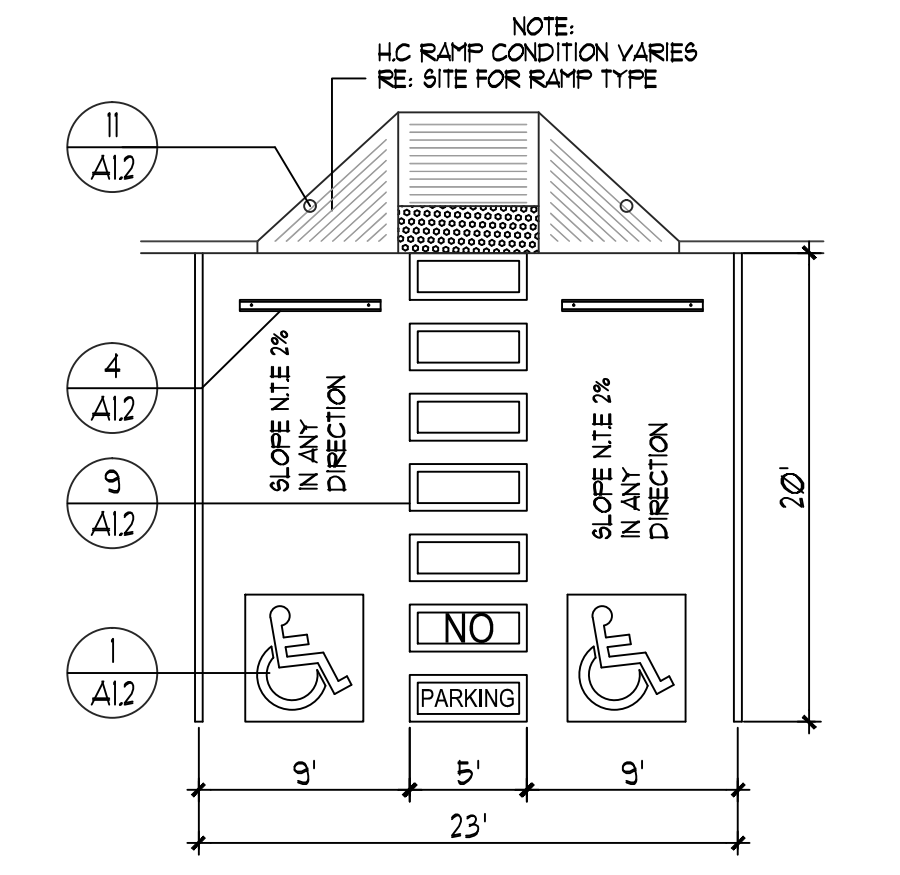

3 H.C. PARKING PLAN DETAIL
NT.S

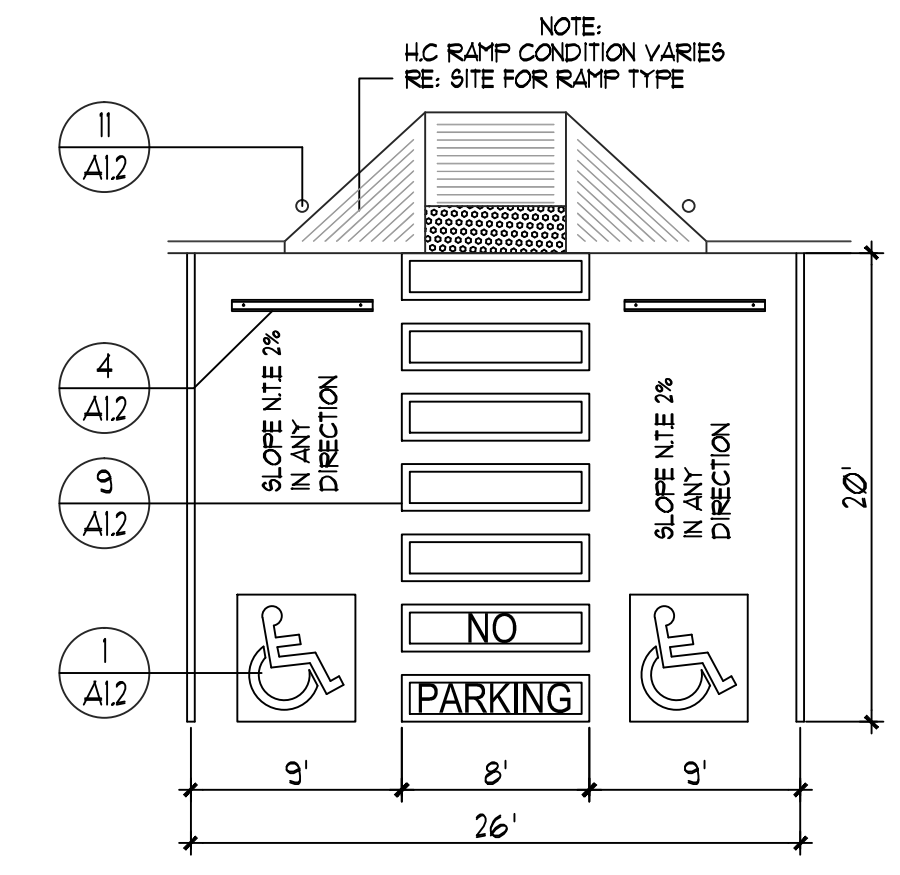

2 H.C. PARKING PLAN DETAIL (VAN ACCESSIBLE)
NT.S

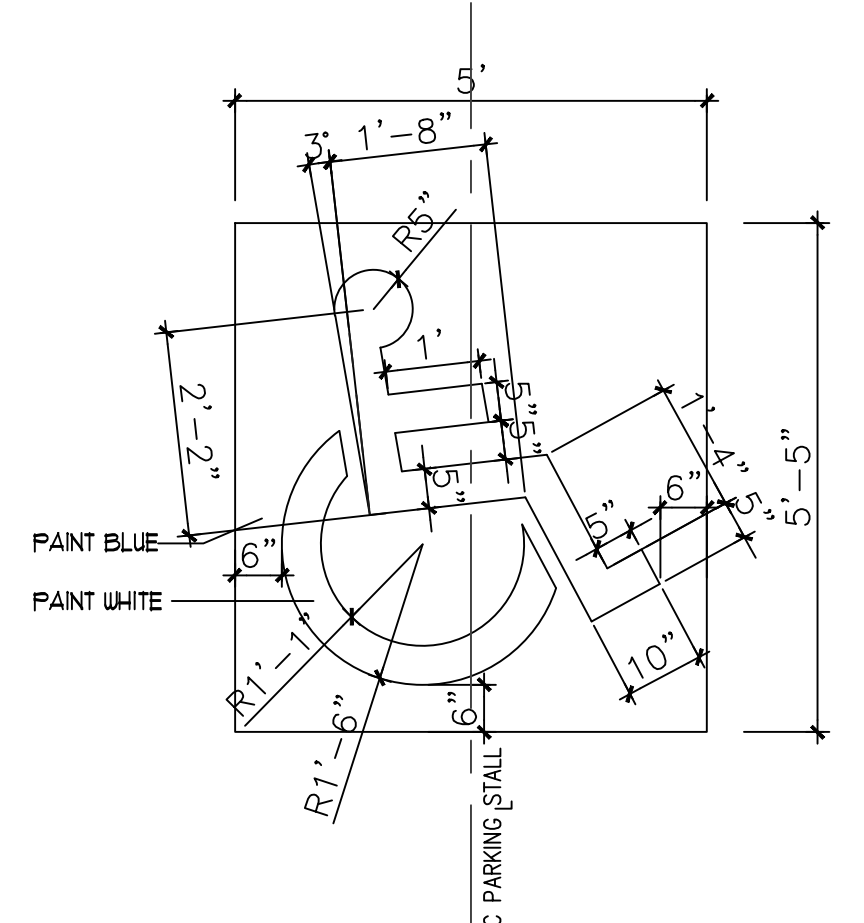

1 H.C. SIGNAGE
NT.S

REV	DATE	BY	REVISION
1			
2			
3			
4			
5			
6			
7			
8			
9			
10			
11			
12			
13			
14			
15			

MODULUS ARCHITECTS
 100 SUN AVE. N.W. SUITE 305
 ALBUQUERQUE, NEW MEXICO 87109
 PHONE (505) 338-1499 FAX (505) 338-1498

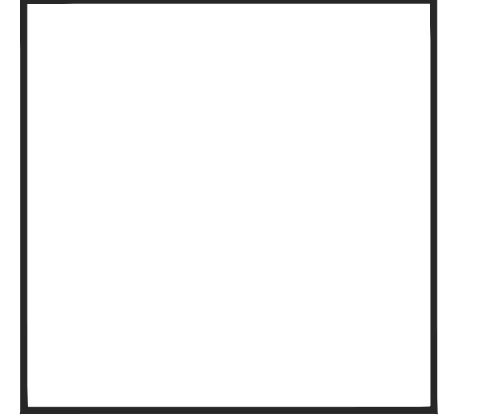

PROJECT TITLE	PROJECT 1-25	DATE	8/04/2017
PROJECT MANAGER	STEPHEN DUNBAR, AIA	SCALE	RE:BAR SCALE
JOB NO.	PROJECT-125	DRAWN BY:	SJAF
SHEET TITLE	SITE DETAILS	SHEET NO.	A1.2

DATE:	8/04/2017
SCALE:	RE:BAR SCALE
SHEET NO.:	A1.2