

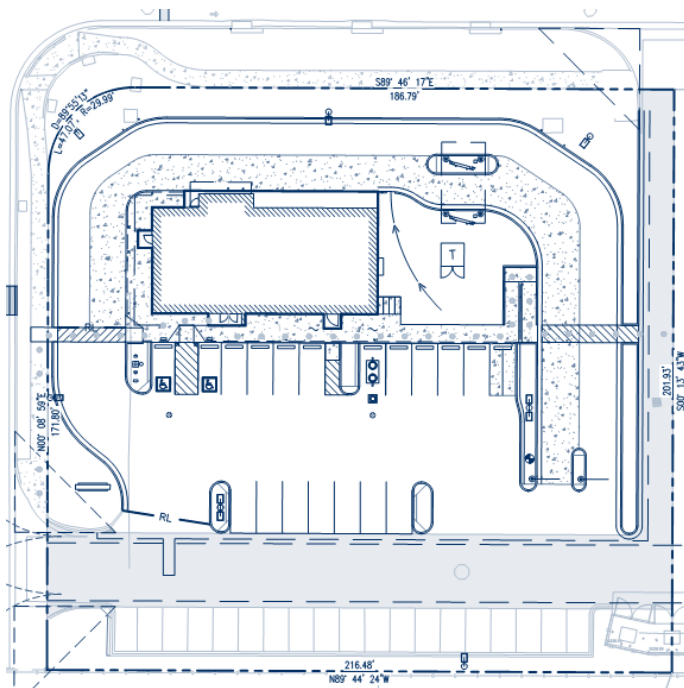

Whataburger

Traffic Impact Study



HT#C18D086C
Received 2/8/2022

Prepared for:



Sustainability Engineering Group
8280 E. Gelding Drive, Suite 101
Scottsdale, AZ 85260



Prepared by:



Lokahi, LLC
10555 N. 114th Street, Suite 105
Scottsdale, AZ 85259

Project Number: 21.5267
January 28, 2022



Table of Contents:

- 1. Introduction and Executive Summary1**
 - 1.1. Purpose of Report and Study Objectives1
 - 1.2. Executive Summary.....1
- 2. Proposed Development5**
- 3. Area Conditions8**
 - 3.1. Study Roadway Segments.....8
 - 3.2. Study Intersections8
 - 3.3. Study Area Land Use.....9
 - 3.4. Site Accessibility 10
- 4. Existing Conditions.....12**
 - 4.1. Existing Land Use12
 - 4.2. Existing Traffic Counts12
 - 4.3. Existing Capacity Analysis..... 14
- 5. Projected Traffic..... 16**
 - 5.1. Trip Generation..... 16
 - 5.2. Trip Generation Comparison17
 - 5.3. Trip Distribution and Assignment 18
- 6. Future Conditions (Year 2022 – Opening Year)..... 22**
 - 6.1. Year 2022 Background Traffic Volumes 22
 - 6.2. Year 2022 Build Traffic Volumes 22
 - 6.3. Year 2022 Build Capacity Analysis..... 22
- 7. On-Site Circulation and Queue26**
- 8. Recommendations & Conclusions.....28**





Figures:

Figure 1 – Vicinity Map	6
Figure 2 – Site Plan	7
Figure 3 – Study Area	11
Figure 4 – Existing Traffic Volumes	13
Figure 5 – Existing Capacity Analysis	15
Figure 6 – Trip Distribution	19
Figure 7 – Site Traffic Volumes	20
Figure 8 – Pass-By Traffic Volumes	21
Figure 9 – Year 2022 Background Traffic Volumes	23
Figure 10 – Year 2022 Build Traffic Volumes	24
Figure 11 – Year 2022 Build Capacity Analysis	25
Figure 12 – On-Site Queue	27

Tables:

Table 1 – Level of Service Criteria	14
Table 2 – Trip Generation (Proposed Development)	16
Table 3 – Trip Generation (Previously Approved)	17
Table 4 – Trip Generation Comparison	17

Appendices:

Appendix A – Proposed Site Plan	A
Appendix B – Parcel Information	B
Appendix C – Traffic Count Data	C
Appendix D – Existing Capacity Analysis	D
Appendix E – Trip Generation	E
Appendix F – Previously Approved Site	F
Appendix G – United States Census Bureau Data	G
Appendix H – Year 2022 Build Capacity Analysis	H



1. INTRODUCTION AND EXECUTIVE SUMMARY

1.1. PURPOSE OF REPORT AND STUDY OBJECTIVES

Lōkahi, LLC (Lōkahi) was retained by Sustainable Engineering Group to complete a Traffic Impact Study (TIS) for the proposed Whataburger development. The proposed development is located on the southeast corner of Alameda Boulevard and San Pedro Avenue in the City of Albuquerque, New Mexico. See **Figure 1** for the vicinity map.

The proposed Whataburger development is comprised of a 2,999 square foot fast-food restaurant. Additionally, the proposed development will provide two (2) vehicle queuing lanes for the drive-through.

The objective of this TIS is to analyze the traffic related impacts of the proposed development to the adjacent roadway network.

This Traffic Impact Analysis includes:

- Level of service analysis of existing conditions for the weekday AM and PM peak hours
- Trip generation for the proposed development
- Trip generation comparison (proposed development versus previously approved)
- Level of service analysis for the opening year (2022) weekday AM and PM peak hours

The following are the intersections included in this study:

- Alameda Boulevard and San Pedro Drive (1)
- Alameda Boulevard and Driveway A (2)
- Alameda Boulevard and Driveway B (3)
- San Pedro Drive and Driveway C (4)
- San Pedro Drive and Signal Avenue (5)

1.2. EXECUTIVE SUMMARY

This report presents the analyses and results of a Traffic Impact Study prepared for the proposed Whataburger development. The proposed development is generally located on the southeast corner of Alameda Boulevard and San Pedro Avenue in the City of Albuquerque, New Mexico. The proposed Whataburger development is comprised of a 2,999 square foot fast-food restaurant. Additionally, the proposed development will provide two (2) vehicle queuing lanes for the drive-through.



Existing Capacity Analysis

The AM and PM peak hour existing conditions capacity analysis were completed for the existing study intersections. The results of the existing capacity analysis reveal that all movements operate at an existing level of service (LOS) D or better.

Trip Generation

The trip generation for the proposed Whataburger development was calculated utilizing the Institute of Transportation Engineers (ITE) publication entitled *Trip Generation, 11th Edition*. ITE Land Use 934 – Fast-Food Restaurant with Drive-Through Window was used to calculate the trips generated by the proposed development.

Trip Generation – Proposed Development

Land Use	ITE Code	Qty	Unit	Weekday	AM Peak Hour			PM Peak Hour		
				Total	Total	In	Out	Total	In	Out
Fast-Food Restaurant with Drive-Through Window	934	2.999	1000 SF GFA	1,402	134	68	66	99	51	48
Pass-By Trips				687	66	33	32	50	26	24
Total New Trips				715	68	35	34	50	26	24

The proposed Whataburger development is anticipated to generate 715 new weekday trips, with 68 trips occurring during the AM peak hour and 50 occurring during the PM peak hour. For fast-food restaurants with drive-through windows it is expected that a portion of the patrons are from pass-by trips. These are trips that are intermediate stops on the way from an origin to a primary trip destination without route diversion. Pass-by rates were applied to the Weekday, AM Peak Hour and PM Peak Hour trips. These rates are based on data provided in the *Trip Generation Handbook, 3rd Edition*.





Trip Generation Comparison

A trip generation comparison was calculated between the proposed Whataburger development and the previously approved 3,000 square foot restaurant.

Trip Generation Comparison

Land Use	ITE Code	Qty	Unit	Weekday	AM Peak Hour			PM Peak Hour		
				Total	Total	In	Out	Total	In	Out
Fast-Food Restaurant with Drive-Through Window	934	2,999	1000 SF GFA	1,402	134	68	66	99	51	48
Pass-By Trips				687	66	33	32	50	26	24
Proposed Site New Trips				715	68	35	34	50	26	24
High-Turnover (Sit-Down) Restaurant	932	3,000	1000 SF GFA	322	29	16	13	27	16	11
Previously Approved Site Trips				322	29	16	13	27	16	11
Difference				393	39	19	21	23	10	13

The build-out of the Whataburger development is anticipated to generate 393 (55%) more weekday trips, with 39 (58%) more trips during the AM peak hour, and 23 (45%) more trips during the PM peak hour than build out of the previously approved 3,000 square foot restaurant.

Future Background Traffic Volumes

Future capacity analyses were completed with the buildout of the proposed Whataburger development for the opening year, year 2022. The year 2022 background traffic volumes include a 1.0% annual growth rate based on United States Census Bureau population data.

Year 2022 – Opening Year

A capacity analysis was completed for both the AM and PM peak hours for the year 2022, with the build-out of the proposed Whataburger development. The year 2022 build capacity analysis resulted in all movements continuing to operate at a LOS D or better during the AM and PM peak hours.

On-Site Circulation and Queue

The two (2) vehicle queuing lanes provide approximately 460 feet of storage length, which equates to a minimum of 18 vehicles of storage. This site and drive-through queue lengths have been designed consistently with other Whataburger locations and is based on the successful on-site circulation and processing of drive-through queuing.



Recommendations

Beyond the build out of the proposed Whataburger site with two (2) vehicle queuing lanes for the drive-through, there are no other transportation infrastructure improvements recommended. The existing accesses will operate at acceptable levels of service with the build out of the proposed Whataburger. As with any new development and potential change in traffic patterns, it is recommended that the agency monitor traffic patterns in the area and if necessary, adjust nearby signal timing.



2. PROPOSED DEVELOPMENT

The study area is located in the City of Albuquerque, New Mexico. The proposed development is generally located on the southeast corner of Alameda Boulevard and San Pedro Drive. See **Figure 1** for a vicinity map.

The proposed Whataburger development is comprised of a 2,999 square foot fast-food restaurant. Additionally, the proposed development will provide two (2) vehicle queuing lanes for the drive-through.

See **Figure 2** and **Appendix A** for the proposed site plan.



FIGURE 1 | VICINITY MAP

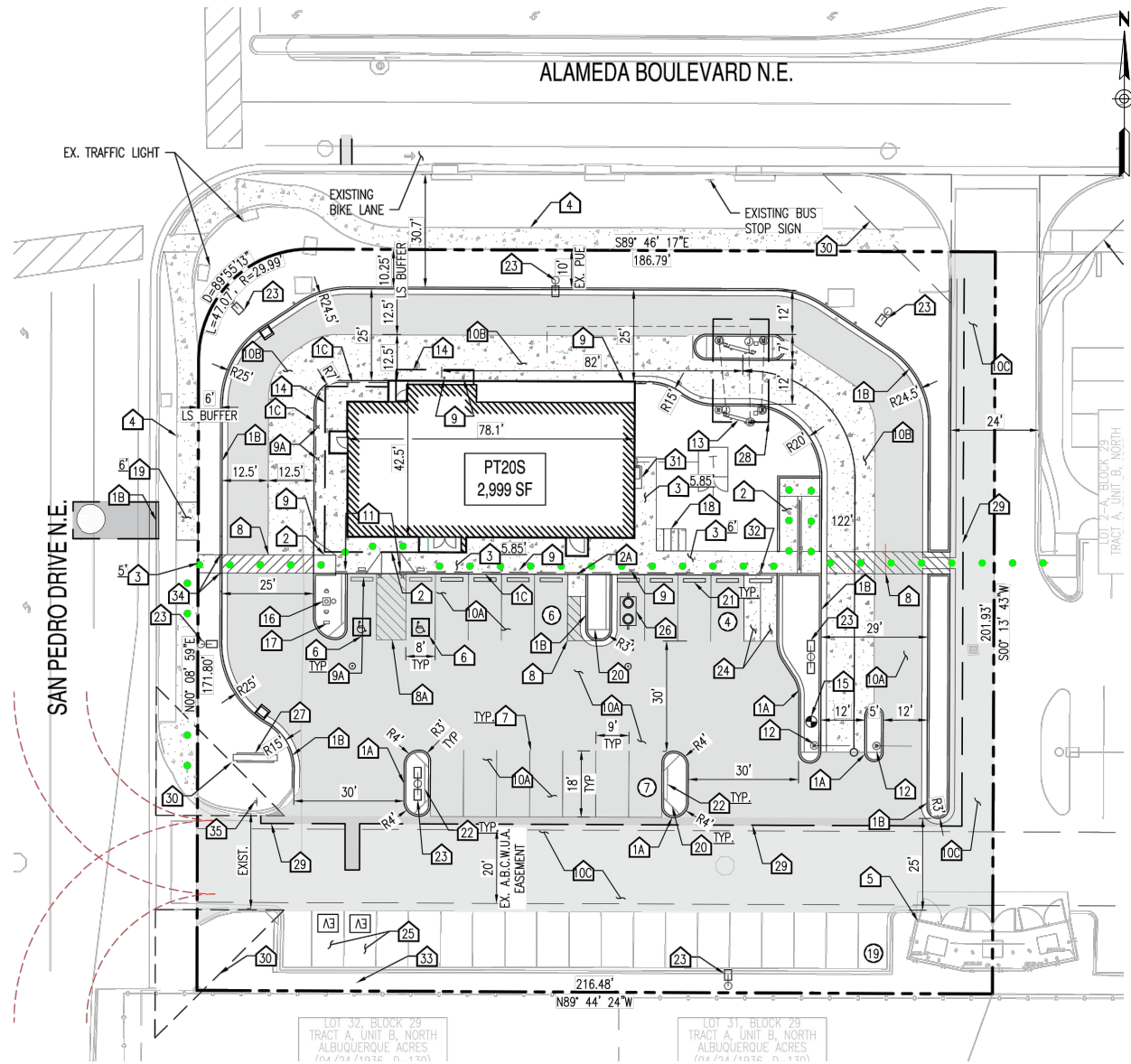

FIGURE 2 | SITE PLAN



3. AREA CONDITIONS

The study area is located in the City of Albuquerque, New Mexico. **Sections 3.1** and **3.2** provide detailed descriptions of the existing study roadway segments and intersections. See **Figure 3** for the study area.

3.1. STUDY ROADWAY SEGMENTS

Alameda Boulevard is an east-west roadway that generally provides two (2) travel lanes in each direction of travel with a raised landscaped median to the east of San Pedro Drive. There is an approximate one-quarter mile segment that currently provides one (1) lane in the eastbound direction of travel, located approximately 850 feet east of San Pedro Drive. Between San Pedro Drive and the Interstate 25 (I-25), Alameda Boulevard provides three (3) lanes for each direction of travel. According to the City of Albuquerque’s online GIS mapping tool, Alameda Boulevard is classified as an urban major collector. There is a posted speed limit of 35 miles per hour (mph).

San Pedro Drive is a north-south roadway that generally provides one (1) lane in each direction of travel south of Alameda Boulevard (to Camel Avenue). North of Alameda Boulevard, San Pedro Drive generally provides one (1) lane in each direction of travel, with the exception of an approximate 500-foot segment that generally provides two (2) lanes in each direction of travel, just north of Alameda Boulevard. According to the City of Albuquerque’s online GIS mapping tool, San Pedro Drive is classified as an urban major collector. There is a posted speed limit of 35 mph.

Signal Avenue is an east-west roadway that generally provides one (1) lane in each direction of travel. According to the City of Albuquerque’s online GIS mapping tool, Signal Avenue is classified as a local urban street. There is a posted speed limit of 25 mph.

3.2. STUDY INTERSECTIONS

Alameda Boulevard and San Pedro Drive (1) currently operates as a signalized intersection. The northbound, southbound, and westbound approaches each provide one (1) dedicated left turn lane, one (1) through lane, and one (1) dedicated right turn lane. The eastbound approach provides one (1) dedicated left turn lane, two (2) through lanes, and one (1) dedicated right turn lane.

Alameda Boulevard and Driveway A (2) currently operates as a one-way stop-controlled T-intersection, with the stop control on the northbound approach. Driveway A is located approximately 260-feet east of San Pedro Drive. The eastbound approach provides one (1) through lane and one (1) shared through-right turn lane. The westbound approach provides two (2) through lanes. The northbound currently provides one (1) dedicated right turn lane.

Alameda Boulevard and Driveway B (3) currently operates as a one-way stop-controlled T-intersection, with the stop control on the southbound approach. Driveway B is located



approximately 440-feet east of San Pedro Drive. The eastbound approach provides one (1) dedicated left turn lane and two (2) through lanes. The westbound approach provides two (2) through lanes and one (1) dedicated right turn lane. The southbound currently provides one (1) shared left-right turn lane.

San Pedro Drive and Driveway C (4) currently operates as a one-way stop-controlled T-intersection, with the stop control on the westbound approach. Driveway C is located approximately 230-feet south of Alameda Boulevard. The northbound approach provides one (1) through lane and one (1) shared through-right turn lane. The southbound approach provides two (2) through lanes. The westbound currently provides one (1) dedicated right turn lane.

San Pedro Drive and Signal Avenue (5) currently operates as a two-way stop-controlled intersection, with the stop control on the eastbound and westbound approaches. The northbound, eastbound, and westbound approaches each provide one (1) shared left-through-right turn lane. The southbound approach provides one (1) shared left-through lane and one (1) dedicated right turn lane.

3.3. STUDY AREA LAND USE

The surrounding area is generally occupied by commercial, industrial, and residential land uses. Tin Can Alley and Stone Age Climbing Gym are located immediately east of the proposed site, and within the shared parking lot. Empire Engines, Inc., is located directly to the south. Additionally, Meineke Car Care Center is located to the west, across San Pedro Drive. The Reserve by Markana residential development is located to the north, across Alameda Boulevard.



3.4. SITE ACCESSIBILITY

Roadway System

The study area is located in the City of Albuquerque, New Mexico. Interstate 25 (I-25) is located approximately 800 feet west of the proposed development. Additionally, Paseo Del Norte Boulevard is located approximately three-quarters of a mile to the south of the proposed development. Within the vicinity of the site there are there is a generally well-developed roadway network which provide continuous east-west and north-south connectivity.

Pedestrian Facilities

The existing frontage adjacent to the proposed site, currently provides detached sidewalks.

Alameda Boulevard generally provides sidewalks within the study area, with the exception of an approximate one-third mile segment on the south side of Alameda Boulevard, located approximately 850 feet east of San Pedro Drive.

San Pedro Drive provides approximately 450-feet of sidewalk on the west side of the roadway and approximately 150-feet on the east side of the roadway, south of Alameda Boulevard.

Bicycle Facilities

Existing bike lanes are provided in both directions of travel along Alameda Boulevard, within the study area.

Transit Facilities

Bus Route 98 currently operates along Alameda Boulevard, within the study area. Two (2) bus stops are provided near the intersection of Alameda Boulevard and San Pedro Drive (1), one (1) for the eastbound and one (1) for the westbound direction of travel.

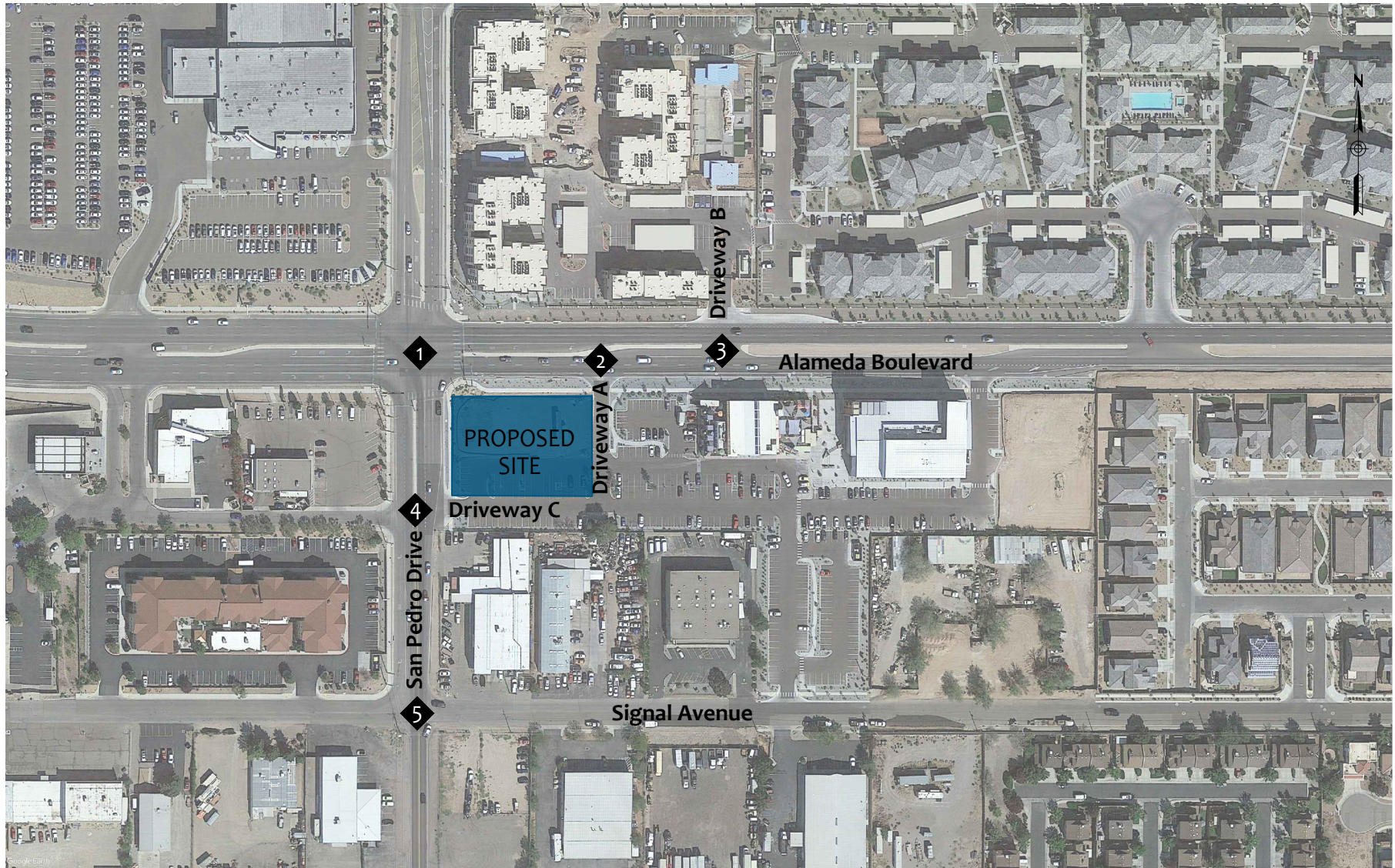

Legend



Intersection

FIGURE 3 | STUDY AREA



4. EXISTING CONDITIONS

4.1. EXISTING LAND USE

According to the City of Albuquerque’s online zoning map online tool, the proposed site is currently zoned for Non-Residential Business Park (NR-BP) land uses. The NR-BP is intended to accommodate a wide range of nonresidential land uses, including, but not limited to, office, commercial, light industrial and institutional land uses. See **Appendix B** for detailed parcel information.

4.2. EXISTING TRAFFIC COUNTS

A data collection firm, All Traffic Data Services, was utilized to collect traffic counts. On Tuesday, December 14, 2021, 4 hours of typical weekday turning movements were counted during the AM (7:00 to 9:00 am) and PM (4:00 to 6:00 pm) peak hours at the following intersections:

- Alameda Boulevard and San Pedro Drive (1)
- Alameda Boulevard and Driveway A (2)
- Alameda Boulevard and Driveway B (3)
- San Pedro Drive and Driveway C (4)
- San Pedro Drive and Signal Avenue (5)

The turning movement counts were then analyzed for the highest 1-hour within each time period. The following peak hours were analyzed throughout this study.

AM Peak Hour	7:15 am – 8:15 am
PM Peak Hour	4:15 pm – 5:15 pm

On Tuesday, December 14, 2021, typical weekday bi-directional tube counts for 24-hours in 15-minute intervals were collected along the following roadway segment:

- Alameda Boulevard, east of San Pedro Drive
- San Pedro Drive, south of Alameda Boulevard

The recorded counts at San Pedro Drive and Driveway C (4) indicate that vehicles were recorded performing the westbound left turn movement. There is currently a raised median that extends to the south of this driveway that is intended to prohibit this movement. These movements are shown throughout this report as existing movements.

See **Appendix C** for detailed traffic count data. See **Figure 4** for the existing weekday AM and PM peak hour traffic volumes.

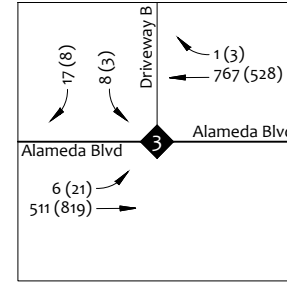
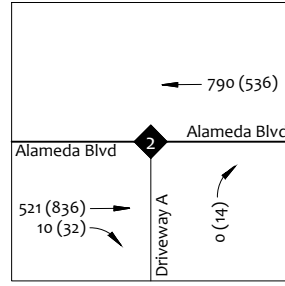
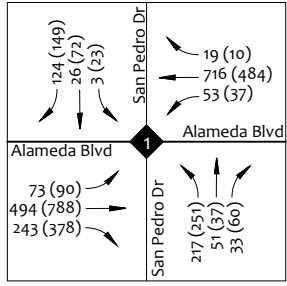

Legend

AM(PM) Peak Hour Traffic Volumes

◆ Intersection

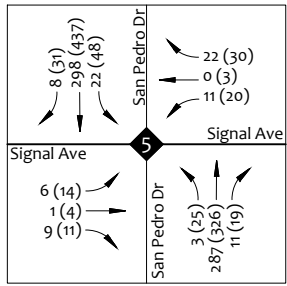
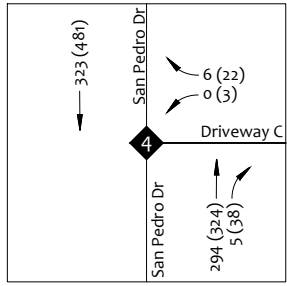

FIGURE 4 | EXISTING TRAFFIC VOLUMES



4.3. EXISTING CAPACITY ANALYSIS

The existing conditions capacity analysis was completed for the existing study intersections. The capacity and level of service for the study area intersections, were evaluated using the methodology presented in the 6th Edition of the Highway Capacity Manual (HCM). Traffic analysis software, Synchro Version 11, was used to perform the analyses using the existing Peak Hour Factor (PHF) obtained from the traffic counts. Existing traffic signal timing for Alameda Boulevard and San Pedro Drive (1) was assumed to operate with a 90-second cycle length and an 8-phase (NEMA) operation. The signal timing splits were optimized.

Table 1 is from the 6th Edition of the Highway Capacity Manual Exhibit 19-8 and 20-2, which lists the Level of Service (LOS) thresholds for signalized and two-way stop-controlled intersections.

Table 1 – Level of Service Criteria

Level of Service	Control Delay per Vehicle (s/veh)	
	Signalized Intersections	Unsignalized Intersections
A	≤ 10	0 - 10
B	> 10-20	> 10-15
C	> 20-35	> 15-25
D	> 35-55	> 25-35
E	> 55-80	> 35-50
F	> 80	> 50

The results of the existing capacity analysis reveal that all locations operate at an existing level of service (LOS) D or better.

See **Figure 5** for the existing AM and PM peak hour capacity analysis. The detailed capacity analysis sheets can be found in **Appendix D**.

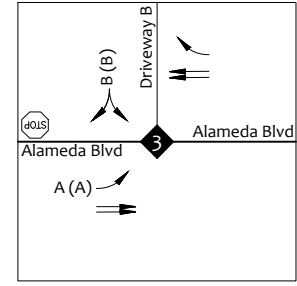
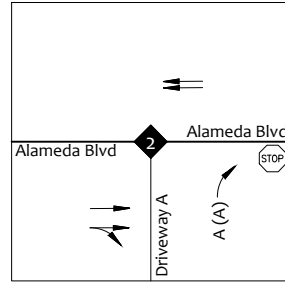
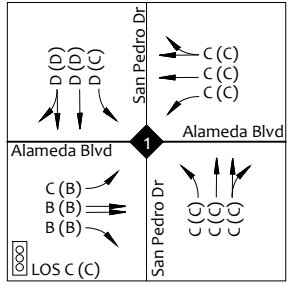

Legend

AM(PM) Peak Hour Capacity Analysis

Intersection

Lane Configuration

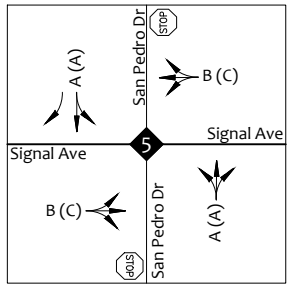
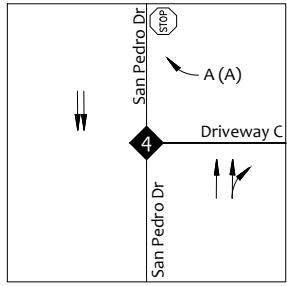

FIGURE 5 | EXISTING CAPACITY ANALYSIS



5. PROJECTED TRAFFIC

5.1. TRIP GENERATION

The trip generation for the proposed development was calculated utilizing the Institute of Transportation Engineers (ITE) publication entitled *Trip Generation, 11th Edition*. The ITE rates are based on studies that measured the trip generation characteristics for various types of land uses. The rates are expressed in terms of trips per unit of land use type. This publication is considered to be the standard for the transportation engineering profession.

As previously mentioned, the proposed Whataburger development is comprised of a 2,999 square foot building, therefore the trip generation for the proposed development was calculated utilizing the ITE Land Use 934 – Fast-Food Restaurant with Drive-Through Window. The total trip generation for the proposed development is shown in **Table 2** below.

Pass-by Trips

Pass-by trips are intermediate stops on the way from an origin to a primary trip destination without a route diversion. Pass-by trips are attracted from the existing traffic passing the site on an adjacent street or roadway that offers direct access to the generator. These trips are not considered to add new traffic to the adjacent street network and may be reduced from the total external trips generated by the proposed development. Pass-by rates were applied to the Weekday, AM Peak Hour and PM Peak Hour trips. These rates are based on data provided in the *Trip Generation Handbook, 3rd Edition*.

Table 2 – Trip Generation (Proposed Development)

Land Use	ITE Code	Qty	Unit	Weekday	AM Peak Hour			PM Peak Hour		
				Total	Total	In	Out	Total	In	Out
Fast-Food Restaurant with Drive-Through Window	934	2,999	1000 SF GFA	1,402	134	68	66	99	51	48
Pass-By Trips				687	66	33	32	50	26	24
Total New Trips				715	68	35	34	50	26	24

The proposed Whataburger development is anticipated to generate 715 weekday trips, with 68 trips occurring during the AM peak hour and 50 occurring during the PM peak hour.

Detailed trip generation calculations are provided in **Appendix E**.



5.2. TRIP GENERATION COMPARISON

Previously Approved Land Use

The previously approved development site plan indicated this location was anticipated to be a 3,000 square foot restaurant. See **Appendix F**.

Utilizing ITE Land Use 932 – High-Turnover (Sit-Down) Restaurant for the previously approved site, the trip generation for the existing zoning was calculated as shown in **Table 3** below.

Table 3 – Trip Generation (Previously Approved)

Land Use	ITE Code	Qty	Unit	Weekday	AM Peak Hour			PM Peak Hour		
				Total	Total	In	Out	Total	In	Out
High-Turnover (Sit-Down) Restaurant	932	3,000	1000 SF GFA	322	29	16	13	27	16	11

Proposed Land Uses versus Previously Approved Land Use

A trip generation comparison was calculated between the proposed Whataburger development and the previously approved restaurant land use was calculated and is shown in **Table 4** below.

Table 4 – Trip Generation Comparison

Land Use	ITE Code	Qty	Unit	Weekday	AM Peak Hour			PM Peak Hour		
				Total	Total	In	Out	Total	In	Out
Fast-Food Restaurant with Drive-Through Window	934	2,999	1000 SF GFA	1,402	134	68	66	99	51	48
Pass-By Trips				687	66	33	32	50	26	24
Proposed Site New Trips				715	68	35	34	50	26	24
High-Turnover (Sit-Down) Restaurant	932	3,000	1000 SF GFA	322	29	16	13	27	16	11
Previously Approved Site Trips				322	29	16	13	27	16	11
Difference				393	39	19	21	23	10	13

The build-out of the Whataburger development is anticipated to generate 393 (55%) more weekday trips, with 39 (58%) more trips during the AM peak hour, and 23 (45%) more trips during the PM peak hour than build out of the previously approved 3,000 square foot restaurant.



5.3. TRIP DISTRIBUTION AND ASSIGNMENT

The trip distribution procedure determines the general pattern of travel for vehicles entering and exiting the proposed development. The trip distribution for the proposed Whataburger development is based on the surrounding roadway network, permitted movements at the proposed site driveways, and probable routes. The trip distribution is shown in **Figure 6**.

The trip assignment was generally based on proximity of the driveways, permitted turn movements, as well as ease and probability of use. The site generated traffic volumes for the proposed Whataburger development are shown in **Figure 7**. Pass-by traffic volumes are shown in **Figure 8**.

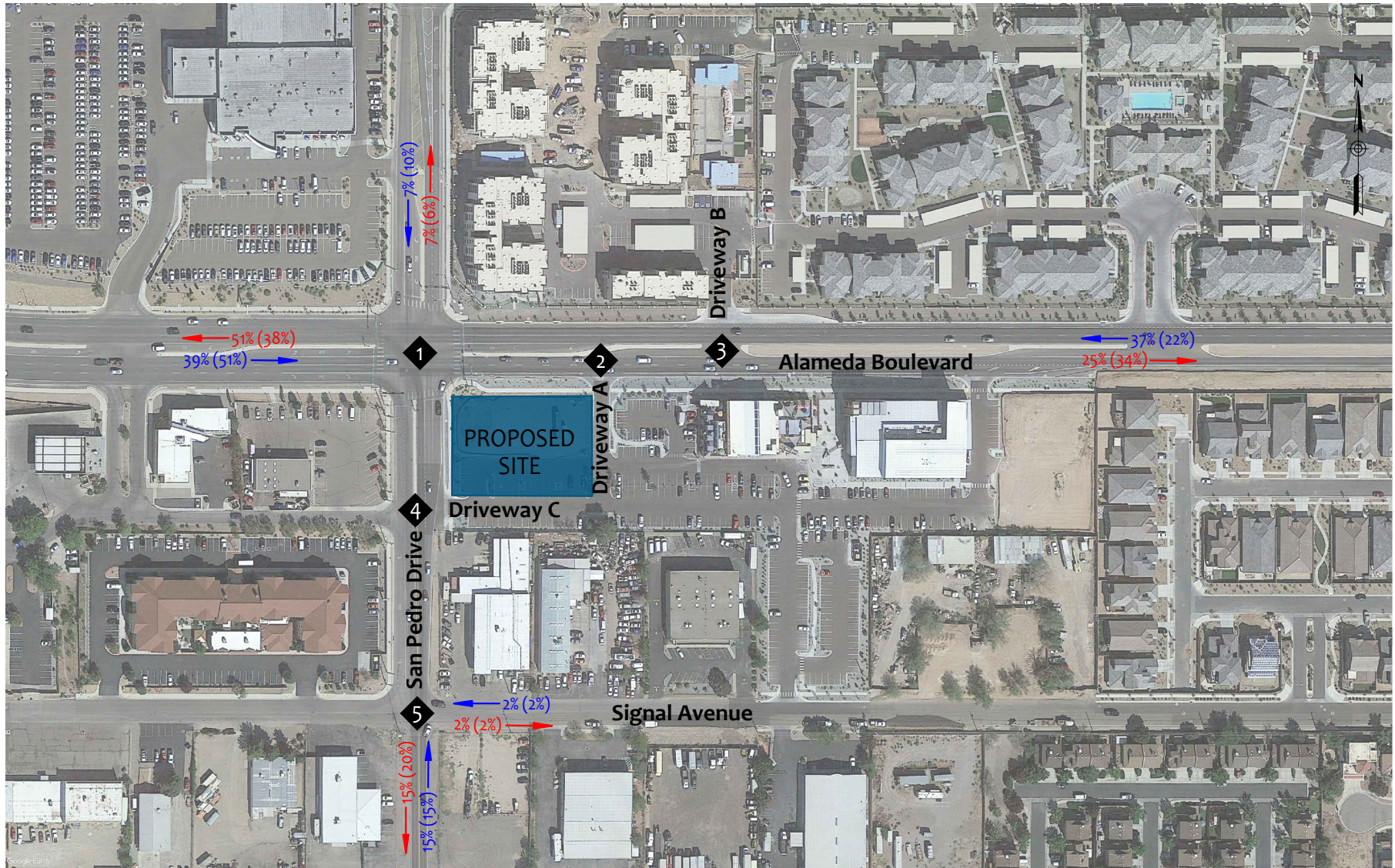

Legend

AM(PM) Trip Distribution Percentages

FIGURE 6 | TRIP DISTRIBUTION

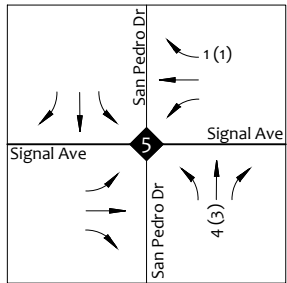
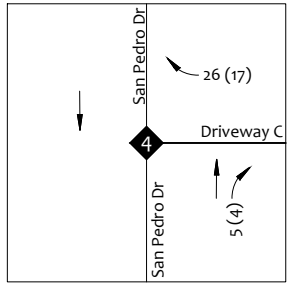
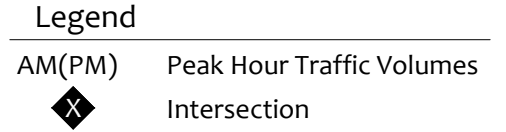
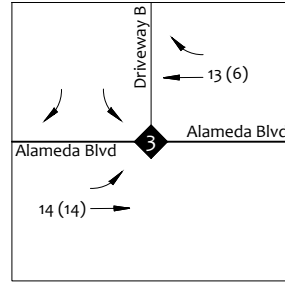
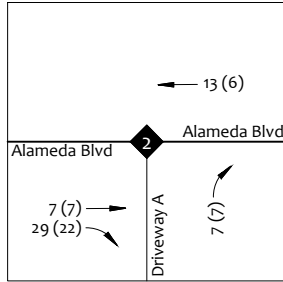
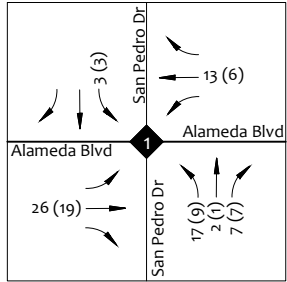
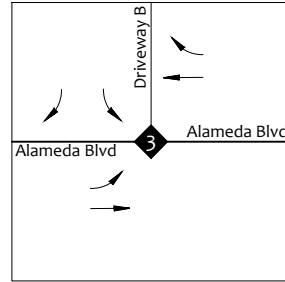
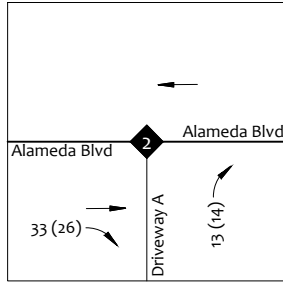
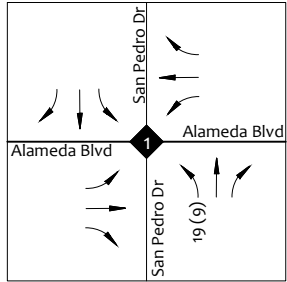

FIGURE 7 | SITE TRAFFIC VOLUMES



Legend
AM(PM) Peak Hour Traffic Volumes
◆ Intersection

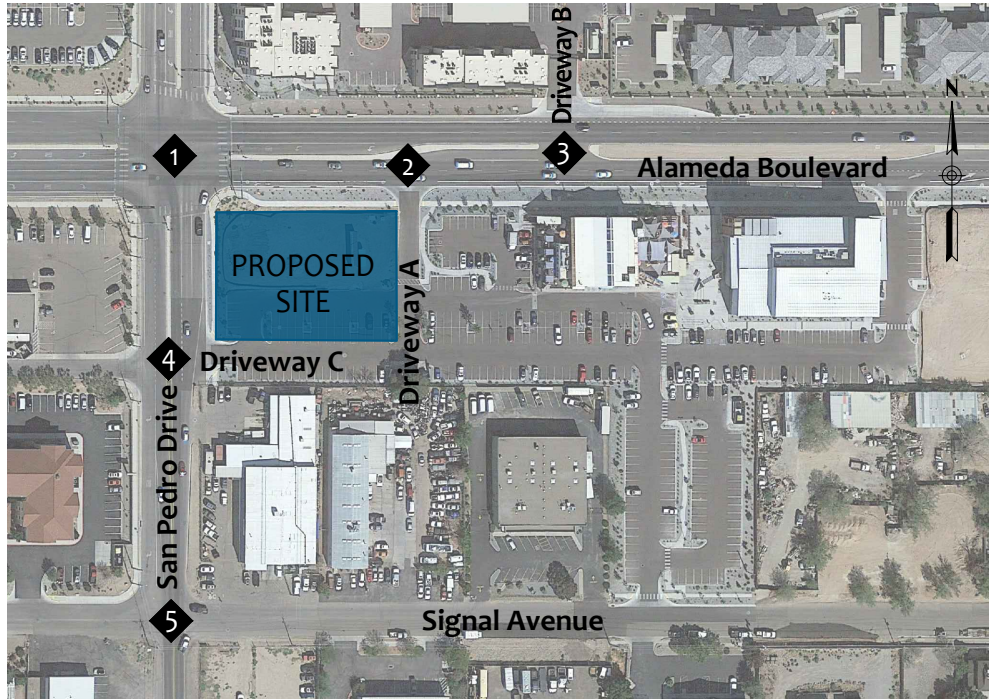
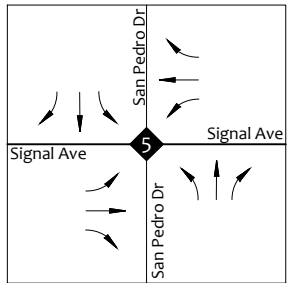
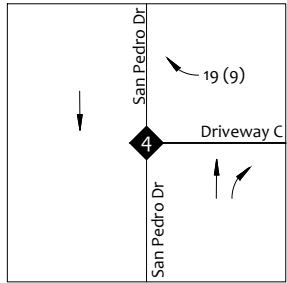

FIGURE 8 | PASS-BY TRAFFIC VOLUMES



6. FUTURE CONDITIONS (YEAR 2022 – OPENING YEAR)

The Whataburger development is anticipated to be open in the year 2022. This section analyzes the effects the proposed development will have on the surrounding roadway network in the year 2022.

6.1. YEAR 2022 BACKGROUND TRAFFIC VOLUMES

According to the United States Census Bureau online tool, in the year 2010, the City of Albuquerque had an estimated population of approximately 545,852. Similarly, the United States Census Bureau online tool estimated the year 2020 population to be approximately 564,559. This results in an approximate annual growth rate of 0.34%.

As a conservative approach, a 1.0% annual growth rate was utilized. See [Appendix G](#) for the United States Census Bureau data.

The year 2022 background traffic volumes are shown in [Figure 9](#).

6.2. YEAR 2022 BUILD TRAFFIC VOLUMES

To determine the year 2022 build traffic volumes, the site traffic volumes ([Figure 7](#)) were added to the pass-by traffic volumes ([Figure 8](#)) and the year 2022 background traffic volumes ([Figure 9](#)). This represents year 2022 traffic volumes with the build out of the proposed Whataburger development. The year 2022 build traffic volumes are shown in [Figure 10](#).

6.3. YEAR 2022 BUILD CAPACITY ANALYSIS

The year 2022 build capacity analysis was completed for the five (5) study intersections during the AM and PM peak hour. The capacity analysis for the study area intersections were evaluated using the methodology described in [Section 4.3](#). The corresponding traffic volumes are shown in [Figure 10](#). The PHF was assumed to be 0.92 for all study intersections.

The results of the 2022 build capacity analysis level of service are shown in [Figure 11](#). All movements operate at a LOS D or better during the AM and PM peak hours.

The detailed capacity analysis sheets can be found in [Appendix H](#).

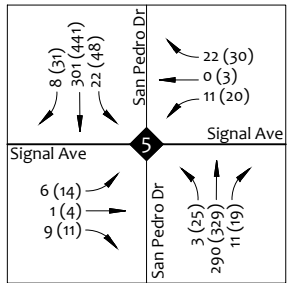
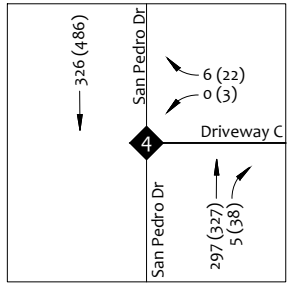
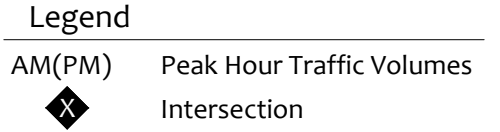
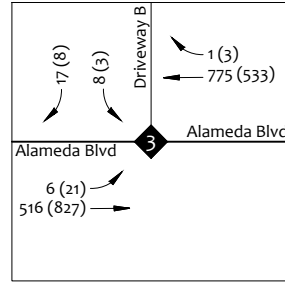
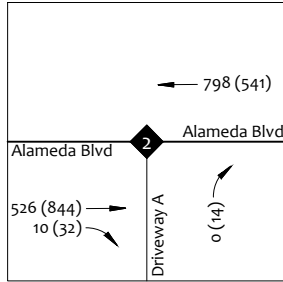
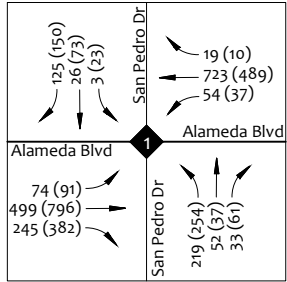
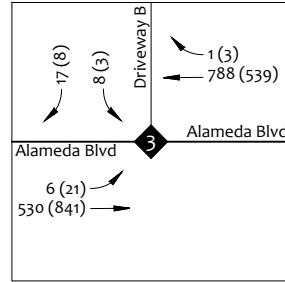
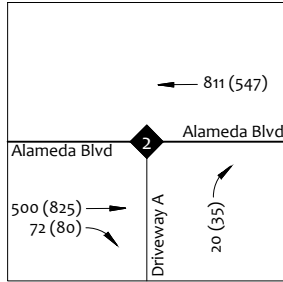
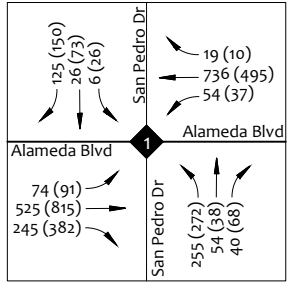

FIGURE 9 | YEAR 2022 BACKGROUND TRAFFIC VOLUMES



Legend
 AM(PM) Peak Hour Traffic Volumes
 X Intersection

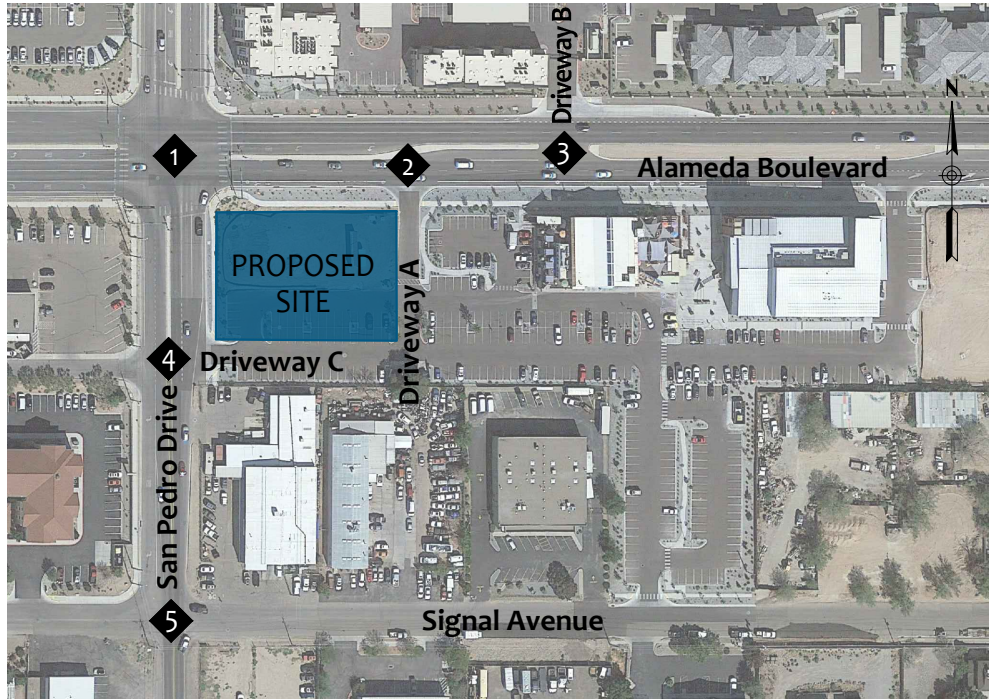
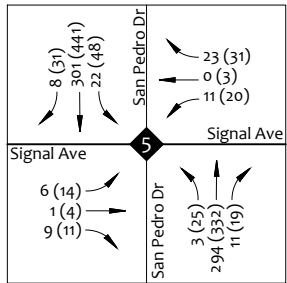
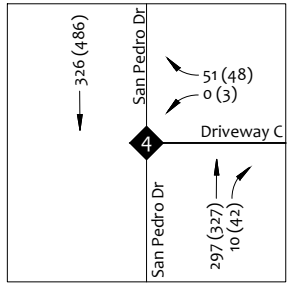
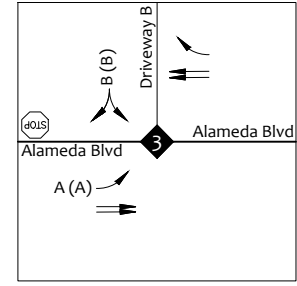
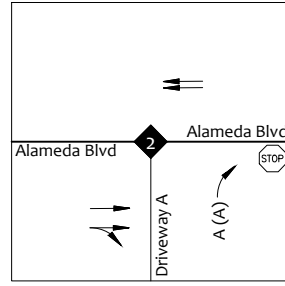
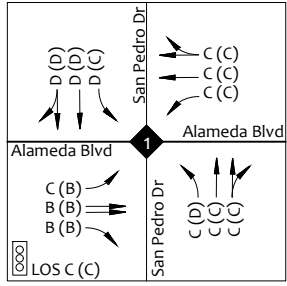

FIGURE 10 | YEAR 2022 BUILD TRAFFIC VOLUMES



Legend

AM(PM) Peak Hour Capacity Analysis

Intersection

Lane Configuration

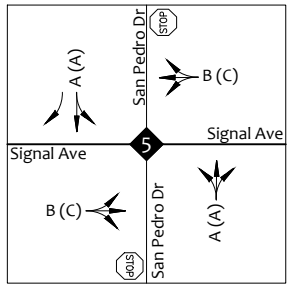
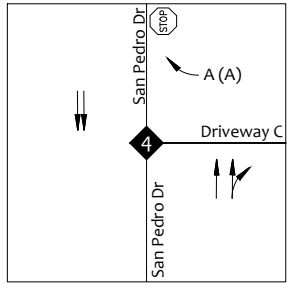

FIGURE 11 | YEAR 2022 BUILD CAPACITY ANALYSIS



7. ON-SITE CIRCULATION AND QUEUE

The proposed Whataburger provides two (2) queuing lanes that circle the building in a counterclockwise manner. A menu board will be provided for each lane along paired with a station for placing orders. After placing the order, drivers will proceed to the pick-up location. It is anticipated that an employee will take payment and deliver food to both queuing lanes. This operation is anticipated to occur during peak business hours.

The two (2) queue lanes provide approximately 460 feet of storage length. Conservatively assuming 25 feet per vehicle, this length equates 18 vehicles of storage to the pick-up window. See **Figure 12** for on-site queuing exhibit.

During the AM and PM peak hours, the proposed Whataburger is anticipated to generate 134 and 99 peak hour trips, respectively. Of these, 68 and 51 trips will be entering the site during the AM and PM peak hour, respectively. This approximately equates to one (1) vehicle entering each minute. With a queue capacity of 18 vehicles, assuming consistent arrivals, this would be the equivalent of 18 minutes of queuing.

Furthermore, the proposed Whataburger provides indoor seating and 36 parking stalls. Therefore, it is expected that a portion of the 68 AM and 51 PM peak hour inbound trips will not enter the drive-through.

This site and drive-through queue lengths have been designed consistently with other Whataburger locations and is based on the successful on-site circulation and processing of drive-through queuing.

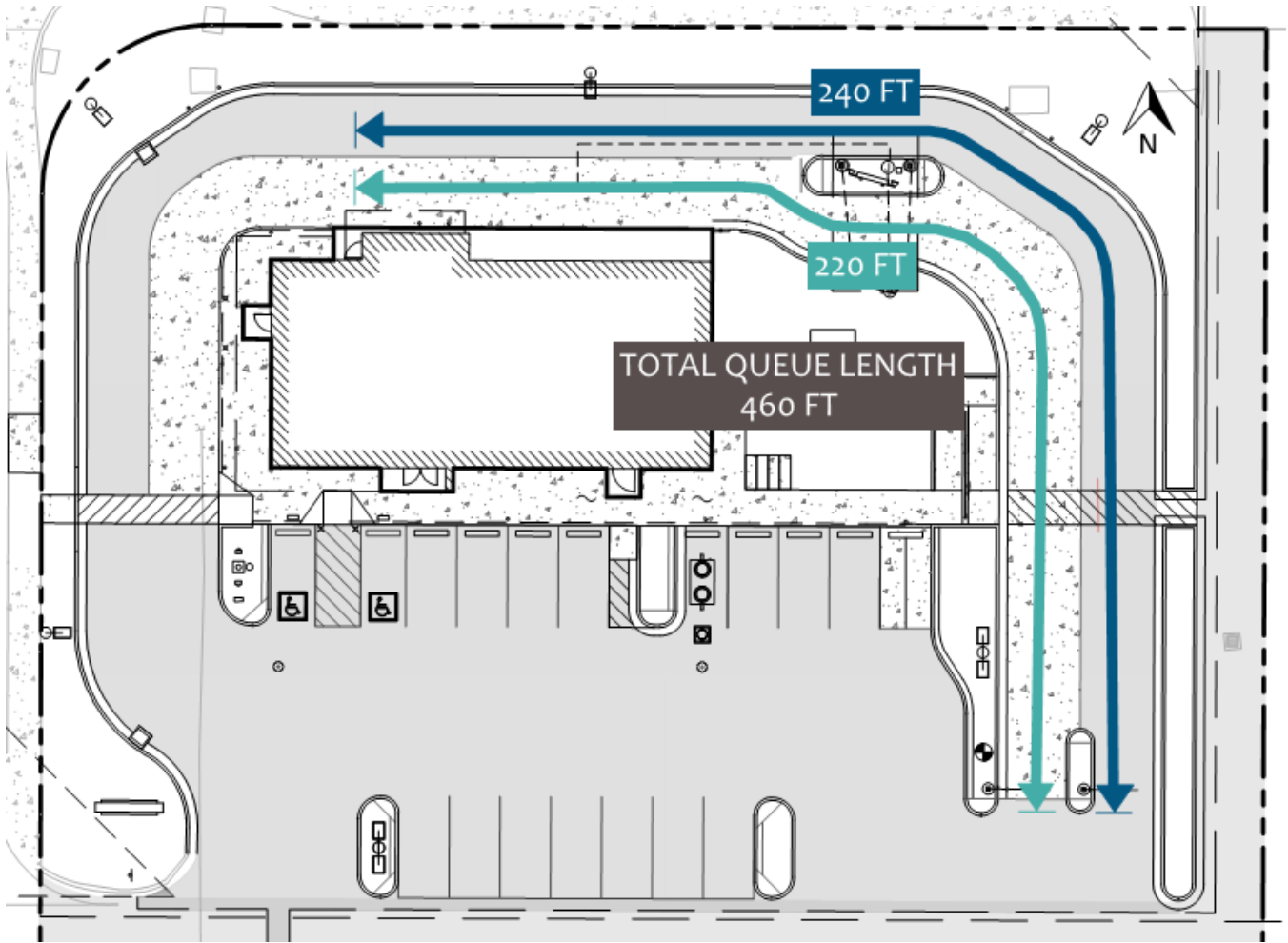

Figure 12 – On-Site Queue



8. RECOMMENDATIONS & CONCLUSIONS

Beyond the build out of the proposed Whataburger site with two (2) vehicle queuing lanes for the drive-through, there are no other transportation infrastructure improvements recommended. The existing accesses will operate at acceptable levels of service with the build out of the proposed Whataburger. As with any new development and potential change in traffic patterns, it is recommended that the agency monitor traffic patterns in the area and if necessary, adjust nearby signal timing.



Appendix A – Proposed Site Plan

DEVELOPER
 WHATABURGERS REAL ESTATE
 CONTACT: CINDY ESPINOZA
 300 CONCORD PLAZA DRIVE
 SAN ANTONIO, TX 78216
 PHONE: 210-476-6180
 EMAIL: CESPINOZA@WBHQ.COM

CIVIL ENGINEER
 SUSTAINABILITY ENGINEERING GROUP
 8280 E. GELDING DR, SUITE 101
 SCOTTSDALE, ARIZONA 85260
 PHONE: 480-237-2507
 ATTN: ALI FAKIH

OWNER
 GREEN JEANS WEST, LLC
 2929 MONTE VISTA BLVD NE
 ALBUQUERQUE, NM 87106

WHATABURGER

PRELIMINARY SITE PLAN

6100 ALAMEDA NE BLVD, ALBUQUERQUE, NM
 LOT 1-A, BLOCK 29, TRACT A, UNIT B OF NORTH
 BERNALILLO COUNTY, NEW MEXICO.

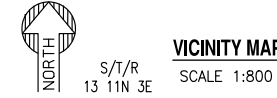
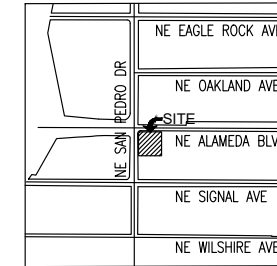

NOT FOR
CONSTRUCTION

SUSTAINABILITY
ENGINEERING
GROUP

SEG



CALL NM ONE-CALL
SYSTEM SEVEN (7) DAYS
PRIOR TO ANY EXCAVATION

PROJECT LOCATION
 WHATABURGER NM
 SEC ALAMEDA BLVD NE
 & SAN PEDRO AVE NE
 6100 ALAMEDA BLVD NE
 ALBUQUERQUE, NM

DATE: 01/21/2022
 ISSUED FOR: DRB

REVISION NO.: DATE:
 1 12/08/2021
 2 01/12/2022
 3 01/18/2022

JOB NO.: 210907
 SHEET TITLE: PRELIMINARY SITE PLAN

PAGE NO.: 1 of 2
 SHEET NO.: C2.00

LOCATION: Z:\SHARED\PROJECTS\WHATABURGER\ALBUQUERQUE, NM - SWC ALAMEDA BLVD & SAN PEDRO AVE - 210907\11 CAD (SEG)\11.4 CD\CD210907-C2.00.DWG SAVED BY: ESAUL REYES DATE: 1/21/2022

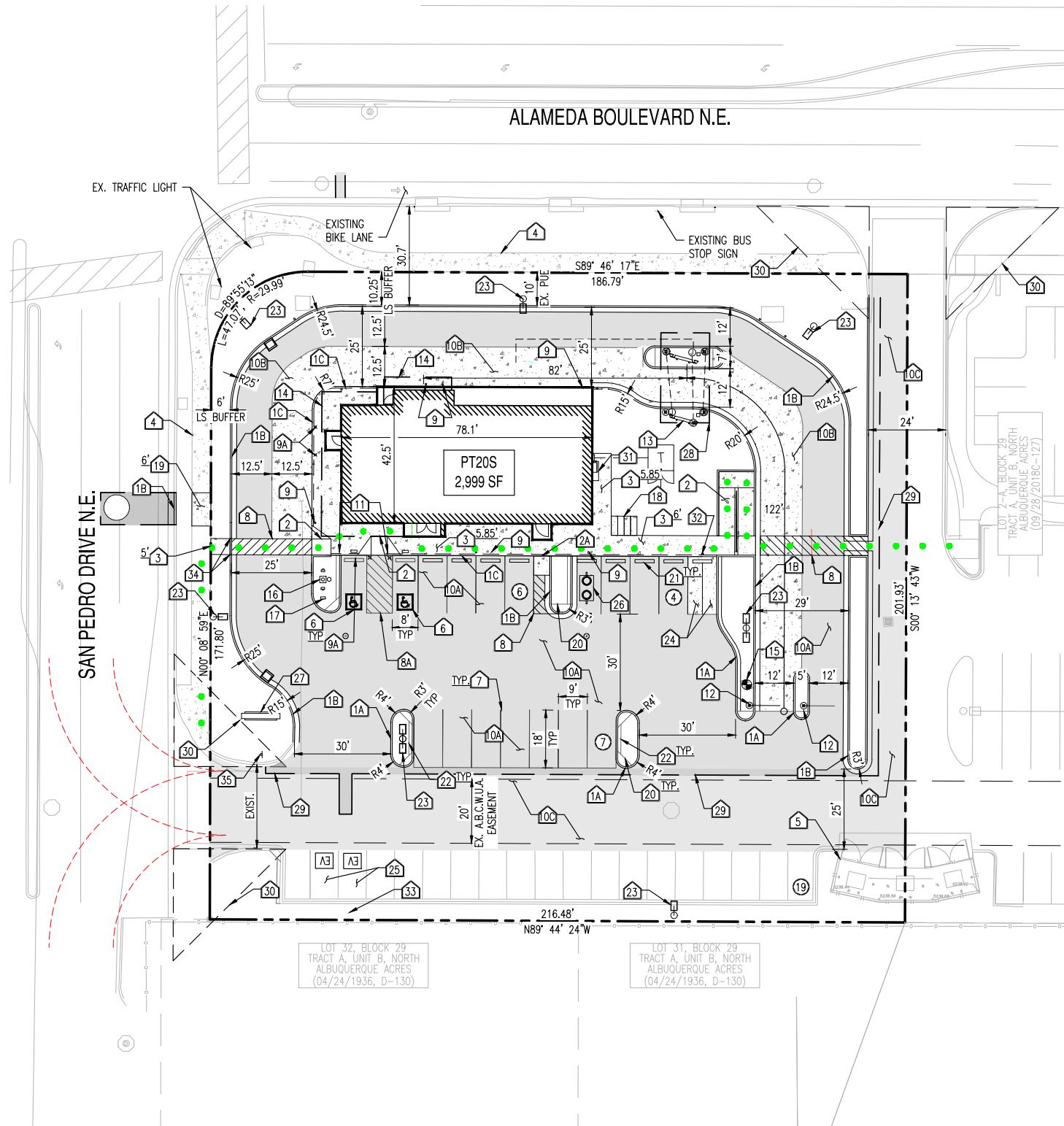

PRELIMINARY SITE PLAN KEYNOTES:

- 1A 6" VERTICAL CURB PER GRADING PLANS.
- 1B 6" CURB AND GUTTER PER GRADING PLANS.
- 1C TURNDOWN SIDEWALK PER GRADING PLANS.
- 2 ACCESSIBLE RAMP PER GRADING PLANS.
- 2A ACCESSIBLE RAMP PER GRADING PLANS.
- 3 CONCRETE SIDEWALK, WIDTH PER PLAN.
- 4 EXISTING SIDEWALK TO REMAIN.
- 5 EXISTING TRASH ENCLOSURE.
- 6 PAINTED ADA SYMBOL PER DET. 1/C2.10.
- 7 4" WIDE WHITE PAINTED STRIPING, TYP.
- 8 5' WIDE PEDESTRIAN PATHWAY WITH 4" WIDE YELLOW PAINT, AT 45' 2 FEET O.C.
- 8A 8' WIDE PEDESTRIAN PATHWAY AT ACCESSIBLE PARKING WITH 4" WIDE YELLOW PAINT, AT 45' 2 FEET O.C.
- 9 6" STEEL BOLLARDS PER DET. 3/C2.10.
- 9A 6" LIT STEEL BOLLARDS PER DET. 3/C2.10.
- 10A HEAVY DUTY ASPHALT PAVEMENT PER CIVIL PLANS.
- 10B HEAVY DUTY CONCRETE PAVEMENT PER GRADING PLANS.
- 10C EXISTING ASPHALT.
- 11 ACCESSIBLE PARKING SIGN PER DET. 2/C2.10.
- 12 DRIVE-THRU CLEARANCE BAR PER ARCHITECTURAL PLANS.
- 13 INSTALL DRIVE-THRU MENU BOARD. PER DETAIL 6/C2.10.
- 14 PROVIDE 4' RESTAURANT CANOPY PER ARCHITECTURAL PLANS.
- 15 RELOCATED FIRE HYDRANT LOCATION.
- 16 INSTALL 28" HIGH FLAG POLE.
- 17 INSTALL FREE STANDING MAILBOX BY G.C.
- 18 INSTALL BIKE RACK (4 SPACES). PER DET. 5/C2.10.
- 19 REMOVE AND REPLACE SIDEWALK. WIDTH PER PLAN.
- 20 CONSTRUCT CONCRETE ISLANDS NOSE, TYPICAL AT ISLANDS.
- 21 WHEEL STOP PER DET. 4/C2.10.
- 22 PROVIDE GRANITE STRIPS.
- 23 INSTALL LIGHT POLE PER PHOTOMETRIC PLAN.
- 24 MOTORCYCLE PARKING (2 SPACES).
- 25 ELECTRIC VEHICLE PARKING (2 SPACES).
- 26 INSTALL GREASE INTERCEPTOR PER UTILITY PLANS.
- 27 PROPOSED MONUMENT SIGN LOCATION.
- 28 INSTALL MENU BOARD CANOPY
- 29 PROVIDE SAWCUT PER CIVIL PLANS.
- 30 SVT 35'X35'.
- 31 ELECTRICAL CABINET.
- 32 MOTORCYCLE PARKING ONLY SIGN.
- 33 FUTURE CHARGING STATION LOCATION.
- 34 CURB TRANSITION FROM TO 0" PER CIVIL PLANS.
- 35 PROPOSED STOP SIGN AT DRIVEWAY.

SITE PLAN NOTES

1. DEVELOPMENT AND USE OF THIS SITE WILL CONFORM TO ALL APPLICABLE CODES AND ORDINANCES.
2. FIRE LANES SHALL BE ESTABLISHED AND PROPERLY DESIGNATED IN ACCORDANCE WITH THE LOCAL MUNICIPALITY AND LOCAL FIRE DEPARTMENT REQUIREMENTS.
3. ALL NEW OR RELOCATED UTILITIES WILL BE PLACED UNDERGROUND.
4. ALL ROOFTOP EQUIPMENT AND SATELLITE DISHES SHALL BE SCREENED TO THE HEIGHT OF THE TALLEST EQUIPMENT.
5. ALL SERVICE AREAS SHALL BE SCREENED TO CONCEAL TRASH CONTAINERS, LOADING DOCKS, TRANSFORMERS, BACKFLOW PREVENTERS AND OTHER MECHANICAL OR ELECTRICAL EQUIPMENT FROM EYE LEVEL ADJACENT TO ALL PUBLIC STREETS.
6. IF APPLICABLE, PEDESTRIAN ACCESS ROUTES ARE PROVIDED IN COMPLIANCE WITH THE LATEST ADA STANDARDS. ALL RAMPS MUST MEET ADA ACCESSIBILITY GUIDELINES (ADAAG) STANDARDS, 2% MAX CROSS SLOPES, AND 5% MAXIMUM LONGITUDINAL SLOPES. TRUNCATED DOMES, AS DETECTABLE WARNINGS, ARE REQUIRED, AS SHOWN IN PLANS, ON ALL SITE RAMPS AND WALKS THAT CROSS A VEHICULAR WAY PER ADAAG CHAPTER 7.
7. PIPE BOLLARDS SHALL BE INSTALLED IN TRAFFIC AND LOADING AREAS AS REQUIRED TO PROTECT BUILDING CORNERS, RECEIVING AREAS, HYDRANTS, TRANSFORMERS, METERS, GENERATORS, COMPACTORS, STEPS, AND RAILINGS, AS NECESSARY.
8. ALL SIGNAGE REQUIRES SEPARATE APPROVAL AND PERMITS.
9. A MINIMUM 6-FOOT HORIZONTAL SEPARATION BETWEEN WATER AND SEWER PIPELINES WILL BE MAINTAINED.
10. OWNERS OF PROPERTY ADJACENT TO THE PUBLIC RIGHT-OF-WAY WILL HAVE THE RESPONSIBILITY FOR MAINTAINING ALL LANDSCAPING WITHIN THE RIGHT-OF-WAY IN ACCORDANCE WITH APPROVED PLANS.

DEVELOPMENT SUMMARY TABLE:

PROJECT ADDRESS:	6100 ALAMEDA BLVD NE, ALBUQUERQUE, NM		
PROJECT DESCRIPTION:	PROPOSED WHATABURGER W/ DRIVE THRU		
UPC:	101806 428134 810229		
ZONING:	NR-BP		
LOT SIZE:	43,565 SF	1.00 AC	
PROPOSED USE:	RESTAURANT W/ DRIVE THROUGH		
BUILDING AREA:	2,999 SF		
MAX BUILDING HEIGHT:	ALLOWED	PROPOSED	
RESTAURANT BUILDING:	50 FT.	22 FT.	
LOT STANDARDS	REQUIRED	PROPOSED	
MIN LOT WIDTH:	100 FT.	± 186 FT.	
PARKING REQUIREMENT	REQUIRED	PROPOSED	
VEHICLE (2,965 SF/1,000 SF x 8):	24		
ADA SPACES:	2	36	INCL. 2 EV SPACES
EV SPACES:	2		2 ADA SPACES
MOTORCYCLE (1 PER 25 SPACES):	2	2	
BICYCLE SPACES:	3	4	
MINIMUM BUILDING SETBACKS	REQUIRED	PROPOSED	
FRONT (ALAMEDA BLVD NE):	10 FT.	± 36 FT.	
SIDE (SAN PEDRO ROAD NE):	10 FT.	± 31 FT.	
REAR (SOUTH SIDE):	10 FT.	± 119.5 FT.	
MINIMUM LANDSCAPE BUFFER	REQUIRED	PROPOSED	
FRONT (ALAMEDA BLVD NE):	10 FT.	± 10 FT.	
SIDE (SAN PEDRO ROAD NE):	6 FT.	± 22 FT.	WHERE PARKING LOTS ADJACENT TO LOT EDGE
REAR (SOUTH SIDE):	6 FT.	± 6 FT.	

PROPOSED LEGEND:

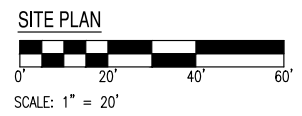
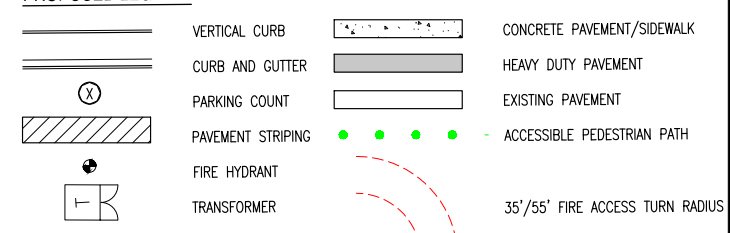

THIS DRAWING IS AN INSTRUMENT OF SERVICE AND THE PROPERTY OF SUSTAINABILITY ENGINEERING GROUP, AND SHALL REMAIN THEIR PROPERTY. THE USE OF THIS DRAWING SHALL BE RESTRICTED TO THE ORIGINAL SITE FOR WHICH IT IS PREPARED AND PUBLICATION THEREOF IS EXPRESSLY LIMITED TO SUCH USE.



Appendix B – Parcel Information



Pan



Zoom In



Zoom Out



Initial View



Previous Extent



Next Extent



Bookmarks



Print



Export



Share

Navigation Tools

Print and Share

Bernalillo County Parcels

I want to...

Description

UPC: 101806428134810229

Owner: GREEN JEANS WEST LLC

Owner Address: 6110 ALAMEDA BLVD NE UNIT 12
ALBUQUERQUE NM 87113-2031

Situs Address: ALAMEDA BLVD NE ALBUQUERQUE
NM 87113

Legal Description: LT 1-A BLK 29 PLAT OF LOTS 1-A,
2-A, 4-A, & 6-A BLOCK 29TRACT A, UNIT B NORTH
ALBUQUERQUE ACRES CONT 1.0001 AC

Acres: 1.0001

Tax Year: 2021

Details

UPC

101806428134810229

Owner

GREEN JEANS WEST LLC

Owner Address

6110 ALAMEDA BLVD NE UNIT 12

Owner Address 2

ALBUQUERQUE NM 87113-2031

SITUS Address

ALAMEDA BLVD NE

SITUSADD2

ALBUQUERQUE NM 87113

Legal Description

LT 1-A BLK 29 PLAT OF LOTS 1-A, 2-A, 4-A, &
6-A BLOCK 29TRACT A, UNIT B NORTH
ALBUQUERQUE ACRES CONT 1.0001 AC

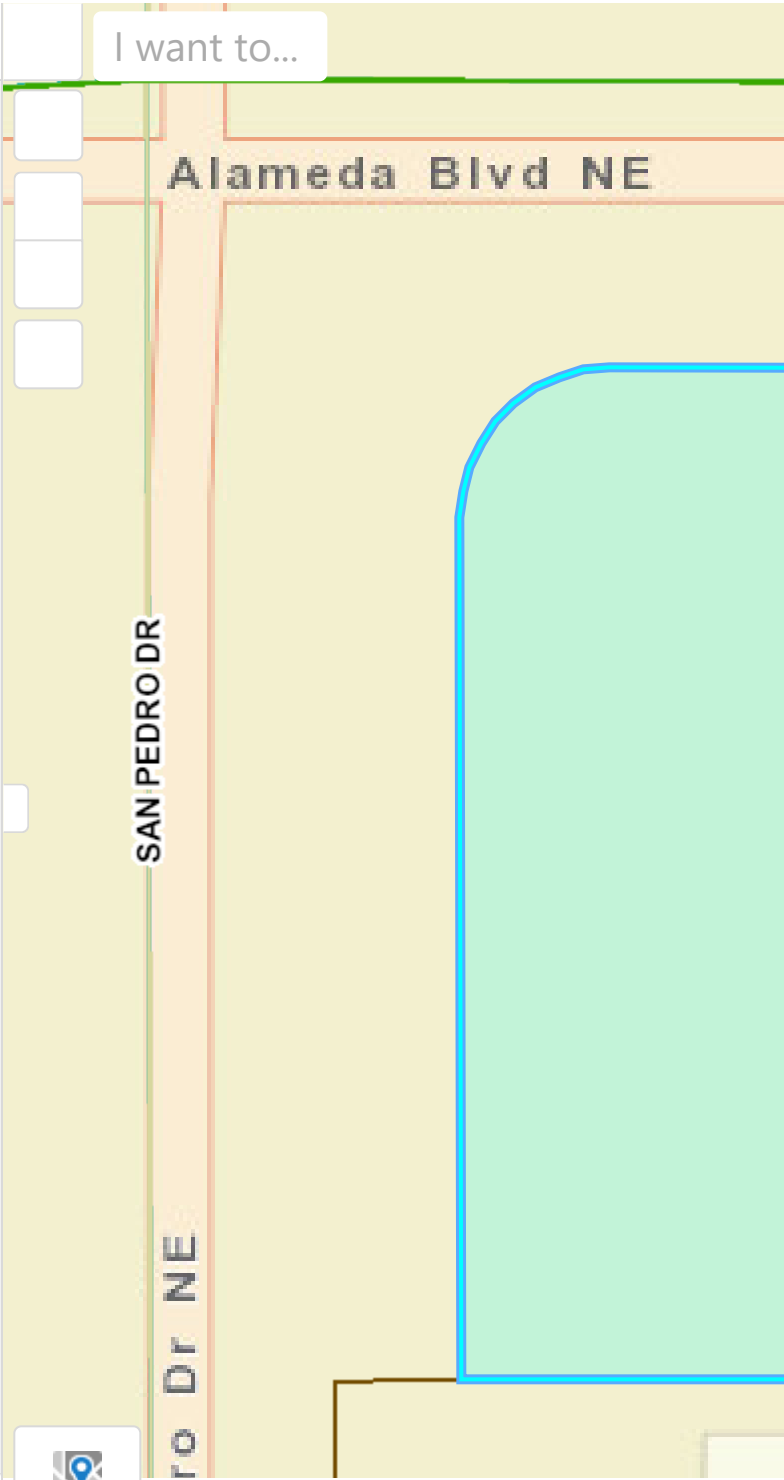

Layers



Bernalillo County Parcels



World St...

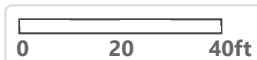



Appendix C – Traffic Count Data



(303) 216-2439
www.alltrafficdata.net

Location: 1 SAN PEDRO DR NE & ALAMEDA BLVD NE AM

Date: Tuesday, December 14, 2021

Peak Hour: 07:15 AM - 08:15 AM

Peak 15-Minutes: 07:45 AM - 08:00 AM

Peak Hour - All Vehicles

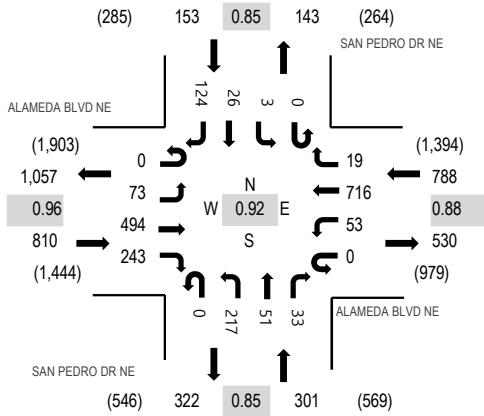

Peak Hour - Pedestrians/Bicycles on Crosswalk

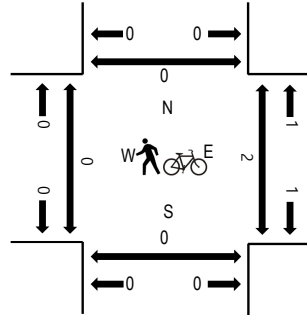

Note: Total study counts contained in parentheses.

Traffic Counts

Interval Start Time	ALAMEDA BLVD NE Eastbound				ALAMEDA BLVD NE Westbound				SAN PEDRO DR NE Northbound				SAN PEDRO DR NE Southbound				Total	Rolling Hour	Pedestrian Crossings			
	U-Turn	Left	Thru	Right	U-Turn	Left	Thru	Right	U-Turn	Left	Thru	Right	U-Turn	Left	Thru	Right			West	East	South	North
7:00 AM	0	19	120	39	0	4	102	2	0	37	5	4	0	1	5	19	357	1,942	0	1	0	0
7:15 AM	0	17	142	50	0	21	193	6	0	26	10	11	0	0	8	37	521	2,052	0	1	0	0
7:30 AM	0	19	103	72	0	11	188	4	0	62	9	6	0	1	7	26	508	1,976	0	0	0	0
7:45 AM	0	18	125	69	0	13	205	6	0	59	13	6	0	1	8	33	556	1,909	0	0	0	0
8:00 AM	0	19	124	52	0	8	130	3	0	70	19	10	0	1	3	28	467	1,750	0	0	0	0
8:15 AM	0	10	93	48	0	10	170	4	0	57	10	14	0	1	6	22	445		0	0	0	0
8:30 AM	0	11	111	45	0	11	141	7	0	51	14	11	0	2	5	32	441		0	0	0	0
8:45 AM	0	22	82	34	0	10	141	4	0	45	13	7	0	3	7	29	397		0	0	0	0
Count Total	0	135	900	409	0	88	1,270	36	0	407	93	69	0	10	49	226	3,692		0	2	0	0
Peak Hour	0	73	494	243	0	53	716	19	0	217	51	33	0	3	26	124	2,052		0	1	0	0



(303) 216-2439
www.alltrafficdata.net

Location: 2 SITE ACCESS & ALAMEDA BLVD NE AM

Date: Tuesday, December 14, 2021

Peak Hour: 07:15 AM - 08:15 AM

Peak 15-Minutes: 07:15 AM - 07:30 AM

Peak Hour - All Vehicles

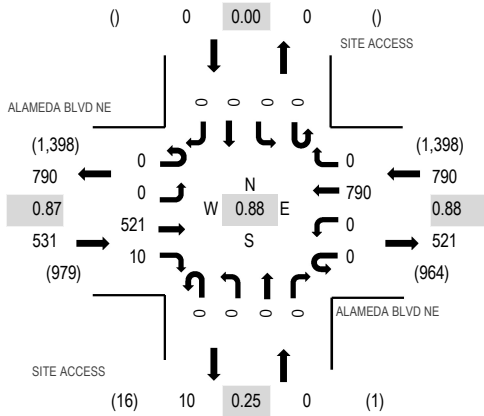

Peak Hour - Pedestrians/Bicycles on Crosswalk

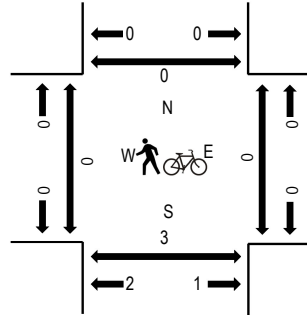

Note: Total study counts contained in parentheses.

Traffic Counts

Interval Start Time	ALAMEDA BLVD NE Eastbound				ALAMEDA BLVD NE Westbound				SITE ACCESS Northbound				SITE ACCESS Southbound				Total	Rolling Hour	Pedestrian Crossings			
	U-Turn	Left	Thru	Right	U-Turn	Left	Thru	Right	U-Turn	Left	Thru	Right	U-Turn	Left	Thru	Right			West	East	South	North
7:00 AM	0	0	126	0	0	0	109	0	0	0	0	0	0	0	0	0	235	1,277	0	0	0	0
7:15 AM	0	0	151	1	0	0	224	0	0	0	0	0	0	0	0	0	376	1,321	0	0	2	0
7:30 AM	0	0	109	4	0	0	201	0	0	0	0	0	0	0	0	0	314	1,235	0	0	0	0
7:45 AM	0	0	129	2	0	0	221	0	0	0	0	0	0	0	0	0	352	1,202	0	0	0	0
8:00 AM	0	0	132	3	0	0	144	0	0	0	0	0	0	0	0	0	279	1,101	0	0	1	0
8:15 AM	0	0	104	2	0	0	184	0	0	0	0	0	0	0	0	0	290		0	0	1	0
8:30 AM	0	0	121	2	0	0	158	0	0	0	0	0	0	0	0	0	281		0	0	0	0
8:45 AM	0	0	91	2	0	0	157	0	0	0	0	1	0	0	0	0	251		0	0	0	0
Count Total	0	0	963	16	0	0	1,398	0	0	0	0	1	0	0	0	0	2,378		0	0	4	0
Peak Hour	0	0	521	10	0	0	790	0	0	0	0	0	0	0	0	0	1,321		0	0	3	0



(303) 216-2439
www.alltrafficdata.net

Location: 3 RESERVE APT ACCESS & ALAMEDA BLVD NE AM

Date: Tuesday, December 14, 2021

Peak Hour: 07:15 AM - 08:15 AM

Peak 15-Minutes: 07:15 AM - 07:30 AM

Peak Hour - All Vehicles

Peak Hour - Pedestrians/Bicycles on Crosswalk

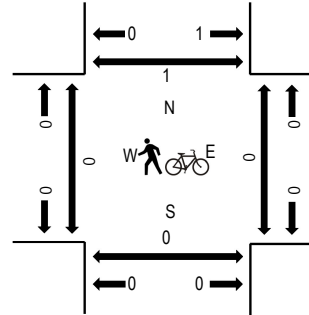
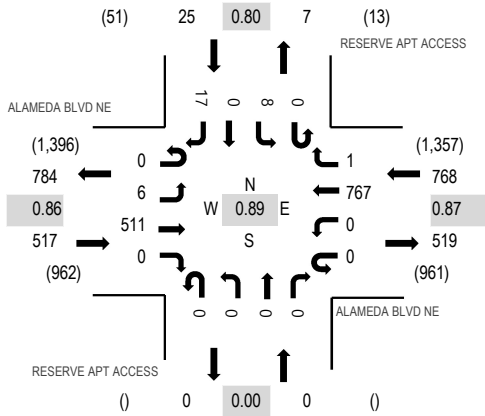

Note: Total study counts contained in parentheses.

Traffic Counts

Interval Start Time	ALAMEDA BLVD NE Eastbound				ALAMEDA BLVD NE Westbound				RESERVE APT ACCESS Northbound				RESERVE APT ACCESS Southbound				Total	Rolling Hour	Pedestrian Crossings			
	U-Turn	Left	Thru	Right	U-Turn	Left	Thru	Right	U-Turn	Left	Thru	Right	U-Turn	Left	Thru	Right			West	East	South	North
7:00 AM	0	0	127	0	0	0	107	0	0	0	0	0	0	0	0	3	237	1,267	0	0	0	0
7:15 AM	0	0	150	0	0	0	220	0	0	0	0	0	0	0	0	0	370	1,310	0	0	0	0
7:30 AM	0	0	108	0	0	0	192	1	0	0	0	0	0	2	0	8	311	1,232	0	0	0	0
7:45 AM	0	0	128	0	0	0	217	0	0	0	0	0	0	1	0	3	349	1,201	0	0	0	0
8:00 AM	0	6	125	0	0	0	138	0	0	0	0	0	0	5	0	6	280	1,103	0	0	0	0
8:15 AM	0	2	103	0	0	0	174	3	0	0	0	0	0	0	0	10	292		0	0	0	0
8:30 AM	0	0	120	0	0	0	153	0	0	0	0	0	0	0	0	7	280		0	0	0	1
8:45 AM	0	1	92	0	0	0	152	0	0	0	0	0	0	0	0	6	251		0	0	0	0
Count Total	0	9	953	0	0	0	1,353	4	0	0	0	0	0	8	0	43	2,370		0	0	0	1
Peak Hour	0	6	511	0	0	0	767	1	0	0	0	0	0	8	0	17	1,310		0	0	0	0



(303) 216-2439
www.alltrafficdata.net

Location: 5 SITE ACCESS & SAN PEDRO DR NE AM

Date: Tuesday, December 14, 2021

Peak Hour: 07:30 AM - 08:30 AM

Peak 15-Minutes: 07:45 AM - 08:00 AM

Peak Hour - All Vehicles

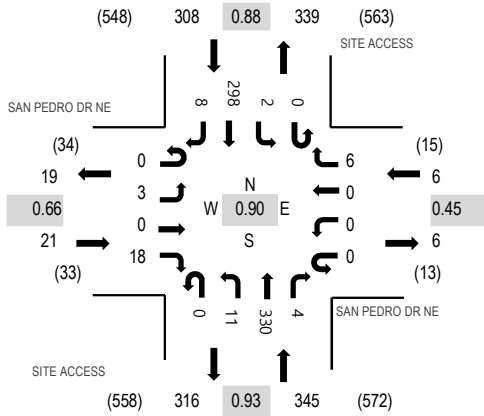

Note: Total study counts contained in parentheses.

Peak Hour - Pedestrians/Bicycles on Crosswalk

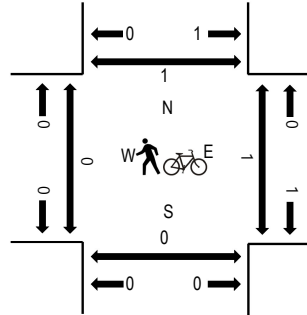

Traffic Counts

Interval Start Time	SAN PEDRO DR NE Eastbound				SAN PEDRO DR NE Westbound				SITE ACCESS Northbound				SITE ACCESS Southbound				Total	Rolling Hour	Pedestrian Crossings				
	U-Turn	Left	Thru	Right	U-Turn	Left	Thru	Right	U-Turn	Left	Thru	Right	U-Turn	Left	Thru	Right			West	East	South	North	
7:00 AM	0	0	0	1	0	0	0	2	0	0	44	1	0	0	0	48	0	96	591	0	0	0	0
7:15 AM	0	0	0	4	0	0	0	0	0	3	47	0	0	0	0	76	4	134	657	0	0	0	0
7:30 AM	0	1	0	1	0	0	0	2	0	2	78	0	0	0	0	87	2	173	680	0	0	0	1
7:45 AM	0	0	0	8	0	0	0	2	0	4	79	3	0	2	0	88	2	188	634	0	0	0	0
8:00 AM	0	1	0	4	0	0	0	2	0	3	90	0	0	0	0	59	3	162	577	0	0	0	0
8:15 AM	0	1	0	5	0	0	0	0	0	2	83	1	0	0	0	64	1	157		0	1	0	0
8:30 AM	0	1	0	1	0	0	0	2	0	1	61	1	0	0	0	59	1	127		0	0	0	0
8:45 AM	0	0	0	5	0	0	0	5	0	3	62	4	0	1	0	48	3	131		0	0	0	0
Count Total	0	4	0	29	0	0	0	15	0	18	544	10	0	3	0	529	16	1,168		0	1	0	1
Peak Hour	0	3	0	18	0	0	0	6	0	11	330	4	0	2	0	298	8	680		0	1	0	1



(303) 216-2439
www.alltrafficdata.net

Location: 6 SIGNAL AVE NE & SAN PEDRO DR NE AM

Date: Tuesday, December 14, 2021

Peak Hour: 07:30 AM - 08:30 AM

Peak 15-Minutes: 07:45 AM - 08:00 AM

Peak Hour - All Vehicles

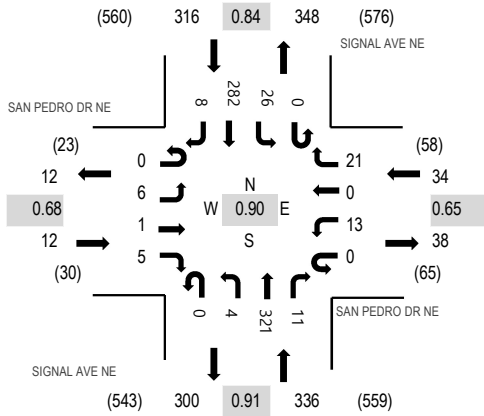

Peak Hour - Pedestrians/Bicycles on Crosswalk

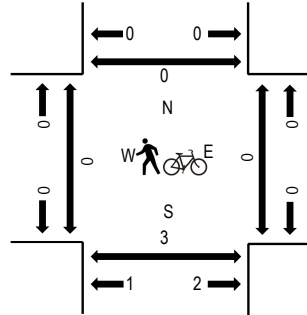

Note: Total study counts contained in parentheses.

Traffic Counts

Interval Start Time	SAN PEDRO DR NE Eastbound				SAN PEDRO DR NE Westbound				SIGNAL AVE NE Northbound				SIGNAL AVE NE Southbound				Total	Rolling Hour	Pedestrian Crossings			
	U-Turn	Left	Thru	Right	U-Turn	Left	Thru	Right	U-Turn	Left	Thru	Right	U-Turn	Left	Thru	Right			West	East	South	North
7:00 AM	0	1	0	4	0	1	0	1	0	0	42	2	0	4	42	2	99	616	0	0	0	0
7:15 AM	0	2	0	5	0	3	0	3	0	0	45	3	0	6	73	2	142	678	0	0	0	0
7:30 AM	0	1	1	2	0	5	0	8	0	1	73	3	0	4	83	0	181	698	0	0	1	0
7:45 AM	0	1	0	2	0	2	0	7	0	1	81	2	0	6	88	4	194	651	0	0	2	0
8:00 AM	0	2	0	0	0	1	0	4	0	1	88	3	0	6	54	2	161	591	0	0	0	0
8:15 AM	0	2	0	1	0	5	0	2	0	1	79	3	0	10	57	2	162		0	0	0	0
8:30 AM	0	2	0	0	0	2	1	3	0	1	61	2	0	4	56	2	134		0	0	0	0
8:45 AM	0	1	0	3	0	5	0	5	0	2	62	3	0	3	49	1	134		0	0	0	0
Count Total	0	12	1	17	0	24	1	33	0	7	531	21	0	43	502	15	1,207		0	0	3	0
Peak Hour	0	6	1	5	0	13	0	21	0	4	321	11	0	26	282	8	698		0	0	3	0



(303) 216-2439
www.alltrafficdata.net

Location: 1 SAN PEDRO DR NE & ALAMEDA BLVD NE PM

Date: Tuesday, December 14, 2021

Peak Hour: 04:15 PM - 05:15 PM

Peak 15-Minutes: 05:00 PM - 05:15 PM

Peak Hour - All Vehicles

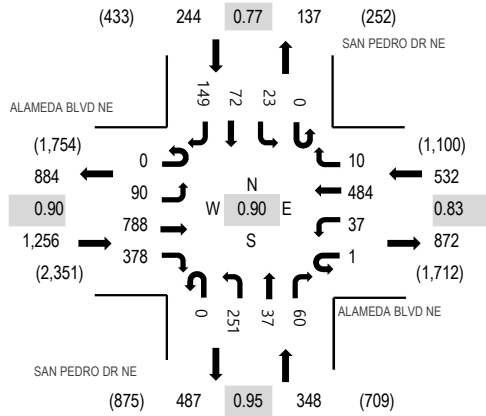

Note: Total study counts contained in parentheses.

Peak Hour - Pedestrians/Bicycles on Crosswalk

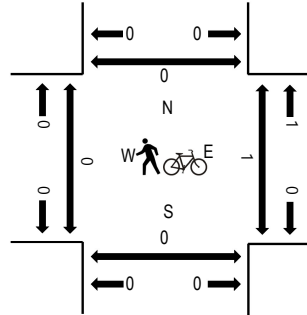

Traffic Counts

Interval Start Time	ALAMEDA BLVD NE Eastbound				ALAMEDA BLVD NE Westbound				SAN PEDRO DR NE Northbound				SAN PEDRO DR NE Southbound				Total	Rolling Hour	Pedestrian Crossings			
	U-Turn	Left	Thru	Right	U-Turn	Left	Thru	Right	U-Turn	Left	Thru	Right	U-Turn	Left	Thru	Right			West	East	South	North
4:00 PM	0	12	193	68	2	15	142	9	0	59	17	20	0	3	15	36	591	2,310	0	2	0	0
4:15 PM	0	21	205	90	0	12	132	0	0	59	13	10	0	4	21	32	599	2,380	0	0	0	0
4:30 PM	0	24	184	92	0	11	109	0	0	66	5	13	0	5	13	32	554	2,350	0	0	0	0
4:45 PM	0	21	186	85	1	8	114	6	0	55	12	20	0	6	14	38	566	2,366	0	0	0	0
5:00 PM	0	24	213	111	0	6	129	4	0	71	7	17	0	8	24	47	661	2,283	0	0	0	0
5:15 PM	0	21	196	78	1	27	114	3	0	60	12	13	0	4	9	31	569		0	0	0	0
5:30 PM	0	8	216	69	0	11	126	0	0	64	11	16	0	2	9	38	570		0	0	0	0
5:45 PM	0	16	149	69	0	14	104	0	0	61	6	22	0	3	4	35	483		0	0	0	0
Count Total	0	147	1,542	662	4	104	970	22	0	495	83	131	0	35	109	289	4,593		0	2	0	0
Peak Hour	0	90	788	378	1	37	484	10	0	251	37	60	0	23	72	149	2,380		0	0	0	0



(303) 216-2439
www.alltrafficdata.net

Location: 2 SITE ACCESS & ALAMEDA BLVD NE PM

Date: Tuesday, December 14, 2021

Peak Hour: 04:45 PM - 05:45 PM

Peak 15-Minutes: 05:00 PM - 05:15 PM

Peak Hour - All Vehicles

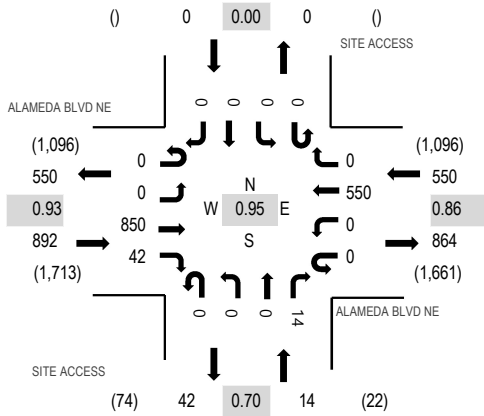

Note: Total study counts contained in parentheses.

Peak Hour - Pedestrians/Bicycles on Crosswalk

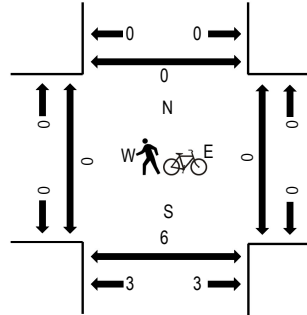

Traffic Counts

Interval Start Time	ALAMEDA BLVD NE Eastbound				ALAMEDA BLVD NE Westbound				SITE ACCESS Northbound				SITE ACCESS Southbound				Total	Rolling Hour	Pedestrian Crossings			
	U-Turn	Left	Thru	Right	U-Turn	Left	Thru	Right	U-Turn	Left	Thru	Right	U-Turn	Left	Thru	Right			West	East	South	North
4:00 PM	0	0	210	9	0	0	162	0	0	0	0	3	0	0	0	0	384	1,418	0	0	2	0
4:15 PM	0	0	212	7	0	0	146	0	0	0	0	2	0	0	0	0	367	1,418	0	0	0	0
4:30 PM	0	0	195	9	0	0	121	0	0	0	0	2	0	0	0	0	327	1,412	0	0	0	0
4:45 PM	0	0	198	8	0	0	129	0	0	0	0	5	0	0	0	0	340	1,456	0	0	4	0
5:00 PM	0	0	231	8	0	0	140	0	0	0	0	5	0	0	0	0	384	1,413	0	0	2	0
5:15 PM	0	0	205	11	0	0	143	0	0	0	0	2	0	0	0	0	361		0	0	0	0
5:30 PM	0	0	216	15	0	0	138	0	0	0	0	2	0	0	0	0	371		0	0	0	0
5:45 PM	0	0	172	7	0	0	117	0	0	0	0	1	0	0	0	0	297		0	0	0	0
Count Total	0	0	1,639	74	0	0	1,096	0	0	0	0	22	0	0	0	0	2,831		0	0	8	0
Peak Hour	0	0	850	42	0	0	550	0	0	0	0	14	0	0	0	0	1,456		0	0	6	0



(303) 216-2439
www.alltrafficdata.net

Location: 3 RESERVE APT ACCESS & ALAMEDA BLVD NE PM

Date: Tuesday, December 14, 2021

Peak Hour: 04:45 PM - 05:45 PM

Peak 15-Minutes: 05:00 PM - 05:15 PM

Peak Hour - All Vehicles

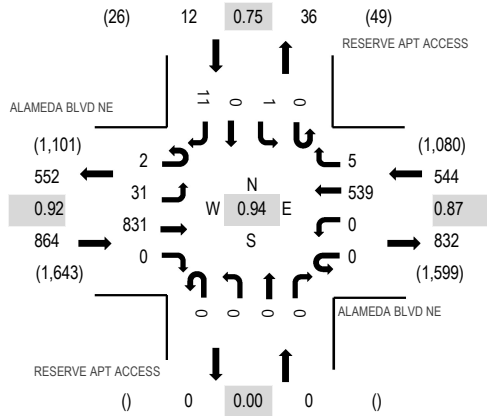

Note: Total study counts contained in parentheses.

Peak Hour - Pedestrians/Bicycles on Crosswalk

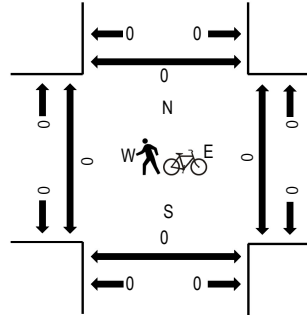

Traffic Counts

Interval Start Time	ALAMEDA BLVD NE Eastbound				ALAMEDA BLVD NE Westbound				RESERVE APT ACCESS Northbound				RESERVE APT ACCESS Southbound				Total	Rolling Hour	Pedestrian Crossings			
	U-Turn	Left	Thru	Right	U-Turn	Left	Thru	Right	U-Turn	Left	Thru	Right	U-Turn	Left	Thru	Right			West	East	South	North
4:00 PM	0	3	199	0	0	0	157	1	0	0	0	0	0	1	0	2	363	1,369	0	1	0	0
4:15 PM	0	3	204	0	0	0	144	0	0	0	0	0	0	1	0	2	354	1,385	0	1	0	0
4:30 PM	2	4	194	0	0	0	117	0	0	0	0	0	0	1	0	2	320	1,385	0	0	0	0
4:45 PM	1	8	193	0	0	0	127	1	0	0	0	0	0	0	0	2	332	1,420	0	0	0	0
5:00 PM	0	6	228	0	0	0	140	2	0	0	0	0	0	1	0	2	379	1,380	0	0	0	0
5:15 PM	0	12	199	0	0	0	139	0	0	0	0	0	0	0	0	4	354		0	0	0	0
5:30 PM	1	5	211	0	0	0	133	2	0	0	0	0	0	0	0	3	355		0	0	0	0
5:45 PM	1	2	167	0	0	0	117	0	0	0	0	0	0	0	0	5	292		0	0	0	0
Count Total	5	43	1,595	0	0	0	1,074	6	0	0	0	0	0	4	0	22	2,749		0	2	0	0
Peak Hour	2	31	831	0	0	0	539	5	0	0	0	0	0	1	0	11	1,420		0	0	0	0



(303) 216-2439
www.alltrafficdata.net

Location: 5 SITE ACCESS & SAN PEDRO DR NE PM

Date: Tuesday, December 14, 2021

Peak Hour: 04:15 PM - 05:15 PM

Peak 15-Minutes: 05:00 PM - 05:15 PM

Peak Hour - All Vehicles

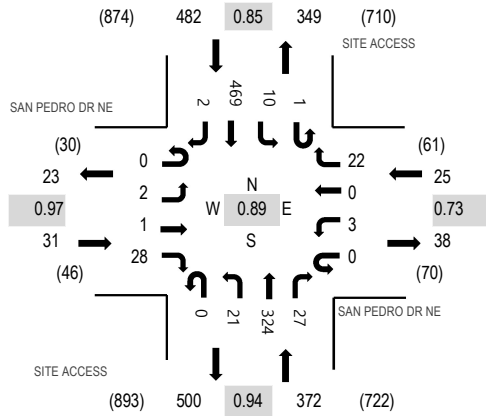

Peak Hour - Pedestrians/Bicycles on Crosswalk

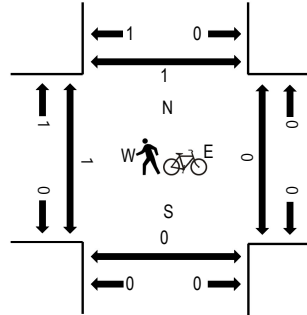

Note: Total study counts contained in parentheses.

Traffic Counts

Interval Start Time	SAN PEDRO DR NE Eastbound				SAN PEDRO DR NE Westbound				SITE ACCESS Northbound				SITE ACCESS Southbound				Total	Rolling Hour	Pedestrian Crossings			
	U-Turn	Left	Thru	Right	U-Turn	Left	Thru	Right	U-Turn	Left	Thru	Right	U-Turn	Left	Thru	Right			West	East	South	North
4:00 PM	0	1	0	1	0	1	0	8	0	0	86	6	1	4	94	1	203	857	0	0	0	0
4:15 PM	0	2	0	6	0	1	0	4	0	5	79	6	0	5	117	1	226	910	1	0	0	1
4:30 PM	0	0	0	7	0	1	0	3	0	9	79	6	0	0	114	0	219	896	0	0	0	0
4:45 PM	0	0	1	7	0	0	0	8	0	5	76	8	1	4	99	0	209	865	0	0	0	0
5:00 PM	0	0	0	8	0	1	0	7	0	2	90	7	0	1	139	1	256	846	0	0	0	0
5:15 PM	0	0	0	4	0	0	0	9	0	0	78	6	0	1	114	0	212		0	0	0	0
5:30 PM	0	0	0	3	0	0	0	6	0	0	85	4	0	1	89	0	188		0	0	0	0
5:45 PM	0	0	0	6	0	1	0	11	0	6	76	3	0	7	80	0	190		1	1	0	0
Count Total	0	3	1	42	0	5	0	56	0	27	649	46	2	23	846	3	1,703		2	1	0	1
Peak Hour	0	2	1	28	0	3	0	22	0	21	324	27	1	10	469	2	910		1	0	0	1



(303) 216-2439
www.alltrafficdata.net

Location: 6 SIGNAL AVE NE & SAN PEDRO DR NE PM

Date: Tuesday, December 14, 2021

Peak Hour: 04:15 PM - 05:15 PM

Peak 15-Minutes: 05:00 PM - 05:15 PM

Peak Hour - All Vehicles

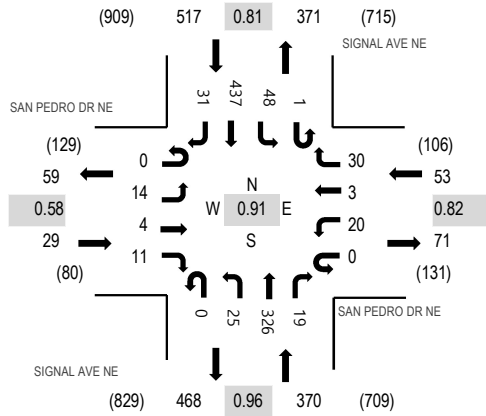

Peak Hour - Pedestrians/Bicycles on Crosswalk

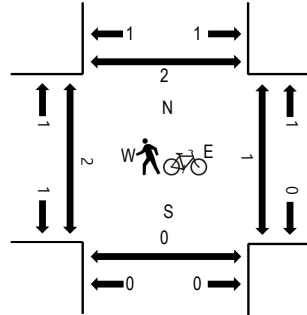

Note: Total study counts contained in parentheses.

Traffic Counts

Interval Start Time	SAN PEDRO DR NE Eastbound				SAN PEDRO DR NE Westbound				SIGNAL AVE NE Northbound				SIGNAL AVE NE Southbound				Total	Rolling Hour	Pedestrian Crossings			
	U-Turn	Left	Thru	Right	U-Turn	Left	Thru	Right	U-Turn	Left	Thru	Right	U-Turn	Left	Thru	Right			West	East	South	North
4:00 PM	0	5	0	4	0	7	0	6	0	2	76	6	1	9	78	6	200	902	0	0	0	0
4:15 PM	0	4	0	4	0	4	0	12	0	5	74	5	1	7	117	4	237	969	1	1	0	1
4:30 PM	0	3	3	0	0	7	2	8	0	11	81	3	0	15	93	14	240	963	0	0	0	1
4:45 PM	0	6	1	7	0	7	0	3	0	4	83	8	0	5	99	2	225	938	1	0	0	0
5:00 PM	0	1	0	0	0	2	1	7	0	5	88	3	0	21	128	11	267	902	0	0	0	0
5:15 PM	0	9	1	5	0	7	3	7	0	7	67	5	0	12	93	15	231		0	0	0	0
5:30 PM	0	8	3	12	0	8	0	5	0	5	79	3	0	9	72	11	215		0	0	0	0
5:45 PM	0	2	1	1	0	6	0	4	0	9	75	5	0	6	68	12	189		0	0	0	0
Count Total	0	38	9	33	0	48	6	52	0	48	623	38	2	84	748	75	1,804		2	1	0	2
Peak Hour	0	14	4	11	0	20	3	30	0	25	326	19	1	48	437	31	969		2	1	0	2

All Traffic Data Services, LLC
www.alltrafficdata.net

Date Start: 14-Dec-21
Site Code: 8
Station ID: 8
SAN PEDRO DR NE S.O. ALAMEDA BLVD NE

Start Time	14-Dec-21 Tue	NB	SB	Total						
12:00 AM		6	11	17						
01:00		10	6	16						
02:00		4	10	14						
03:00		4	5	9						
04:00		13	14	27						
05:00		47	54	101						
06:00		142	141	283						
07:00		248	307	555						
08:00		321	239	560						
09:00		251	247	498						
10:00		250	241	491						
11:00		316	339	655						
12:00 PM		410	378	788						
01:00		426	308	734						
02:00		333	344	677						
03:00		334	407	741						
04:00		349	444	793						
05:00		360	431	791						
06:00		278	241	519						
07:00		221	165	386						
08:00		181	113	294						
09:00		108	57	165						
10:00		55	52	107						
11:00		37	40	77						
Total		4704	4594	9298						
Percent		50.6%	49.4%							
AM Peak	-	08:00	11:00	-	-	-	-	-	-	11:00
Vol.	-	321	339	-	-	-	-	-	-	655
PM Peak	-	13:00	16:00	-	-	-	-	-	-	16:00
Vol.	-	426	444	-	-	-	-	-	-	793
Grand Total		4704	4594							9298
Percent		50.6%	49.4%							
ADT		ADT 9,298	AADT 9,298							

All Traffic Data Services, LLC
www.alltrafficdata.net

Date Start: 14-Dec-21
Site Code: 7
Station ID: 7
ALAMEDA BLVD NE E.O. SAN PEDRO DR NE

Start Time	14-Dec-21 Tue	EB	WB	Total						
12:00 AM		42	22	64						
01:00		16	13	29						
02:00		5	4	9						
03:00		8	12	20						
04:00		15	24	39						
05:00		44	100	144						
06:00		186	312	498						
07:00		520	755	1275						
08:00		459	639	1098						
09:00		397	423	820						
10:00		402	415	817						
11:00		447	451	898						
12:00 PM		543	473	1016						
01:00		506	483	989						
02:00		579	600	1179						
03:00		581	621	1202						
04:00		852	561	1413						
05:00		860	539	1399						
06:00		561	387	948						
07:00		340	221	561						
08:00		252	173	425						
09:00		190	104	294						
10:00		104	78	182						
11:00		98	19	117						
Total		8007	7429	15436						
Percent		51.9%	48.1%							
AM Peak	-	07:00	07:00	-	-	-	-	-	-	07:00
Vol.	-	520	755	-	-	-	-	-	-	1275
PM Peak	-	17:00	15:00	-	-	-	-	-	-	16:00
Vol.	-	860	621	-	-	-	-	-	-	1413
Grand Total		8007	7429							15436
Percent		51.9%	48.1%							
ADT		ADT 15,436	AADT 15,436							



Appendix D – Existing Capacity Analysis

1: San Pedro Drive & Alameda Boulevard

01/27/2022



Movement	EBL	EBT	EBR	WBL	WBT	WBR	NBL	NBT	NBR	SBL	SBT	SBR
Lane Configurations	↘	↑↑	↗	↘	↑↑		↘	↑↑		↘	↑↑	
Traffic Volume (veh/h)	73	494	243	53	716	19	217	51	33	3	26	124
Future Volume (veh/h)	73	494	243	53	716	19	217	51	33	3	26	124
Initial Q (Qb), veh	0	0	0	0	0	0	0	0	0	0	0	0
Ped-Bike Adj(A_pbT)	1.00		1.00	1.00		1.00	1.00		1.00	1.00		1.00
Parking Bus, Adj	1.00	1.00	1.00	1.00	1.00	1.00	1.00	1.00	1.00	1.00	1.00	1.00
Work Zone On Approach		No			No			No			No	
Adj Sat Flow, veh/h/ln	1870	1870	1870	1870	1870	1870	1870	1870	1870	1870	1870	1870
Adj Flow Rate, veh/h	79	537	264	58	778	21	236	55	36	3	28	135
Peak Hour Factor	0.92	0.92	0.92	0.92	0.92	0.92	0.92	0.92	0.92	0.92	0.92	0.92
Percent Heavy Veh, %	2	2	2	2	2	2	2	2	2	2	2	2
Cap, veh/h	522	1819	812	287	1316	36	354	516	309	232	197	175
Arrive On Green	0.18	0.51	0.51	0.04	0.37	0.37	0.13	0.24	0.24	0.00	0.11	0.11
Sat Flow, veh/h	1781	3554	1585	1781	3535	95	1781	2136	1280	1781	1777	1585
Grp Volume(v), veh/h	79	537	264	58	391	408	236	45	46	3	28	135
Grp Sat Flow(s),veh/h/ln	1781	1777	1585	1781	1777	1853	1781	1777	1640	1781	1777	1585
Q Serve(g_s), s	0.0	7.8	8.8	2.0	15.9	15.9	10.1	1.8	2.0	0.1	1.3	7.5
Cycle Q Clear(g_c), s	0.0	7.8	8.8	2.0	15.9	15.9	10.1	1.8	2.0	0.1	1.3	7.5
Prop In Lane	1.00		1.00	1.00		0.05	1.00		0.78	1.00		1.00
Lane Grp Cap(c), veh/h	522	1819	812	287	661	690	354	429	396	232	197	175
V/C Ratio(X)	0.15	0.30	0.33	0.20	0.59	0.59	0.67	0.10	0.12	0.01	0.14	0.77
Avail Cap(c_a), veh/h	522	1819	812	340	661	690	381	523	483	333	365	326
HCM Platoon Ratio	1.00	1.00	1.00	1.00	1.00	1.00	1.00	1.00	1.00	1.00	1.00	1.00
Upstream Filter(I)	1.00	1.00	1.00	1.00	1.00	1.00	1.00	1.00	1.00	1.00	1.00	1.00
Uniform Delay (d), s/veh	21.2	12.6	12.9	20.6	22.7	22.7	28.4	26.6	26.6	35.3	36.2	38.9
Incr Delay (d2), s/veh	0.1	0.4	1.1	0.3	3.9	3.7	4.0	0.1	0.1	0.0	0.3	6.9
Initial Q Delay(d3),s/veh	0.0	0.0	0.0	0.0	0.0	0.0	0.0	0.0	0.0	0.0	0.0	0.0
%ile BackOfQ(50%),veh/ln	1.2	3.0	3.1	0.8	7.0	7.3	4.5	0.7	0.8	0.1	0.6	3.2
Unsig. Movement Delay, s/veh												
LnGrp Delay(d),s/veh	21.3	13.0	13.9	20.9	26.6	26.4	32.4	26.7	26.8	35.4	36.5	45.8
LnGrp LOS	C	B	B	C	C	C	C	C	C	D	D	D
Approach Vol, veh/h		880			857			327			166	
Approach Delay, s/veh		14.0			26.1			30.8			44.1	
Approach LOS		B			C			C			D	
Timer - Assigned Phs	1	2	3	4	5	6	7	8				
Phs Duration (G+Y+Rc), s	8.3	50.6	16.6	14.5	20.9	38.0	4.9	26.2				
Change Period (Y+Rc), s	4.5	4.5	4.5	4.5	4.5	4.5	4.5	4.5				
Max Green Setting (Gmax), s	6.5	33.5	13.5	18.5	6.5	33.5	5.5	26.5				
Max Q Clear Time (g_c+I1), s	4.0	10.8	12.1	9.5	2.0	17.9	2.1	4.0				
Green Ext Time (p_c), s	0.0	4.5	0.1	0.5	0.1	4.4	0.0	0.4				
Intersection Summary												
HCM 6th Ctrl Delay			23.4									
HCM 6th LOS			C									

Intersection						
Int Delay, s/veh	0					
Movement	EBT	EBR	WBL	WBT	NBL	NBR
Lane Configurations	↑↑			↑↑		↑
Traffic Vol, veh/h	521	10	0	790	0	0
Future Vol, veh/h	521	10	0	790	0	0
Conflicting Peds, #/hr	0	0	0	0	0	0
Sign Control	Free	Free	Free	Free	Stop	Stop
RT Channelized	-	None	-	None	-	None
Storage Length	-	-	-	-	-	0
Veh in Median Storage, #	0	-	-	0	0	-
Grade, %	0	-	-	0	0	-
Peak Hour Factor	88	88	88	88	88	88
Heavy Vehicles, %	2	2	2	2	2	2
Mvmt Flow	592	11	0	898	0	0

Major/Minor	Major1	Major2	Minor1	Minor2	Minor3
Conflicting Flow All	0	0	-	-	302
Stage 1	-	-	-	-	-
Stage 2	-	-	-	-	-
Critical Hdwy	-	-	-	-	6.94
Critical Hdwy Stg 1	-	-	-	-	-
Critical Hdwy Stg 2	-	-	-	-	-
Follow-up Hdwy	-	-	-	-	3.32
Pot Cap-1 Maneuver	-	-	0	-	*869
Stage 1	-	-	0	-	-
Stage 2	-	-	0	-	-
Platoon blocked, %	-	-	-	-	1
Mov Cap-1 Maneuver	-	-	-	-	*869
Mov Cap-2 Maneuver	-	-	-	-	-
Stage 1	-	-	-	-	-
Stage 2	-	-	-	-	-

Approach	EB	WB	NB
HCM Control Delay, s	0	0	0
HCM LOS			A

Minor Lane/Major Mvmt	NBLn1	EBT	EBR	WBT
Capacity (veh/h)	-	-	-	-
HCM Lane V/C Ratio	-	-	-	-
HCM Control Delay (s)	0	-	-	-
HCM Lane LOS	A	-	-	-
HCM 95th %tile Q(veh)	-	-	-	-

Notes
 ~: Volume exceeds capacity \$: Delay exceeds 300s +: Computation Not Defined *: All major volume in platoon

3: Alameda Boulevard & Driveway B

01/27/2022

Intersection						
Int Delay, s/veh	0.3					
Movement	EBL	EBT	WBT	WBR	SBL	SBR
Lane Configurations	↘	↑↑	↑↑	↗	↘	
Traffic Vol, veh/h	6	511	767	1	8	17
Future Vol, veh/h	6	511	767	1	8	17
Conflicting Peds, #/hr	0	0	0	0	0	0
Sign Control	Free	Free	Free	Free	Stop	Stop
RT Channelized	-	None	-	None	-	None
Storage Length	90	-	-	90	0	-
Veh in Median Storage, #	-	0	0	-	0	-
Grade, %	-	0	0	-	0	-
Peak Hour Factor	89	89	89	89	89	89
Heavy Vehicles, %	2	2	2	2	2	2
Mvmt Flow	7	574	862	1	9	19

Major/Minor	Major1	Major2	Minor2		
Conflicting Flow All	863	0	-	0	1163 431
Stage 1	-	-	-	-	862 -
Stage 2	-	-	-	-	301 -
Critical Hdwy	4.14	-	-	-	6.84 6.94
Critical Hdwy Stg 1	-	-	-	-	5.84 -
Critical Hdwy Stg 2	-	-	-	-	5.84 -
Follow-up Hdwy	2.22	-	-	-	3.52 3.32
Pot Cap-1 Maneuver	775	-	-	-	*269 573
Stage 1	-	-	-	-	*374 -
Stage 2	-	-	-	-	*853 -
Platoon blocked, %		-	-	-	1
Mov Cap-1 Maneuver	775	-	-	-	*267 573
Mov Cap-2 Maneuver	-	-	-	-	*267 -
Stage 1	-	-	-	-	*371 -
Stage 2	-	-	-	-	*853 -

Approach	EB	WB	SB
HCM Control Delay, s	0.1	0	14.2
HCM LOS			B

Minor Lane/Major Mvmt	EBL	EBT	WBT	WBR	SBLn1
Capacity (veh/h)	775	-	-	-	419
HCM Lane V/C Ratio	0.009	-	-	-	0.067
HCM Control Delay (s)	9.7	-	-	-	14.2
HCM Lane LOS	A	-	-	-	B
HCM 95th %tile Q(veh)	0	-	-	-	0.2

Notes
 ~: Volume exceeds capacity \$: Delay exceeds 300s +: Computation Not Defined *: All major volume in platoon

4: San Pedro Drive & Driveway C

01/27/2022

Intersection						
Int Delay, s/veh	0.1					
Movement	WBL	WBR	NBT	NBR	SBL	SBT
Lane Configurations		↗	↕			↕
Traffic Vol, veh/h	0	6	294	5	0	323
Future Vol, veh/h	0	6	294	5	0	323
Conflicting Peds, #/hr	0	0	0	0	0	0
Sign Control	Stop	Stop	Free	Free	Free	Free
RT Channelized	-	None	-	None	-	None
Storage Length	-	0	-	100	-	-
Veh in Median Storage, #	0	-	0	-	-	0
Grade, %	0	-	0	-	-	0
Peak Hour Factor	87	87	87	87	87	87
Heavy Vehicles, %	2	2	2	2	2	2
Mvmt Flow	0	7	338	6	0	371

Major/Minor	Minor1	Major1	Major2			
Conflicting Flow All	-	172	0	0	-	-
Stage 1	-	-	-	-	-	-
Stage 2	-	-	-	-	-	-
Critical Hdwy	-	6.94	-	-	-	-
Critical Hdwy Stg 1	-	-	-	-	-	-
Critical Hdwy Stg 2	-	-	-	-	-	-
Follow-up Hdwy	-	3.32	-	-	-	-
Pot Cap-1 Maneuver	0	842	-	-	0	-
Stage 1	0	-	-	-	0	-
Stage 2	0	-	-	-	0	-
Platoon blocked, %			-	-	-	-
Mov Cap-1 Maneuver	-	842	-	-	-	-
Mov Cap-2 Maneuver	-	-	-	-	-	-
Stage 1	-	-	-	-	-	-
Stage 2	-	-	-	-	-	-

Approach	WB	NB	SB
HCM Control Delay, s	9.3	0	0
HCM LOS	A		

Minor Lane/Major Mvmt	NBT	NBRWBLn1	SBT
Capacity (veh/h)	-	-	842
HCM Lane V/C Ratio	-	-	0.008
HCM Control Delay (s)	-	-	9.3
HCM Lane LOS	-	-	A
HCM 95th %tile Q(veh)	-	-	0

5: San Pedro Drive & Signal Avenue

01/27/2022

Intersection												
Int Delay, s/veh	1.2											
Movement	EBL	EBT	EBR	WBL	WBT	WBR	NBL	NBT	NBR	SBL	SBT	SBR
Lane Configurations		↕			↕			↕			↕	↕
Traffic Vol, veh/h	6	1	9	11	0	22	3	287	11	22	298	8
Future Vol, veh/h	6	1	9	11	0	22	3	287	11	22	298	8
Conflicting Peds, #/hr	0	0	0	0	0	0	0	0	0	0	0	0
Sign Control	Stop	Stop	Stop	Stop	Stop	Stop	Free	Free	Free	Free	Free	Free
RT Channelized	-	-	None	-	-	None	-	-	None	-	-	None
Storage Length	-	-	-	-	-	-	-	-	-	-	-	0
Veh in Median Storage, #	-	0	-	-	0	-	-	0	-	-	0	-
Grade, %	-	0	-	-	0	-	-	0	-	-	0	-
Peak Hour Factor	87	87	87	87	87	87	87	87	87	87	87	87
Heavy Vehicles, %	2	2	2	2	2	2	2	2	2	2	2	2
Mvmt Flow	7	1	10	13	0	25	3	330	13	25	343	9

Major/Minor	Minor2		Minor1		Major1		Major2					
Conflicting Flow All	748	742	343	746	745	337	352	0	0	343	0	0
Stage 1	393	393	-	343	343	-	-	-	-	-	-	-
Stage 2	355	349	-	403	402	-	-	-	-	-	-	-
Critical Hdwy	7.12	6.52	6.22	7.12	6.52	6.22	4.12	-	-	4.12	-	-
Critical Hdwy Stg 1	6.12	5.52	-	6.12	5.52	-	-	-	-	-	-	-
Critical Hdwy Stg 2	6.12	5.52	-	6.12	5.52	-	-	-	-	-	-	-
Follow-up Hdwy	3.518	4.018	3.318	3.518	4.018	3.318	2.218	-	-	2.218	-	-
Pot Cap-1 Maneuver	351	353	808	352	351	705	1229	-	-	1216	-	-
Stage 1	709	639	-	672	637	-	-	-	-	-	-	-
Stage 2	662	633	-	698	632	-	-	-	-	-	-	-
Platoon blocked, %	1	1	1	1	1	1	-	-	-	-	-	-
Mov Cap-1 Maneuver	331	343	808	339	341	705	1229	-	-	1216	-	-
Mov Cap-2 Maneuver	331	343	-	339	341	-	-	-	-	-	-	-
Stage 1	707	622	-	670	635	-	-	-	-	-	-	-
Stage 2	636	631	-	670	615	-	-	-	-	-	-	-

Approach	EB		WB		NB		SB	
HCM Control Delay, s	12.5		12.5		0.1		0.5	
HCM LOS	B		B					

Minor Lane/Major Mvmt	NBL	NBT	NBR	EBLn1WBLn1	SBL	SBT	SBR
Capacity (veh/h)	1229	-	-	497	518	1216	-
HCM Lane V/C Ratio	0.003	-	-	0.037	0.073	0.021	-
HCM Control Delay (s)	7.9	0	-	12.5	12.5	8	0
HCM Lane LOS	A	A	-	B	B	A	A
HCM 95th %tile Q(veh)	0	-	-	0.1	0.2	0.1	-

1: San Pedro Drive & Alameda Boulevard

01/27/2022



Movement	EBL	EBT	EBR	WBL	WBT	WBR	NBL	NBT	NBR	SBL	SBT	SBR
Lane Configurations	↖	↗	↘	↖	↗		↖	↗		↖	↗	
Traffic Volume (veh/h)	90	788	378	37	484	10	251	37	60	23	72	149
Future Volume (veh/h)	90	788	378	37	484	10	251	37	60	23	72	149
Initial Q (Qb), veh	0	0	0	0	0	0	0	0	0	0	0	0
Ped-Bike Adj(A_pbT)	1.00		1.00	1.00		1.00	1.00		1.00	1.00		1.00
Parking Bus, Adj	1.00	1.00	1.00	1.00	1.00	1.00	1.00	1.00	1.00	1.00	1.00	1.00
Work Zone On Approach		No			No			No			No	
Adj Sat Flow, veh/h/ln	1870	1870	1870	1870	1870	1870	1870	1870	1870	1870	1870	1870
Adj Flow Rate, veh/h	100	876	420	41	538	11	279	41	67	26	80	166
Peak Hour Factor	0.90	0.90	0.90	0.90	0.90	0.90	0.90	0.90	0.90	0.90	0.90	0.90
Percent Heavy Veh, %	2	2	2	2	2	2	2	2	2	2	2	2
Cap, veh/h	544	1714	764	193	1326	27	382	454	405	297	235	210
Arrive On Green	0.15	0.48	0.48	0.04	0.37	0.37	0.15	0.26	0.26	0.03	0.13	0.13
Sat Flow, veh/h	1781	3554	1585	1781	3561	73	1781	1777	1585	1781	1777	1585
Grp Volume(v), veh/h	100	876	420	41	268	281	279	41	67	26	80	166
Grp Sat Flow(s),veh/h/ln	1781	1777	1585	1781	1777	1857	1781	1777	1585	1781	1777	1585
Q Serve(g_s), s	0.0	15.2	16.8	1.4	10.0	10.1	11.6	1.6	3.0	1.1	3.7	9.1
Cycle Q Clear(g_c), s	0.0	15.2	16.8	1.4	10.0	10.1	11.6	1.6	3.0	1.1	3.7	9.1
Prop In Lane	1.00		1.00	1.00		0.04	1.00		1.00	1.00		1.00
Lane Grp Cap(c), veh/h	544	1714	764	193	661	691	382	454	405	297	235	210
V/C Ratio(X)	0.18	0.51	0.55	0.21	0.41	0.41	0.73	0.09	0.17	0.09	0.34	0.79
Avail Cap(c_a), veh/h	544	1714	764	259	661	691	382	523	467	359	365	326
HCM Platoon Ratio	1.00	1.00	1.00	1.00	1.00	1.00	1.00	1.00	1.00	1.00	1.00	1.00
Upstream Filter(I)	1.00	1.00	1.00	1.00	1.00	1.00	1.00	1.00	1.00	1.00	1.00	1.00
Uniform Delay (d), s/veh	19.3	16.0	16.4	21.6	20.9	20.9	26.7	25.5	26.0	32.3	35.5	37.9
Incr Delay (d2), s/veh	0.2	1.1	2.8	0.5	1.8	1.8	7.0	0.1	0.2	0.1	0.9	7.0
Initial Q Delay(d3),s/veh	0.0	0.0	0.0	0.0	0.0	0.0	0.0	0.0	0.0	0.0	0.0	0.0
%ile BackOfQ(50%),veh/ln	1.4	6.0	6.2	0.6	4.3	4.5	5.5	0.7	1.1	0.5	1.6	3.9
Unsig. Movement Delay, s/veh												
LnGrp Delay(d),s/veh	19.5	17.1	19.2	22.2	22.7	22.7	33.7	25.6	26.2	32.4	36.3	44.9
LnGrp LOS	B	B	B	C	C	C	C	C	C	C	D	D
Approach Vol, veh/h		1396			590			387			272	
Approach Delay, s/veh		17.9			22.7			31.5			41.2	
Approach LOS		B			C			C			D	
Timer - Assigned Phs	1	2	3	4	5	6	7	8				
Phs Duration (G+Y+Rc), s	7.7	47.9	18.0	16.4	17.6	38.0	6.9	27.5				
Change Period (Y+Rc), s	4.5	4.5	4.5	4.5	4.5	4.5	4.5	4.5				
Max Green Setting (Gmax), s	6.5	33.5	13.5	18.5	6.5	33.5	5.5	26.5				
Max Q Clear Time (g_c+I1), s	3.4	18.8	13.6	11.1	2.0	12.1	3.1	5.0				
Green Ext Time (p_c), s	0.0	6.6	0.0	0.8	0.1	3.1	0.0	0.5				
Intersection Summary												
HCM 6th Ctrl Delay				23.4								
HCM 6th LOS				C								

Intersection						
Int Delay, s/veh	0.1					
Movement	EBT	EBR	WBL	WBT	NBL	NBR
Lane Configurations	↑↑			↑↑		↑
Traffic Vol, veh/h	836	32	0	536	0	14
Future Vol, veh/h	836	32	0	536	0	14
Conflicting Peds, #/hr	0	0	0	0	0	0
Sign Control	Free	Free	Free	Free	Stop	Stop
RT Channelized	-	None	-	None	-	None
Storage Length	-	-	-	-	-	0
Veh in Median Storage, #	0	-	-	0	0	-
Grade, %	0	-	-	0	0	-
Peak Hour Factor	92	92	92	92	92	92
Heavy Vehicles, %	2	2	2	2	2	2
Mvmt Flow	909	35	0	583	0	15

Major/Minor	Major1	Major2	Minor1			
Conflicting Flow All	0	0	-	-	-	472
Stage 1	-	-	-	-	-	-
Stage 2	-	-	-	-	-	-
Critical Hdwy	-	-	-	-	-	6.94
Critical Hdwy Stg 1	-	-	-	-	-	-
Critical Hdwy Stg 2	-	-	-	-	-	-
Follow-up Hdwy	-	-	-	-	-	3.32
Pot Cap-1 Maneuver	-	-	0	-	0	*767
Stage 1	-	-	0	-	0	-
Stage 2	-	-	0	-	0	-
Platoon blocked, %	-	-	-	-	-	1
Mov Cap-1 Maneuver	-	-	-	-	-	*767
Mov Cap-2 Maneuver	-	-	-	-	-	-
Stage 1	-	-	-	-	-	-
Stage 2	-	-	-	-	-	-

Approach	EB	WB	NB
HCM Control Delay, s	0	0	9.8
HCM LOS			A

Minor Lane/Major Mvmt	NBLn1	EBT	EBR	WBT
Capacity (veh/h)	767	-	-	-
HCM Lane V/C Ratio	0.02	-	-	-
HCM Control Delay (s)	9.8	-	-	-
HCM Lane LOS	A	-	-	-
HCM 95th %tile Q(veh)	0.1	-	-	-

Notes
 ~: Volume exceeds capacity \$: Delay exceeds 300s +: Computation Not Defined *: All major volume in platoon

3: Alameda Boulevard & Driveway B

01/27/2022

Intersection						
Int Delay, s/veh	0.2					
Movement	EBL	EBT	WBT	WBR	SBL	SBR
Lane Configurations	↘	↑↑	↑↑	↗	↘	
Traffic Vol, veh/h	21	819	528	3	3	8
Future Vol, veh/h	21	819	528	3	3	8
Conflicting Peds, #/hr	0	0	0	0	0	0
Sign Control	Free	Free	Free	Free	Stop	Stop
RT Channelized	-	None	-	None	-	None
Storage Length	90	-	-	90	0	-
Veh in Median Storage, #	-	0	0	-	0	-
Grade, %	-	0	0	-	0	-
Peak Hour Factor	91	91	91	91	91	91
Heavy Vehicles, %	2	2	2	2	2	2
Mvmt Flow	23	900	580	3	3	9

Major/Minor	Major1	Major2	Minor2		
Conflicting Flow All	583	0	-	0	1076 290
Stage 1	-	-	-	-	580 -
Stage 2	-	-	-	-	496 -
Critical Hdwy	4.14	-	-	-	6.84 6.94
Critical Hdwy Stg 1	-	-	-	-	5.84 -
Critical Hdwy Stg 2	-	-	-	-	5.84 -
Follow-up Hdwy	2.22	-	-	-	3.52 3.32
Pot Cap-1 Maneuver	987	-	-	-	*484 707
Stage 1	-	-	-	-	*523 -
Stage 2	-	-	-	-	*724 -
Platoon blocked, %		-	-	-	1
Mov Cap-1 Maneuver	987	-	-	-	*473 707
Mov Cap-2 Maneuver	-	-	-	-	*473 -
Stage 1	-	-	-	-	*511 -
Stage 2	-	-	-	-	*724 -

Approach	EB	WB	SB
HCM Control Delay, s	0.2	0	10.9
HCM LOS			B

Minor Lane/Major Mvmt	EBL	EBT	WBT	WBR	SBLn1
Capacity (veh/h)	987	-	-	-	623
HCM Lane V/C Ratio	0.023	-	-	-	0.019
HCM Control Delay (s)	8.7	-	-	-	10.9
HCM Lane LOS	A	-	-	-	B
HCM 95th %tile Q(veh)	0.1	-	-	-	0.1

Notes
 ~: Volume exceeds capacity \$: Delay exceeds 300s +: Computation Not Defined *: All major volume in platoon

4: San Pedro Drive & Driveway C

01/27/2022

Intersection						
Int Delay, s/veh	0.3					
Movement	WBL	WBR	NBT	NBR	SBL	SBT
Lane Configurations		↗	↕			↕
Traffic Vol, veh/h	3	22	324	38	0	481
Future Vol, veh/h	3	22	324	38	0	481
Conflicting Peds, #/hr	0	0	0	0	0	0
Sign Control	Stop	Stop	Free	Free	Free	Free
RT Channelized	-	None	-	None	-	None
Storage Length	-	0	-	100	-	-
Veh in Median Storage, #	0	-	0	-	-	0
Grade, %	0	-	0	-	-	0
Peak Hour Factor	89	89	89	89	89	89
Heavy Vehicles, %	2	2	2	2	2	2
Mvmt Flow	3	25	364	43	0	540

Major/Minor	Minor1	Major1	Major2			
Conflicting Flow All	656	204	0	0	-	-
Stage 1	386	-	-	-	-	-
Stage 2	270	-	-	-	-	-
Critical Hdwy	6.84	6.94	-	-	-	-
Critical Hdwy Stg 1	5.84	-	-	-	-	-
Critical Hdwy Stg 2	5.84	-	-	-	-	-
Follow-up Hdwy	3.52	3.32	-	-	-	-
Pot Cap-1 Maneuver	*652	803	-	-	0	-
Stage 1	*656	-	-	-	0	-
Stage 2	*853	-	-	-	0	-
Platoon blocked, %	1	-	-	-	-	-
Mov Cap-1 Maneuver	*652	803	-	-	-	-
Mov Cap-2 Maneuver	*652	-	-	-	-	-
Stage 1	*656	-	-	-	-	-
Stage 2	*853	-	-	-	-	-

Approach	WB	NB	SB
HCM Control Delay, s	9.6	0	0
HCM LOS	A		

Minor Lane/Major Mvmt	NBT	NBRWBLn1	SBT
Capacity (veh/h)	-	-	803
HCM Lane V/C Ratio	-	-	0.031
HCM Control Delay (s)	-	-	9.6
HCM Lane LOS	-	-	A
HCM 95th %tile Q(veh)	-	-	0.1

Notes
 ~: Volume exceeds capacity \$: Delay exceeds 300s +: Computation Not Defined *: All major volume in platoon

5: San Pedro Drive & Signal Avenue

01/27/2022

Intersection												
Int Delay, s/veh	2.3											
Movement	EBL	EBT	EBR	WBL	WBT	WBR	NBL	NBT	NBR	SBL	SBT	SBR
Lane Configurations		↕			↕			↕			↕	↕
Traffic Vol, veh/h	14	4	11	20	3	30	25	326	19	48	437	31
Future Vol, veh/h	14	4	11	20	3	30	25	326	19	48	437	31
Conflicting Peds, #/hr	0	0	0	0	0	0	0	0	0	0	0	0
Sign Control	Stop	Stop	Stop	Stop	Stop	Stop	Free	Free	Free	Free	Free	Free
RT Channelized	-	-	None	-	-	None	-	-	None	-	-	None
Storage Length	-	-	-	-	-	-	-	-	-	-	-	0
Veh in Median Storage, #	-	0	-	-	0	-	-	0	-	-	0	-
Grade, %	-	0	-	-	0	-	-	0	-	-	0	-
Peak Hour Factor	91	91	91	91	91	91	91	91	91	91	91	91
Heavy Vehicles, %	2	2	2	2	2	2	2	2	2	2	2	2
Mvmt Flow	15	4	12	22	3	33	27	358	21	53	480	34

Major/Minor	Minor2		Minor1		Major1		Major2					
Conflicting Flow All	1027	1019	480	1034	1043	369	514	0	0	379	0	0
Stage 1	586	586	-	423	423	-	-	-	-	-	-	-
Stage 2	441	433	-	611	620	-	-	-	-	-	-	-
Critical Hdwy	7.12	6.52	6.22	7.12	6.52	6.22	4.12	-	-	4.12	-	-
Critical Hdwy Stg 1	6.12	5.52	-	6.12	5.52	-	-	-	-	-	-	-
Critical Hdwy Stg 2	6.12	5.52	-	6.12	5.52	-	-	-	-	-	-	-
Follow-up Hdwy	3.518	4.018	3.318	3.518	4.018	3.318	2.218	-	-	2.218	-	-
Pot Cap-1 Maneuver	205	218	*733	202	208	677	1060	-	-	1179	-	-
Stage 1	578	524	-	609	588	-	-	-	-	-	-	-
Stage 2	595	582	-	552	498	-	-	-	-	-	-	-
Platoon blocked, %	1	1	1	1	1	1	-	-	-	-	-	-
Mov Cap-1 Maneuver	179	198	*733	181	189	677	1060	-	-	1179	-	-
Mov Cap-2 Maneuver	179	198	-	181	189	-	-	-	-	-	-	-
Stage 1	559	491	-	590	569	-	-	-	-	-	-	-
Stage 2	545	563	-	504	466	-	-	-	-	-	-	-

Approach	EB		WB		NB		SB	
HCM Control Delay, s	21.1		19.2		0.6		0.8	
HCM LOS	C		C					

Minor Lane/Major Mvmt	NBL	NBT	NBR	EBLn1WBLn1	SBL	SBT	SBR
Capacity (veh/h)	1060	-	-	256	311	1179	-
HCM Lane V/C Ratio	0.026	-	-	0.124	0.187	0.045	-
HCM Control Delay (s)	8.5	0	-	21.1	19.2	8.2	0
HCM Lane LOS	A	A	-	C	C	A	A
HCM 95th %tile Q(veh)	0.1	-	-	0.4	0.7	0.1	-

Notes
 ~: Volume exceeds capacity \$: Delay exceeds 300s +: Computation Not Defined *: All major volume in platoon



Appendix E – Trip Generation



Whataburger
Sustainable Engineering Group

Completed: GT 1/12/2022
Checked: TG 1/27/2022

Pass-By Calculations

Land Use	SF	After Pass-By							After Pass-By							
		BEFORE REDUCTION AM PEAK HR			PASS- BY Rate %	AM REDUCED				BEFORE REDUCTION PM PEAK HR			PASS- BY Rate %	PM REDUCED		
		ENTER	EXIT	TOTAL		ENTER	EXIT	TOTAL		ENTER	EXIT	TOTAL		ENTER	EXIT	TOTAL
Fast-Food Restaurant with Drive-Through Window	2.999	68	66	134	49%	35	34	69		51	48	99	50%	26	24	50
TOTAL		68	66	134		35	34	69		51	48	99		26	24	50
						51%	52%	51%						51%	50%	51%



Appendix F – Previously Approved Site

Alameda / San Pedro Development
(SE Corner of Alameda Blvd. / San Pedro Dr.)

Traffic Impact Study

November 26, 2018

Presented to:

NM Dept. of Transportation
District 3

City of Albuquerque
Transportation Development Section

Prepared for:

Roy Solomon
Green Jeans West, LLC
2929 Monte Vista Blvd. NE
Albuquerque, NM 8710



A handwritten signature in blue ink that reads "Terry O. Brown".

Terry O. Brown P.E.
P.O. Box 92051
Albuquerque, NM 87199
505 · 883 · 8807

**Alameda / San Pedro Development
(SE Corner)
Traffic Impact Study**

Executive Summary

The purpose of this study is to evaluate the transportation conditions before and after implementation of the proposed Alameda / San Pedro Development, determine the impact of the development on the adjacent transportation system and recommend mitigation measures where necessary. This study is prepared to meet the requirements of the New Mexico Department of Transportation (NMDOT) and the City of Albuquerque associated with their review of the Alameda / San Pedro Development.

The proposed development is located in the southeast quadrant of Alameda Blvd. / San Pedro Dr. The study area includes the intersections of Alameda Blvd. / San Pedro Dr., Alameda Blvd. / I-25 E. Ramp, Alameda Blvd. / I-25 W. Ramp, Alameda Blvd. / San Mateo Blvd., Alameda Blvd. / Louisiana Blvd., and Signal Ave. / San Pedro Dr. as well as the proposed driveways for the project.

The proposed development is to be developed as a 25,000 S.F. rock climbing gym, 14,500 S.F. of retail commercial, and a 3,000 S.F. sit-down restaurant. The anticipated implementation year for this site is the year 2019. According to the Institute of Traffic Engineers' (ITE) trip generation rates, the weekday AM Peak Hour period is anticipated to generate approximately 50 entering trips and 48 exiting trips. During the weekday PM Peak Hour period, it is anticipated that it will generate approximately 135 entering trips and 96 exiting trips. It should be noted that local data was used for the rock climbing gym.

The development will be accessed via four proposed driveways: two on Alameda Blvd., one on San Pedro Dr. and one on Signal Ave. The driveways will be right-in / right-out only; the only exception is the one on Signal Ave., which will be full access.

Analysis results by analysis year are included in the following tables:

EXECUTIVE SUMMARY RESULTS TABLE

INTERSECTION NO. & NAME	SIGNALIZATION	2019 AM(PM) PEAK HOUR			2019 RECOMMENDATIONS
		NO BUILD	BUILD	MITIGATED	
1 - Alameda Blvd. / San Pedro Dr.	Signalized	C- 24.0 (B- 19.5)	C- 24.4 (C- 20.1)		No recommendation.
2 - Alameda Blvd. / I-25 East Ramp	Signalized	C- 29.2 (C- 28.0)	C- 29.2 (C- 28.5)		No Recommendation.
3 - Alameda Blvd. / I-25 West Ramp	Signalized	B- 14.9 (E- 63.3)	B- 14.9 (E- 63.4)		No recommendation.
4 - Alameda Blvd. / San Mateo Blvd.	Signalized	B- 10.6 (D- 44.8)	B- 10.7 (D- 45.3)		No recommendation.
5 - Alameda Blvd. / Louisiana Blvd.	Signalized	B- 19.7 (B- 16.9)	B- 19.8 (B- 17.0)		No Recommendation.
6 - Signal Ave. / San Pedro Dr.	Unsignalized	u- 1.4 (u- 2.5)	u- 2.1 (u- 4.1)		No Recommendation.
7 - Signal Ave. / Driveway "A"	Unsignalized	u- 0.0 (u- 0.0)	u- 2.4 (u- 3.1)		No Recommendation.
8 - Driveway "B" / San Pedro Dr.	Unsignalized	u- 0.0 (u- 0.0)	u- 0.1 (u- 0.2)		No recommendation.
9 - Alameda Blvd. / Driveway "C"	Unsignalized	u- 0.0 (u- 0.0)	u- 0.1 (u- 0.1)		No recommendation.
10 - Alameda Blvd. / Driveway "D"	Unsignalized	u- 0.0 (u- 0.0)	u- 0.1 (u- 0.1)		No recommendation.

EXECUTIVE SUMMARY RESULTS TABLE

INTERSECTION NO. & NAME	SIGNALIZATION	2029 AM(PM) PEAK HOUR			2029 RECOMMENDATIONS
		NO BUILD	BUILD	MITIGATED	
1 - Alameda Blvd. / San Pedro Dr.	Signalized	E- 55.9 (C- 25.3)	E- 55.9 (C- 26.7)		No recommendation.
2 - Alameda Blvd. / I-25 East Ramp	Signalized	C- 33.6 (C- 32.3)	C- 33.7 (C- 33.3)		No Recommendation.
3 - Alameda Blvd. / I-25 West Ramp	Signalized	B- 13.6 (F- 106)	B- 14.7 (F- 106)		No recommendation.
4 - Alameda Blvd. / San Mateo Blvd.	Signalized	B- 19.0 (E- 74.7)	B- 19.1 (E- 75.3)		No recommendation.
5 - Alameda Blvd. / Louisiana Blvd.	Signalized	C- 20.7 (B- 19.4)	C- 20.8 (B- 19.8)		No Recommendation.
6 - Signal Ave. / San Pedro Dr.	Unsignalized	u- 1.5 (u- 2.7)	u- 2.2 (u- 4.5)		No Recommendation.
7 - Signal Ave. / Driveway "A"	Unsignalized	u- 0.0 (u- 0.0)	u- 2.4 (u- 3.0)		No Recommendation.
8 - Driveway "B" / San Pedro Dr.	Unsignalized	u- 0.0 (u- 0.0)	u- 0.1 (u- 0.1)		No recommendation.
9 - Alameda Blvd. / Driveway "C"	Unsignalized	u- 0.0 (u- 0.0)	u- 0.0 (u- 0.1)		No recommendation.
10 - Alameda Blvd. / Driveway "D"	Unsignalized	u- 0.0 (u- 0.0)	u- 0.0 (u- 0.1)		No recommendation.

In summary, the proposed development does not have a significant adverse impact to the adjacent transportation system and the minimal impact to the transportation system can be mitigated by the recommended measures described in this report and summarized in the table above. In summary, the recommendations of this study are:

Recommendations:

- 1) Site improvements for the project shall maintain adequate site distances for the four driveways on the project as well as for the existing signalized intersection of Alameda Blvd. / San Pedro Dr.
- 2) Alameda Blvd. / San Pedro Dr. – the northbound left turn lane on San Pedro Dr. at Alameda Blvd. should be extended to the maximum length possible by narrowing the existing bulb in the raised median located approximately 150 feet south of the northbound stop bar on San Pedro Dr. at Alameda Blvd. In narrowing the bulb, the raised median should be maintained so that the width is approximately 4 feet to match the existing raised median to the north. This measure should extend the existing left turn lane length by at least 75 feet.
- 3) Driveway Guidelines:
 - a. Driveway "A" – a full access unsignalized driveway designed and constructed with one entering lane and one exiting lane minimum.

- b. Driveway “B” – a right-in, right-out only unsignalized driveway designed and constructed with one entering lane and one exiting lane minimum.
- c. Driveway “C” and Driveway “D” - right-in, right-out only unsignalized driveway designed and constructed with one entering lane and one exiting lane minimum.
- d. All driveways should be designed and constructed to accommodate delivery trucks for commercial uses.

**Alameda / San Pedro Development
(SE Corner)
Traffic Impact Study**

Contents

Executive Summaryi

Introduction 1

Description of Proposed Development 2

Study Area Conditions 3

Analysis of Existing Conditions 4

Analysis of Implementation Year Conditions 4

 Traffic Projections..... 4

 Traffic Analysis 8

Analysis of Horizon Year Conditions25

 Traffic Projections.....25

 Traffic Analysis26

 Impact Assessment35

 Access Design Specifications35

Summary of Deficiencies, Anticipated Impacts, and Recommendations36

APPENDIX.....39

Description of Proposed Development

The proposed project is described as a 25,000 S.F. rock climbing gym, 14,500 S.F. of retail commercial, and a 3,000 S.F. sit-down restaurant in the southeast quadrant of Alameda Blvd. / San Pedro Dr. The project lies in the city limits of Albuquerque, NM. The project fronts on a Regional Principal Arterial Roadway (Alameda Blvd.) which is maintained by the City of Albuquerque. The project is also close to the existing Alameda Blvd. / I-25 Interchange. Therefore, the project will be required to comply with the requirements of the City of Albuquerque with regard to the overall development, and with the requirements of the New Mexico Department of Transportation with regard to transportation issues near the Alameda Blvd. / I-25 Interchange and the existing signalize intersection of Alameda Blvd. / San Mateo Blvd..

This development will be constructed in one phase. This study will analyze an implementation year of 2019 and a horizon year of 2029.

The development will be accessed via four proposed driveways: two on Alameda Blvd., one on San Pedro Dr. and one on Signal Ave.

Following is the proposed site development plan depicting driveway (access) locations (also, see Appendix Page A-3 for a more complete version of the proposed site development plan):

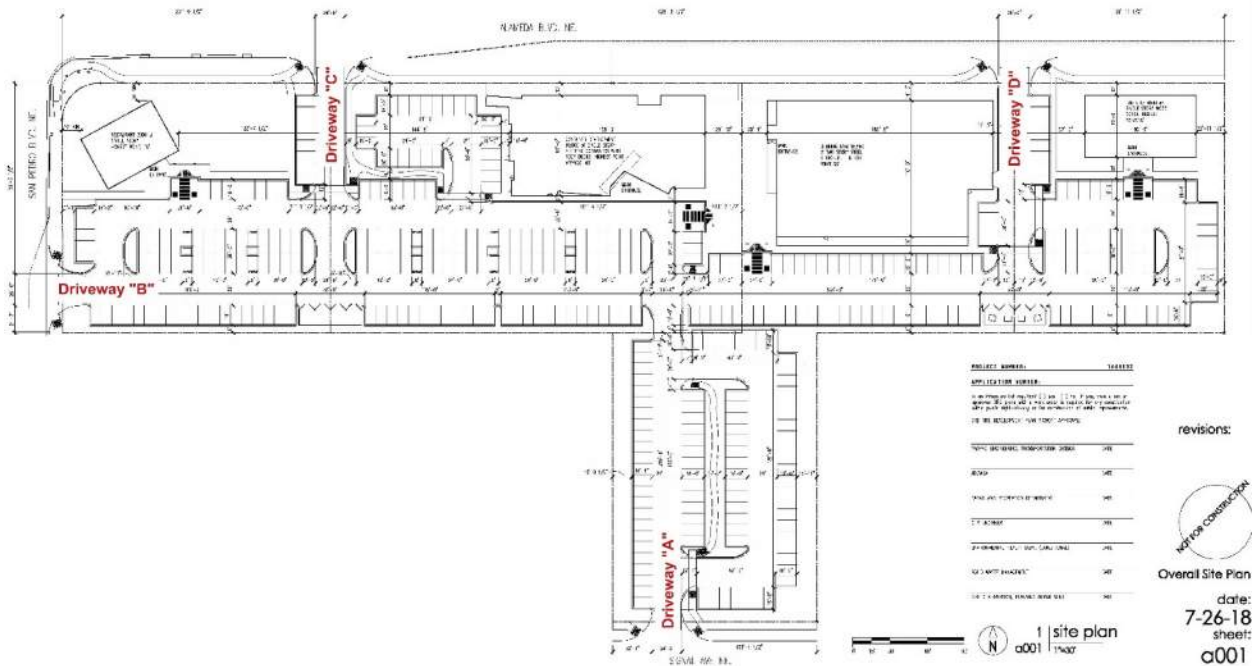

Study Area Conditions

A Traffic Impact Study Scoping Meeting was held on October 3, 2018 with the NMDOT (Nancy Perea) and City of Albuquerque (Ernest Armijo). During the exchange, it was determined that the study area would include the following list of intersections to be analyzed in the Traffic Impact Study:

1. Alameda Blvd. / San Pedro Dr.
2. Alameda Blvd. / I-25 East Ramp
3. Alameda Blvd. / I-25 West Ramp
4. Alameda Blvd. / San Mateo Blvd.
5. Alameda Blvd. / Louisiana Blvd.
6. Signal Ave. / San Pedro Dr.
7. Signal Ave. / Driveway "A"
8. Driveway "B" / San Pedro Dr.
9. Alameda Blvd. / Driveway "C"
10. Alameda Blvd. / Driveway "D"

This scope of study was based on the assumption that the parcel in question would be developed as a Retail / Commercial Development as shown on the proposed site plan.

There are no other known land development projects in the area which need to be incorporated into the background traffic model for this study. Also, there are no known Transportation Improvement Program projects in the area that need to be considered in the Traffic Impact Study.

This project is served by public transit services in the area; specifically Routes #31 and #98. Route 98 runs along Alameda Blvd. and then along Wyoming Blvd. Route #31 runs along Wyoming Blvd. and connects to Kirtland Air Force Base. See Appendix page A-155 for route map.

San Pedro Dr., Louisiana Blvd, & Alameda Blvd. are designated on the Futures 2040 Metropolitan Transportation Plan (2040 Long Range Bikeway System) as Proposed or Existing Bicycle Lanes. See Appendix page A-5 for a portion of the map.

There are pedestrian facilities in the project area – curb & gutter and sidewalks along the roads, as well as raised medians for pedestrians & bicyclists crossing against traffic.

Alameda Blvd. is classified as a Regional Principal Arterial Roadway. Alameda Blvd. is generally a four-lane divided highway with raised medians and curb & gutter with sidewalks. The posted speed limit along Alameda Blvd. is 35 MPH.

San Mateo Blvd., San Pedro Dr. and Louisiana Blvd. are classified as Major Collector Roadways on the Mid-Region Council of Government's Futures 2040 Long Range Roadway System Map. San Mateo Blvd. & San Pedro Dr. are two-lane roadways with curb & gutter with sidewalks. The posted speed limit along San Pedro Dr. is 35 MPH & along San Mateo Blvd. is 30 MPH.

Analysis of Existing Conditions

Due to the fact that the Implementation Year is only one year in the future, no existing analysis was performed. Existing traffic volumes (turning movement counts) were collected at the intersections targeted for analysis in this study in October 2018 and are included on Appendix Pages A-156 thru A-167. Traffic turning movements volumes at the Alameda Blvd. / I-25 East Ramp and the Alameda Blvd. / I-25 West Ramp were adjusted for demand based on drone videos collected during the traffic count periods for this project.

Analysis of Implementation Year Conditions

Traffic Projections

This study assumes that the development will be implemented in one phase with an implementation year of 2019.

Projected trips were calculated based on the Institute of Traffic Engineers (ITE) Trip Generation Manual (10th Edition) except for the Rock Climbing Gym use which utilized local trip generation data. Trips for the development were determined based on land use defined on the Conceptual Site Development Plan on Page A-3 in the Appendix of this report. The following table summarized the trip generation rate for the project:

Alameda / San Pedro Development (SE Corner)

Trip Generation Data (ITE Trip Generation Manual - 10th Edition)

USE (ITE CODE)	24 HR VOL	A. M. PEAK HR.		P. M. PEAK HR.		
		GROSS	ENTER	EXIT	ENTER	EXIT
DESCRIPTION						
Summary Sheet						
	Units					
High Turnover (Sit-Down) Restaurant (932)	3.00	337	16	13	18	11
Variety Store (814)	14.50	920	26	20	52	48
Rock Climbing Gym (Local Data)	25.00	-	8	15	65	37
Subtotal		1,257	50	48	135	96

Pass-by trips were not applied to this project. See Appendix Pages A-7 thru A-10 for more information regarding the trip generation.

The Gravity Model was used to determine trip distribution where primary trips for the commercial land use development were distributed proportionally to the 2019 projected population within a 2 ½ mile radius. Population data for the years 2012 and 2040 were taken from the 2040 Socioeconomic Forecasts by Subareas for the Mid-Region of New Mexico supplied by the Mid-Region Council of Governments (MRCOG). Population data from the years 2012 and 2040 was interpolated linearly to obtain 2019 population data to utilize for this analysis. Population Subzones were grouped based on the most likely major street(s) or route(s) to the subject development. The trip distribution worksheets and associated map of data analysis subzones are shown in the Appendix on Pages A-11 thru A-19. The commercial Trip Distribution map can be found below and in the Appendix on Page A-14.

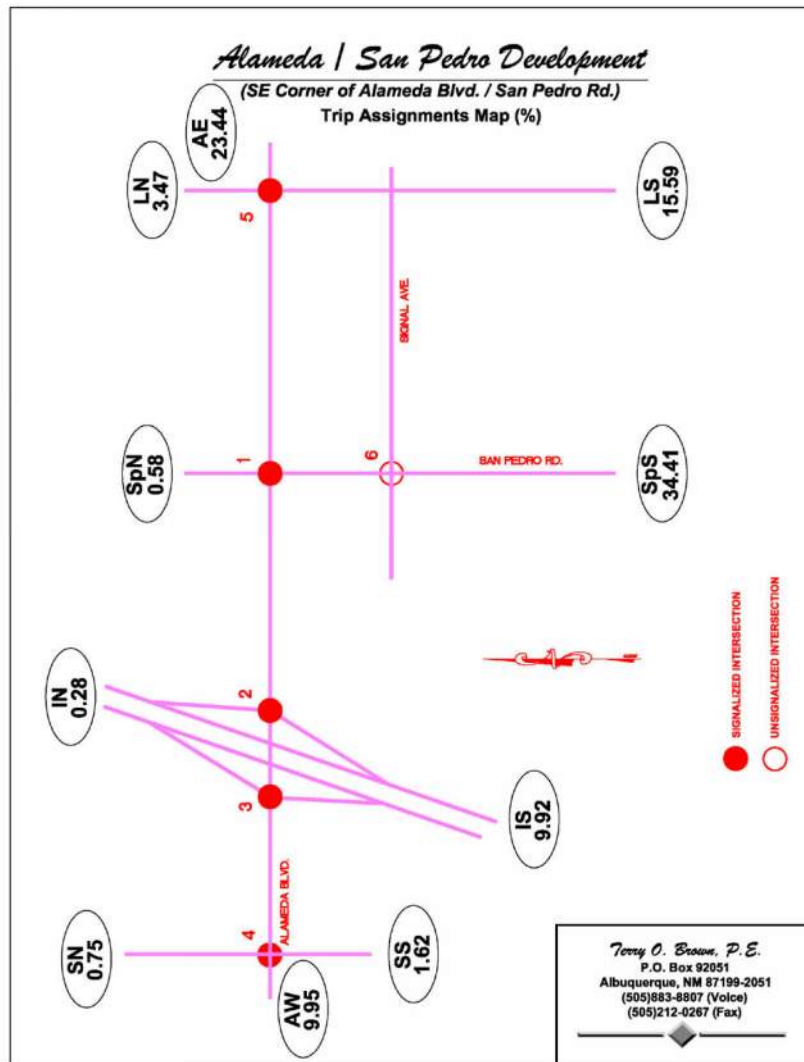

Trip assignments are first made on a percentage basis derived from data established in the trip distribution determination process and logical routing. Those percentages are then applied to the projected trips to determine individual traffic movements. Percentage trip assignments for commercial trips are shown below and in the Appendix on Pages A-15 thru A-16. No adjustments for pass-by trips on this project were applied.

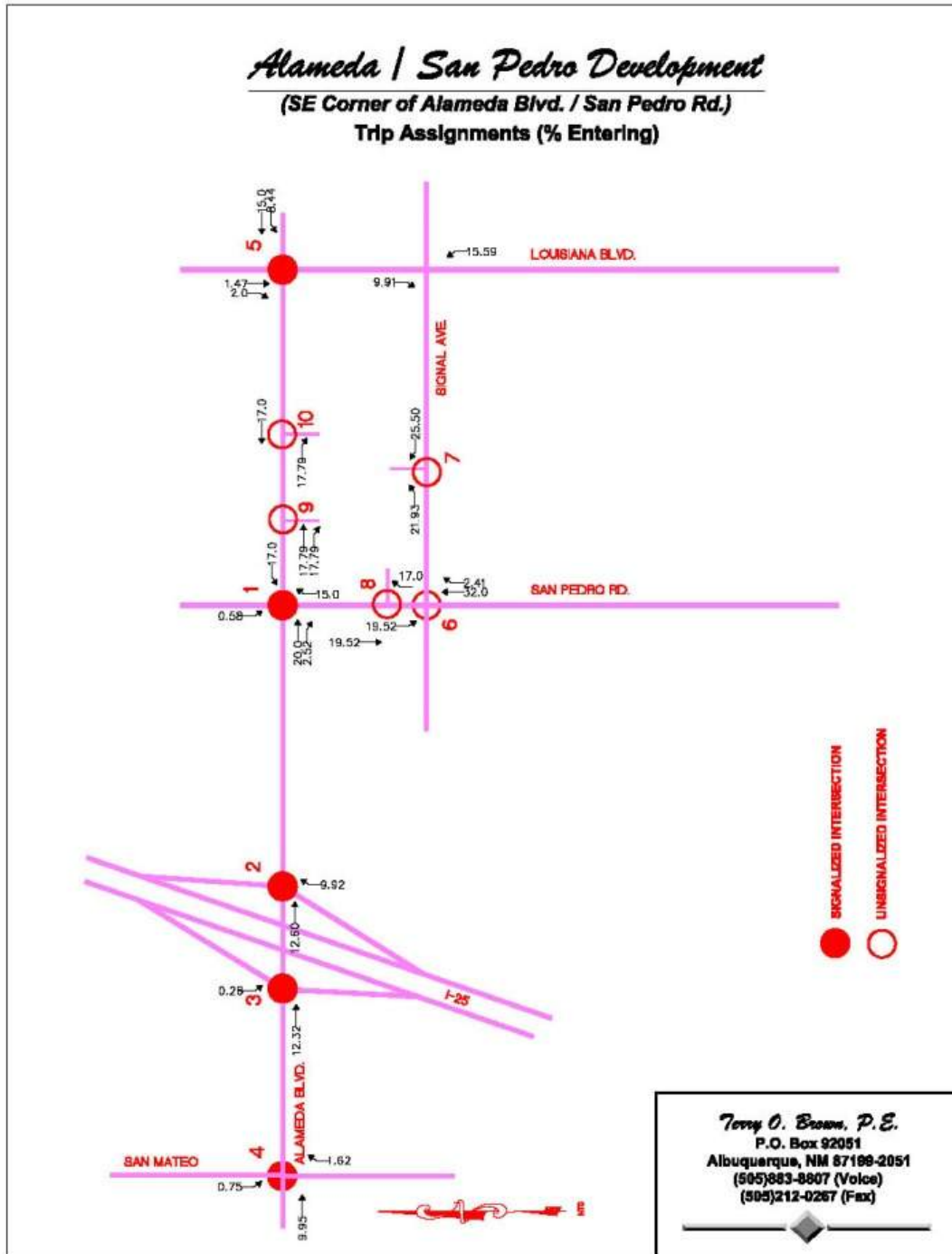

Alameda / San Pedro Development

(SE Corner of Alameda Blvd. / San Pedro Rd.)

Trip Assignments (% Exiting)

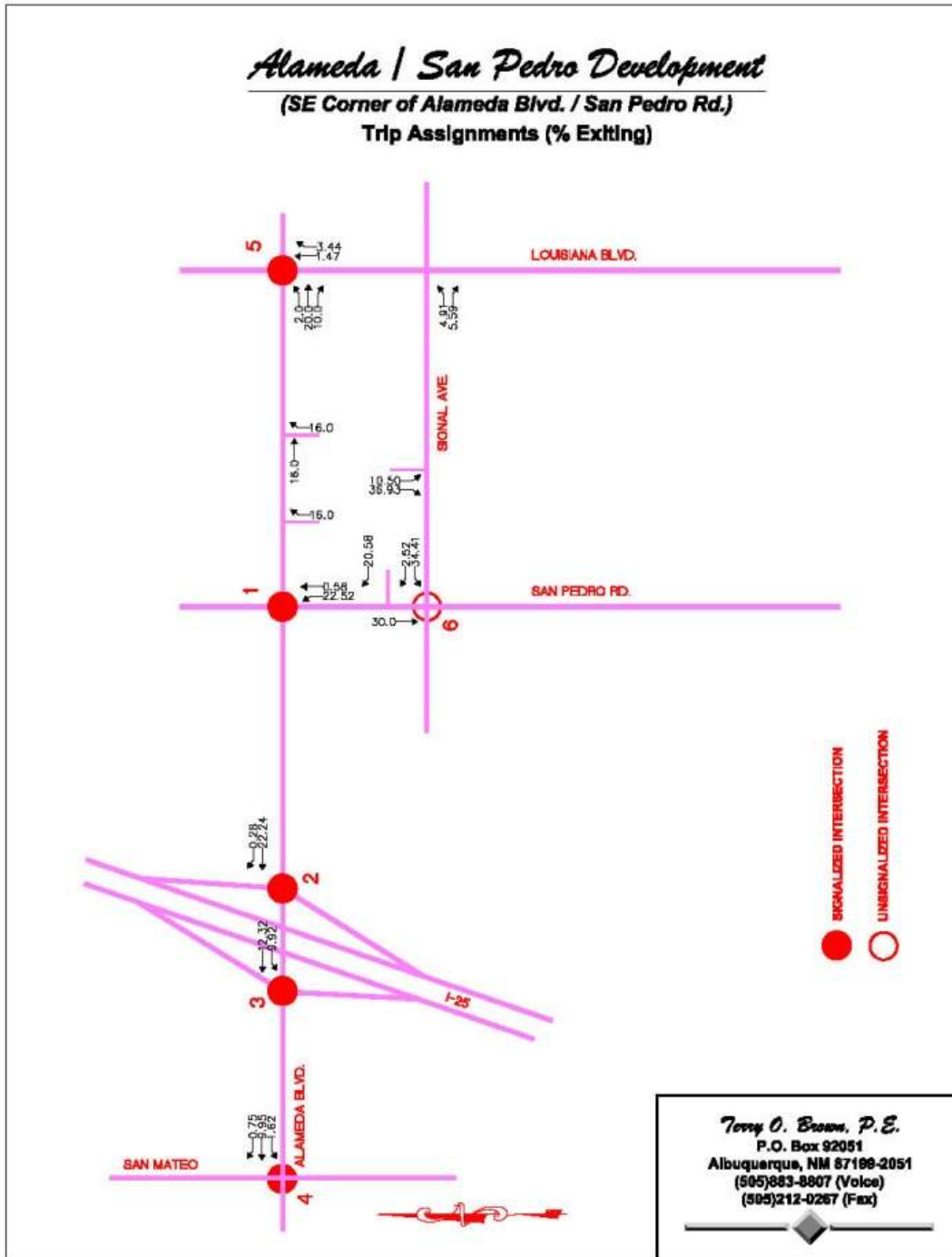

Background traffic growth rates were considered for each individual approach to an intersection that was targeted for analysis based on data from the 2008 through 2017 Traffic Flow maps prepared by the Mid-Region Council of Governments. Most of the Traffic Flow Data for those years taken from the MRCOG Traffic Flow Maps were Standard Data. The data from those

years for each approach was plotted on a graph and a linear “regression trend line” calculated using the equation format $y=mx+b$. The growth rate was determined by calculating the average volume increase per year during the time period considered and dividing that volume into the most recent AWDT used in the analysis from which future volumes will be calculated. The rate of growth of that trend line was utilized as the annual growth rate for each approach if that calculated rate appeared feasible. However, when a roadway segment considered in this analysis indicated either an inconsistent or a negative growth trend, then the growth rate was considered to be a generic 0.5%. Historical Growth Rate Graphs with linear regression trend lines are shown in the Appendix on Pages A-17 thru A-24. The growth rate utilized for each approach to an intersection is printed at the top of the Turning Movement sheets for each intersection (Appendix Pages A-25 thru A-47).

The trip generation, trip distribution and trip assignments were utilized along with the existing 2018 background traffic volumes and the historical traffic growth rates to determine the Implementation year NO BUILD and BUILD volumes, see Appendix Pages A-25 thru A-47. Implementation year AM Peak Hour and PM Peak Hour NO BUILD and BUILD volumes, intersection geometries (laneage), and calculated levels-of-service are displayed on the Lanes / Volumes / Analysis map located at the end of the front-end text of this report.

Traffic Analysis

A capacity analysis using existing traffic signal timing obtained from the City of Albuquerque Traffic Operations Division (see Appendix Pages A-71 thru A-102) was conducted for the Implementation Year (2019) AM and PM Peak Hour NO BUILD and BUILD Conditions. Analysis was conducted utilized Trafficware’s Synchro 10 software (version 10.3.15.0) which substantially complies with the methodology established in the Highway Capacity Manual, 6th Edition. A graphical summary of the Implementation Year conditions (i.e., Lane Geometry, 2019 NO BUILD and BUILD Volumes, and calculated levels-of-service associated with each lane group and each intersection) are displayed on the Lanes / Volumes / Analysis Maps at the end of the front-end text of this Study. The results are also summarized as follows:

#1 – Alameda Blvd. / San Pedro Dr. - Pages A-71 thru A-102

The results of the 2019 analyses of the signalized intersection of Alameda Blvd. / San Pedro Dr. are summarized in the following table:

Intersection: 1 - Alameda Blvd. / San Pedro Dr.

		<u>2019 AM Peak Hour</u>				<u>2019 PM Peak Hour</u>				
		(EXIST. GEOM.)				(EXIST. GEOM.)				
		NO BUILD		BUILD		NO BUILD		BUILD		
		Lanes	LOS-Delay	Lanes	LOS-Delay	Lanes	LOS-Delay	Lanes	LOS-Delay	
EB	L	1	B - 17.1	1	B - 17.4	L	1	B - 12.8	1	B - 13.2
	T	3	B - 18.4	3	B - 18.7	T	3	C - 21.0	3	C - 22.1
	R	>	B - 10.5	>	B - 10.4	R	>	B - 12.8	>	B - 12.6
WB	L	1	B - 13.7	1	B - 14.0	L	1	B - 14.1	1	B - 15.4
	T	2	C - 28.8	2	C - 29.4	T	2	B - 17.4	2	B - 17.8
	R	>	C - 28.6	>	C - 29.1	R	>	B - 17.3	>	B - 17.7
NB	L	1	C - 26.0	1	C - 26.8	L	1	C - 21.5	1	C - 22.4
	T	2	C - 23.2	2	C - 23.2	T	2	C - 22.8	2	C - 22.8
	R	>	C - 23.2	>	C - 23.3	R	>	C - 22.9	>	C - 23.4
SB	L	1	C - 25.2	1	C - 25.4	L	1	C - 22.2	1	C - 23.1
	T	2	C - 29.2	2	C - 29.5	T	2	C - 27.4	2	C - 28.3
	R	>	D - 36.7	>	D - 37.1	R	>	C - 33.3	>	C - 34.5
Intersection:		C - 24.0		C - 24.4		B - 19.5		C - 20.1		
Note: ">" designates a shared right or left turn lane.										
No recommendation.										

The 2019 analysis of the intersection of Alameda Blvd. / San Pedro Dr. demonstrates that the level-of-service will be acceptable for both the AM Peak Hour and PM Peak Hour NO BUILD and BUILD conditions analyzed in this report. The implementation of the proposed development increases the delay at the intersection by 0.4 seconds during the AM Peak Hour and by 0.6 seconds during the PM Peak Hour. Therefore, no recommendations are made for the intersection of Alameda Blvd. / San Pedro Dr.

The following table summarizes the results of the queuing analysis (95th Percentile confidence level) for the auxiliary lanes at the intersection:

Queueing Analysis Summary Sheet

Project: Alameda / San Pedro Development
 Intersection: Alameda Blvd. / San Pedro Dr.

2019											
Approach	Left Turns			Thru Movements			Right Turns				
Eastbound	# Lanes	Vol.	Length	# Lanes	Vol.	Length	# Lanes	Vol.	Length		
<i>Existing Lane Length</i>	1	71	150	2	428	Cont	1	292	325		
AM NO BUILD Queue	1	71	39	2	430	126	1	293	27		
AM BUILD Queue	1	71	39	2	440	130	1	294	28		
<i>Existing Lane Length</i>	1	94	150	2	881	Cont	1	424	325		
PM NO BUILD Queue	1	94	49	2	885	291	1	426	34		
PM BUILD Queue	1	94	49	2	912	308	1	429	34		
<hr/>											
Westbound	# Lanes	Vol.	Length	# Lanes	Vol.	Length	# Lanes	Vol.	Length		
<i>Existing Lane Length</i>	1	46	150	2	945	Cont	0	26	0		
AM NO BUILD Queue	1	47	28	2	962	347	0	26	347		
AM BUILD Queue	1	56	32	2	962	347	0	26	347		
<i>Existing Lane Length</i>	1	44	150	2	489	Cont	0	11	0		
PM NO BUILD Queue	1	45	28	2	498	160	0	11	160		
PM BUILD Queue	1	68	38	2	498	160	0	11	160		
<hr/>											
Northbound	# Lanes	Vol.	Length	# Lanes	Vol.	Length	# Lanes	Vol.	Length		
<i>Existing Lane Length</i>	1	311	100	2	61	Cont	0	30	0		
AM NO BUILD Queue	1	313	#263	2	61	39	0	30	38		
AM BUILD Queue	1	324	#279	2	61	40	0	38	40		
<i>Existing Lane Length</i>	1	229	100	2	56	Cont	0	57	0		
PM NO BUILD Queue	1	230	160	2	56	36	0	57	36		
PM BUILD Queue	1	252	178	2	57	38	0	77	38		
<hr/>											
Southbound	# Lanes	Vol.	Length	# Lanes	Vol.	Length	# Lanes	Vol.	Length		
<i>Existing Lane Length</i>	1	11	100	2	30	Cont	0	143	0		
AM NO BUILD Queue	1	11	85	2	31	40	0	149	40		
AM BUILD Queue	1	11	85	2	31	40	0	149	40		
<i>Existing Lane Length</i>	1	18	100	2	52	Cont	0	143	0		
PM NO BUILD Queue	1	19	21	2	54	47	0	149	47		
PM BUILD Queue	1	20	23	2	54	47	0	149	47		

NOTE: Queue Lengths are in feet.

Queue Lengths are 95th percentile confidence level.

Queue Lengths are based on Synchro 10 (HCM6) methodology.

~ Volume Exceeds Capacity. Queue is theoretically infinite.

(Queue shown is maximum after two cycles)

95th Percentile volume exceeds capacity, queue may be longer.

m Volume for 95th percentile queue is metered by upstream signal.

The queuing analysis demonstrates that the northbound left turn lane should be lengthened from 100 feet to 279 feet plus transition for both the NO BUILD and BUILD Conditions. The proposed Alameda / San Pedro Development is projected to increase the northbound left turn movement from 313 vehicles per hour to 324 vehicles per hour (an increase of 11 vehicles per hour) during the 2019 AM Peak Hour period. Similarly, the increase in the 2019 PM Peak Hour volume for the northbound left turn movement is increased from 230 vehicles per hour to 252 vehicles per hour (an increase of 22 vehicles per hour). The proposed Alameda / San Pedro Development does have an impact to the northbound left turn queue, but the calculated increase in queue length is only about 16 feet (less than one vehicle length). This report recommends that the northbound left turn lane, therefore, be extended by removing the bulb in the raised median on the south end of the south leg of San Pedro Dr. at Alameda Blvd. This action should provide an increase in the northbound left turn queuing by approximately 75 feet. In removing the bulb in the median, the raised median should not be shortened, but rather the bulb in the raised median should be narrowed to a width of approximately 4 feet (consistent with the width of the existing median to the north).

#2 – Alameda Blvd. / I-25 E. Ramp - Pages A-71 thru A-102

The results of the 2019 analyses of the full access signalized intersection of Alameda Blvd. / I-25 E. Ramp are summarized in the following table:

Intersection: 2 - Alameda Blvd. / I-25 East Ramp

		2019 AM Peak Hour				2019 PM Peak Hour				
		(EXIST. GEOM.)				(EXIST. GEOM.)				
		NO BUILD		BUILD		NO BUILD		BUILD		
		Lanes	LOS-Delay	Lanes	LOS-Delay	Lanes	LOS-Delay	Lanes	LOS-Delay	
EB	L	1	C - 23.2	1	C - 23.7	L	1	B - 19.9	1	C - 21.2
	T	2	A - 0.4	2	A - 0.4	T	2	A - 0.6	2	A - 0.6
	R		A - 0.0		A - 0.0	R		A - 0.0		A - 0.0
WB	L		A - 0.0		A - 0.0	L		A - 0.0		A - 0.0
	T	3	C - 23.8	3	C - 23.9	T	3	C - 27.7	3	C - 28.7
	R	>	C - 24.5	>	C - 24.6	R	>	C - 28.7	>	C - 29.7
NB	L	2	E - 55.8	2	E - 55.8	L	2	D - 46.3	2	D - 45.4
	T	2	C - 32.6	2	C - 32.6	T	2	D - 37.8	2	D - 37.1
	R	1	D - 37.0	1	D - 37.2	R	1	E - 73.3	1	E - 75.2
Intersection:		C - 29.2		C - 29.2		C - 28.0		C - 28.5		

Note: ">" designates a shared right or left turn lane.

No Recommendation.

The 2019 analysis of the intersection of Alameda Blvd. / I-25 E. Ramp demonstrates that the overall intersection delays will be acceptable for all conditions analyzed in this report. There is a

marginal level-of-service “E” for the northbound left turn movement during the 2019 AM Peak Hour (less than 1 second beyond level-of-service “D”) and level-of-service “E” for the northbound right turn movement during the 2019 PM Peak Hour period. The resulting level-of-service “E” is shown for both the 2019 AM NO BUILD and BUILD conditions and the 2019 PM NO BUILD and BUILD conditions. Additionally, it is demonstrated in the above table that the increase in overall intersection delay is increased by 0.0 seconds during that 2019 AM Peak Hour and 0.5 seconds during the 2019 PM Peak Hour as a result of the implementation of the Alameda / San Pedro Development. Thus, the impact of this proposed development is demonstrated to be minimal for this intersection. Therefore, no recommendations are made for the intersection of Alameda Blvd. / I-25 E. Ramp

It should be noted in the preceding table as well as the following queuing table that the existing geometric configuration of the northbound approach cannot be sufficiently represented due to limitations of the structures of the tables. The northbound intersection approach is comprised of an exclusive left turn lane, a thru / left turn lane, an exclusive thru lane, and an exclusive right turn lane.

The following table summarizes the results of the queuing analysis for the auxiliary lanes at the intersection:

Queueing Analysis Summary Sheet

Project: Alameda / San Pedro Development
 Intersection: Alameda Blvd. / I-25 E. Ramp

2019									
Approach	Left Turns			Thru Movements			Right Turns		
Eastbound	# Lanes	Vol.	Length	# Lanes	Vol.	Length	# Lanes	Vol.	Length
<i>Existing Lane Length</i>	1	202	180	2	641	Cont	0	0	0
AM NO BUILD Queue	1	203	#272	2	644	256	0	0	0
AM BUILD Queue	1	203	#222	2	650	261	0	0	0
<i>Existing Lane Length</i>	1	333	180	2	1,041	Cont	0	0	0
PM NO BUILD Queue	1	335	m217	2	1,046	m217	0	0	0
PM BUILD Queue	1	335	m227	2	1,063	m227	0	0	0
Westbound									
<i>Existing Lane Length</i>	0	0	0	3	1,208	Cont	0	157	0
AM NO BUILD Queue	0	0	0	3	1,214	400	0	158	400
AM BUILD Queue	0	0	0	3	1,225	405	0	158	405
<i>Existing Lane Length</i>	0	0	0	3	616	Cont	0	252	0
PM NO BUILD Queue	0	0	0	3	619	257	0	253	257
PM BUILD Queue	0	0	0	3	640	266	0	253	266
Northbound									
<i>Existing Lane Length</i>	2	933	750	1	73	Cont	1	209	999
AM NO BUILD Queue	2	938	#712	1	73	286	1	210	57
AM BUILD Queue	2	938	#712	1	73	286	1	215	58
<i>Existing Lane Length</i>	2	653	750	1	79	Cont	1	412	999
PM NO BUILD Queue	2	656	464	1	79	241	1	414	474
PM BUILD Queue	2	656	464	1	79	241	1	427	#507
Southbound									
<i>Existing Lane Length</i>	0	0	0	0	0	Cont	0	0	0
AM NO BUILD Queue	0	0	0	0	0	0	0	0	0
AM BUILD Queue	0	0	0	0	0	0	0	0	0
<i>Existing Lane Length</i>	0	0	0	0	0	Cont	0	0	0
PM NO BUILD Queue	0	0	0	0	0	0	0	0	0
PM BUILD Queue	0	0	0	0	0	0	0	0	0

NOTE: Queue Lengths are in feet.

Queue Lengths are 95th percentile confidence level.

Queue Lengths are based on Synchro 10 (HCM6) methodology.

~ Volume Exceeds Capacity. Queue is theoretically infinite.

(Queue shown is maximum after two cycles)

95th Percentile volume exceeds capacity, queue may be longer.

m Volume for 95th percentile queue is metered by upstream signal.

The queuing analysis demonstrates that the eastbound left turn lane should be lengthened from 180 feet to 272 feet plus transition for both the NO BUILD and BUILD Conditions. All other auxiliary lanes at the intersection are of sufficient length to accommodate the calculated 95th Percentile queues. The eastbound left turn lane cannot be extended since it would reduce the queue length of the complimentary westbound left turn lane at the I-25 West Ramp. Therefore, no recommendation is made.

#3 –Alameda Blvd. / I-25 W. Ramp – Pages A-71 thru A-102

The results of the analysis of the signalized intersection of Alameda Blvd. / I-25 W. Ramp are summarized in the following table:

Intersection: 3 - Alameda Blvd. / I-25 West Ramp

		<u>2019 AM Peak Hour</u>				<u>2019 PM Peak Hour</u>				
		(EXIST. GEOM.)				(EXIST. GEOM.)				
		NO BUILD		BUILD		NO BUILD		BUILD		
		Lanes	LOS-Delay	Lanes	LOS-Delay	Lanes	LOS-Delay	Lanes	LOS-Delay	
EB	L		A - 0.0		A - 0.0	L		A - 0.0	A - 0.0	
	T	2	A - 0.4	2	A - 0.4	T	2	D - 41.6	2	D - 42.3
	R	1	A - 2.4	1	A - 2.4	R	1	E - 67.8	1	E - 68.5
WB	L	2	D - 51.5	2	D - 51.6	L	2	E - 70.1	2	E - 70.5
	T	2	A - 0.6	2	A - 0.6	T	2	A - 0.5	2	A - 0.5
	R		A - 0.0		A - 0.0	R		A - 0.0		A - 0.0
SB	L	2	D - 53.9	2	D - 53.9	L	2	F - 141	2	F - 141
	T	2	E - 55.5	2	E - 55.5	T	2	F - 143	2	F - 143
	R	1	E - 64.0	1	E - 64.0	R	1	E - 56.1	1	E - 56.1
Intersection:		B - 14.9		B - 14.9		E - 63.3		E - 63.4		
Note: ">" designates a shared right or left turn lane.										
No recommendation.										

The 2019 analysis of the intersection of Alameda Blvd. / I-25 W. Ramp demonstrates that the delays will be acceptable for the 2019 AM Peak Hour Conditions, but not for the 2019 PM Peak Hour period. The southbound approach for the left turn and the thru movements are projected to operate at level-of-service “F”. Implementation of the proposed Alameda / San Pedro Development does not significantly impact the delays at this signalized intersection. As a result of this proposed development, the 2019 AM Peak Hour intersection delay is increased by 0.0 seconds and the 2019 PM Peak Hour intersection delays is increased by 0.1 seconds. Therefore, no recommendations are made for the intersection of Alameda Blvd. / I-25 W. Ramp.

The following table summarizes the results of the queuing analysis at the intersection:

Queueing Analysis Summary Sheet

Project: Alameda / San Pedro Development
 Intersection: Alameda Blvd. / I-25 W. Ramp

2019									
Approach	Left Turns			Thru Movements			Right Turns		
Eastbound	# Lanes	Vol.	Length	# Lanes	Vol.	Length	# Lanes	Vol.	Length
<i>Existing Lane Length</i>	0	0	0	2	658	Cont	1	513	350+
AM NO BUILD Queue	0	0	0	2	661	168	1	516	146
AM BUILD Queue	0	0	0	2	667	168	1	516	146
<i>Existing Lane Length</i>	0	0	0	2	952	Cont	1	747	350+
PM NO BUILD Queue	0	0	0	2	957	m481	1	751	m#952
PM BUILD Queue	0	0	0	2	974	m491	1	751	m#948
<hr/>									
Westbound	# Lanes	Vol.	Length	# Lanes	Vol.	Length	# Lanes	Vol.	Length
<i>Existing Lane Length</i>	2	509	220+	2	1,608	Cont	0	0	0
AM NO BUILD Queue	2	512	m249	2	1,616	m135	0	0	0
AM BUILD Queue	2	517	m249	2	1,622	m135	0	0	0
<i>Existing Lane Length</i>	2	294	220+	2	984	Cont	0	0	0
PM NO BUILD Queue	2	295	210	2	989	351	0	0	0
PM BUILD Queue	2	305	218	2	1,001	350	0	0	0
<hr/>									
Northbound	# Lanes	Vol.	Length	# Lanes	Vol.	Length	# Lanes	Vol.	Length
<i>Existing Lane Length</i>	0	0	0	0	0	Cont	0	0	0
AM NO BUILD Queue	0	0	0	0	0	0	0	0	0
AM BUILD Queue	0	0	0	0	0	0	0	0	0
<i>Existing Lane Length</i>	0	0	0	0	0	Cont	0	0	0
PM NO BUILD Queue	0	0	0	0	0	0	0	0	0
PM BUILD Queue	0	0	0	0	0	0	0	0	0
<hr/>									
Southbound	# Lanes	Vol.	Length	# Lanes	Vol.	Length	# Lanes	Vol.	Length
<i>Existing Lane Length</i>	2	204	715	1	120	Cont	1	149	170
AM NO BUILD Queue	2	205	160	1	121	140	1	150	147
AM BUILD Queue	2	205	160	1	121	140	1	150	147
<i>Existing Lane Length</i>	2	450	715	1	485	Cont	1	126	170
PM NO BUILD Queue	2	452	#632	1	487	#574	1	127	117
PM BUILD Queue	2	452	#632	1	487	#574	1	127	117

NOTE: Queue Lengths are in feet.

Queue Lengths are 95th percentile confidence level.

Queue Lengths are based on Synchro 10 (HCM6) methodology.

~ Volume Exceeds Capacity. Queue is theoretically infinite.

(Queue shown is maximum after two cycles)

95th Percentile volume exceeds capacity, queue may be longer.

m Volume for 95th percentile queue is metered by upstream signal.

Generally speaking, the existing auxiliary lanes at the Alameda Blvd. / I-25 West Ramp are of sufficient length to accommodate the calculated queues in the preceding table. The eastbound right turn lane is shown in the table as 350+ feet long. That, however, is the length of the eastbound right turn lane between the first driveway to the west and the I-25 West Ramp. In reality, the lane extends all the way to San Mateo Blvd. making it in excess of 1,000 feet of storage for the eastbound right turn movement. However, any queue greater than 350 feet will block one or more private driveways. Also, the westbound dual left turn lanes are shown as 220+ feet long. The outside left turn lane, however, extends beyond that length by a distance of approximately 250 feet. Therefore, it is apparent that there is sufficient total storage for the calculated 95th Percentile queue shown in the queuing table above. Therefore, no recommendation is made.

It should be noted in the preceding level-of-service table as well as the preceding queuing table that the existing geometric configuration of the southbound approach cannot be sufficiently represented due to limitations of the structures of the tables. The southbound intersection approach is comprised of an exclusive left turn lane, a thru / left turn lane, an exclusive thru lane, and an exclusive right turn lane

#4 – Alameda Blvd. / San Mateo Blvd. – Pages A-71 thru A-102

The results of the analysis of the full access signalized intersection of Alameda Blvd. / San Mateo Blvd. are summarized in the following table:

Intersection: 4 - Alameda Blvd. / San Mateo Blvd.

		2019 AM Peak Hour				2019 PM Peak Hour				
		(EXIST. GEOM.)				(EXIST. GEOM.)				
		NO BUILD		BUILD		NO BUILD		BUILD		
		Lanes LOS-Delay		Lanes LOS-Delay		Lanes LOS-Delay		Lanes LOS-Delay		
EB	L	1	A - 6.2	1	A - 6.2	L	1	B - 13.2	1	B - 13.3
	T	2	B - 10.7	2	B - 10.8	T	2	B - 19.5	2	B - 19.7
	R	>	B - 10.7	>	B - 10.7	R	>	B - 19.4	>	B - 19.6
WB	L	1	A - 6.8	1	A - 6.9	L	1	B - 14.0	1	B - 14.3
	T	2	A - 2.2	2	A - 2.3	T	2	C - 27.6	2	C - 27.8
	R	>	A - 2.8	>	A - 2.9	R	>	C - 27.6	>	C - 27.8
NB	L	1	D - 50.5	1	D - 50.4	L	1	F - 81.0	1	F - 81.0
	T	1	A - 0.0	1	A - 0.0	T	1	A - 0.0	1	A - 0.0
	R	>	D - 51.6	>	D - 51.6	R	>	D - 47.1	>	D - 47.2
SB	L	1	E - 61.4	1	E - 61.4	L	1	F - 153	1	F - 159
	T	1	A - 0.0	1	A - 0.0	T	1	A - 0.0	1	A - 0.0
	R	>	D - 48.1	>	D - 48.1	R	>	F - 101	>	F - 101
Intersection:		B - 10.6		B - 10.7		D - 44.8		D - 45.3		

Note: ">" designates a shared right or left turn lane.
No recommendation.

The 2019 analysis of the intersection of Alameda Blvd. / San Mateo Blvd. demonstrates that the delays will be acceptable for the 2019 AM Peak Hour period, but marginal for the 2019 PM Peak Hour period. As a result of this proposed development, the 2019 AM Peak Hour intersection delay is increased by 0.1 seconds and the 2019 PM Peak Hour intersection delays is increased by 0.5 seconds. Thus, it can be concluded that the proposed Alameda / San Pedro Development has no significant impact on the operation of the intersection of Alameda Blvd. / San Mateo Blvd. Therefore, no recommendations are made for the intersection of Alameda Blvd. / San Mateo Blvd.

The following table summarizes the results of the queuing analysis for the auxiliary lanes at the intersection:

Queueing Analysis Summary Sheet

Project: Alameda / San Pedro Development
 Intersection: Alameda Blvd. / San Mateo Blvd.

2019									
Approach	Left Turns			Thru Movements			Right Turns		
Eastbound	# Lanes	Vol.	Length	# Lanes	Vol.	Length	# Lanes	Vol.	Length
<i>Existing Lane Length</i>	1	260	253	2	1,027	Cont	0	28	0
AM NO BUILD Queue	1	261	58	2	1,032	295	0	28	295
AM BUILD Queue	1	261	60	2	1,037	298	0	28	298
<i>Existing Lane Length</i>	1	64	253	2	1,260	Cont	0	12	0
PM NO BUILD Queue	1	64	22	2	1,266	518	0	12	518
PM BUILD Queue	1	64	22	2	1,279	529	0	12	529
Westbound									
<i>Existing Lane Length</i>	1	77	150	2	900	Cont	0	585	0
AM NO BUILD Queue	1	77	m27	2	905	176	0	588	176
AM BUILD Queue	1	78	m27	2	910	176	0	588	176
<i>Existing Lane Length</i>	1	43	150	2	855	Cont	0	149	0
PM NO BUILD Queue	1	43	49	2	859	577	0	150	577
PM BUILD Queue	1	45	50	2	869	583	0	151	583
Northbound									
<i>Existing Lane Length</i>	1	15	75	1	84	Cont	0	63	0
AM NO BUILD Queue	1	15	33	1	84	168	0	63	168
AM BUILD Queue	1	15	33	1	84	169	0	64	169
<i>Existing Lane Length</i>	1	20	75	1	8	Cont	0	97	0
PM NO BUILD Queue	1	20	50	1	8	59	0	97	59
PM BUILD Queue	1	20	50	1	8	60	0	99	60
Southbound									
<i>Existing Lane Length</i>	1	74	310+	1	8	Cont	0	57	0
AM NO BUILD Queue	1	76	120	1	8	48	0	59	48
AM BUILD Queue	1	76	120	1	8	48	0	59	48
<i>Existing Lane Length</i>	1	278	310+	1	51	Cont	0	293	0
PM NO BUILD Queue	1	286	#544	1	52	320	0	301	320
PM BUILD Queue	1	287	#549	1	52	320	0	301	320

NOTE: Queue Lengths are in feet.

Queue Lengths are 95th percentile confidence level.

Queue Lengths are based on Synchro 10 (HCM6) methodology.

~ Volume Exceeds Capacity. Queue is theoretically infinite.

(Queue shown is maximum after two cycles)

95th Percentile volume exceeds capacity, queue may be longer.

m Volume for 95th percentile queue is metered by upstream signal.

The preceding queuing table demonstrates that the existing left turn auxiliary lanes are of sufficient lengths to accommodate the calculated 95th Percentile queues in this Study. It should be noted that the southbound left turn lane is much longer than the 310 feet shown in the table above, but beyond the 310 feet, the southbound left turn queue extends through the intersection of Larkspur Ln. with Alameda Blvd. No recommendation is made for the intersection of Alameda Blvd. / San Mateo Blvd. based on the queuing analysis.

#5 – Alameda Blvd. / Louisiana Blvd. - Pages A-71 thru A-102

The results of the 2019 analyses of the signalized intersection of Alameda Blvd. / Louisiana Blvd. are summarized in the following table:

Intersection: 5 - Alameda Blvd. / Louisiana Blvd.

		<u>2019 AM Peak Hour</u>				<u>2019 PM Peak Hour</u>				
		<u>(EXIST. GEOM.)</u>				<u>(EXIST. GEOM.)</u>				
		<u>NO BUILD</u>		<u>BUILD</u>		<u>NO BUILD</u>		<u>BUILD</u>		
		<u>Lanes</u>	<u>LOS-Delay</u>	<u>Lanes</u>	<u>LOS-Delay</u>	<u>Lanes</u>	<u>LOS-Delay</u>	<u>Lanes</u>	<u>LOS-Delay</u>	
EB	L	1	B - 13.4	1	B - 13.4	L	1	A - 9.4	1	A - 9.4
	T	2	B - 18.9	2	B - 19.0	T	2	B - 16.7	2	B - 16.8
	R	>	B - 19.0	>	B - 19.1	R	>	B - 16.7	>	B - 16.8
WB	L	1	B - 13.3	1	B - 13.4	L	1	B - 10.1	1	B - 10.3
	T	2	C - 20.7	2	C - 20.8	T	2	B - 13.3	2	B - 13.3
	R	>	C - 20.7	>	C - 20.7	R	>	B - 13.3	>	B - 13.3
NB	L	1	B - 16.7	1	B - 16.8	L	1	B - 19.8	1	C - 20.1
	T	2	B - 18.5	2	B - 18.6	T	2	C - 25.4	2	C - 25.8
	R	>	B - 18.6	>	B - 18.7	R	>	C - 25.9	>	C - 26.4
SB	L	1	B - 17.5	1	B - 17.6	L	1	B - 18.7	1	B - 19.1
	T	2	C - 24.9	2	C - 25.0	T	2	C - 25.0	2	C - 25.5
	R	>	C - 25.7	>	C - 25.8	R	>	C - 25.4	>	C - 26.0
Intersection:		B - 19.7		B - 19.8		B - 16.9		B - 17.0		
Note: ">" designates a shared right or left turn lane.										
No Recommendation.										

The 2019 analysis of the intersection of Alameda Blvd. / Louisiana Blvd. demonstrates that the level-of-service will be acceptable for both the AM Peak Hour and PM Peak Hour NO BUILD and BUILD conditions analyzed in this report. The implementation of the proposed development increases the delay at the intersection by 0.1 seconds during the AM Peak Hour and by 0.1 seconds during the PM Peak Hour. Therefore, no recommendations are made for the intersection of Alameda Blvd. / Louisiana Blvd.

The following table summarizes the results of the queuing analysis for the auxiliary lanes at the intersection:

Queueing Analysis Summary Sheet

Project: Alameda / San Pedro Development

Intersection: Alameda Blvd. / Louisiana Blvd.

2019									
Approach	Left Turns			Thru Movements			Right Turns		
Eastbound	# Lanes	Vol.	Length	# Lanes	Vol.	Length	# Lanes	Vol.	Length
<i>Existing Lane Length</i>	1	38	180	2	338	Cont	0	95	0
AM NO BUILD Queue	1	39	27	2	344	130	0	97	130
AM BUILD Queue	1	40	27	2	354	134	0	102	134
<i>Existing Lane Length</i>	1	110	180	2	697	Cont	0	144	0
PM NO BUILD Queue	1	112	52	2	710	250	0	147	250
PM BUILD Queue	1	114	53	2	729	264	0	157	264
Westbound									
<i>Existing Lane Length</i>	1	66	190	2	586	Cont	0	19	0
AM NO BUILD Queue	1	67	40	2	593	191	0	19	191
AM BUILD Queue	1	71	42	2	601	195	0	19	195
<i>Existing Lane Length</i>	1	41	190	2	396	Cont	0	26	0
PM NO BUILD Queue	1	41	24	2	401	123	0	26	123
PM BUILD Queue	1	52	29	2	421	130	0	26	130
Northbound									
<i>Existing Lane Length</i>	1	262	180	2	95	Cont	0	45	0
AM NO BUILD Queue	1	263	157	2	95	44	0	45	44
AM BUILD Queue	1	263	159	2	96	45	0	47	45
<i>Existing Lane Length</i>	1	106	180	2	103	Cont	0	53	0
PM NO BUILD Queue	1	107	77	2	104	52	0	53	52
PM BUILD Queue	1	107	78	2	105	52	0	56	52
Southbound									
<i>Existing Lane Length</i>	1	46	200	2	148	Cont	0	123	0
AM NO BUILD Queue	1	46	36	2	149	73	0	124	73
AM BUILD Queue	1	46	36	2	150	74	0	125	74
<i>Existing Lane Length</i>	1	37	200	2	91	Cont	0	45	0
PM NO BUILD Queue	1	37	34	2	91	50	0	45	50
PM BUILD Queue	1	37	34	2	93	51	0	48	51

NOTE: Queue Lengths are in feet.

Queue Lengths are 95th percentile confidence level.

Queue Lengths are based on Synchro 10 (HCM6) methodology.

~ Volume Exceeds Capacity. Queue is theoretically infinite.

(Queue shown is maximum after two cycles)

95th Percentile volume exceeds capacity, queue may be longer.

m Volume for 95th percentile queue is metered by upstream signal.

The preceding queuing table demonstrates that the existing left turn auxiliary lanes are of sufficient lengths to accommodate the calculated 95th Percentile queues in this Study. No recommendation is made for the intersection of Alameda Blvd. / San Mateo Blvd. based on the queuing analysis.

#6 – Signal Ave. / San Pedro Rd. - Pages A-71 thru A-102

The results of the 2019 analyses of the unsignalized intersection of Signal Ave. / San Pedro Rd. are summarized in the following tables:

Intersection: 6 - Signal Ave. / San Pedro Dr.

		2019 AM Peak Hour				2019 PM Peak Hour				
		(EXIST. GEOM.)				(EXIST. GEOM.)				
		NO BUILD		BUILD		NO BUILD		BUILD		
		Lanes	LOS-Delay	Lanes	LOS-Delay	Lanes	LOS-Delay	Lanes	LOS-Delay	
EB	L	>	C - 17.0	>	C - 17.9	L	>	C - 18.4	>	C - 20.9
	T	1	C - 17.0	1	C - 17.9	T	1	C - 18.4	1	C - 20.9
	R	>	C - 17.0	>	C - 17.9	R	>	C - 18.4	>	C - 20.9
WB	L	>	B - 13.5	1	C - 18.0	L	>	C - 16.6	1	D - 32.7
	T	1	B - 13.5	1	C - 18.0	T	1	C - 16.6	1	D - 32.7
	R	>	B - 13.5	>	C - 18.0	R	>	C - 16.6	>	D - 32.7
NB	L	>	A - 8.1	1	A - 8.1	L	>	A - 8.5	1	A - 8.5
	T	1	A - 0.0	1	A - 0.0	T	1	A - 0.0	1	A - 0.0
	R	>	A - 0.0	>	A - 0.0	R	>	A - 0.0	>	A - 0.0
SB	L	>	A - 8.3	>	A - 8.4	L	>	A - 8.1	>	A - 8.3
	T	1	A - 0.0	1	A - 0.0	T	1	A - 0.0	1	A - 0.0
	R	1	A - 0.0	>	A - 0.0	R	1	A - 0.0	>	A - 0.0
Intersection:		u - 1.4		u - 2.1		u - 2.5		u - 4.1		
Note: ">" designates a shared right or left turn lane. No Recommendation.										

The 2019 analysis of the intersection of Signal Ave. / San Pedro Rd. demonstrates that the level-of-service will be acceptable for both the AM Peak Hour and PM Peak Hour NO BUILD and BUILD conditions analyzed in this report. Therefore, no recommendations are made for the intersection of Signal Ave. / San Pedro Rd.

#7 – Signal Ave. / Driveway “A” - Pages A-71 thru A-102

The results of the 2019 analyses of the unsignalized intersection of Signal Ave. / Driveway “A” are summarized in the following tables:

Intersection: 7 - Signal Ave. / Driveway “A”

		2019 AM Peak Hour				2019 PM Peak Hour				
		(EXIST. GEOM.)		(EXIST. GEOM.)		(EXIST. GEOM.)		(EXIST. GEOM.)		
		NO BUILD		BUILD		NO BUILD		BUILD		
		Lanes	LOS-Delay	Lanes	LOS-Delay	Lanes	LOS-Delay	Lanes	LOS-Delay	
EB	L	>	A - 0.0	>	A - 7.4	L	>	A - 0.0	>	A - 7.4
	T	1	A - 0.0	>	A - 0.0	T	1	A - 0.0	>	A - 0.0
	R	>	A - 0.0	>	A - 0.0	R	>	A - 0.0	>	A - 0.0
WB	L	>	A - 0.0	>	A - 0.0	L	>	A - 0.0	>	A - 0.0
	T	1	A - 0.0	>	A - 0.0	T	1	A - 0.0	>	A - 0.0
	R	>	A - 0.0	>	A - 0.0	R	>	A - 0.0	>	A - 0.0
SB	L	>	A - 0.0	>	A - 8.8	L	>	A - 0.0	>	A - 9.0
	T	1	A - 0.0	>	A - 0.0	T	1	A - 0.0	>	A - 0.0
	R	>	A - 0.0	>	A - 8.8	R	>	A - 0.0	>	A - 9.0
Intersection:		u - 0.0		u - 2.4		u - 0.0		u - 3.1		
<p>Note: ">" designates a shared right or left turn lane.</p> <p>No Recommendation.</p>										

Driveway “A” is proposed as a full access driveway on Signal Ave. The 2019 analysis of the intersection of Signal Ave. / Driveway “A” demonstrates that the level-of-service will be acceptable for both the AM Peak Hour and PM Peak Hour NO BUILD and BUILD conditions analyzed in this report. Therefore, no recommendations are made for the intersection of Signal Ave. / Driveway “A”.

#8 – Driveway “B” / San Pedro Rd. - Pages A-71 thru A-102

The results of the 2019 analyses of the unsignalized intersection of Driveway “B” / San Pedro Rd. are summarized in the following tables:

Intersection: 8 - Driveway "B" / San Pedro Dr.

		<u>2019 AM Peak Hour</u>				<u>2019 PM Peak Hour</u>				
		<u>(EXIST. GEOM.)</u>				<u>(EXIST. GEOM.)</u>				
		<u>NO BUILD</u>		<u>BUILD</u>		<u>NO BUILD</u>		<u>BUILD</u>		
		<u>Lanes</u>	<u>LOS-Delay</u>	<u>Lanes</u>	<u>LOS-Delay</u>	<u>Lanes</u>	<u>LOS-Delay</u>	<u>Lanes</u>	<u>LOS-Delay</u>	
WB	L	>	A - 0.0	>	A - 0.0	L	>	A - 0.0	>	A - 0.0
	T	1	A - 0.0	>	A - 0.0	T	1	A - 0.0	>	A - 0.0
	R	>	A - 0.0	>	B - 11.4	R	>	A - 0.0	>	B - 10.7
NB	L		A - 0.0	>	A - 0.0	L	0	A - 0.0	>	A - 0.0
	T	1	A - 0.0	>	A - 0.0	T	1	A - 0.0	>	A - 0.0
	R	>	A - 0.0	>	A - 0.0	R	>	A - 0.0	>	A - 0.0
SB	L		A - 0.0	>	A - 0.0	L	0	A - 0.0	>	A - 0.0
	T	1	A - 0.0	>	A - 0.0	T	1	A - 0.0	>	A - 0.0
	R		A - 0.0	>	A - 0.0	R	0	A - 0.0	>	A - 0.0
Intersection:		u - 0.0		u - 0.1		u - 0.0		u - 0.2		
Note: ">" designates a shared right or left turn lane. No recommendation.										

Driveway “B” is proposed as a right-in, right-out only driveway on San Pedro Dr. The 2019 analysis of the intersection of Driveway “B” / San Pedro Rd. demonstrates that the level-of-service will be acceptable for both the AM Peak Hour and PM Peak Hour NO BUILD and BUILD conditions analyzed in this report. Therefore, no recommendations are made for the intersection of Driveway “B” / San Pedro Rd.

#9 – Alameda Blvd. / Driveway “C” - Pages A-71 thru A-102

The results of the 2019 analyses of the unsignalized intersection of Alameda Blvd. / Driveway “C” are summarized in the following table:

Intersection: 9 - Alameda Blvd. / Driveway "C"

		<u>2019 AM Peak Hour</u>				<u>2019 PM Peak Hour</u>				
		(EXIST. GEOM.)				(EXIST. GEOM.)				
		NO BUILD		BUILD		NO BUILD		BUILD		
		Lanes	LOS-Delay	Lanes	LOS-Delay	Lanes	LOS-Delay	Lanes	LOS-Delay	
EB	L		A - 0.0		A - 0.0	L		A - 0.0	A - 0.0	
	T	3	A - 0.0	3	A - 0.0	T	3	A - 0.0	3	A - 0.0
	R	>	A - 0.0	>	A - 0.0	R	>	A - 0.0	>	A - 0.0
WB	L		A - 0.0		A - 0.0	L		A - 0.0	A - 0.0	
	T	2	A - 0.0	2	A - 0.0	T	2	A - 0.0	2	A - 0.0
	R		A - 0.0		A - 0.0	R		A - 0.0	A - 0.0	
NB	L		A - 0.0		A - 0.0	L		A - 0.0	A - 0.0	
	T	1	A - 0.0	1	A - 0.0	T	1	A - 0.0	1	A - 0.0
	R	>	A - 0.0	>	B - 10.8	R	>	A - 0.0	>	B - 14.0
Intersection:		u - 0.0		u - 0.1		u - 0.0		u - 0.1		
Note: ">" designates a shared right or left turn lane. No recommendation.										

The 2019 analysis of the intersection of Alameda Blvd. / Driveway “C” demonstrates that the level-of-service will be acceptable for both the AM Peak Hour and PM Peak Hour NO BUILD and BUILD conditions analyzed in this report. Therefore, no recommendations are made for the intersection of Alameda Blvd. / Driveway “C”.

#10 – Alameda Blvd. / Driveway “D” - Pages A-71 thru A-102

The results of the 2019 analyses of the unsignalized intersection of Alameda Blvd. / Driveway “D” are summarized in the following tables:

Intersection: 10 - Alameda Blvd. / Driveway "D"

		<u>2019 AM Peak Hour</u>				<u>2019 PM Peak Hour</u>				
		(EXIST. GEOM.)				(EXIST. GEOM.)				
		NO BUILD		BUILD		NO BUILD		BUILD		
		Lanes	LOS-Delay	Lanes	LOS-Delay	Lanes	LOS-Delay	Lanes	LOS-Delay	
EB	L		A - 0.0		A - 0.0	L		A - 0.0		A - 0.0
	T	3	A - 0.0	3	A - 0.0	T	3	A - 0.0	3	A - 0.0
	R	>	A - 0.0	>	A - 0.0	R	>	A - 0.0	>	A - 0.0
WB	L		A - 0.0		A - 0.0	L		A - 0.0		A - 0.0
	T	2	A - 0.0	2	A - 0.0	T	2	A - 0.0	2	A - 0.0
	R		A - 0.0		A - 0.0	R		A - 0.0		A - 0.0
NB	L		A - 0.0		A - 0.0	L		A - 0.0		A - 0.0
	T	1	A - 0.0	1	A - 0.0	T	1	A - 0.0	1	A - 0.0
	R	>	A - 0.0	>	B - 10.8	R	>	A - 0.0	>	B - 13.9
Intersection:		u - 0.0		u - 0.1		u - 0.0		u - 0.1		
Note: ">" designates a shared right or left turn lane.										
No recommendation.										

The 2019 analysis of the intersection of Alameda Blvd. / Driveway “D” demonstrates that the level-of-service will be acceptable for both the AM Peak Hour and PM Peak Hour NO BUILD and BUILD conditions analyzed in this report. Therefore, no recommendations are made for the intersection of Alameda Blvd. / Driveway “D”.

Analysis of Horizon Year Conditions

Traffic Projections

This study will next evaluate the NO BUILD and BUILD conditions for the horizon year of 2029. The trip generation rate assumptions, the trip distribution assumptions, and the trip assignments of the new trips generated by the project were the same as that of the implementation year analysis. The major difference is that the current turning movements volumes were grown to the year 2029 based on the Mid-Region Council of Governments’ Regional Transportation Model forecasts.

Traffic Analysis

A capacity analysis using existing traffic signal timing obtained from the City of Albuquerque Traffic Operations Division (see Appendix Pages A-103 thru A-134) was conducted for the Horizon Year (2029) AM and PM Peak Hour NO BUILD and BUILD Conditions. Analysis was conducted utilizing Trafficware's Synchro 10 software (version 10.3.15.0) which substantially complies with the methodology established in the Highway Capacity Manual, 6th Edition. A graphical summary of the Horizon Year conditions (i.e., Lane Geometry, 2029 NO BUILD and BUILD Volumes, and calculated levels-of-service associated with each lane group and each intersection) are displayed on the Lanes / Volumes / Analysis Maps at the end of the front-end text of this Study. The results are also summarized as follows:

#1 – Alameda Blvd. / San Pedro Dr. - Pages A-103 thru A-134

The results of the 2029 analyses of the signalized intersection of Alameda Blvd. / San Pedro Dr. are summarized in the following table:

Intersection: 1 - Alameda Blvd. / San Pedro Dr.

		<u>2029 AM Peak Hour</u>				<u>2029 PM Peak Hour</u>				
		(EXIST. GEOM.)				(EXIST. GEOM.)				
		NO BUILD		BUILD		NO BUILD		BUILD		
		Lanes	LOS-Delay	Lanes	LOS-Delay	Lanes	LOS-Delay	Lanes	LOS-Delay	
EB	L	1	C - 24.1	1	C - 24.1	L	1	B - 16.5	1	B - 17.1
	T	3	C - 22.0	3	C - 22.1	T	3	C - 29.4	3	C - 32.0
	R	>	B - 13.6	>	B - 13.6	R	>	B - 17.4	>	B - 17.2
WB	L	1	B - 16.9	1	B - 17.2	L	1	B - 19.4	1	C - 21.4
	T	2	F - 95.5	2	F - 95.5	T	2	C - 22.3	2	C - 23.1
	R	>	F - 95.7	>	F - 95.7	R	>	C - 22.3	>	C - 23.0
NB	L	1	D - 37.1	1	D - 40.6	L	1	C - 25.2	1	C - 27.4
	T	2	C - 22.4	2	C - 22.4	T	2	C - 22.9	2	C - 22.8
	R	>	C - 22.5	>	C - 22.5	R	>	C - 23.0	>	C - 23.3
SB	L	1	C - 25.6	1	C - 25.6	L	1	C - 23.4	1	C - 24.2
	T	2	C - 30.3	2	C - 30.3	T	2	C - 28.7	2	C - 29.4
	R	>	D - 45.1	>	D - 45.1	R	>	D - 39.3	>	D - 40.9
Intersection:		E - 55.9		E - 55.9		C - 25.3		C - 26.7		
Note: ">" designates a shared right or left turn lane.										
No recommendation.										

The 2029 analysis of the intersection of Alameda Blvd. / San Pedro Dr. demonstrates that the level-of-service will be acceptable for the PM Peak Hour NO BUILD and BUILD conditions analyzed in this report. The 2029 AM Peak Hour analysis projects a long delay to occur for the

westbound thru and right turn movements. The overall intersection delay at this intersection for the AM Peak Hour is not significantly impacted by this project. The calculated increase in delay is 0.0 seconds for the 2029 AM Peak Hour and 1.4 seconds for the 2029 PM Peak Hour. Therefore, no recommendations are made for the intersection of Alameda Blvd. / San Pedro Dr.

#2 – Alameda Blvd. / I-25 E. Ramp - Pages A-103 thru A-134

The results of the 2029 analyses of the full access signalized intersection of Alameda Blvd. / I-25 E. Ramp are summarized in the following table:

Intersection: 2 - Alameda Blvd. / I-25 East Ramp

		<u>2029 AM Peak Hour</u>				<u>2029 PM Peak Hour</u>				
		(EXIST. GEOM.)				(EXIST. GEOM.)				
		NO BUILD		BUILD		NO BUILD		BUILD		
		Lanes	LOS-Delay	Lanes	LOS-Delay	Lanes	LOS-Delay	Lanes	LOS-Delay	
EB	L	1	E - 61.0	1	E - 61.3	L	1	E - 62.9	1	E - 69.2
	T	2	A - 0.5	2	A - 0.5	T	2	A - 0.6	2	A - 0.6
	R		A - 0.0		A - 0.0	R		A - 0.0		A - 0.0
WB	L		A - 0.0		A - 0.0	L		A - 0.0		A - 0.0
	T	3	C - 30.5	3	C - 30.7	T	3	C - 32.0	3	C - 32.8
	R	>	C - 31.0	>	C - 31.2	R	>	C - 33.2	>	C - 34.1
NB	L	2	E - 58.4	2	E - 58.4	L	2	D - 45.7	2	D - 45.0
	T	2	C - 31.9	2	C - 31.9	T	2	D - 36.8	2	D - 36.3
	R	1	D - 36.4	1	D - 36.6	R	1	E - 76.4	1	E - 79.2
SB	L		A - 0.0		A - 0.0	L		A - 0.0		A - 0.0
	T		A - 0.0		A - 0.0	T		A - 0.0		A - 0.0
	R		A - 0.0		A - 0.0	R		A - 0.0		A - 0.0
Intersection:		C - 33.6		C - 33.7		C - 32.3		C - 33.3		

Note: ">" designates a shared right or left turn lane.
No Recommendation.

The 2029 analysis of the intersection of Alameda Blvd. / I-25 E. Ramp demonstrates that the overall intersection delays will be acceptable for all conditions analyzed in this report. There are some turning movements that are projected to operate at level-of-service “E” in 2029, but none at level-of-service “F”. Additionally, it is demonstrated in the above table that the increase in overall intersection delay is increased by 0.1 seconds during that 2029 AM Peak Hour and 1.0 seconds during the 2029 PM Peak Hour as a result of the implementation of the Alameda / San Pedro Development. Thus, the impact of this proposed development is demonstrated to be minimal for this intersection. Therefore, no recommendations are made for the intersection of Alameda Blvd. / I-25 E. Ramp

It should be noted in the preceding table as well as the following queuing table that the existing geometric configuration of the northbound approach cannot be sufficiently represented due to limitations of the structures of the tables. The northbound intersection approach is comprised of an exclusive left turn lane, a thru / left turn lane, an exclusive thru lane, and an exclusive right turn lane.

#3 –Alameda Blvd. / I-25 W. Ramp – Pages A-103 thru A-134

The results of the analysis of the signalized intersection of Alameda Blvd. / I-25 W. Ramp are summarized in the following table:

Intersection: 3 - Alameda Blvd. / I-25 West Ramp

		2029 AM Peak Hour				2029 PM Peak Hour				
		(EXIST. GEOM.)				(EXIST. GEOM.)				
		NO BUILD		BUILD		NO BUILD		BUILD		
		Lanes	LOS-Delay	Lanes	LOS-Delay	Lanes	LOS-Delay	Lanes	LOS-Delay	
EB	L		A - 0.0		A - 0.0	L		A - 0.0		A - 0.0
	T	2	A - 0.4	2	A - 0.5	T	2	D - 47.2	2	D - 47.8
	R	1	A - 3.3	1	A - 3.7	R	1	F - 145	1	F - 148
WB	L	2	D - 48.9	2	D - 49.0	L	2	E - 69.9	2	E - 70.2
	T	2	A - 0.5	2	A - 0.6	T	2	A - 0.5	2	A - 0.5
	R		A - 0.0		A - 0.0	R		A - 0.0		A - 0.0
NB	L		A - 0.0		A - 0.0	L		A - 0.0		A - 0.0
	T		A - 0.0		A - 0.0	T		A - 0.0		A - 0.0
	R		A - 0.0		A - 0.0	R		A - 0.0		A - 0.0
SB	L	2	D - 53.1	2	D - 52.7	L	2	F - 232	2	F - 232
	T	2	E - 55.6	2	D - 54.3	T	2	F - 244	2	F - 244
	R	1	E - 64.4	1	E - 66.3	R	1	E - 59.5	1	E - 59.5
Intersection:		B - 13.6		B - 14.7		F - 106		F - 106		
Note: ">" designates a shared right or left turn lane.										
No recommendation.										

The 2029 analysis of the intersection of Alameda Blvd. / I-25 W. Ramp demonstrates that the delays will be acceptable for the 2029 AM Peak Hour Conditions, but not for the 2029 PM Peak Hour period. The southbound approach for the left turn and the thru movements are projected to operate at level-of-service "F". Implementation of the proposed Alameda / San Pedro Development does not significantly impact the delays at this signalized intersection. As a result of this proposed development, the 2029 AM Peak Hour intersection delay is increased by 1.1 seconds and the 2029 PM Peak Hour intersection delays is increased by 0.1 seconds (increase not indicated in table above since delays is rounded). Therefore, no recommendations are made for the intersection of Alameda Blvd. / I-25 W. Ramp.

It should be noted in the preceding level-of-service table that the existing geometric configuration of the southbound approach cannot be sufficiently represented due to limitations of the structure of the table. The southbound intersection approach is comprised of an exclusive left turn lane, a thru / left turn lane, an exclusive thru lane, and an exclusive right turn lane

#4 – Alameda Blvd. / San Mateo Blvd. – Pages A-103 thru A-134

The results of the analysis of the full access signalized intersection of Alameda Blvd. / San Mateo Blvd. are summarized in the following table:

Intersection: 4 - Alameda Blvd. / San Mateo Blvd.

		<u>2029 AM Peak Hour</u>				<u>2029 PM Peak Hour</u>				
		(EXIST. GEOM.)				(EXIST. GEOM.)				
		NO BUILD		BUILD		NO BUILD		BUILD		
		Lanes	LOS-Delay	Lanes	LOS-Delay	Lanes	LOS-Delay	Lanes	LOS-Delay	
EB	L	1	A - 7.8	1	A - 7.8	L	1	B - 14.0	1	B - 14.1
	T	2	B - 13.1	2	B - 13.1	T	2	C - 25.1	2	C - 25.5
	R	>	B - 13.0	>	B - 13.1	R	>	C - 25.0	>	C - 25.3
WB	L	1	A - 8.7	1	A - 8.8	L	1	C - 20.7	1	C - 21.3
	T	2	A - 3.4	2	A - 3.3	T	2	C - 28.3	2	C - 28.5
	R	>	A - 5.4	>	A - 5.3	R	>	C - 28.4	>	C - 28.5
NB	L	1	D - 51.0	1	D - 51.0	L	1	F - 109	1	F - 109
	T	1	A - 0.0	1	A - 0.0	T	1	A - 0.0	1	A - 0.0
	R	>	E - 56.5	>	E - 56.7	R	>	D - 49.3	>	D - 49.4
SB	L	1	F - 177	1	F - 179	L	1	F - 367	1	F - 374
	T	1	A - 0.0	1	A - 0.0	T	1	A - 0.0	1	A - 0.0
	R	>	D - 46.8	>	D - 46.8	R	>	F - 162	>	F - 162
Intersection:		B - 19.0		B - 19.1		E - 74.7		E - 75.3		

Note: ">" designates a shared right or left turn lane.
No recommendation.

The 2029 analysis of the intersection of Alameda Blvd. / San Mateo Blvd. demonstrates that the overall delays will be acceptable for the 2029 AM Peak Hour period, but marginal for the 2029 PM Peak Hour period. As a result of this proposed development, the 2029 AM Peak Hour intersection delay is increased by 0.1 seconds and the 2029 PM Peak Hour intersection delays is increased by 0.6 seconds. Thus, it can be concluded that the proposed Alameda / San Pedro Development has no significant impact on the operation of the intersection of Alameda Blvd. / San Mateo Blvd. Therefore, no recommendations are made for the intersection of Alameda Blvd. / San Mateo Blvd.

#5 – Alameda Blvd. / Louisiana Blvd. - Pages A-103 thru A-134

The results of the 2029 analyses of the signalized intersection of Alameda Blvd. / Louisiana Blvd. are summarized in the following table:

Intersection: 5 - Alameda Blvd. / Louisiana Blvd.

		<u>2029 AM Peak Hour</u>				<u>2029 PM Peak Hour</u>				
		(EXIST. GEOM.)				(EXIST. GEOM.)				
		NO BUILD		BUILD		NO BUILD		BUILD		
		Lanes	LOS-Delay	Lanes	LOS-Delay	Lanes	LOS-Delay	Lanes	LOS-Delay	
EB	L	1	B - 14.2	1	B - 14.2	L	1	A - 9.3	1	A - 9.3
	T	2	C - 20.6	2	C - 20.8	T	2	C - 20.2	2	C - 21.0
	R	>	C - 20.7	>	C - 20.9	R	>	C - 20.4	>	C - 21.2
WB	L	1	B - 14.2	1	B - 14.3	L	1	B - 11.4	1	B - 11.9
	T	2	C - 21.7	2	C - 21.7	T	2	B - 12.7	2	B - 12.8
	R	>	C - 21.6	>	C - 21.7	R	>	B - 12.7	>	B - 12.8
NB	L	1	B - 16.9	1	B - 17.0	L	1	C - 23.1	1	C - 23.4
	T	2	B - 18.4	2	B - 18.5	T	2	C - 28.2	2	C - 28.5
	R	>	B - 18.5	>	B - 18.6	R	>	C - 28.7	>	C - 29.0
SB	L	1	B - 18.0	1	B - 18.1	L	1	C - 22.4	1	C - 22.7
	T	2	C - 25.7	2	C - 25.8	T	2	C - 29.6	2	C - 30.0
	R	>	C - 26.5	>	C - 26.6	R	>	C - 30.3	>	C - 30.8
Intersection:		C - 20.7		C - 20.8		B - 19.4		B - 19.8		
Note: ">" designates a shared right or left turn lane.										
No Recommendation.										

The 2029 analysis of the intersection of Alameda Blvd. / Louisiana Blvd. demonstrates that the level-of-service will be acceptable for both the AM Peak Hour and PM Peak Hour NO BUILD and BUILD conditions analyzed in this report. The implementation of the proposed development increases the delay at the intersection by 0.1 seconds during the AM Peak Hour and by 0.4 seconds during the PM Peak Hour. Therefore, no recommendations are made for the intersection of Alameda Blvd. / Louisiana Blvd.

#6 – Signal Ave. / San Pedro Rd. - Pages A-103 thru A-134

The results of the 2029 analyses of the unsignalized intersection of Signal Ave. / San Pedro Rd. are summarized in the following tables:

Intersection: 6 - Signal Ave. / San Pedro Dr.

		<u>2029 AM Peak Hour</u>				<u>2029 PM Peak Hour</u>				
		(EXIST. GEOM.)				(EXIST. GEOM.)				
		NO BUILD		BUILD		NO BUILD		BUILD		
		Lanes	LOS-Delay	Lanes	LOS-Delay	Lanes	LOS-Delay	Lanes	LOS-Delay	
EB	L	>	C - 17.9	>	C - 18.9	L	>	C - 19.9	>	C - 22.7
	T	1	C - 17.9	1	C - 18.9	T	1	C - 19.9	1	C - 22.7
	R	>	C - 17.9	>	C - 18.9	R	>	C - 19.9	>	C - 22.7
WB	L	>	B - 13.9	1	C - 18.8	L	>	C - 17.5	1	E - 36.8
	T	1	B - 13.9	1	C - 18.8	T	1	C - 17.5	1	E - 36.8
	R	>	B - 13.9	>	C - 18.8	R	>	C - 17.5	>	E - 36.8
NB	L	>	A - 8.2	1	A - 8.2	L	>	A - 8.6	1	A - 8.6
	T	1	A - 0.0	1	A - 0.0	T	1	A - 0.0	1	A - 0.0
	R	>	A - 0.0	>	A - 0.0	R	>	A - 0.0	>	A - 0.0
SB	L	>	A - 8.4	>	A - 8.5	L	>	A - 8.1	>	A - 8.4
	T	1	A - 0.0	1	A - 0.0	T	1	A - 0.0	1	A - 0.0
	R	1	A - 0.0	>	A - 0.0	R	1	A - 0.0	>	A - 0.0
Intersection:		u - 1.5		u - 2.2		u - 2.7		u - 4.5		

Note: ">" designates a shared right or left turn lane.
No Recommendation.

The 2029 analysis of the intersection of Signal Ave. / San Pedro Rd. demonstrates that the level-of-service will be acceptable for both the AM Peak Hour and PM Peak Hour NO BUILD and BUILD conditions analyzed in this report. The westbound approach is at level-of-service “E” with an average control delay of 36.8 seconds (only 1.8 seconds more than the upper threshold of level-of-service “D”). Therefore, no recommendations are made for the intersection of Signal Ave. / San Pedro Rd.

#8 – Driveway “B” / San Pedro Rd. - Pages A-103 thru A-134

The results of the 2029 analyses of the unsignalized intersection of Driveway “B” / San Pedro Rd. are summarized in the following tables:

Intersection: 8 - Driveway "B" / San Pedro Dr.

		<u>2029 AM Peak Hour</u>				<u>2029 PM Peak Hour</u>				
		(EXIST. GEOM.)				(EXIST. GEOM.)				
		NO BUILD		BUILD		NO BUILD		BUILD		
		Lanes	LOS-Delay	Lanes	LOS-Delay	Lanes	LOS-Delay	Lanes	LOS-Delay	
WB	L	>	A - 0.0	>	A - 0.0	L	>	A - 0.0	>	A - 0.0
	T	1	A - 0.0	>	A - 0.0	T	1	A - 0.0	>	A - 0.0
	R	>	A - 0.0	>	B - 11.6	R	>	A - 0.0	>	B - 10.8
NB	L		A - 0.0	>	A - 0.0	L	0	A - 0.0	>	A - 0.0
	T	1	A - 0.0	>	A - 0.0	T	1	A - 0.0	>	A - 0.0
	R	>	A - 0.0	>	B - 11.4	R	>	A - 0.0	>	C - 15.2
SB	L		A - 0.0	>	A - 0.0	L	0	A - 0.0	>	A - 0.0
	T	1	A - 0.0	>	A - 0.0	T	1	A - 0.0	>	A - 0.0
	R		A - 0.0	>	A - 0.0	R	0	A - 0.0	>	A - 0.0
Intersection:		<i>u - 0.0</i>		<i>u - 0.1</i>		<i>u - 0.0</i>		<i>u - 0.1</i>		

Note: ">" designates a shared right or left turn lane.

No recommendation.

Driveway “B” is proposed as a right-in, right-out only driveway on San Pedro Dr. The 2029 analysis of the intersection of Driveway “B” / San Pedro Rd. demonstrates that the level-of-service will be acceptable for both the AM Peak Hour and PM Peak Hour NO BUILD and BUILD conditions analyzed in this report.. Therefore, no recommendations are made for the intersection of Driveway “B” / San Pedro Rd.

#9 – Alameda Blvd. / Driveway “C” - Pages A-103 thru A-134

The results of the 2029 analyses of the unsignalized intersection of Alameda Blvd. / Driveway “C” are summarized in the following table:

Intersection: 9 - Alameda Blvd. / Driveway "C"

		<u>2029 AM Peak Hour</u>				<u>2029 PM Peak Hour</u>				
		(EXIST. GEOM.)				(EXIST. GEOM.)				
		NO BUILD		BUILD		NO BUILD		BUILD		
		Lanes	LOS-Delay	Lanes	LOS-Delay	Lanes	LOS-Delay	Lanes	LOS-Delay	
EB	L		A - 0.0		A - 0.0	L		A - 0.0		A - 0.0
	T	3	A - 0.0	3	A - 0.0	T	3	A - 0.0	3	A - 0.0
	R	>	A - 0.0	>	A - 0.0	R	>	A - 0.0	>	A - 0.0
WB	L		A - 0.0		A - 0.0	L		A - 0.0		A - 0.0
	T	2	A - 0.0	2	A - 0.0	T	2	A - 0.0	2	A - 0.0
	R		A - 0.0		A - 0.0	R		A - 0.0		A - 0.0
NB	L		A - 0.0		A - 0.0	L		A - 0.0		A - 0.0
	T	1	A - 0.0	1	A - 0.0	T	1	A - 0.0	1	A - 0.0
	R	>	A - 0.0	>	B - 11.4	R	>	A - 0.0	>	C - 15.2
Intersection:		<i>u</i> - 0.0		<i>u</i> - 0.0		<i>u</i> - 0.0		<i>u</i> - 0.1		
Note: ">" designates a shared right or left turn lane.										
No recommendation.										

The 2029 analysis of the intersection of Alameda Blvd. / Driveway “C” demonstrates that the level-of-service will be acceptable for both the AM Peak Hour and PM Peak Hour NO BUILD and BUILD conditions analyzed in this report. Therefore, no recommendations are made for the intersection of Alameda Blvd. / Driveway “C”.

San Pedro Dr., Louisiana Blvd, & Alameda Blvd. are designated on the Futures 2040 Metropolitan Transportation Plan (2040 Long Range Bikeway System) as Proposed or Existing Bicycle Lanes. See Appendix page A-5 for a portion of the map.

Driveway “A” is located on Signal Ave., a major local roadway in the City of Albuquerque. Since Signal Ave. is not classified as a collector street or more, then no right turn or left turn deceleration lane is required.

Driveway “B” is a right-in, right-out driveway located on San Pedro Dr., a Major Collector Roadway with a posted speed limit of 35 MPH. The City of Albuquerque Development Process Manual stipulates that a classified roadway with a 35 MPH speed limit would warrant a right turn deceleration lane at a driveway if the right turn volume into the driveway was 40 vehicles per hour or more and a taper lane if the right turn volume into the driveway was 30 to 40 vehicles per hour. The projected northbound right turn volume into Driveway “B” will not exceed 23 vehicles per hour. Therefore, neither a northbound right turn deceleration lane nor a northbound right turn taper lane is warranted.

Driveways “C” and “D” are proposed right-in, right-out only driveways located on Alameda Blvd., a Regional Principal Arterial roadway with a posted speed limit of 35 MPH. The City of Albuquerque Development Process Manual stipulates that a classified roadway with a 35 MPH speed limit would warrant a right turn deceleration lane at a driveway if the right turn volume into the driveway was 40 vehicles per hour or more and a taper lane if the right turn volume into the driveway was 30 to 40 vehicles per hour. The projected northbound right turn volume into Driveway “B” will not exceed 24 vehicles per hour. Therefore, an eastbound right turn deceleration lane nor a eastbound right turn taper lane is warranted.

Summary of Deficiencies, Anticipated Impacts, and Recommendations

The existing 2019 analysis did not determine any significant deficiencies in the adjacent transportation system. The 2029 analysis yielded similar results. There was a minor issue for the northbound left turn queue at the intersection of Alameda Blvd. / San Pedro Dr. that should be addressed by this developer.

All of the other analyses in this Study demonstrated that the impact resulting from implementation of the proposed Alameda / San Pedro Development are not significant.

The following recommendations are made to mitigate the minor impact of the proposed Alameda / San Pedro Development on the adjacent transportation system:

Recommendations:

- 4) Site improvements for the project shall maintain adequate site distances for the four driveways on the project as well as for the existing signalized intersection of Alameda Blvd. / San Pedro Dr.
- 5) Alameda Blvd. / San Pedro Dr. – the northbound left turn lane on San Pedro Dr. at Alameda Blvd. should be extended to the maximum length possible by narrowing the existing bulb in the raised median located approximately 150 feet south of the northbound stop bar on San Pedro Dr. at Alameda Blvd. In narrowing the bulb, the raised median should be maintained so that the width is approximately 4 feet to match the existing raised median to the north. This measure should extend the existing left turn lane length by at least 75 feet.
- 6) Driveway Guidelines:
 - a. Driveway “A” – a full access unsignalized driveway designed and constructed with one entering lane and one exiting lane minimum.
 - b. Driveway “B” – a right-in, right-out only unsignalized driveway designed and constructed with one entering lane and one exiting lane minimum.
 - c. Driveway “C” and Driveway “D” - right-in, right-out only unsignalized driveway designed and constructed with one entering lane and one exiting lane minimum.
 - d. All driveways should be designed and constructed to accommodate delivery trucks for commercial uses.

Appendix

<u>SITE INFORMATION</u>	
Vicinity Map	A-1
Aerial Map	A-2
Conceptual Site Development Plan	A-3
2040 Long Range Roadway System Map (from MRMPO) – Portion	A-4
2040 Long Range Bikeway System Map (from MRMPO) – Portion	A-5
2017 Traffic Flow Map - Portion	A-6
<u>TRIP GENERATION</u>	
Trip Generation Summary Sheet	A-7
Trip Generation Data Sheets	A-8 thru 10
<u>TRIP DISTRIBUTION</u>	
DASZ Map	A-11
Trip Distribution Worksheets	A-12 thru A-13
Trip Distribution Map	A-14
Trip Assignments Map (% Entering)	A-15
Trip Assignments Map (% Exiting)	A-16
<u>HISTORIC GROWTH RATE</u>	
Historic Growth Table	A-17
Historic Growth Trendline Charts	A-18 thru A-24
<u>IMPLEMENTATION YEAR TURNING MOVEMENT COUNTS</u>	
Summary Table of Intersection Counts	A-25 thru A-27
Individual Intersection Turning Movement Counts Tables	A-28 thru A-47
<u>HORIZON YEAR TURNING MOVEMENT COUNTS</u>	
Summary Table of Intersection Counts	A-48 thru A-50
Individual Intersection Turning Movement Counts Tables	A-51 thru A-70
<u>IMPLEMENTATION YEAR (2019) INTERSECTION ANALYSES</u>	
Intersection #1 - Signalized Intersection Analyses (Alameda Blvd. / San Pedro Dr.)	A-71 thru A-102
Intersection #2 - Signalized Intersection Analyses (Alameda Blvd. / I-25 E. Ramp)	A-71 thru A-102
Intersection #3 - Signalized Intersection Analysis (Alameda Blvd. / I-25 W. Ramp)	A-71 thru A-102
Intersection #4 - Signalized Intersection Analysis (Alameda Blvd. / San Mateo Blvd.)	A-71 thru A-102
Intersection #5 - Signalized Intersection Analyses (Alameda Blvd. / Louisiana Blvd.)	A-71 thru A-102
Intersection #6 - Unsignalized Intersection Analyses (Signal Ave. / San Pedro Dr.)	A-71 thru A-102
Intersection #7 - Unsignalized Intersection Analyses (Signal Ave. / Driveway "A")	A-71 thru A-102
Intersection #8 - Unsignalized Intersection Analysis (Driveway "B" / San Pedro Rd.)	A-71 thru A-102
Intersection #9 - Unsignalized Intersection Analysis (Alameda Blvd. / Driveway "C")	A-71 thru A-102
Intersection #10 - Unsignalized Intersection Analyses (Alameda Blvd. / Driveway "D")	A-71 thru A-102
<u>HORIZON YEAR (2029) INTERSECTION ANALYSES</u>	
<u>Miscellaneous Data</u>	
Queuing Reports	A-135 thru A-154
ABQ Ride Route Map	A-155
Traffic Counts (Turning Movements Volumes)	A-156 thru A-167
City of Albuquerque Scoping Letter	A-168 thru A-17-

APPENDIX

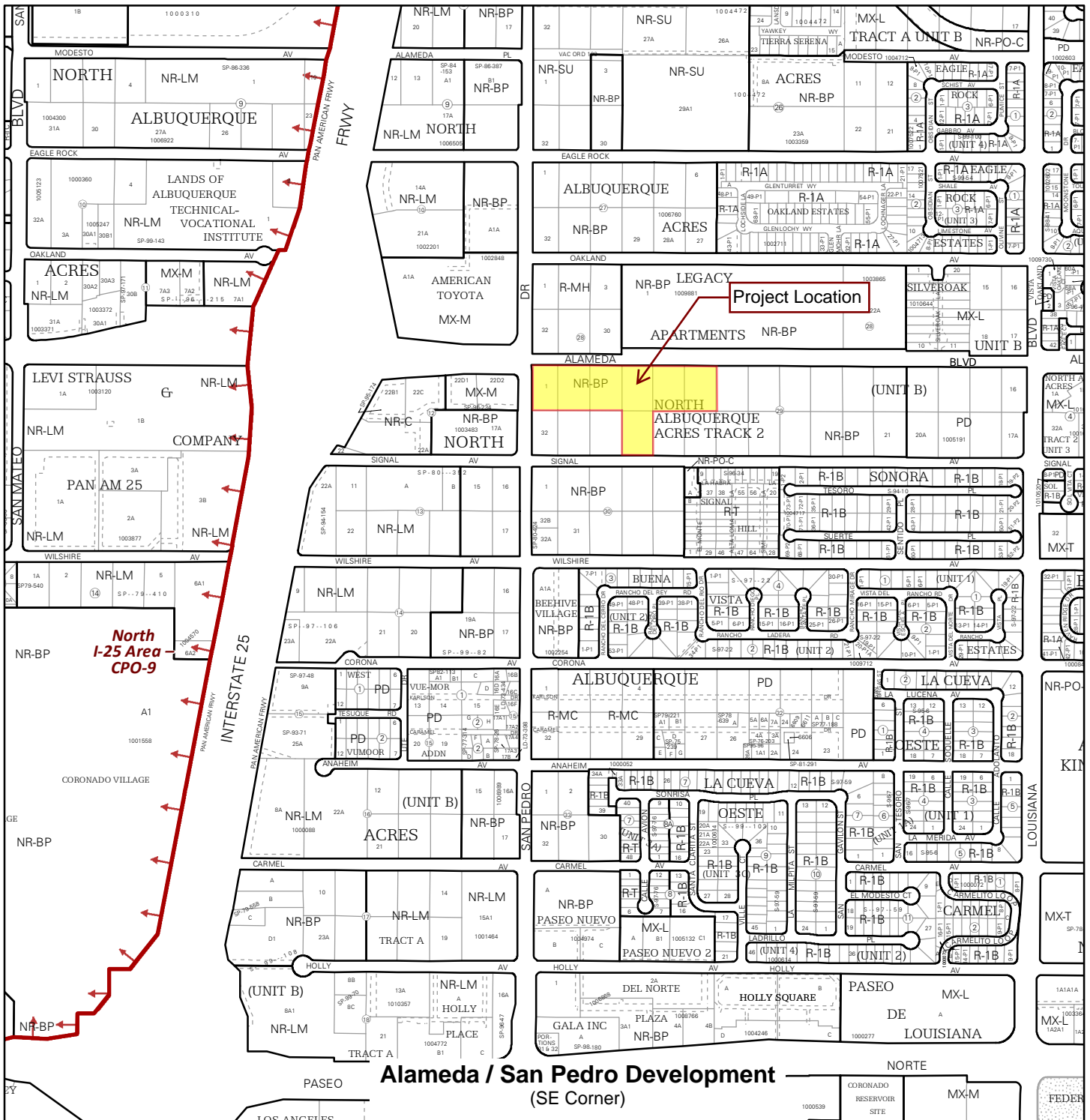

For more details about the Integrated Development Ordinance visit: <http://www.cabq.gov/planning/codes-policies-regulations/integrated-development-ordinance>

IDO Zone Atlas May 2018

IDO Zoning information as of May 17, 2018
The Zone Districts and Overlay Zones are established by the Integrated Development Ordinance (IDO).

Zone Atlas Page:
C-18-Z

- Easement
- Escarpment
- Petroglyph National Monument
- Areas Outside of City Limits
- Airport Protection Overlay (APO) Zone
- Character Protection Overlay (CPO) Zone
- Historic Protection Overlay (HPO) Zone
- View Protection Overlay (VPO) Zone

Gray Shading Represents Area Outside of the City Limits

N

0 250 500 1,000 Feet

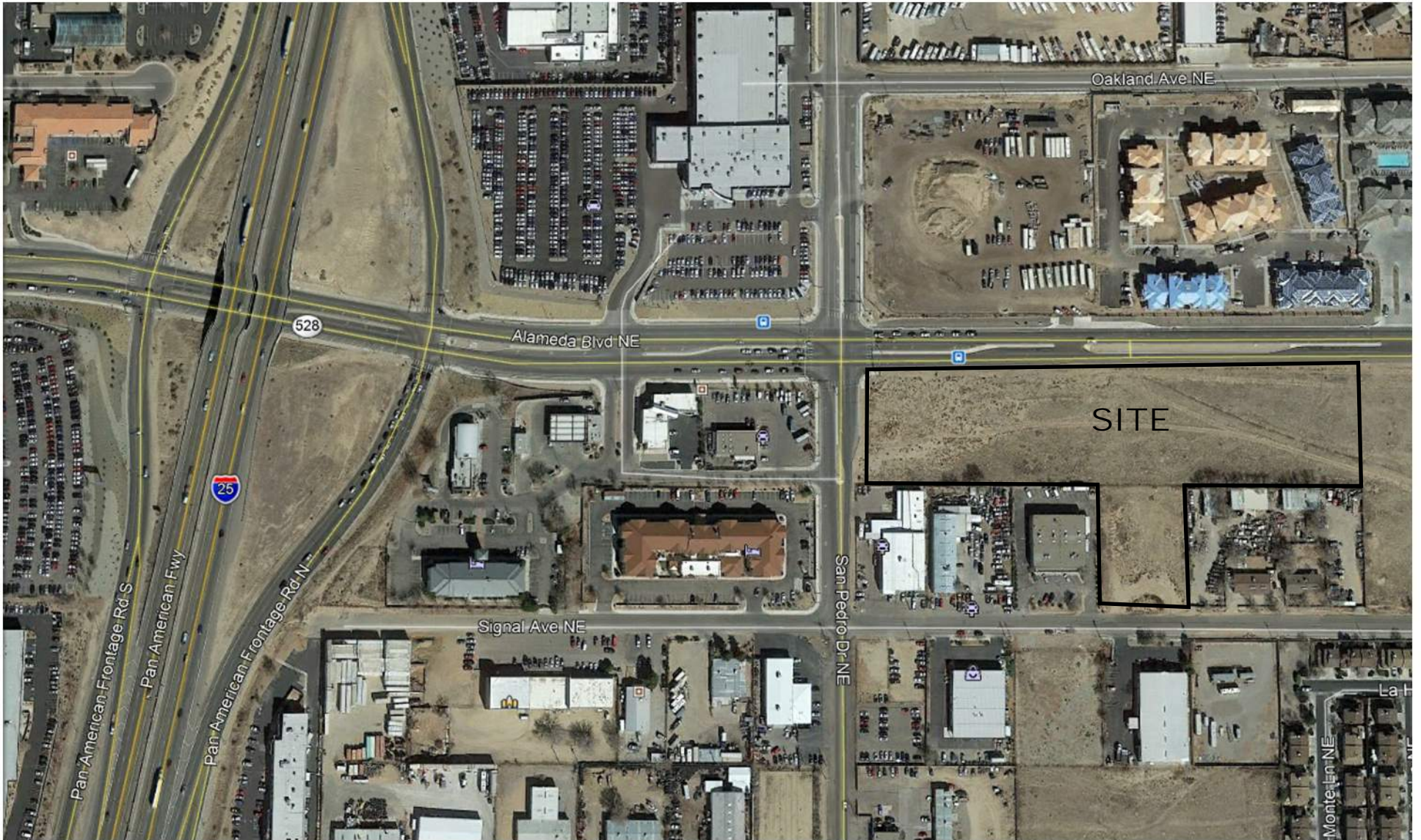

Alameda / San Pedro Development

(SE Corner)
Aerial Map

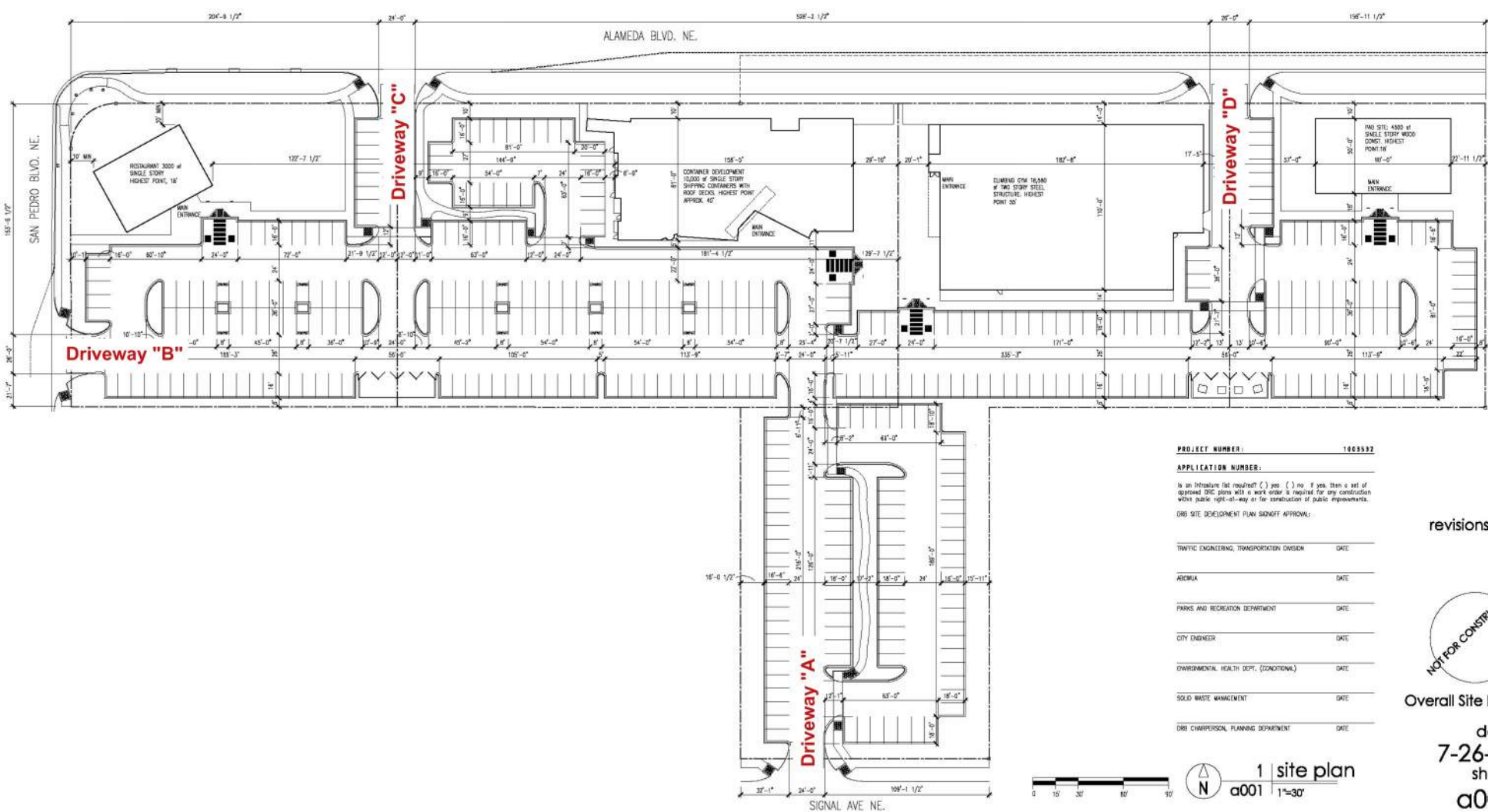

PROJECT NUMBER: 1805593

APPLICATION NUMBER:

Is an Infrastructure list required? () yes () no. If yes, then a set of approved DRP plans with a work order is required for any construction where public right-of-way or for construction of public improvements.

DRP SITE DEVELOPMENT PLAN SIGNOFF APPROVAL:

TRAFFIC ENGINEERING, TRANSPORTATION DIVISION DATE:

ARDMIA DATE:

PARKS AND RECREATION DEPARTMENT DATE:

CITY ENGINEER DATE:

ENVIRONMENTAL HEALTH DEPT. (CONDITIONAL) DATE:

SOLID WASTE MANAGEMENT DATE:

DRP CHAIRPERSON, PLANNING DEPARTMENT DATE:

revisions:



Overall Site Plan

date:
7-26-18
sheet:
a001



1 | site plan
a001 1"=30'



Appendix G – United States Census Bureau Data





QuickFacts

Albuquerque city, New Mexico

QuickFacts provides statistics for all states and counties, and for cities and towns with a **population of 5,000 or more**.

Table

All Topics	Albuquerque city, New Mexico
Population Estimates, July 1 2021, (V2021)	NA
PEOPLE	
Population	
Population Estimates, July 1 2021, (V2021)	NA
Population estimates base, April 1, 2020, (V2021)	NA
Population, percent change - April 1, 2020 (estimates base) to July 1, 2021, (V2021)	NA
Population, Census, April 1, 2020	564,559
Population, Census, April 1, 2010	545,852
Age and Sex	
Persons under 5 years, percent	5.9%
Persons under 18 years, percent	22.4%
Persons 65 years and over, percent	15.1%
Female persons, percent	51.3%
Race and Hispanic Origin	
White alone, percent	73.9%
Black or African American alone, percent (a)	3.3%
American Indian and Alaska Native alone, percent (a)	4.7%
Asian alone, percent (a)	2.9%
Native Hawaiian and Other Pacific Islander alone, percent (a)	0.1%
Two or More Races, percent	4.4%
Hispanic or Latino, percent (b)	49.2%
White alone, not Hispanic or Latino, percent	38.9%
Population Characteristics	
Veterans, 2015-2019	37,932
Foreign born persons, percent, 2015-2019	9.9%
Housing	
Housing units, July 1, 2019, (V2019)	X
Owner-occupied housing unit rate, 2015-2019	59.7%
Median value of owner-occupied housing units, 2015-2019	\$198,200
Median selected monthly owner costs -with a mortgage, 2015-2019	\$1,351
Median selected monthly owner costs -without a mortgage, 2015-2019	\$443
Median gross rent, 2015-2019	\$873
Building permits, 2020	X
Families & Living Arrangements	
Households, 2015-2019	224,166
Persons per household, 2015-2019	2.47
Living in same house 1 year ago, percent of persons age 1 year+, 2015-2019	84.0%
Language other than English spoken at home, percent of persons age 5 years+, 2015-2019	28.0%
Computer and Internet Use	
Households with a computer, percent, 2015-2019	90.7%
Households with a broadband Internet subscription, percent, 2015-2019	80.3%
Education	
High school graduate or higher, percent of persons age 25 years+, 2015-2019	89.7%
Bachelor's degree or higher, percent of persons age 25 years+, 2015-2019	35.2%
Health	
With a disability, under age 65 years, percent, 2015-2019	9.6%
Persons without health insurance, under age 65 years, percent	9.1%
Economy	
In civilian labor force, total, percent of population age 16 years+, 2015-2019	63.6%

In civilian labor force, female, percent of population age 16 years+, 2015-2019	59.6%
Total accommodation and food services sales, 2012 (\$1,000) (c)	1,578,983
Total health care and social assistance receipts/revenue, 2012 (\$1,000) (c)	5,183,979
Total manufacturers shipments, 2012 (\$1,000) (c)	D
Total retail sales, 2012 (\$1,000) (c)	9,067,367
Total retail sales per capita, 2012 (c)	\$16,325
Transportation	
Mean travel time to work (minutes), workers age 16 years+, 2015-2019	21.8
Income & Poverty	
Median household income (in 2019 dollars), 2015-2019	\$52,911
Per capita income in past 12 months (in 2019 dollars), 2015-2019	\$30,403
Persons in poverty, percent	△ 16.9%
 BUSINESSES	
Businesses	
Total employer establishments, 2019	X
Total employment, 2019	X
Total annual payroll, 2019 (\$1,000)	X
Total employment, percent change, 2018-2019	X
Total nonemployer establishments, 2018	X
All firms, 2012	42,272
Men-owned firms, 2012	20,208
Women-owned firms, 2012	16,129
Minority-owned firms, 2012	16,511
Nonminority-owned firms, 2012	23,116
Veteran-owned firms, 2012	4,147
Nonveteran-owned firms, 2012	35,096
 GEOGRAPHY	
Geography	
Population per square mile, 2010	2,907.6
Land area in square miles, 2010	187.73
FIPS Code	3502000

[About datasets used in this table](#)

Value Notes

 Estimates are not comparable to other geographic levels due to methodology differences that may exist between different data sources.

Some estimates presented here come from sample data, and thus have sampling errors that may render some apparent differences between geographies statistically indistinguishable. Click the Quick Info  icon to the row in TABLE view to learn about sampling error.

The vintage year (e.g., V2021) refers to the final year of the series (2020 thru 2021). Different vintage years of estimates are not comparable.

Fact Notes

- (a) Includes persons reporting only one race
- (c) Economic Census - Puerto Rico data are not comparable to U.S. Economic Census data
- (b) Hispanics may be of any race, so also are included in applicable race categories

Value Flags

- Either no or too few sample observations were available to compute an estimate, or a ratio of medians cannot be calculated because one or both of the median estimates falls in the lowest or upper in open ended distribution.
- F Fewer than 25 firms
- D Suppressed to avoid disclosure of confidential information
- N Data for this geographic area cannot be displayed because the number of sample cases is too small.
- FN Footnote on this item in place of data
- X Not applicable
- S Suppressed; does not meet publication standards
- NA Not available
- Z Value greater than zero but less than half unit of measure shown

QuickFacts data are derived from: Population Estimates, American Community Survey, Census of Population and Housing, Current Population Survey, Small Area Health Insurance Estimates, Small Area Income and Estimates, State and County Housing Unit Estimates, County Business Patterns, Nonemployer Statistics, Economic Census, Survey of Business Owners, Building Permits.

CONNECT WITH US      

[Accessibility](#) | [Information Quality](#) | [FOIA](#) | [Data Protection and Privacy Policy](#) | [U.S. Department of Commerce](#)



Appendix H – Year 2022 Build Capacity Analysis

1: San Pedro Drive & Alameda Boulevard

01/27/2022



Movement	EBL	EBT	EBR	WBL	WBT	WBR	NBL	NBT	NBR	SBL	SBT	SBR
Lane Configurations	↘	↑↑	↗	↘	↑↑		↘	↑↑		↘	↑↑	
Traffic Volume (veh/h)	73	494	243	53	716	19	217	51	33	3	26	124
Future Volume (veh/h)	73	494	243	53	716	19	217	51	33	3	26	124
Initial Q (Qb), veh	0	0	0	0	0	0	0	0	0	0	0	0
Ped-Bike Adj(A_pbT)	1.00		1.00	1.00		1.00	1.00		1.00	1.00		1.00
Parking Bus, Adj	1.00	1.00	1.00	1.00	1.00	1.00	1.00	1.00	1.00	1.00	1.00	1.00
Work Zone On Approach		No			No			No			No	
Adj Sat Flow, veh/h/ln	1870	1870	1870	1870	1870	1870	1870	1870	1870	1870	1870	1870
Adj Flow Rate, veh/h	79	537	264	58	778	21	236	55	36	3	28	135
Peak Hour Factor	0.92	0.92	0.92	0.92	0.92	0.92	0.92	0.92	0.92	0.92	0.92	0.92
Percent Heavy Veh, %	2	2	2	2	2	2	2	2	2	2	2	2
Cap, veh/h	522	1819	812	287	1316	36	354	516	309	232	197	175
Arrive On Green	0.18	0.51	0.51	0.04	0.37	0.37	0.13	0.24	0.24	0.00	0.11	0.11
Sat Flow, veh/h	1781	3554	1585	1781	3535	95	1781	2136	1280	1781	1777	1585
Grp Volume(v), veh/h	79	537	264	58	391	408	236	45	46	3	28	135
Grp Sat Flow(s),veh/h/ln	1781	1777	1585	1781	1777	1853	1781	1777	1640	1781	1777	1585
Q Serve(g_s), s	0.0	7.8	8.8	2.0	15.9	15.9	10.1	1.8	2.0	0.1	1.3	7.5
Cycle Q Clear(g_c), s	0.0	7.8	8.8	2.0	15.9	15.9	10.1	1.8	2.0	0.1	1.3	7.5
Prop In Lane	1.00		1.00	1.00		0.05	1.00		0.78	1.00		1.00
Lane Grp Cap(c), veh/h	522	1819	812	287	661	690	354	429	396	232	197	175
V/C Ratio(X)	0.15	0.30	0.33	0.20	0.59	0.59	0.67	0.10	0.12	0.01	0.14	0.77
Avail Cap(c_a), veh/h	522	1819	812	340	661	690	381	523	483	333	365	326
HCM Platoon Ratio	1.00	1.00	1.00	1.00	1.00	1.00	1.00	1.00	1.00	1.00	1.00	1.00
Upstream Filter(I)	1.00	1.00	1.00	1.00	1.00	1.00	1.00	1.00	1.00	1.00	1.00	1.00
Uniform Delay (d), s/veh	21.2	12.6	12.9	20.6	22.7	22.7	28.4	26.6	26.6	35.3	36.2	38.9
Incr Delay (d2), s/veh	0.1	0.4	1.1	0.3	3.9	3.7	4.0	0.1	0.1	0.0	0.3	6.9
Initial Q Delay(d3),s/veh	0.0	0.0	0.0	0.0	0.0	0.0	0.0	0.0	0.0	0.0	0.0	0.0
%ile BackOfQ(50%),veh/ln	1.2	3.0	3.1	0.8	7.0	7.3	4.5	0.7	0.8	0.1	0.6	3.2
Unsig. Movement Delay, s/veh												
LnGrp Delay(d),s/veh	21.3	13.0	13.9	20.9	26.6	26.4	32.4	26.7	26.8	35.4	36.5	45.8
LnGrp LOS	C	B	B	C	C	C	C	C	C	D	D	D
Approach Vol, veh/h		880			857			327			166	
Approach Delay, s/veh		14.0			26.1			30.8			44.1	
Approach LOS		B			C			C			D	
Timer - Assigned Phs	1	2	3	4	5	6	7	8				
Phs Duration (G+Y+Rc), s	8.3	50.6	16.6	14.5	20.9	38.0	4.9	26.2				
Change Period (Y+Rc), s	4.5	4.5	4.5	4.5	4.5	4.5	4.5	4.5				
Max Green Setting (Gmax), s	6.5	33.5	13.5	18.5	6.5	33.5	5.5	26.5				
Max Q Clear Time (g_c+I1), s	4.0	10.8	12.1	9.5	2.0	17.9	2.1	4.0				
Green Ext Time (p_c), s	0.0	4.5	0.1	0.5	0.1	4.4	0.0	0.4				
Intersection Summary												
HCM 6th Ctrl Delay			23.4									
HCM 6th LOS			C									

Intersection						
Int Delay, s/veh	0					
Movement	EBT	EBR	WBL	WBT	NBL	NBR
Lane Configurations	↑↑			↑↑		↑
Traffic Vol, veh/h	521	10	0	790	0	0
Future Vol, veh/h	521	10	0	790	0	0
Conflicting Peds, #/hr	0	0	0	0	0	0
Sign Control	Free	Free	Free	Free	Stop	Stop
RT Channelized	-	None	-	None	-	None
Storage Length	-	-	-	-	-	0
Veh in Median Storage, #	0	-	-	0	0	-
Grade, %	0	-	-	0	0	-
Peak Hour Factor	92	92	92	92	92	92
Heavy Vehicles, %	2	2	2	2	2	2
Mvmt Flow	566	11	0	859	0	0
Major/Minor	Major1	Major2	Minor1			
Conflicting Flow All	0	0	-	-	-	289
Stage 1	-	-	-	-	-	-
Stage 2	-	-	-	-	-	-
Critical Hdwy	-	-	-	-	-	6.94
Critical Hdwy Stg 1	-	-	-	-	-	-
Critical Hdwy Stg 2	-	-	-	-	-	-
Follow-up Hdwy	-	-	-	-	-	3.32
Pot Cap-1 Maneuver	-	-	0	-	0	*869
Stage 1	-	-	0	-	0	-
Stage 2	-	-	0	-	0	-
Platoon blocked, %	-	-	-	-	-	1
Mov Cap-1 Maneuver	-	-	-	-	-	*869
Mov Cap-2 Maneuver	-	-	-	-	-	-
Stage 1	-	-	-	-	-	-
Stage 2	-	-	-	-	-	-
Approach	EB	WB	NB			
HCM Control Delay, s	0	0	0			
HCM LOS				A		
Minor Lane/Major Mvmt	NBLn1	EBT	EBR	WBT		
Capacity (veh/h)	-	-	-	-		
HCM Lane V/C Ratio	-	-	-	-		
HCM Control Delay (s)	0	-	-	-		
HCM Lane LOS	A	-	-	-		
HCM 95th %tile Q(veh)	-	-	-	-		
Notes						
~: Volume exceeds capacity \$: Delay exceeds 300s +: Computation Not Defined *: All major volume in platoon						

3: Alameda Boulevard & Driveway B

01/27/2022

Intersection						
Int Delay, s/veh	0.3					
Movement	EBL	EBT	WBT	WBR	SBL	SBR
Lane Configurations						
Traffic Vol, veh/h	6	511	767	1	8	17
Future Vol, veh/h	6	511	767	1	8	17
Conflicting Peds, #/hr	0	0	0	0	0	0
Sign Control	Free	Free	Free	Free	Stop	Stop
RT Channelized	-	None	-	None	-	None
Storage Length	90	-	-	90	0	-
Veh in Median Storage, #	-	0	0	-	0	-
Grade, %	-	0	0	-	0	-
Peak Hour Factor	92	92	92	92	92	92
Heavy Vehicles, %	2	2	2	2	2	2
Mvmt Flow	7	555	834	1	9	18

Major/Minor	Major1	Major2	Minor2		
Conflicting Flow All	835	0	-	0	1126 417
Stage 1	-	-	-	-	834 -
Stage 2	-	-	-	-	292 -
Critical Hdwy	4.14	-	-	-	6.84 6.94
Critical Hdwy Stg 1	-	-	-	-	5.84 -
Critical Hdwy Stg 2	-	-	-	-	5.84 -
Follow-up Hdwy	2.22	-	-	-	3.52 3.32
Pot Cap-1 Maneuver	794	-	-	-	*288 585
Stage 1	-	-	-	-	*387 -
Stage 2	-	-	-	-	*853 -
Platoon blocked, %		-	-	-	1
Mov Cap-1 Maneuver	794	-	-	-	*285 585
Mov Cap-2 Maneuver	-	-	-	-	*285 -
Stage 1	-	-	-	-	*384 -
Stage 2	-	-	-	-	*853 -

Approach	EB	WB	SB
HCM Control Delay, s	0.1	0	13.8
HCM LOS			B

Minor Lane/Major Mvmt	EBL	EBT	WBT	WBR	SBLn1
Capacity (veh/h)	794	-	-	-	438
HCM Lane V/C Ratio	0.008	-	-	-	0.062
HCM Control Delay (s)	9.6	-	-	-	13.8
HCM Lane LOS	A	-	-	-	B
HCM 95th %tile Q(veh)	0	-	-	-	0.2

Notes
 ~: Volume exceeds capacity \$: Delay exceeds 300s +: Computation Not Defined *: All major volume in platoon

4: San Pedro Drive & Driveway C

01/27/2022

Intersection						
Int Delay, s/veh	0.1					
Movement	WBL	WBR	NBT	NBR	SBL	SBT
Lane Configurations		↗	↕			↕
Traffic Vol, veh/h	0	6	294	5	0	323
Future Vol, veh/h	0	6	294	5	0	323
Conflicting Peds, #/hr	0	0	0	0	0	0
Sign Control	Stop	Stop	Free	Free	Free	Free
RT Channelized	-	None	-	None	-	None
Storage Length	-	0	-	100	-	-
Veh in Median Storage, #	0	-	0	-	-	0
Grade, %	0	-	0	-	-	0
Peak Hour Factor	92	92	92	92	92	92
Heavy Vehicles, %	2	2	2	2	2	2
Mvmt Flow	0	7	320	5	0	351

Major/Minor	Minor1	Major1	Major2			
Conflicting Flow All	-	163	0	0	-	-
Stage 1	-	-	-	-	-	-
Stage 2	-	-	-	-	-	-
Critical Hdwy	-	6.94	-	-	-	-
Critical Hdwy Stg 1	-	-	-	-	-	-
Critical Hdwy Stg 2	-	-	-	-	-	-
Follow-up Hdwy	-	3.32	-	-	-	-
Pot Cap-1 Maneuver	0	853	-	-	0	-
Stage 1	0	-	-	-	0	-
Stage 2	0	-	-	-	0	-
Platoon blocked, %			-	-	-	-
Mov Cap-1 Maneuver	-	853	-	-	-	-
Mov Cap-2 Maneuver	-	-	-	-	-	-
Stage 1	-	-	-	-	-	-
Stage 2	-	-	-	-	-	-

Approach	WB	NB	SB
HCM Control Delay, s	9.3	0	0
HCM LOS	A		

Minor Lane/Major Mvmt	NBT	NBRWBLn1	SBT
Capacity (veh/h)	-	-	853
HCM Lane V/C Ratio	-	-	0.008
HCM Control Delay (s)	-	-	9.3
HCM Lane LOS	-	-	A
HCM 95th %tile Q(veh)	-	-	0

5: San Pedro Drive & Signal Avenue

01/27/2022

Intersection												
Int Delay, s/veh	1.2											
Movement	EBL	EBT	EBR	WBL	WBT	WBR	NBL	NBT	NBR	SBL	SBT	SBR
Lane Configurations		↕			↕			↕			↕	↕
Traffic Vol, veh/h	6	1	9	11	0	22	3	287	11	22	298	8
Future Vol, veh/h	6	1	9	11	0	22	3	287	11	22	298	8
Conflicting Peds, #/hr	0	0	0	0	0	0	0	0	0	0	0	0
Sign Control	Stop	Stop	Stop	Stop	Stop	Stop	Free	Free	Free	Free	Free	Free
RT Channelized	-	-	None	-	-	None	-	-	None	-	-	None
Storage Length	-	-	-	-	-	-	-	-	-	-	-	0
Veh in Median Storage, #	-	0	-	-	0	-	-	0	-	-	0	-
Grade, %	-	0	-	-	0	-	-	0	-	-	0	-
Peak Hour Factor	92	92	92	92	92	92	92	92	92	92	92	92
Heavy Vehicles, %	2	2	2	2	2	2	2	2	2	2	2	2
Mvmt Flow	7	1	10	12	0	24	3	312	12	24	324	9

Major/Minor	Minor2		Minor1		Major1		Major2					
Conflicting Flow All	708	702	324	706	705	318	333	0	0	324	0	0
Stage 1	372	372	-	324	324	-	-	-	-	-	-	-
Stage 2	336	330	-	382	381	-	-	-	-	-	-	-
Critical Hdwy	7.12	6.52	6.22	7.12	6.52	6.22	4.12	-	-	4.12	-	-
Critical Hdwy Stg 1	6.12	5.52	-	6.12	5.52	-	-	-	-	-	-	-
Critical Hdwy Stg 2	6.12	5.52	-	6.12	5.52	-	-	-	-	-	-	-
Follow-up Hdwy	3.518	4.018	3.318	3.518	4.018	3.318	2.218	-	-	2.218	-	-
Pot Cap-1 Maneuver	379	376	833	380	375	723	1254	-	-	1236	-	-
Stage 1	732	656	-	688	650	-	-	-	-	-	-	-
Stage 2	678	646	-	721	649	-	-	-	-	-	-	-
Platoon blocked, %	1	1	1	1	1	1	-	-	-	-	-	-
Mov Cap-1 Maneuver	359	366	833	367	365	723	1254	-	-	1236	-	-
Mov Cap-2 Maneuver	359	366	-	367	365	-	-	-	-	-	-	-
Stage 1	730	640	-	686	648	-	-	-	-	-	-	-
Stage 2	654	644	-	694	633	-	-	-	-	-	-	-

Approach	EB		WB		NB		SB	
HCM Control Delay, s	12		12.1		0.1		0.5	
HCM LOS	B		B					

Minor Lane/Major Mvmt	NBL	NBT	NBR	EBLn1WBLn1	SBL	SBT	SBR
Capacity (veh/h)	1254	-	-	529	546	1236	-
HCM Lane V/C Ratio	0.003	-	-	0.033	0.066	0.019	-
HCM Control Delay (s)	7.9	0	-	12	12.1	8	0
HCM Lane LOS	A	A	-	B	B	A	A
HCM 95th %tile Q(veh)	0	-	-	0.1	0.2	0.1	-

1: San Pedro Drive & Alameda Boulevard

01/27/2022



Movement	EBL	EBT	EBR	WBL	WBT	WBR	NBL	NBT	NBR	SBL	SBT	SBR
Lane Configurations	↖	↗	↘	↖	↗		↖	↗		↖	↗	
Traffic Volume (veh/h)	91	815	382	37	495	10	272	38	69	26	73	150
Future Volume (veh/h)	91	815	382	37	495	10	272	38	69	26	73	150
Initial Q (Qb), veh	0	0	0	0	0	0	0	0	0	0	0	0
Ped-Bike Adj(A_pbT)	1.00		1.00	1.00		1.00	1.00		1.00	1.00		1.00
Parking Bus, Adj	1.00	1.00	1.00	1.00	1.00	1.00	1.00	1.00	1.00	1.00	1.00	1.00
Work Zone On Approach		No			No			No			No	
Adj Sat Flow, veh/h/ln	1870	1870	1870	1870	1870	1870	1870	1870	1870	1870	1870	1870
Adj Flow Rate, veh/h	99	886	415	40	538	11	296	41	75	28	79	163
Peak Hour Factor	0.92	0.92	0.92	0.92	0.92	0.92	0.92	0.92	0.92	0.92	0.92	0.92
Percent Heavy Veh, %	2	2	2	2	2	2	2	2	2	2	2	2
Cap, veh/h	547	1722	768	192	1326	27	382	448	400	296	232	207
Arrive On Green	0.15	0.48	0.48	0.04	0.37	0.37	0.15	0.25	0.25	0.03	0.13	0.13
Sat Flow, veh/h	1781	3554	1585	1781	3561	73	1781	1777	1585	1781	1777	1585
Grp Volume(v), veh/h	99	886	415	40	268	281	296	41	75	28	79	163
Grp Sat Flow(s),veh/h/ln	1781	1777	1585	1781	1777	1857	1781	1777	1585	1781	1777	1585
Q Serve(g_s), s	0.0	15.4	16.5	1.4	10.0	10.1	12.5	1.6	3.3	1.2	3.6	9.0
Cycle Q Clear(g_c), s	0.0	15.4	16.5	1.4	10.0	10.1	12.5	1.6	3.3	1.2	3.6	9.0
Prop In Lane	1.00		1.00	1.00		0.04	1.00		1.00	1.00		1.00
Lane Grp Cap(c), veh/h	547	1722	768	192	661	691	382	448	400	296	232	207
V/C Ratio(X)	0.18	0.51	0.54	0.21	0.41	0.41	0.77	0.09	0.19	0.09	0.34	0.79
Avail Cap(c_a), veh/h	547	1722	768	258	661	691	382	523	467	355	365	326
HCM Platoon Ratio	1.00	1.00	1.00	1.00	1.00	1.00	1.00	1.00	1.00	1.00	1.00	1.00
Upstream Filter(I)	1.00	1.00	1.00	1.00	1.00	1.00	1.00	1.00	1.00	1.00	1.00	1.00
Uniform Delay (d), s/veh	19.2	15.9	16.2	21.6	20.9	20.9	27.1	25.7	26.4	32.4	35.6	37.9
Incr Delay (d2), s/veh	0.2	1.1	2.7	0.5	1.8	1.8	9.6	0.1	0.2	0.1	0.9	6.6
Initial Q Delay(d3),s/veh	0.0	0.0	0.0	0.0	0.0	0.0	0.0	0.0	0.0	0.0	0.0	0.0
%ile BackOfQ(50%),veh/ln	1.4	6.0	6.1	0.6	4.3	4.5	6.1	0.7	1.2	0.5	1.6	3.8
Unsig. Movement Delay, s/veh												
LnGrp Delay(d),s/veh	19.4	17.0	18.9	22.2	22.7	22.7	36.7	25.8	26.6	32.5	36.5	44.5
LnGrp LOS	B	B	B	C	C	C	D	C	C	C	D	D
Approach Vol, veh/h		1400			589			412			270	
Approach Delay, s/veh		17.8			22.7			33.8			40.9	
Approach LOS		B			C			C			D	
Timer - Assigned Phs	1	2	3	4	5	6	7	8				
Phs Duration (G+Y+Rc), s	7.7	48.1	18.0	16.2	17.8	38.0	7.0	27.2				
Change Period (Y+Rc), s	4.5	4.5	4.5	4.5	4.5	4.5	4.5	4.5				
Max Green Setting (Gmax), s	6.5	33.5	13.5	18.5	6.5	33.5	5.5	26.5				
Max Q Clear Time (g_c+I1), s	3.4	18.5	14.5	11.0	2.0	12.1	3.2	5.3				
Green Ext Time (p_c), s	0.0	6.7	0.0	0.8	0.1	3.1	0.0	0.5				
Intersection Summary												
HCM 6th Ctrl Delay				23.7								
HCM 6th LOS				C								

Intersection						
Int Delay, s/veh	0.2					
Movement	EBT	EBR	WBL	WBT	NBL	NBR
Lane Configurations	↑↑			↑↑		↑
Traffic Vol, veh/h	825	80	0	547	0	35
Future Vol, veh/h	825	80	0	547	0	35
Conflicting Peds, #/hr	0	0	0	0	0	0
Sign Control	Free	Free	Free	Free	Stop	Stop
RT Channelized	-	None	-	None	-	None
Storage Length	-	-	-	-	-	0
Veh in Median Storage, #	0	-	-	0	0	-
Grade, %	0	-	-	0	0	-
Peak Hour Factor	92	92	92	92	92	92
Heavy Vehicles, %	2	2	2	2	2	2
Mvmt Flow	897	87	0	595	0	38

Major/Minor	Major1	Major2	Minor1		
Conflicting Flow All	0	0	-	-	492
Stage 1	-	-	-	-	-
Stage 2	-	-	-	-	-
Critical Hdwy	-	-	-	-	6.94
Critical Hdwy Stg 1	-	-	-	-	-
Critical Hdwy Stg 2	-	-	-	-	-
Follow-up Hdwy	-	-	-	-	3.32
Pot Cap-1 Maneuver	-	-	0	-	*767
Stage 1	-	-	0	-	-
Stage 2	-	-	0	-	-
Platoon blocked, %	-	-	-	-	1
Mov Cap-1 Maneuver	-	-	-	-	*767
Mov Cap-2 Maneuver	-	-	-	-	-
Stage 1	-	-	-	-	-
Stage 2	-	-	-	-	-

Approach	EB	WB	NB
HCM Control Delay, s	0	0	9.9
HCM LOS			A

Minor Lane/Major Mvmt	NBLn1	EBT	EBR	WBT
Capacity (veh/h)	767	-	-	-
HCM Lane V/C Ratio	0.05	-	-	-
HCM Control Delay (s)	9.9	-	-	-
HCM Lane LOS	A	-	-	-
HCM 95th %tile Q(veh)	0.2	-	-	-

Notes
 ~: Volume exceeds capacity \$: Delay exceeds 300s +: Computation Not Defined *: All major volume in platoon

3: Alameda Boulevard & Driveway B

01/27/2022

Intersection						
Int Delay, s/veh	0.2					
Movement	EBL	EBT	WBT	WBR	SBL	SBR
Lane Configurations	↘	↑↑	↑↑	↗	↘	
Traffic Vol, veh/h	21	841	539	3	3	8
Future Vol, veh/h	21	841	539	3	3	8
Conflicting Peds, #/hr	0	0	0	0	0	0
Sign Control	Free	Free	Free	Free	Stop	Stop
RT Channelized	-	None	-	None	-	None
Storage Length	90	-	-	90	0	-
Veh in Median Storage, #	-	0	0	-	0	-
Grade, %	-	0	0	-	0	-
Peak Hour Factor	92	92	92	92	92	92
Heavy Vehicles, %	2	2	2	2	2	2
Mvmt Flow	23	914	586	3	3	9

Major/Minor	Major1	Major2	Minor2		
Conflicting Flow All	589	0	-	0	1089 293
Stage 1	-	-	-	-	586 -
Stage 2	-	-	-	-	503 -
Critical Hdwy	4.14	-	-	-	6.84 6.94
Critical Hdwy Stg 1	-	-	-	-	5.84 -
Critical Hdwy Stg 2	-	-	-	-	5.84 -
Follow-up Hdwy	2.22	-	-	-	3.52 3.32
Pot Cap-1 Maneuver	982	-	-	-	*540 703
Stage 1	-	-	-	-	*519 -
Stage 2	-	-	-	-	*691 -
Platoon blocked, %		-	-	-	1
Mov Cap-1 Maneuver	982	-	-	-	*527 703
Mov Cap-2 Maneuver	-	-	-	-	*527 -
Stage 1	-	-	-	-	*507 -
Stage 2	-	-	-	-	*691 -

Approach	EB	WB	SB
HCM Control Delay, s	0.2	0	10.7
HCM LOS			B

Minor Lane/Major Mvmt	EBL	EBT	WBT	WBR	SBLn1
Capacity (veh/h)	982	-	-	-	644
HCM Lane V/C Ratio	0.023	-	-	-	0.019
HCM Control Delay (s)	8.8	-	-	-	10.7
HCM Lane LOS	A	-	-	-	B
HCM 95th %tile Q(veh)	0.1	-	-	-	0.1

Notes
 ~: Volume exceeds capacity \$: Delay exceeds 300s +: Computation Not Defined *: All major volume in platoon

4: San Pedro Drive & Driveway C

01/27/2022

Intersection						
Int Delay, s/veh	0.6					
Movement	WBL	WBR	NBT	NBR	SBL	SBT
Lane Configurations		↗	↕			↕
Traffic Vol, veh/h	3	48	327	42	0	486
Future Vol, veh/h	3	48	327	42	0	486
Conflicting Peds, #/hr	0	0	0	0	0	0
Sign Control	Stop	Stop	Free	Free	Free	Free
RT Channelized	-	None	-	None	-	None
Storage Length	-	0	-	100	-	-
Veh in Median Storage, #	0	-	0	-	-	0
Grade, %	0	-	0	-	-	0
Peak Hour Factor	92	92	92	92	92	92
Heavy Vehicles, %	2	2	2	2	2	2
Mvmt Flow	3	52	355	46	0	528

Major/Minor	Minor1	Major1	Major2			
Conflicting Flow All	642	201	0	0	-	-
Stage 1	378	-	-	-	-	-
Stage 2	264	-	-	-	-	-
Critical Hdwy	6.84	6.94	-	-	-	-
Critical Hdwy Stg 1	5.84	-	-	-	-	-
Critical Hdwy Stg 2	5.84	-	-	-	-	-
Follow-up Hdwy	3.52	3.32	-	-	-	-
Pot Cap-1 Maneuver	*667	806	-	-	0	-
Stage 1	*663	-	-	-	0	-
Stage 2	*853	-	-	-	0	-
Platoon blocked, %	1	-	-	-	-	-
Mov Cap-1 Maneuver	*667	806	-	-	-	-
Mov Cap-2 Maneuver	*667	-	-	-	-	-
Stage 1	*663	-	-	-	-	-
Stage 2	*853	-	-	-	-	-

Approach	WB	NB	SB
HCM Control Delay, s	9.8	0	0
HCM LOS	A		

Minor Lane/Major Mvmt	NBT	NBRWBLn1	SBT
Capacity (veh/h)	-	-	806
HCM Lane V/C Ratio	-	-	0.065
HCM Control Delay (s)	-	-	9.8
HCM Lane LOS	-	-	A
HCM 95th %tile Q(veh)	-	-	0.2

Notes
 ~: Volume exceeds capacity \$: Delay exceeds 300s +: Computation Not Defined *: All major volume in platoon

5: San Pedro Drive & Signal Avenue

01/27/2022

Intersection												
Int Delay, s/veh	2.3											
Movement	EBL	EBT	EBR	WBL	WBT	WBR	NBL	NBT	NBR	SBL	SBT	SBR
Lane Configurations		↕			↕			↕			↕	↕
Traffic Vol, veh/h	14	4	11	20	3	31	25	332	19	48	441	31
Future Vol, veh/h	14	4	11	20	3	31	25	332	19	48	441	31
Conflicting Peds, #/hr	0	0	0	0	0	0	0	0	0	0	0	0
Sign Control	Stop	Stop	Stop	Stop	Stop	Stop	Free	Free	Free	Free	Free	Free
RT Channelized	-	-	None	-	-	None	-	-	None	-	-	None
Storage Length	-	-	-	-	-	-	-	-	-	-	-	0
Veh in Median Storage, #	-	0	-	-	0	-	-	0	-	-	0	-
Grade, %	-	0	-	-	0	-	-	0	-	-	0	-
Peak Hour Factor	92	92	92	92	92	92	92	92	92	92	92	92
Heavy Vehicles, %	2	2	2	2	2	2	2	2	2	2	2	2
Mvmt Flow	15	4	12	22	3	34	27	361	21	52	479	34

Major/Minor	Minor2		Minor1		Major1		Major2					
Conflicting Flow All	1027	1019	479	1034	1043	372	513	0	0	382	0	0
Stage 1	583	583	-	426	426	-	-	-	-	-	-	-
Stage 2	444	436	-	608	617	-	-	-	-	-	-	-
Critical Hdwy	7.12	6.52	6.22	7.12	6.52	6.22	4.12	-	-	4.12	-	-
Critical Hdwy Stg 1	6.12	5.52	-	6.12	5.52	-	-	-	-	-	-	-
Critical Hdwy Stg 2	6.12	5.52	-	6.12	5.52	-	-	-	-	-	-	-
Follow-up Hdwy	3.518	4.018	3.318	3.518	4.018	3.318	2.218	-	-	2.218	-	-
Pot Cap-1 Maneuver	205	218	*733	202	208	674	1061	-	-	1176	-	-
Stage 1	580	526	-	606	586	-	-	-	-	-	-	-
Stage 2	593	580	-	555	501	-	-	-	-	-	-	-
Platoon blocked, %	1	1	1	1	1	1	-	-	-	-	-	-
Mov Cap-1 Maneuver	179	198	*733	181	189	674	1061	-	-	1176	-	-
Mov Cap-2 Maneuver	179	198	-	181	189	-	-	-	-	-	-	-
Stage 1	562	494	-	587	567	-	-	-	-	-	-	-
Stage 2	542	561	-	508	470	-	-	-	-	-	-	-

Approach	EB		WB		NB		SB	
HCM Control Delay, s	21		19.1		0.6		0.8	
HCM LOS	C		C					

Minor Lane/Major Mvmt	NBL	NBT	NBR	EBLn1WBLn1	SBL	SBT	SBR
Capacity (veh/h)	1061	-	-	256	313	1176	-
HCM Lane V/C Ratio	0.026	-	-	0.123	0.188	0.044	-
HCM Control Delay (s)	8.5	0	-	21	19.1	8.2	0
HCM Lane LOS	A	A	-	C	C	A	A
HCM 95th %tile Q(veh)	0.1	-	-	0.4	0.7	0.1	-

Notes
 ~: Volume exceeds capacity \$: Delay exceeds 300s +: Computation Not Defined *: All major volume in platoon