

GENERAL SHEET NOTES

- A. SITE DIMENSIONS COMPLY WITH CITY OF ALBUQUERQUE INTEGRATED DEVELOPMENT ORDINANCE (IDO) SECTION 14-16-5. DEVELOPMENT STANDARDS SHALL INCLUDE 5-2 (G) LANDFILL BUFFERS IF/WHEN STRUCTURES ARE LOCATED WITHIN LANDFILL BUFFERS.
- B. SITE PLAN SHALL COMPLY WITH ADA STANDARDS & GUIDELINES AND BUILT ACCORDING TO THE CITY OF ALBUQUERQUE STANDARDS.
- C. PARKING LOTS SHALL INTEGRATE LOW-IMPACT DESIGN TO MITIGATE STORMWATER DISCHARGE VOLUMES AND SUPPLEMENT IRRIGATION DEMAND.
- D. STREETS, PARKING SPACES AND ASSOCIATED DRIVES TO BE ASPHALT UNLESS NOTED OTHERWISE. PERVIOUS PAVING, BASE COURSE, OR OTHER PERVIOUS PAVING MATERIALS ARE ENCOURAGED AND PREFERRED.
- E. EXISTING METHANE MONITORING WELLS WILL BE MAPPED AND PROPERLY HANDLED DURING THE DESIGN PHASE, INCLUDING POTENTIAL PLUGGING AND ABANDONMENT.
- F. THE OWNER SHALL CONDUCT A GEOTECHNICAL INVESTIGATION PRIOR TO THE DESIGN PHASES WHICH WILL INCLUDE THE TESTING OF SOILS FOR TRACE METALS ASSOCIATED WITH PAST SLUDGE DRYING AREAS AND THE CLEARANCE OF LAND USES THROUGH NMED.
- G. LIMITS OF EXISTING LANDFILL SHALL BE IDENTIFIED PRIOR TO DESIGN. FINAL ALIGNMENTS OF ROADS MAY BE MODIFIED TO ADDRESS LANDFILL LIMITS.
- H. TRANSIT STOPS SHALL BE COORDINATED BY PHASE TO ADHERE TO CABO TRANSIT MASTER PLANNING AND SERVICE EXPANSION AS NECESSARY.
- I. **THIS MASTER PLAN IS CONCEPTUAL. AN APPROVED TRAFFIC CIRCULATION LAYOUT (TCL) SHALL BE REQUIRED PRIOR TO BUILDING PERMIT.**

PARKING COUNT

- A. REQUIRED PARKING SPACES AND STANDARD DRIVE DIMENSIONS SHALL BE IN ACCORDANCE WITH IDO STANDARDS AND TO BE DETERMINED AS DEVELOPMENT OCCURS.
- B. PARKING TO BE SHARED WITH EXISTING ISLETA AMPHITHEATER.

SHEET KEYED NOTES

- 1. MULTI-USE TURF GRASS ATHLETIC FIELD
- 2. EXISTING TURF GRASS ATHLETIC FIELD
- 3. TURF GRASS USL PRACTICE FIELD
- 4. EXISTING PARKING, 4,154 SPACES
- 5. PARKING
- 6. RV PARKING
- 7. UNDEVELOPABLE AREA (FORMER LANDFILL)
- 8. PARK
- 9. STORMWATER RETENTION AREA
- 10. MAINTENANCE YARD
- 11. SPORT FIELD LIGHTING
- 12. REST AREA WITH SHADE AND RESTROOMS
- 13. SPORT LIFESTYLE CENTER
- 14. INDOOR SYNTHETIC TURF PRACTICE FACILITY
- 15. VEHICULAR ROADWAY
- 16. PEDESTRIAN WALK
- 17. EXISTING ISLETA AMPHITHEATER
- 18. PROPERTY LINE
- 19. EXISTING WELL WATER TANK
- 20. SYNTHETIC TURF MULTI-USE FIELD
- 21. EXISTING NON-POTABLE WELL
- 22. REMOTE CONTROL CAR PARK
- 23. TRASH ENCLOSURE; SEE A2/AS402
- 24. EXISTING EASEMENT
- 25. TRANSIT STOP
- 26. 100' LANDFILL BUFFER
- 27. EXISTING ROAD TO REMAIN
- 28. PROPOSED DESIGN TIES INTO EXISTING IMPROVEMENTS

SITE INFORMATION

	RECREATION AMENITIES	PARKING REQUIRED	PARKING PROVIDED
SPORTS LIFESTYLE CENTER	86,600 SF	2 SPACES / 1000 SF = 174 SPACES	752 (PHASES III & IV)
INDOOR PRACTICE FACILITY	112,134 SF	2 SPACES / 1000 SF = 225 SPACES	4,154 (SHARED) + 178 (PHASE I)
MAINT. FACILITY	3,000 SF	N/A	10
CLUBHOUSE	13,000 SF	2 SPACES / 1000 SF = 26 SPACES	4,154 (SHARED) + 24 = 4,178
OUTDOOR PRACTICE FACILITY	120,000 SF	4 SPACES/ 1,000 SF = 480 SPACES	4,154 (SHARED) + 154 = 4,308
SPORTS FIELDS *	3,565,621 SF (30 FIELDS)	50 SPACES/ FIELD = 1,500 SPACES	4,154 (SHARED) + 3970 (ALL PHASES)
TOTAL PARKING			8139

* PARKING REQUIREMENT APPROVED BY BERNALILLO COUNTY PARKS & RECREATION

LEGAL DESCRIPTION

- A. THAT CERTAIN PARCEL SITUATE WITHIN SECTION 21, AND THE EAST HALF OF SECTION 20, TOWNSHIP 9 NORTH, RANGE 3 EAST, BERNALILLO COUNTY, NEW MEXICO CONSISTING OF 643 ACRES ±.

**DEKKER
PERICH
SABATINI**

ARCHITECTURE
DESIGN
INSPIRATION

ARCHITECT

ENGINEER

PROJECT

**BERNALILLO COUNTY REGIONAL
OUTDOOR SPORTS COMPLEX**
5601 UNIVERSITY BLVD SE
ALBUQUERQUE, NM 87106

REVISIONS

- △
- △
- △
- △

DRAWN BY BG

REVIEWED BY KR

DATE 10/30/19

PROJECT NO. 17-0090.001

DRAWING NAME

SITE PLAN

SHEET NO.

AS101

OF

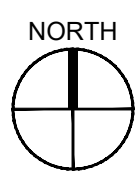

A1

SITE PLAN

1" = 200'-0"

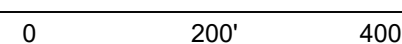

PARKING COUNT

PHASE	TOTAL PARKING SPACES PROVIDED	ADA SPACES PROVIDED	ADA VAN SPACES PROVIDED	MOTORCYCLE SPACES PROVIDED	BICYCLE PARKING PROVIDED
I	178	8	2	5	18
II	951	20	4	8	96
III & IV	2841	39	7	12	285
TOTAL:	3970	67	13	25	399
PROPOSED RV PARKING	15	0	0	0	0
EXISTING PARKING SPACES	4154	54	0	0	0
GRAND TOTAL:	8139	121	13	25	399

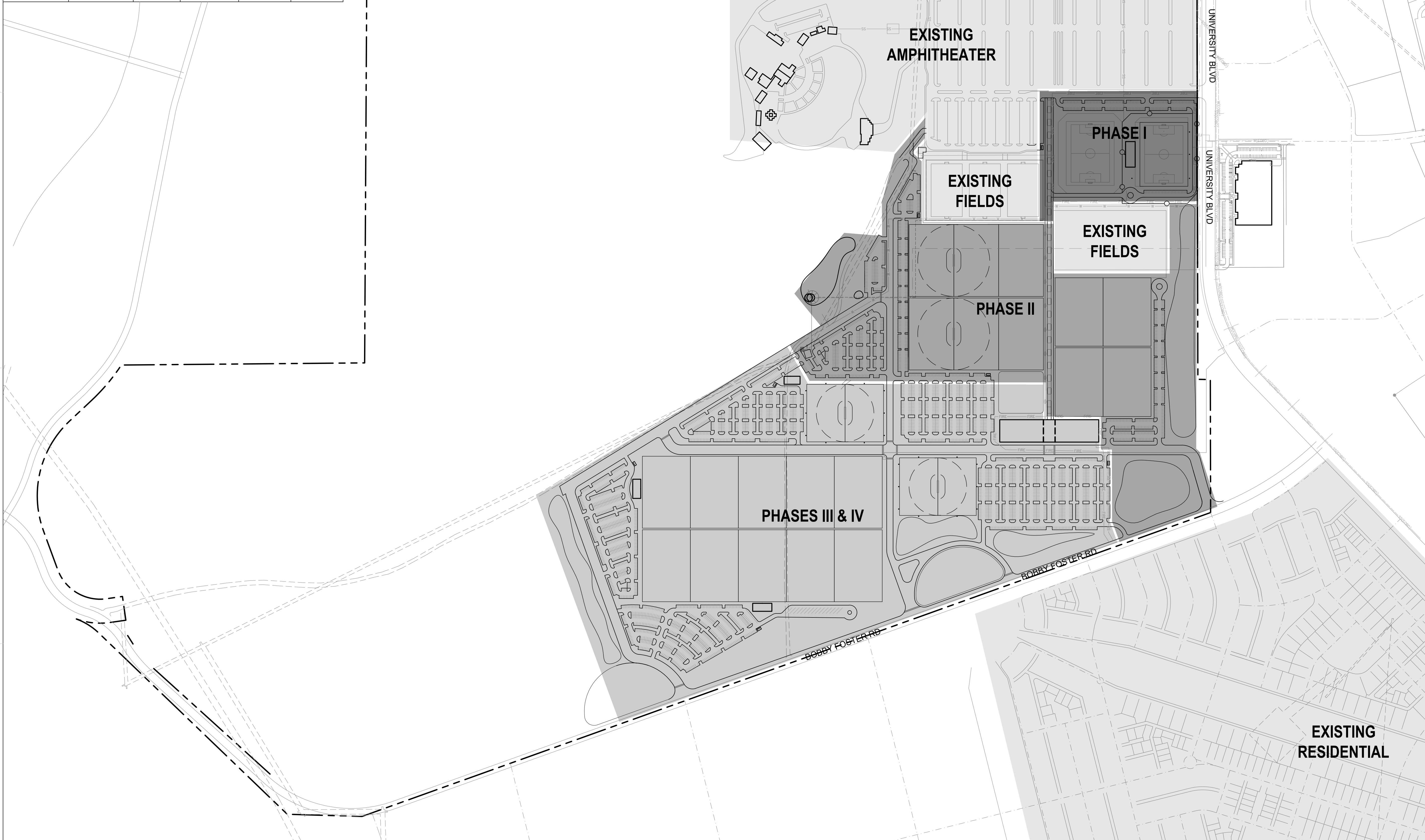

**DEKKER
PERICH
SABATINI**

ARCHITECTURE
DESIGN
INSPIRATION

ARCHITECT

ENGINEER

PROJECT

**BERNALILLO COUNTY REGIONAL
OUTDOOR SPORTS COMPLEX**
5601 UNIVERSITY BLVD SE
ALBUQUERQUE, NM 87106

REVISIONS
△
△
△
△

DRAWN BY: BG
REVIEWED BY: KR
DATE: 10/30/19
PROJECT NO.: 17-0090.001
DRAWING NAME:

PHASING PLAN

SHEET NO.
AS102
OF

NORTH
A1 **PHASING PLAN**
1" = 300'-0"
0 300' 600'

SHEET KEYED NOTES

1. CONCRETE PEDESTRIAN WALK
2. CONCRETE ENTRY PLAZA
3. SPECTATOR BLEACHER SEATING SYSTEM
4. BLEACHER EXPANSION AREA
5. EXISTING PARKING
6. EXISTING TURF GRASS MULTI-USE FIELDS
7. FUTURE INDOOR PRACTICE FACILITY
8. SERVICE AREA
9. TURF GRASS PRACTICE FIELD
10. NEW MEXICO UNITED CLUBHOUSE
11. PROPOSED PARKING
12. SPORT FIELD LIGHTING
13. PROPERTY LINE
14. EXISTING VEHICLE ENTRY ROAD
15. EMERGENCY AND SERVICE ACCESS ROAD
16. VEHICULAR GATE
17. ORNAMENTAL IRON FENCING, COLOR BLACK
18. RIGHT IN, RIGHT OUT INTERSECTION
19. TRASH ENCLOSURE; SEE A2/AS402

**DEKKER
PERICH
SABATINI**

ARCHITECTURE
DESIGN
INSPIRATION

ARCHITECT

ENGINEER

PROJECT

**BERNALILLO COUNTY REGIONAL
OUTDOOR SPORTS COMPLEX**
5601 UNIVERSITY BLVD SE
ALBUQUERQUE, NM 87106

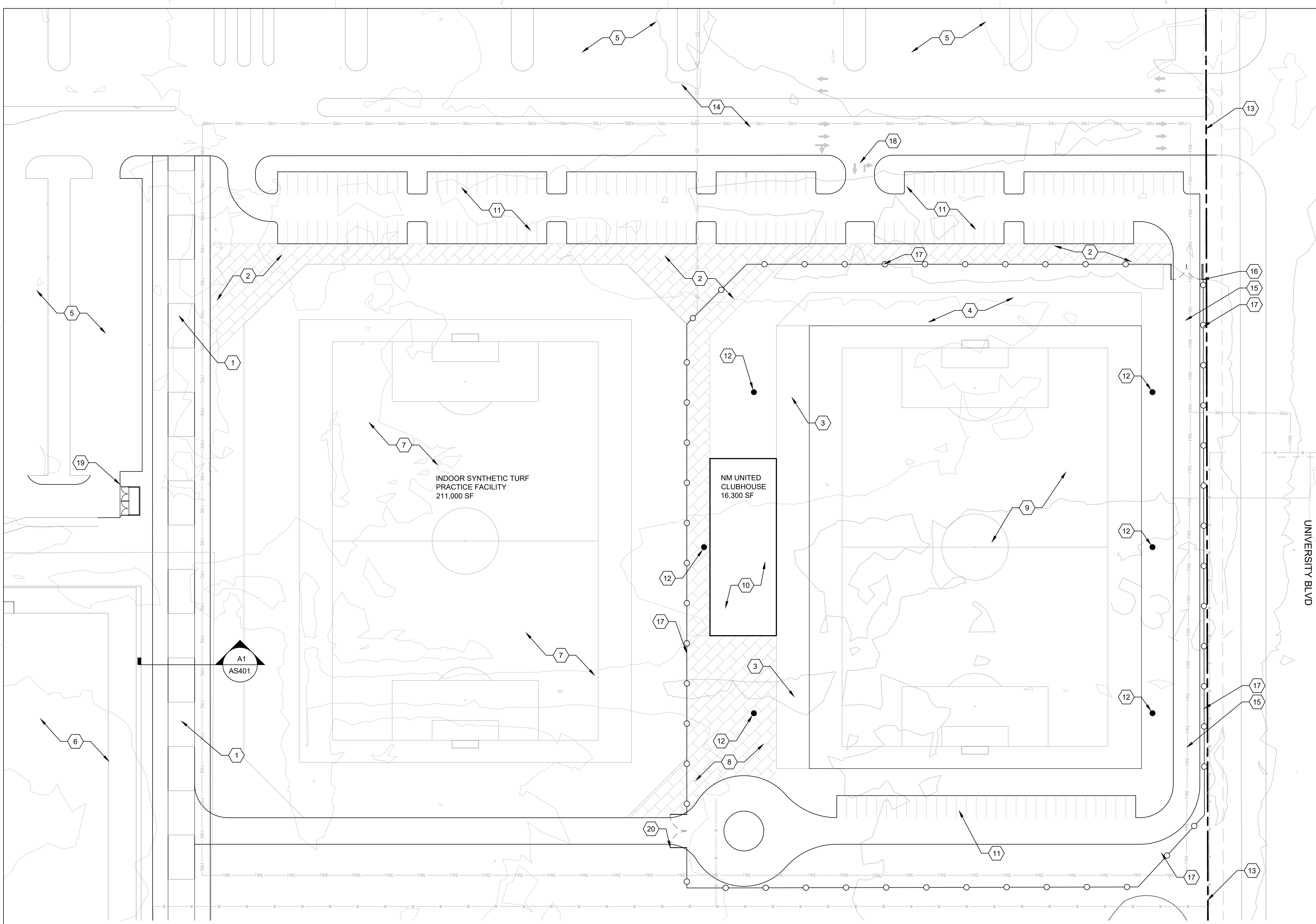

B1 SITE PLAN ENLARGEMENT - PHASE I
1" = 50'-0"
0 50' 100'

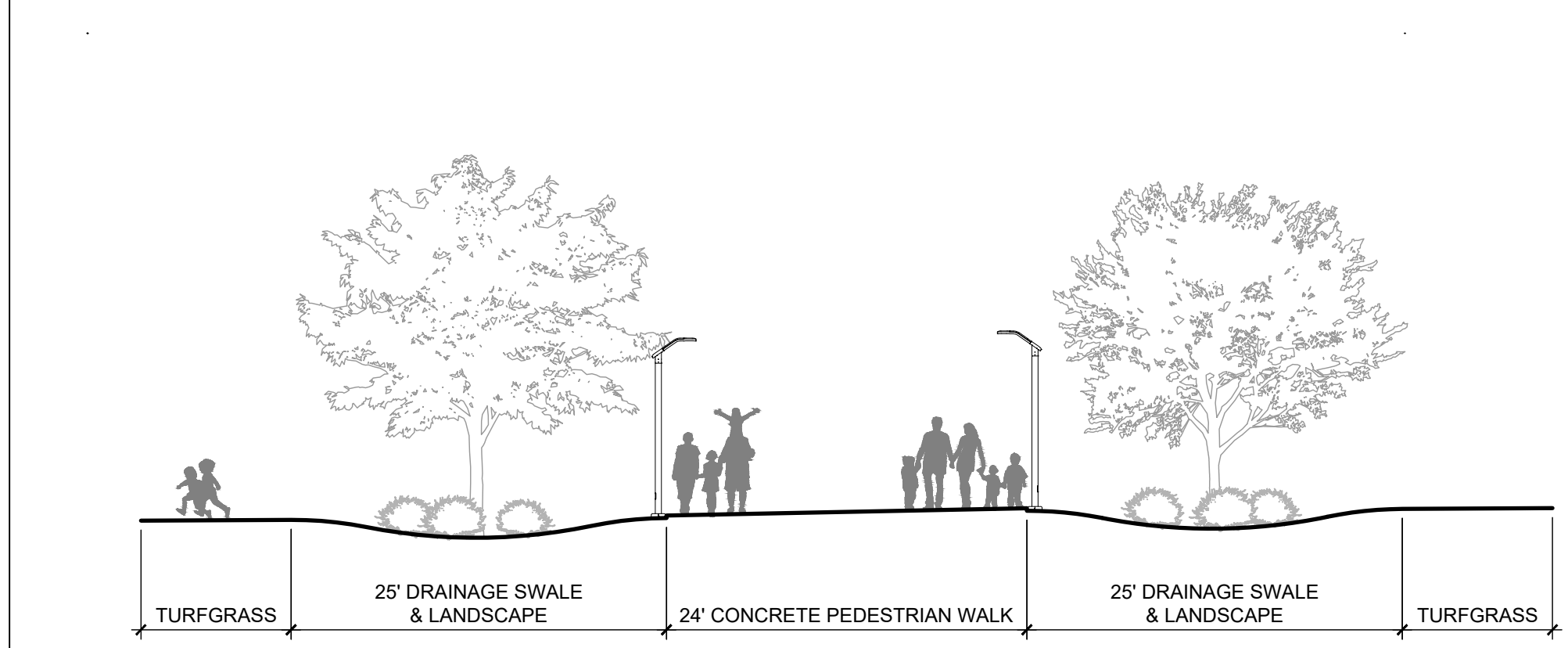

A1 SECTION - CENTRAL PEDESTRIAN PROMENADE
1" = 10'-0"
0 10' 20'

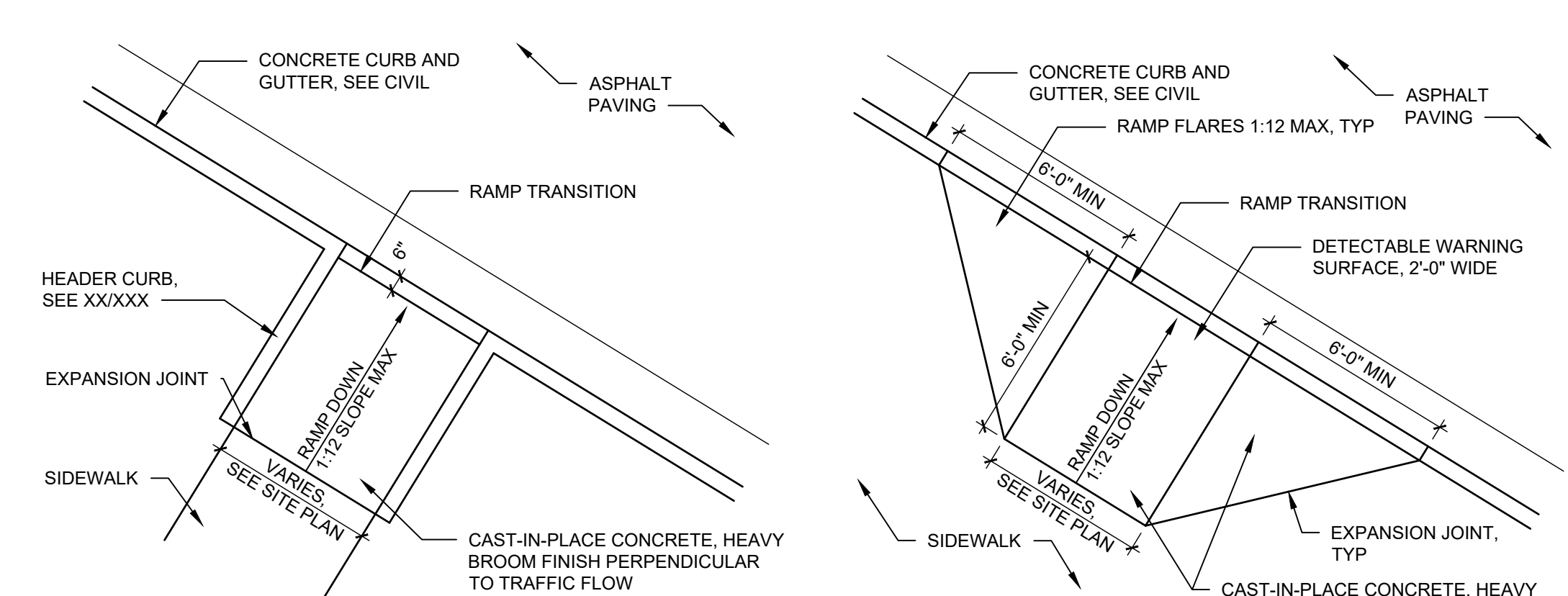

A2 ACCESSIBLE RAMPS
NTS

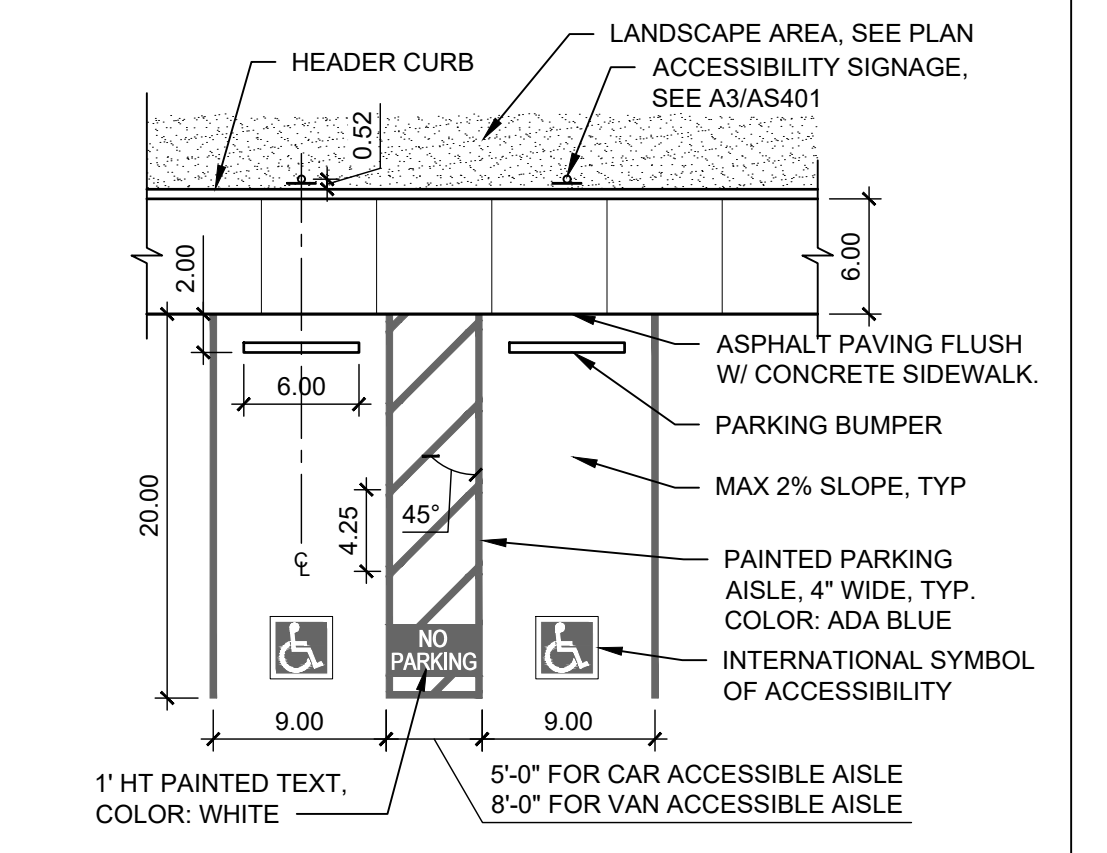

C4 ACCESSIBLE PARKING
NTS

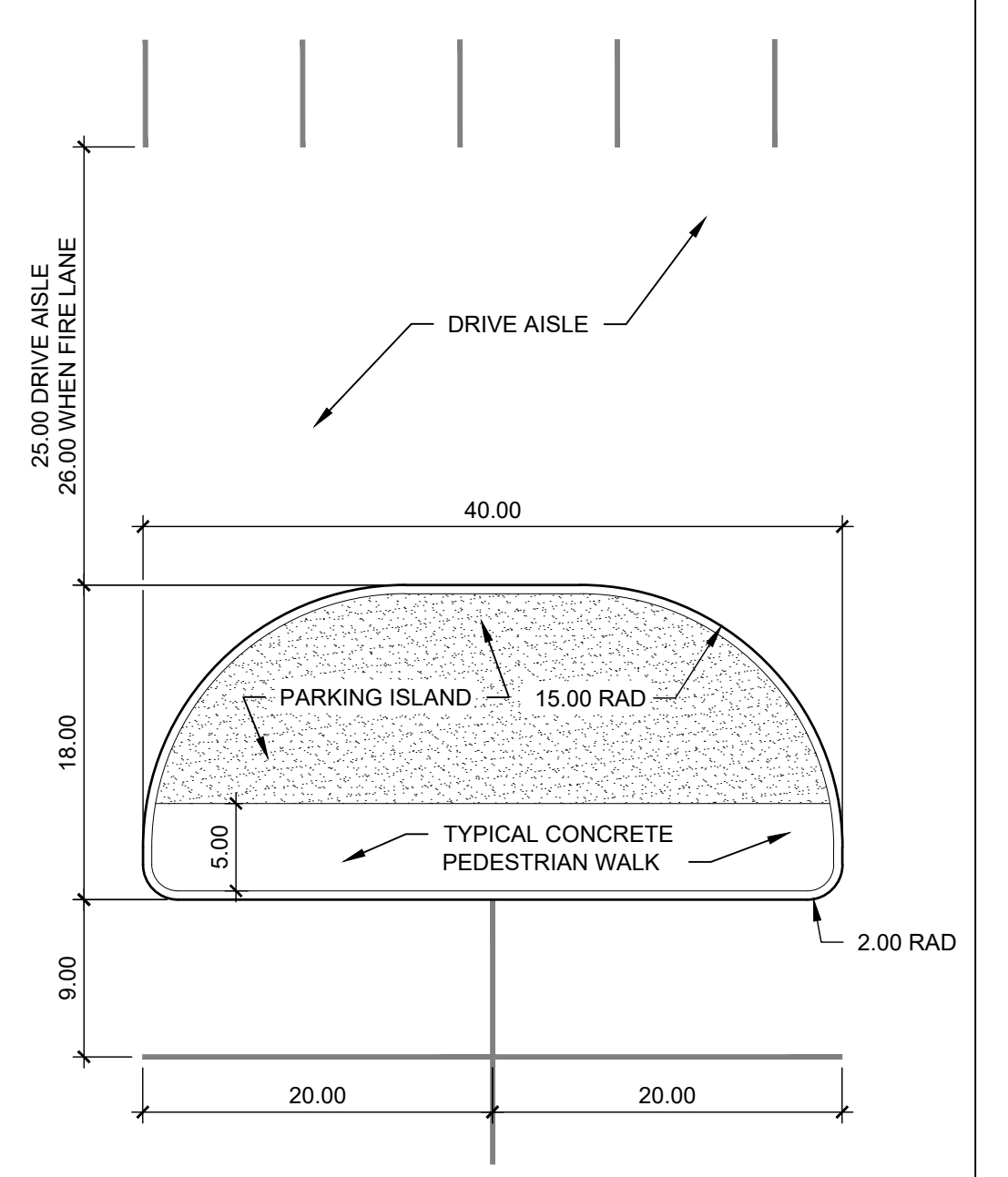

B4 TYPICAL PARKING ISLAND, STALL, AND DRIVE
NTS

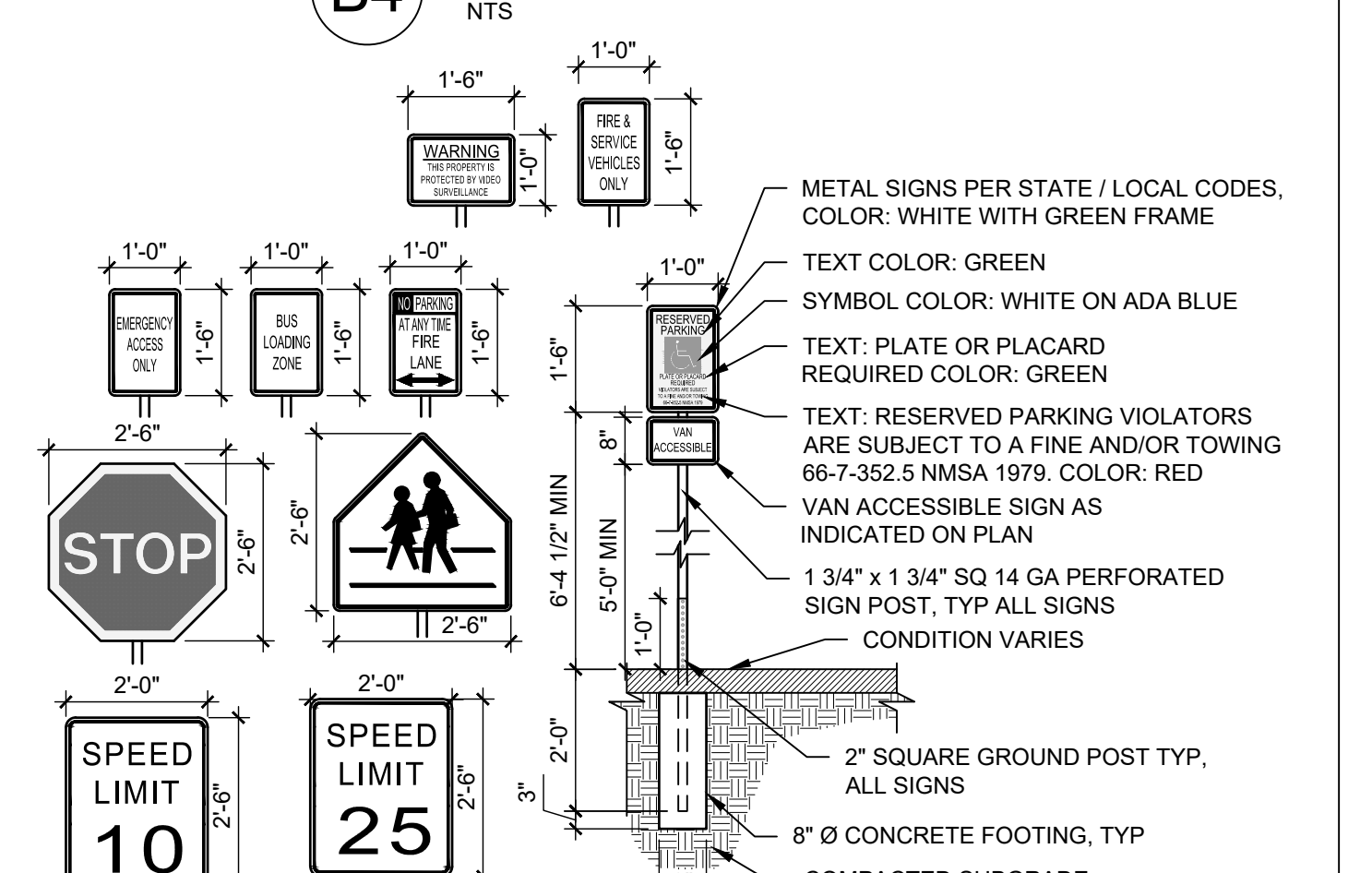

A4 SITE SIGNS
NTS

REVISIONS

- △
- △
- △
- △

DRAWN BY: BG
REVIEWED BY: KR
DATE: 10/30/19
PROJECT NO.: 17-0090.001
DRAWING NAME:

SITE PLAN ENLARGEMENT

SHEET NO. **AS401**
OF

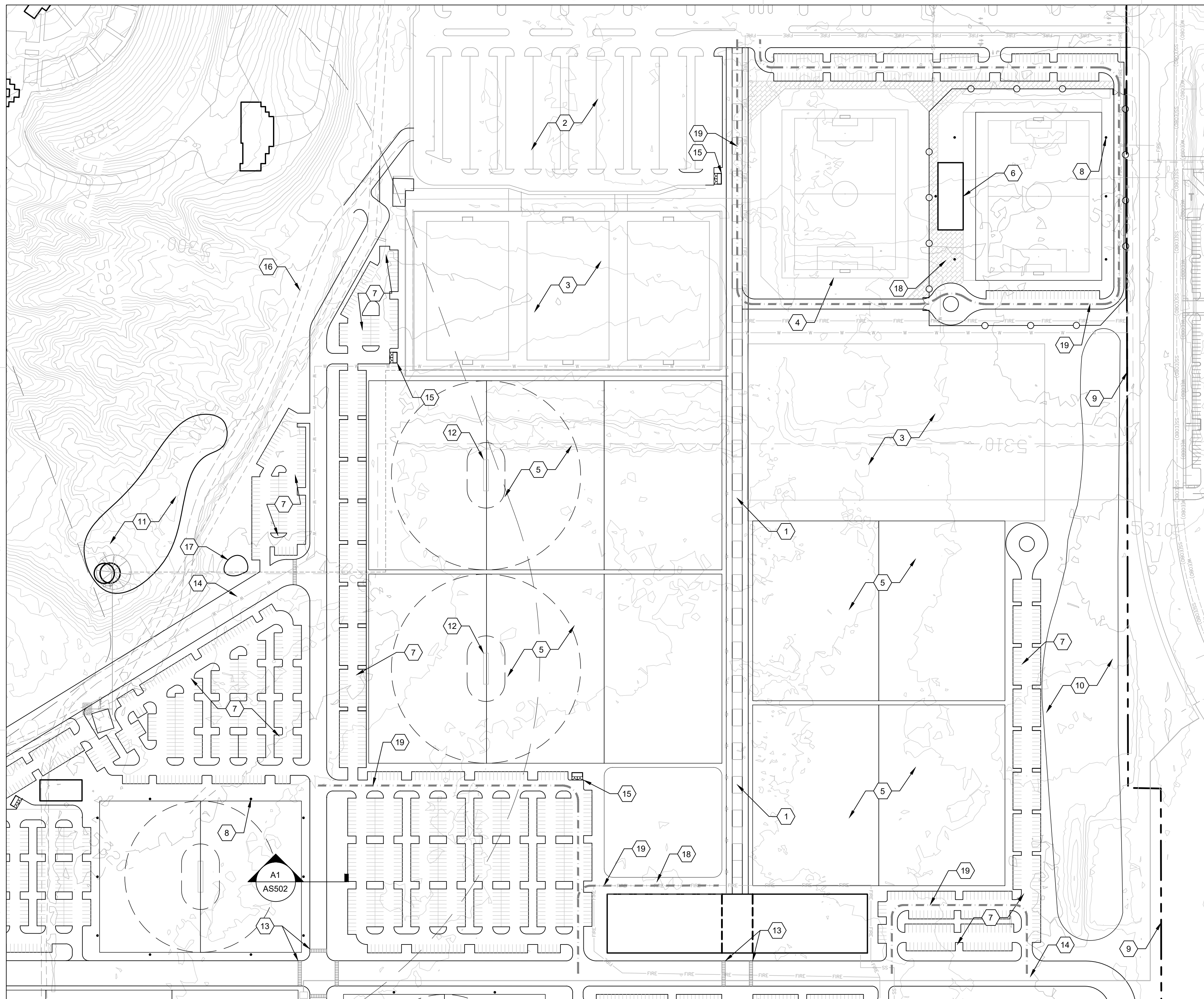

- ### SHEET KEYED NOTES
1. CONCRETE PEDESTRIAN WALK
 2. EXISTING PARKING
 3. EXISTING TURF GRASS MULTI-USE FIELDS
 4. FUTURE INDOOR PRACTICE FACILITY
 5. TURF GRASS PRACTICE FIELD
 6. NEW MEXICO UNITED CLUBHOUSE
 7. PROPOSED PARKING
 8. SPORT FIELD LIGHTING
 9. PROPERTY LINE
 10. STORMWATER RETENTION AREA
 11. MAINTENANCE YARD
 12. CRICKET PITCH
 13. CROSSWALK
 14. VEHICULAR ROADWAY
 15. TRASH ENCLOSURE, SEE A2/AS402
 16. EXISTING EASEMENT
 17. REMOTE CONTROL CAR PARK
 18. SERVICE AREA
 19. 26' WIDE FIRE LANE

**DEKKER
PERICH
SABATINI**

ARCHITECTURE
DESIGN
INSPIRATION

ARCHITECT

ENGINEER

PROJECT

BERNALILLO COUNTY REGIONAL
OUTDOOR SPORTS COMPLEX
5601 UNIVERSITY BLVD SE
ALBUQUERQUE, NM 87106

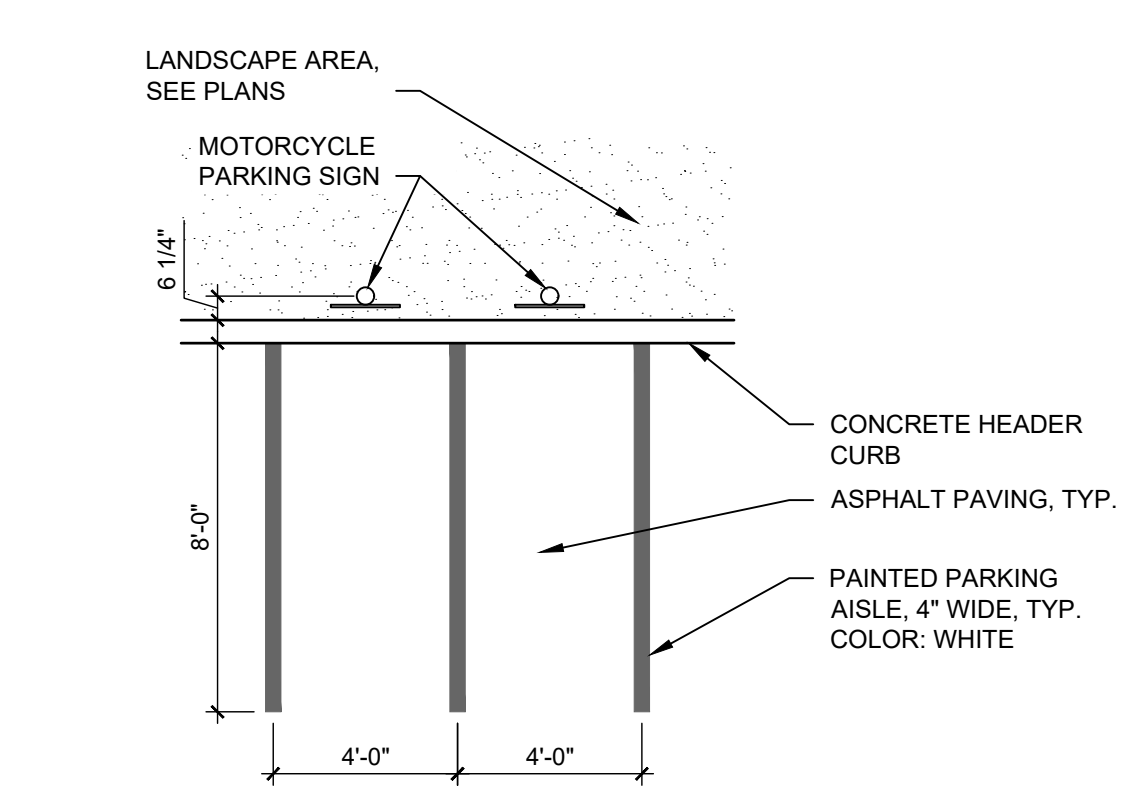

C4 MOTORCYCLE PARKING
NTS

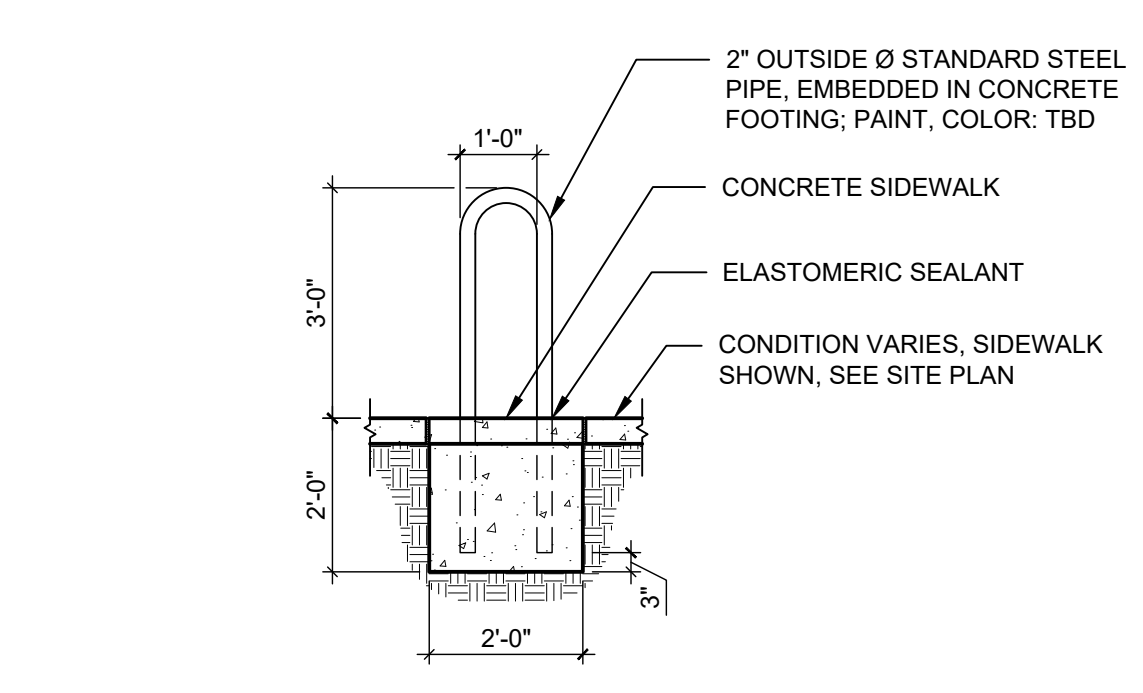

B4 BICYCLE RACKS
NTS

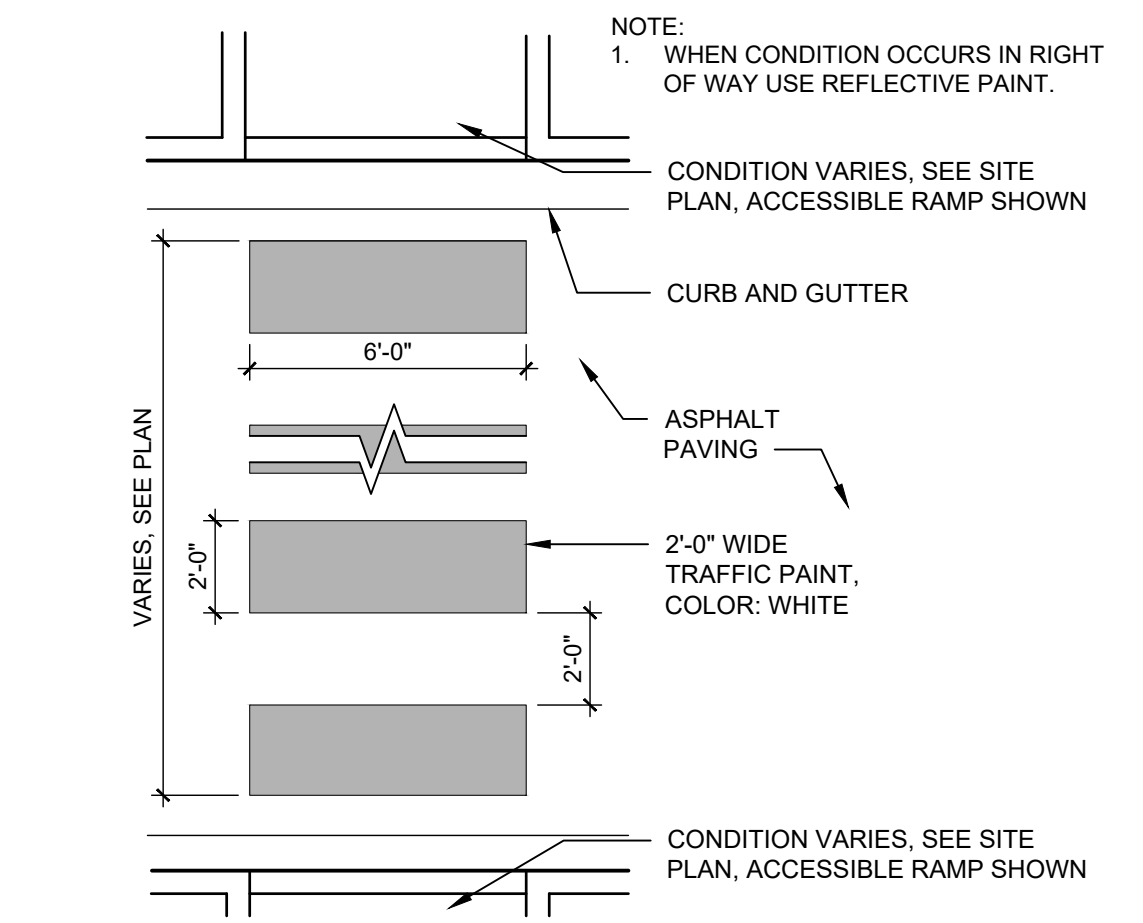

A4 PAINTED CROSSWALK
NTS

B1 SITE PLAN ENLARGEMENT - PHASE II
1" = 150'-0"

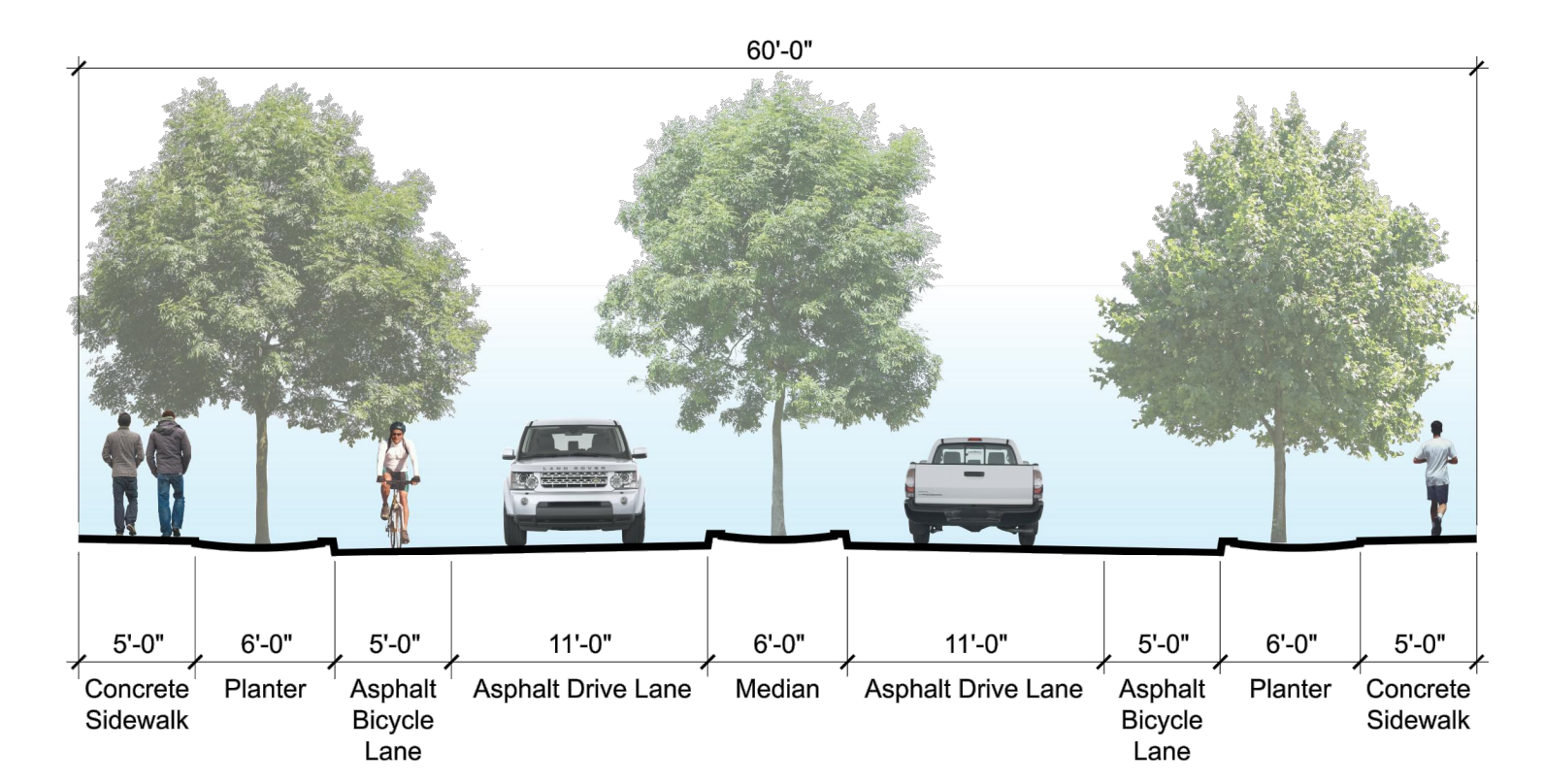

A1 TYPICAL ROAD SECTION
NTS

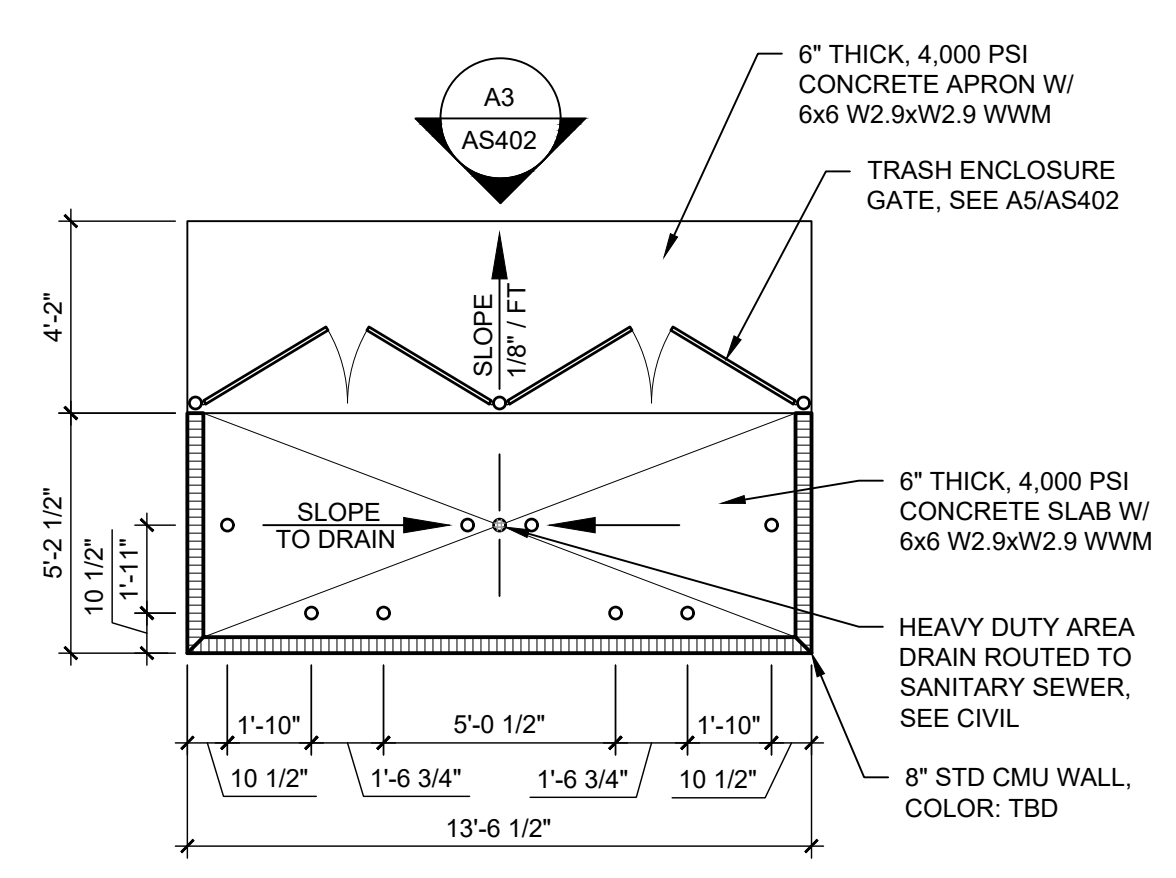

A2 TRASH ENCLOSURE PLAN
NTS

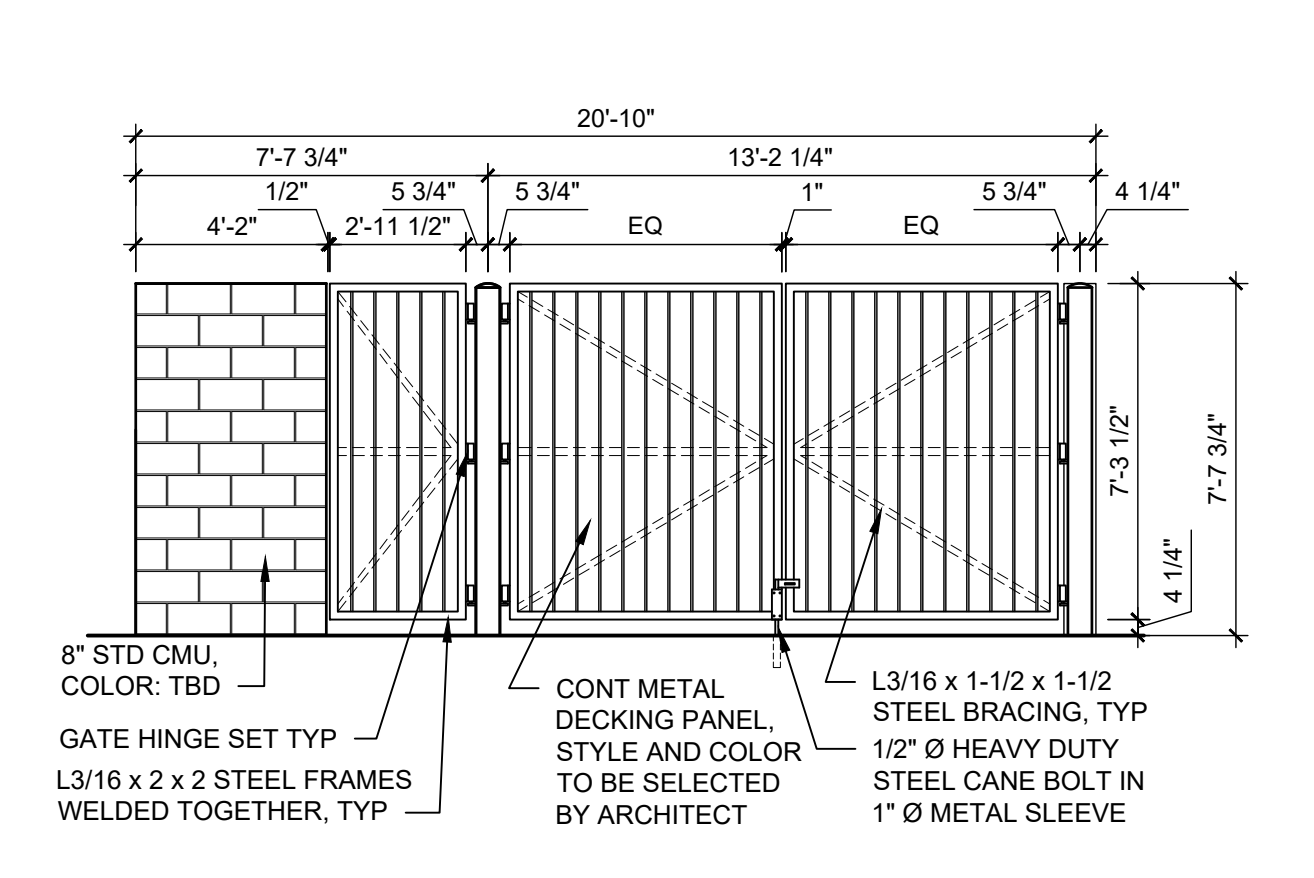

A3 TRASH ENCLOSURE ELEVATION
NTS

REVISIONS

△	
△	
△	
△	

DRAWN BY	BG
REVIEWED BY	KR
DATE	10/30/19
PROJECT NO.	17-0090.001
DRAWING NAME	

SITE PLAN
ENLARGEMENT

SHEET NO.
AS402
OF