

**1** ACCESSIBLE SIDEWALK RAMP  
SCALE: 1/4" = 1'-0"

**2** RAMP @ SIDEWALK  
SCALE: 1/4" = 1'-0"

**3** BICYCLE RACK  
SCALE: 1/2" = 1'-0"

**4** MOTOR CYCLE SIGN ELEVATION  
SCALE: 1/2" = 1'-0"

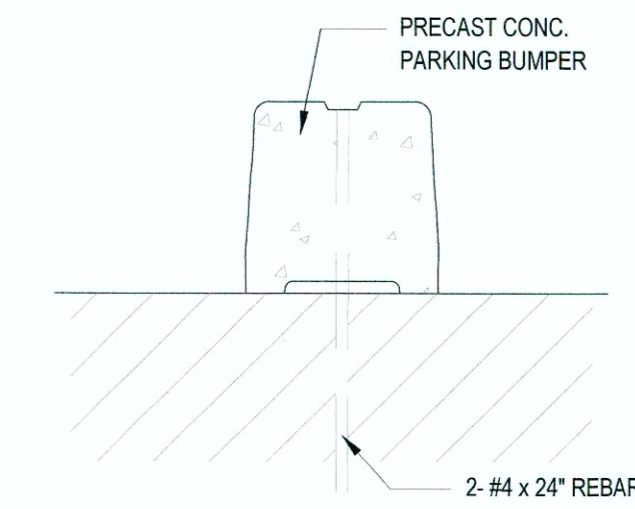
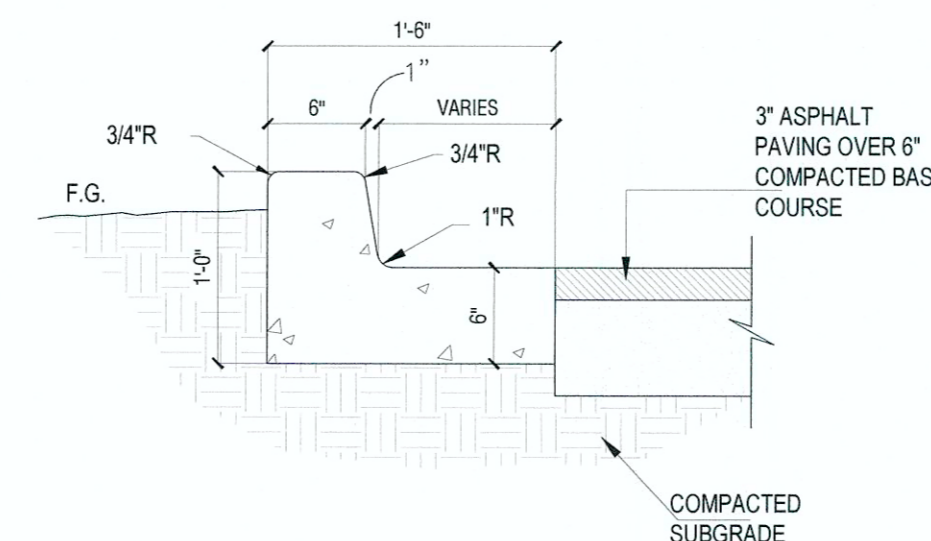
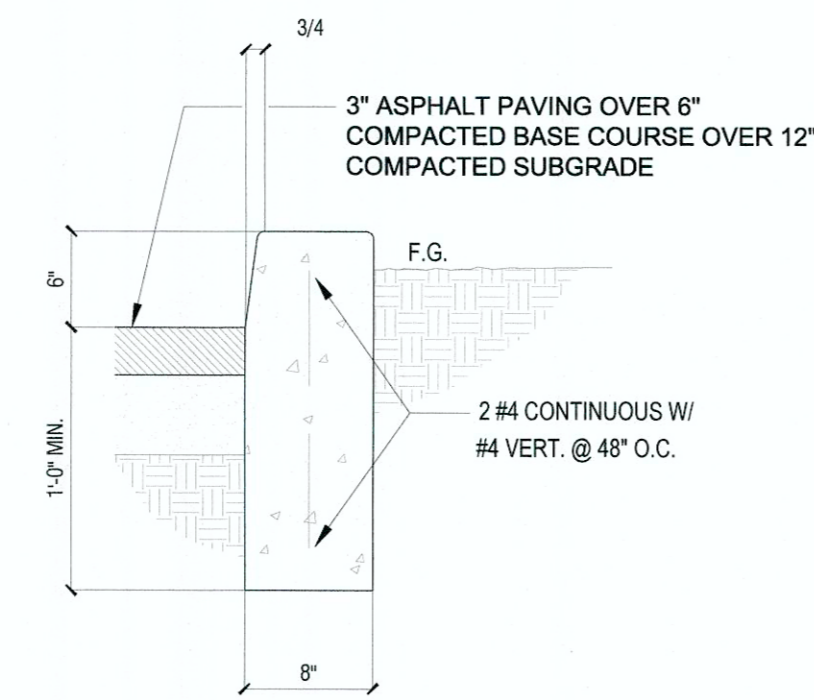
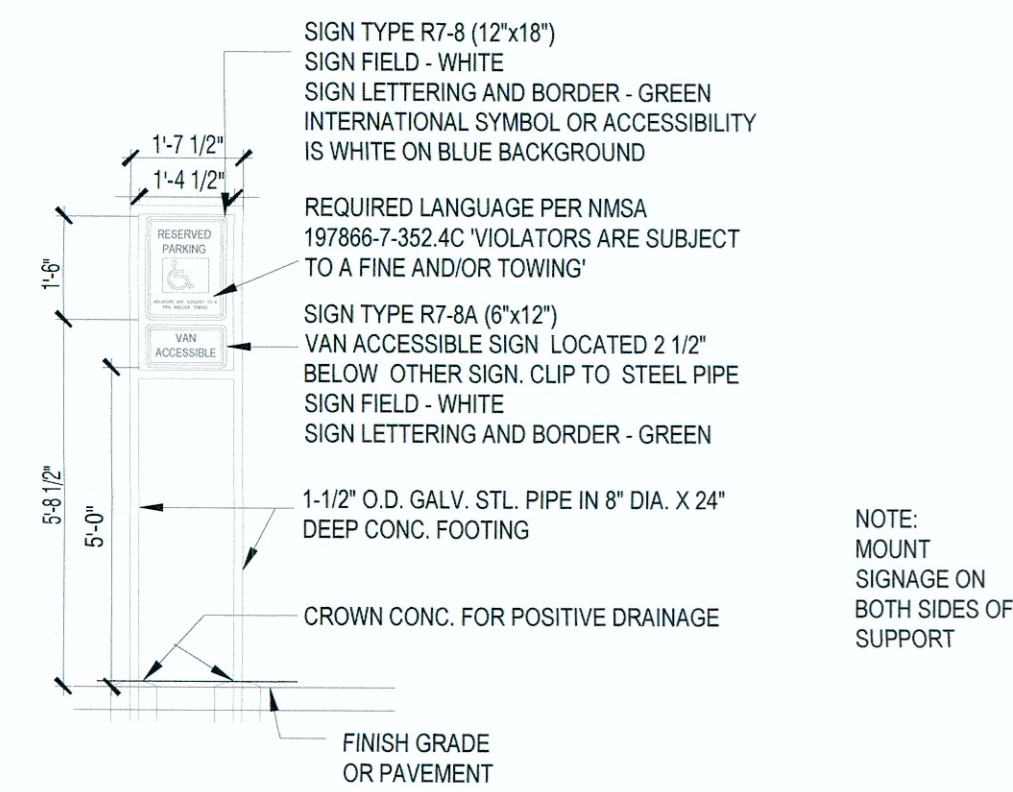

**4** ACCESSIBLE SIDEWALK RAMP  
SCALE: 1/4" = 1'-0"

**5** CURB DETAIL  
SCALE: 1" = 1'-0"

**6** CURB AND GUTTER  
SCALE: 1" = 1'-0"

**7** CONCRETE BUMPER  
SCALE: 1" = 1'-0"

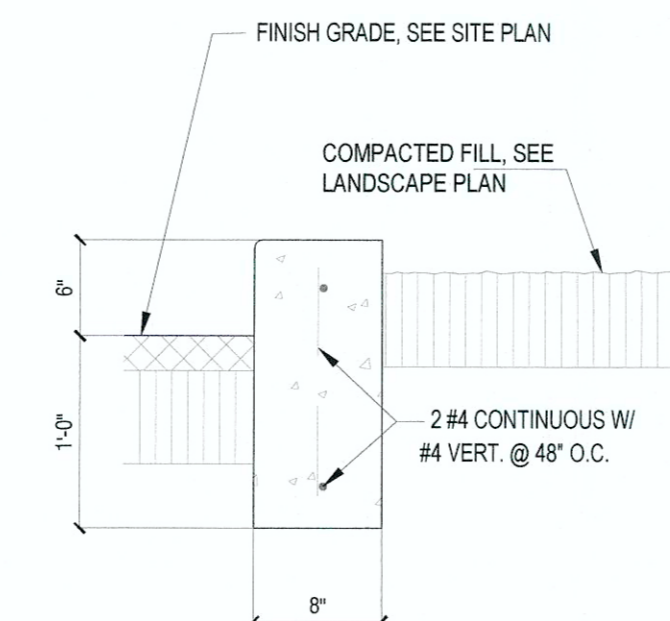
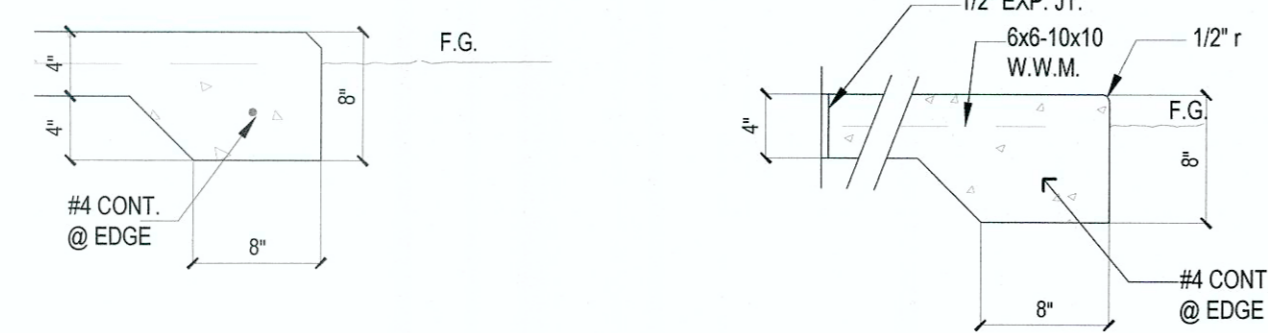
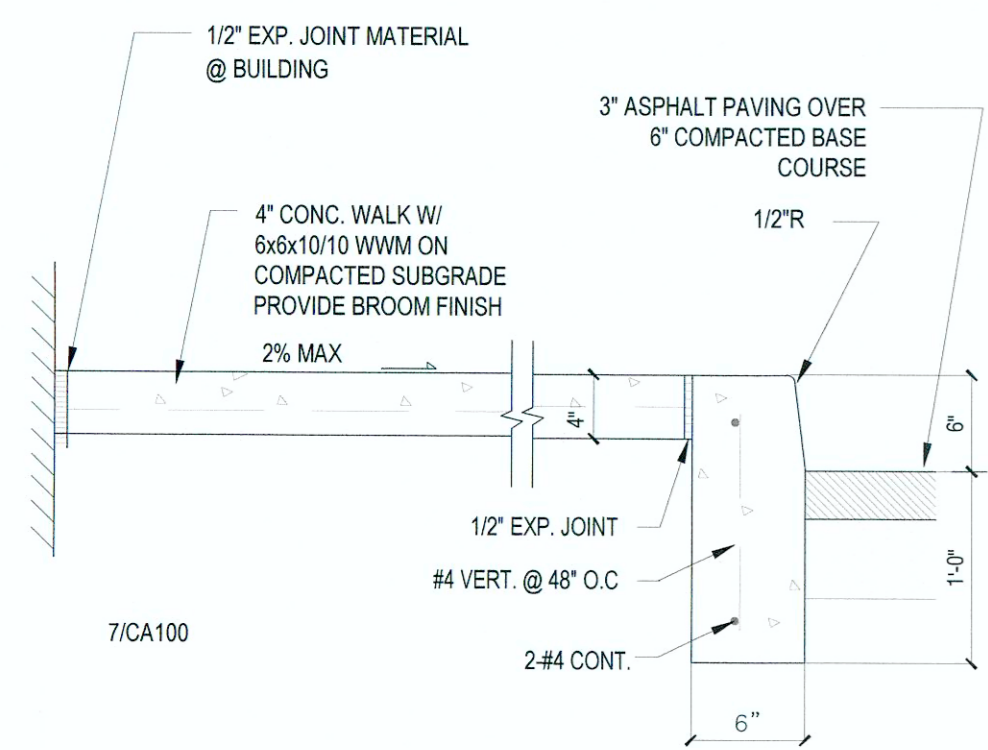

**8** CONCRETE WALK  
SCALE: 1" = 1'-0"

**9** CONCRETE SIDEWALK EDGE  
SCALE: 1" = 1'-0"

**10** CONCRETE CURB AT PLANTER  
SCALE: 1" = 1'-0"

No.	ISSUE DATE	PROJECT STATUS

DATE 2020.01.17

DRAWN BY SG

CHECKED BY DH

SCALE AS NOTED

PROJECT NO. B4 - 176 - 1901

SHEET NAME

**SITE DETAILS**

DRAWING NO.

**A1.3**