



Development Facilitation Team (DFT) – Review Comments

Reviewer: David G. Gutierrez, P.E. | Phone: 505-289-3381 | dggutierrez@abcwua.org

DRB Project No: PR-2020-003484 Date: 06/14/2023 Agenda Item: #4 Zone Atlas Page: E-10

Legal Description: Lots 2 & 3 Block 12 unit 3, Volcano Cliffs SUBD

Location: Mojave St NW between Unser Blvd and Tesuque Dr.

Application For: SD-2023-00048 – PRELIMINARY PLAT (DHO)

1. No objection

DEVELOPMENT HEARING OFFICER

TRANSPORTATION DEVELOPMENT

DRB Project Number: 2020-003484
6341 Mojave

AGENDA ITEM NO: 4

SUBJECT: Preliminary Plat

ENGINEERING COMMENTS:

1. I see the Grading and Drainage plan shows Colton St. as a separate tract in order to keep the scour wall out of the ROW. Please ensure this is on the plat that we are approving. No objection.

. If new or revised information is submitted, additional comments may be provided by Transportation Development.

FROM: Ernest Armijo, P.E.
Transportation Development
505-924-3991 or earmijo@cabq.gov

DATE: June 14, 2023

ACTION:

APPROVED __; DENIED __; DEFERRED __; COMMENTS PROVIDED __; WITHDRAWN __

DELEGATED: _____ TO: (TRANS) (HYD) (WUA) (PRKS) (CE) (PLNG)

DEVELOPMENT FACILITATIVE TEAM - HYDROLOGY SECTION
 Renée Brissette, PE, Senior Engineer | 505-924-3995 rbrissette@cabq.gov

DRB Project Number: 2020-003484 Hearing Date: **06-14-2023**
 Project: Mojave Ridge Subdivision Agenda Item No: 4

<input type="checkbox"/> Sketch Plat	<input type="checkbox"/> Minor Preliminary / Final Plat	<input checked="" type="checkbox"/> Preliminary Plat	<input type="checkbox"/> Final Plat
<input type="checkbox"/> Temp Sidewalk Deferral	<input type="checkbox"/> Sidewalk Waiver/Variance	<input type="checkbox"/> Site Plan for Bldg. Permit <input type="checkbox"/> Site Plan for Subdivision	<input type="checkbox"/> Bulk Land Plat
<input type="checkbox"/> SIA Extension	<input type="checkbox"/> DPM Variance	<input type="checkbox"/> Vacation of Public Easement	<input type="checkbox"/> Vacation of Public Right of Way

ENGINEERING COMMENTS:

- Hydrology has an approved Revised Grading & Drainage Plans (E10D024) with engineer's stamp date of 05/15/23.
- Hydrology needs approvals from National Parks and Open Space.

RESOLUTION/COMMENTS:

Water:

Code Enforcement:

Parks:

Transportation:

Planning:

APPROVED
 DENIED

DELEGATED TO: TRANS HYD WUA PRKS PLNG
 Delegated For: _____
 SIGNED: I.L. SPSD SPBP FINAL PLAT
 DEFERRED TO _____

DEVELOPMENT HEARING OFFICER

Code Enforcement Comments

Disclaimer: Comments provided are based upon information received from applicant/agent. If new or revised information is submitted, additional comments may be provided by Planning staff.

Jeff Palmer-Code Enforcement Supervisor
Planning Department
jppalmer@cabq.gov

DATE: 6/14/2023

AGENDA ITEM NO: 4

DHO PROJECT NUMBER:

PR-2020-003484

SD-2023-00048 – PRELIMINARY PLAT

SKETCH PLAT 1-11-23 (DFT)

IDO - 2021

PROJECT NAME:

THE GROUP | RON HENSLEY agent for **NAFEESA PASHTOON** requests the aforementioned action(s) for all or a portion of: **LOTS 2 & 3 BLOCK 12 UNIT 3, VOLCANO CLIFFS SUBD** zoned **R1-D** located on **MOJAVE ST NW between UNSER BLVD and TESUQUE DR** containing approximately **4.25** acre(s). (E-10) [Deferred from 4/12/23, 4/26/23b, 5/10/23b, 5/24/23b]

PROPERTY OWNERS: PASHTOON NAFEESA

REQUEST: CREATE 19 LOTS FROM EXISTING TRACTS

COMMENTS: (Deferred prior to 5/24 Hearing to 6/14/23):

1. Property is located within 330 feet of a Major Public Open Space, and it appears to meet the buffer requirements for the proposed development as per IDO 5-2(J)(2)(a)(1). However, since the IDO indicates these buffers must be approved by the Open Space Superintendent, Code Enforcement would like to confirm Parks is in agreement with this determination. These required landscape buffer areas should be clearly marked and noted on the plat, as discussed in 5/10/23 Hearing.

From: [Rodenbeck, Jay B.](#)
To: [Gomez, Angela J.](#)
Cc: [Wolfley, Jolene](#)
Subject: FW: [EXTERNAL] RE: PR #3484 Mojave Subdivision - National Park Service Comments
Date: Monday, June 12, 2023 12:47:17 PM
Attachments: [image001.png](#)
[SANITARY SEWER MANHOLE DWG 2102.pdf](#)
[section 900 sewer.pdf](#)

Hi Angela,

Could you please file the attached message into the project folder for PR-2020-003484 in DMDview. It's an important email .

Thanks,

Jay

From: Hendricks, Nancy E <Nancy_Hendricks@nps.gov>
Sent: Monday, June 12, 2023 12:38 PM
To: ron@thegroup.cc; Thacker, Charles M <Charles_Thacker@nps.gov>
Cc: Keffer, Tricia M. <tkeffer@cabq.gov>; Langan-McRoberts, Colleen <cmcroberts@cabq.gov>; Rodenbeck, Jay B. <jrodenbeck@cabq.gov>; Biazar, Shahab <sbiazar@cabq.gov>; Wolfley, Jolene <jwolfley@cabq.gov>; Walter, Chanteil G <Chanteil_Walter@nps.gov>
Subject: Re: [EXTERNAL] RE: PR #3484 Mojave Subdivision - National Park Service Comments

[EXTERNAL] Forward to phishing@cabq.gov and delete if an email causes any concern.

Hi Ron and everyone,

I believe a good next step would be to meet on site with Ron, the NPS, and the City to better understand what this connection would entail. That way the NPS and City can assess the potential effects and compliance and permitting pathway more accurately. We don't have enough information about the actual work involved at this time.

I'm asking Chanteil Walter from Petroglyph to work with Ron to set up a meeting on-site including any interested City staff.

Mahalo,

Nancy

Nancy Hendricks, *Acting Superintendent*
Kaloko-Honokōhau National Historical Park (KAHO)

Pu'uhonua o Hōnaunau National Historical Park (PUHO)
73-4786 Kanalani St. #14
Kailua-Kona 96740-2600

(808) 329-6881 x 1201 (KAHO)
(808) 328-2326 x 1101 (PUHO)

From: ron@thegroup.cc <ron@thegroup.cc>

Sent: Friday, May 19, 2023 6:53 AM

To: Hendricks, Nancy E <Nancy_Hendricks@nps.gov>

Cc: tkeffer <tkeffer@cabq.gov>; 'Langan-McRoberts, Colleen' <cmcroberts@cabq.gov>; jrodenbeck@cabq.gov <jrodenbeck@cabq.gov>; sbiazar@cabq.gov <sbiazar@cabq.gov>; 'Jolene WOLFLEY' <jwolfley@cabq.gov>; Walter, Chanteil G <Chanteil_Walter@nps.gov>

Subject: [EXTERNAL] RE: PR #3484 Mojave Subdivision - National Park Service Comments

This email has been received from outside of DOI - Use caution before clicking on links, opening attachments, or responding.

Ms. Hendricks,

The existing sanitary sewer line is constructed within a Public Easement and is not within the physical arroyo. The 10 feet of sewer line and manhole will be constructed under the Standard Specifications The City Standard Drawings and Specifications of the connection are available and are attached. This "Public Easement" existed prior to the creation of the monument. Your opinion revokes the public interest in the easement without regard for Act. The 2023 Cooperative Management Agreement was intended for the Visitor Center and access and can't amend Federal Legislation.

PETR PL 101-313:

SEC. 107. EXISTING TRANSMISSION OR DISTRIBUTION FACILITIES.

Nothing in this title shall be construed as authorizing or requiring revocation of any interest or easement for existing transmission or distribution facilities or prohibiting the operation and maintenance of such facilities within or adjacent to the monument boundary.

I believe you have completely disregarded the establishing legislation, and you have offered several legal opinions on property rights. Are these opinions being provided as sworn statements?

You opinions and the process you have proposed is excessively burdensome and presents significant hardship to the owner. The owners rights in property and public easement access are being revoked.

The sewer connection proposed presents no impact to the Monument.

Sincerely,

Ron E. Hensley P.E.

505-410-1622



ron@thegroup.cc

From: Hendricks, Nancy E <Nancy_Hendricks@nps.gov>

Sent: Friday, May 19, 2023 9:47 AM

To: ron@thegroup.cc

Cc: tkeffer <tkeffer@cabq.gov>; Langan-McRoberts, Colleen <cmcroberts@cabq.gov>; jrodenbeck@cabq.gov; sbiazar@cabq.gov; Jolene WOLFLEY <jwolfley@cabq.gov>; Walter, Chanteil G <Chanteil_Walter@nps.gov>

Subject: PR #3484 Mojave Subdivision - National Park Service Comments

United States Department of the Interior

NATIONAL PARK SERVICE
Petroglyph National Monument
6001 Unser Blvd NW
Albuquerque, New Mexico 87120

IN REPLY REFER TO:
I.A.1.

May 19, 2023

Mr. Ron Hensley
The Hensley Engineering Group
Email: ron@thegroup.cc

Re: 2020-003484 Mojave Ridge Subdivision Supplemental Submittal

Mr. Hensley,

I am writing on behalf of the National Park Service (NPS) concerning the proposed sewer line at the Mojave Ridge Subdivision. It is our understanding that you are proposing to connect the housing development sewer line to an existing sewer line within Petroglyph National Monument (Monument). The connecting sewer line would be constructed through the Boca Negra Canyon Arroyo and would be connected to an existing sewer line located in a City of Albuquerque Municipal Development Easement. The Boca Negra Canyon Arroyo itself appears to be outside the City easement but is within the Monument boundary and is city-owned Open Space land.

At the May 10, 2023, Development Hearing Officer meeting, the NPS and City of Albuquerque Open Space Division requested additional information from you related to this proposal, including the details of the intended construction within the arroyo. In an email dated May 15, 2023, you provided the grading plan for the subdivision. This plan did not include any detailed information on the proposed sewer line connection.

We request more information on the proposed sewer line to allow us to evaluate this project in accordance with federal law and policy. This project would be considered a new right-of-way (ROW) within Petroglyph National Monument and as such, it would require the submittal of a ROW permit application. Since it is located on Major Public Open Space, per the 2023 Cooperative Management Agreement (CMA) between the NPS and the City of Albuquerque (Article II (3) h), you would be required to obtain a permit with the City of Albuquerque for this work per CMA Article II (3) h.: *Right-of-Way (ROW) permits for existing ROWs and easements will be authorized by the appropriate land management agency depending on the land ownership status. New ROW permits and/or projects related to the construction of new utilities, water/wastewater, telecommunications facilities, drainage, or similar projects will be reviewed per Article I. (3).* This permit is discretionary, is revocable, and does not convey or imply any interest in the land. You would work with the City of Albuquerque to obtain this permit. Please follow up

with the City Planning Department to identify the permitting requirements.

In addition, because this land falls within the boundary of Petroglyph National Monument, you would be required to obtain a permit from the National Park Service. The first step in the permitting process is to submit a SF-299 Application Form. Once we receive all the required information on this project, the NPS would analyze the proposal in accordance with federal laws and policies.

In addition to the SF-299 application form, please submit detailed drawings of the proposed sewer line, construction documents providing information on the depth, width, and length of the trench needed for the placement of the pipe, the dimensions of the pipe, what type of equipment would be used, duration and timing of the work, how much of the line would actually be within the Monument boundary, access and staging areas for construction, and how the line would be protected from spills/breakage since it would be located within the arroyo.

Locating a sewer line in an arroyo is a concern to us. We urge you to consider other options outside the Monument boundary. Have you considered connecting the development sewer line into the main line that is located within the Mojave Street NW corridor? What is your justification for connecting to the sewer line through the arroyo, and not connecting to the existing sewer lines located within the adjacent city street?

Per the 1990 Establishment Legislation for Petroglyph National Monument (Public Law 101-313), the Monument is administered, managed, and protected in accordance with the National Park Service Organic Act in such a manner as to preserve, for the benefit and enjoyment of present and future generations, its cultural and natural resources. Our primary mandate is to preserve the cultural and natural resources within the Monument, thus all proposals for construction within the Monument must be assessed through this lens.

The Establishment Legislation further states that federal laws generally applicable to units of the National Park System, including but not limited to, the National Environmental Policy Act, shall apply to the monument. The CMA affirmed this process.

Article I (3): Proposed projects on federally and City-owned lands within the Monument boundaries will be assessed following NPS guidelines for compliance with applicable federal laws, including, but not limited to, the National Environmental Policy Act, the National Historic Preservation Act; and other applicable federal, state, and local laws and regulations. Consultation and collaboration with traditionally associated Pueblos and Tribes and the State Historic Preservation Office will be an on-going standard practice.

All construction inside the Monument is subject to 36 C.F.R. 5.7, which states:

"Constructing or attempting to construct a building, or other structure, boat dock, road, trail, path, or other way, telephone line, telegraph line, power line, or any other private or public utility, upon across, over, through, or under any park areas, except in accordance with the provisions of a valid permit, contract, or other written agreement with the United States, is prohibited."

For the NPS to review the proposed work within the Monument's boundary, on lands owned by the City of Albuquerque Open Space Division, you must provide a written request containing information that would allow the NPS to analyze the proposal per federal law. We would also initiate Tribal Consultation for the proposed project pursuant to the National Environmental Policy Act and Section 106 of the National Historic Preservation Act (36 CFR 800.2). The environmental and cultural review processes may take several months and require additional steps related to proposed construction in an arroyo.

Also, 54 U.S.C. § 1031042 authorizes the NPS to recover and retain all costs of providing necessary services associated with special use permits including costs associated with environmental and cultural reviews, as well as all agency costs incurred in monitoring or associated with managing the permitted

activity if the request is approved.

Until we work through these processes, we cannot endorse this proposed work within Petroglyph National Monument.

If you would like to discuss further or need additional information, please contact me at Nancy_hendricks@nps.gov and we can set up a meeting with our Regional staff who would assist us in this process.

Sincerely,

Nancy Hendricks
Superintendent

[Standard Form 299 - Application for Transportation, Utility Systems, Telecommunications and Facilities on Federal Lands and Property \(nps.gov\)](#)

Cc:
City of Albuquerque Open Space
City of Albuquerque Planning Department
City of Albuquerque Development Hearing Officer

05/16/2023

Mr. Hensley,

On 005/05/2023 the **National Park Service (NPS)** received your **Freedom of Information Act (FOIA)** request, dated 05/05/2023, and assigned it control number **DOI -NPS-2023-004394**. Please cite this number in any future communications with our office regarding your request.

We have classified you as an “other-use” requester. As such, we may charge you for some of our search and duplication costs, but we will not charge you for our review costs; you are also entitled to up to 2 hours of search time and 100 pages of photocopies (or an equivalent volume) for free. See [43 C.F.R. §2.39](#). If, after taking into consideration your fee category entitlements, our processing costs are less than \$50.00, we will not bill you because the cost of collection would be greater than the fee collected. See [43 C.F.R. §2.37\(g\)](#).

“Do what you can, with what you have, where you are.”

-Theodore Roosevelt

Alison Yamato

Government Information Specialist

NPS FOIA Officer - Intermountain Region

Department of Interior Regions 6, 7 & 8

12795 W Alameda Pkwy

Lakewood, CO 80228

From: [Wolfley, Jolene](#)
To: [Gomez, Angela J.](#)
Cc: [Chen, Tiequan](#)
Subject: PR #3484 FW: DOI-NPS-2023-004394 Request
Date: Friday, June 9, 2023 7:42:01 AM
Attachments: [image001.png](#)
[NPS Acknowledgment Letter.pdf](#)

Please add to the file for this case.

From: ron@thegroup.cc <ron@thegroup.cc>
Sent: Tuesday, May 16, 2023 5:21 PM
To: Wolfley, Jolene <jwolfley@cabq.gov>
Cc: Biazar, Shahab <sbiazar@cabq.gov>
Subject: FW: DOI-NPS-2023-004394 Request

[EXTERNAL] Forward to phishing@cabq.gov and delete if an email causes any concern.

I expect the Petroglyph National Monument Roadway/Utility Corridors to provide further direction on construction in the utility easement and drainage corridor, but the City has not been able to provide the document as required. Therefore, I wanted to forward my FOIA request for the Petroglyph National Monument Roadway/Utility Corridors to the Dept. of Interior. I will share the document when it is received.

Ron E. Hensley P.E.
505-410-1622



ron@thegroup.cc

From: npsfoia@email.doi.gov <npsfoia@email.doi.gov>
Sent: Tuesday, May 16, 2023 6:31 AM
To: ron@thegroup.cc
Cc: alison_yamato@nps.gov
Subject: DOI-NPS-2023-004394 Request

05/16/2023

Mr. Hensley,

On 005/05/2023 the **National Park Service (NPS)** received your **Freedom of Information Act (FOIA)** request, dated 05/05/2023, and assigned it control number **DOI -NPS-2023-004394**. Please cite this number in any future communications with our office regarding your request.

We have classified you as an “other-use” requester. As such, we may charge you for some of

our search and duplication costs, but we will not charge you for our review costs; you are also entitled to up to 2 hours of search time and 100 pages of photocopies (or an equivalent volume) for free. See [43 C.F.R. § 2.39](#). If, after taking into consideration your fee category entitlements, our processing costs are less than \$50.00, we will not bill you because the cost of collection would be greater than the fee collected. See [43 C.F.R. § 2.37\(g\)](#).

"Do what you can, with what you have, where you are."

-Theodore Roosevelt

Alison Yamato

Government Information Specialist

NPS FOIA Officer - Intermountain Region

Department of Interior Regions 6, 7 & 8

12795 W Alameda Pkwy

Lakewood, CO 80228



Development Hearing Officer Planning - Case Comments

Meeting Date: 6/14/23 -- **DHO AGENDA ITEM #4**

Project Number: PR-2020-003484

Application Number: SD-2032-00048

Project Name: 6341 Mojave St NW

Request:

Preliminary Plat for 19 residential lots.

**These are preliminary Planning comments. Additional reviews and/or revised comments may be needed for any modifications and/or supplemental submittals.*

Items in red need to be addressed for the application to move forward.

COMMENTS:

1. Items that Need to be Completed or Corrected:

- **Updated 6.14.23:** Planning recommends a deferral of the application to June 28th pending an on-site meeting requested by the National Park Service (NPS) and City Open Space to determine future construction impacts resulting from this subdivision. Based on information gleaned in this meeting, the NPS will determine the federal approval process they sense is warranted. The applicant has provided a new plat that moves the scour wall 6 feet into the private parcel. This should allow scour wall construction that does not affect the National Monument. However, the issue of connecting the subdivision sewer line to the sewer line in the Boca Negra Arroyo has not been discussed and there is a lack of the agreement between the applicant and NPS/City Open Space. The NPS had asked for general construction documents to show details of trenching, etc. and the applicant did not provide that information. The NPS has requested an on-site meeting to give clarity to the construction needs and to determine the federal approval process that would be warranted.

As of 5.9.23: The applicant and staff of the NPS, City Open Space, City Planning and the City Engineer met circa 4.21.23. Both the NPS and COA Open Space clearly explained a private party would need to ask permission for a scour wall, a sewer connection, and/or an outflow from a drainage pond to the Boca Negra Arroyo drainage area. In the resubmittal, the applicant reworked the scour wall so that is on the private

**(See additional comments on next page)*

property side of the property line with the Arroyo. The applicant has not provided any documentation of having requested permission from the NPS or COA Open Space regarding the location of that scour wall, the connection to the sewer, and the outflow from the drainage pond to the Arroyo. Planning staff cannot recommend proceeding with the review and approval of this subdivision because of the IDO indicates that outside agencies have review rights and federal law must be followed. **See the following IDO provisions:**

1-8(D) If any regulation in this IDO conflicts with other applicable laws or regulations of the City, or conflicts with applicable State or federal law, the more restrictive provision shall prevail, unless the provisions of State or federal law, as interpreted by the courts, prevent that result.

6-4(J) REFERRALS TO COMMENTING AGENCIES

Following a determination that the application is complete, the Planning Director, ZEO, or any City staff designated to review applications in Table 6-1-1 shall refer applications for comment to the following departments or agencies, as noted below. Any comments received within 15 calendar days after such a referral shall be considered with the application materials in any further review and decision-making procedures.

6-4(J)(1) General

City departments or agencies or other governmental or quasi-governmental agencies whose services, properties, facilities, interests, or operations may be affected.

6-4(J)(6) Development within 660 feet of the Petroglyph National Monument

6-4(J)(6)(a) National Park Service.

6-4(J)(6)(b) Open Space Division of the City Parks and Recreation Department.

- **Updated 6.12.23** The Infrastructure list 'Notes/Drainage' needs to add the word "Standard" in front of "specification ."
- **Updated 5.9.23:** Landscaping is to follow Standard Specification 1013 and is noted on the Infrastructure List.
~~Tract A: Is there a landscaping Plan for Tract A? Any Landscape Plans must be sealed and signed by a Landscape Architect licensed in the State of New Mexico.~~
Updated 6.12.23 Change the maintenance note of Tract A (pond) to be the Homeowner's Association, not just 'owner'; city maintenance is not provided for Tract A.
- **Updated 5.9.23:** The meeting with the NPS and City Open Space indicated that they feel strongly that pre and post construction meetings need to be held to ensure that the environmental integrity of the Open Space is not compromised during construction. Notes may need to be added to the plat.

**(See additional comments on next page)*

These standards come from a draft Construction Mitigation Program for Development adjacent to MPOS. Items #1 and #2 will be findings of the plat approval and the NOD must accompany the site plan for building permit.

The Construction Team shall adhere to the following:

1. Standards of Construction
 - a. Protective measures shall be implemented during the actual construction phase of the project to ensure protection of MPOS property.
 - b. Notifications
 - i. Proposed construction report shall be provided to the MPOS Owner by e-mail or mail. (CoA Open Space Tricia Keefer and Petroglyph National Monument, Nancy Hendricks)
 - ii. Include the following information in the notification:
 1. The name of the project
 2. Dates of construction
 3. The contact information for the person responsible for mitigation
 4. Construction plan showing buffer and placement of **protection fencing**
 - c. Pre- construction meeting with MPOS representatives
 - i. Contractor and MPOS representatives will perform pre- and post-construction site meetings to discuss and agree to access and staging needs, work hours, proposed impacts and restoration plans, safety, noise and vibration impacts, and project timelines. Any access points, routes and access to and across the MPOS and buffer area shall be mutually agreed upon prior to construction-related activities.
 - d. The following actions are prohibited within MPOS and buffer zone:
 - i. Vehicular traffic or parking.
 - ii. Storage of construction materials, debris, or excavated material.
 - iii. Dumping of refuse or chemicals, or liquids.
 - iv. Puddling or continuous running water.
 - v. Diesel or gasoline equipment running adjacent to protection zone.
 - vi. Foot traffic.
 - vii. Erection of sheds or structures.
 - viii. Mixing or washing of concrete or any other cementitious products.
2. Final Clean Up and Inspection
 - a. Before final acceptance, the area along the MPOS and buffer zone shall be cleaned of all rubbish, excess materials, temporary structures, and equipment; and all parts of the work shall be left in an acceptable condition.

**(See additional comments on next page)*

- For the Final Plat, Hydrology, Transportation, and Water Authority staff must all sign Form S and ensure that any application submittals required in association with the Final Plat application are approved prior to their signatures on Form S. Form S must be signed by Hydrology, Transportation, and Water Authority staff prior to the acceptance of the Final Plat application and placement on a DHO agenda.
- The Final Plat is required to be submitted within one year of Preliminary Plat approval.
- A recorded IIA based on the Infrastructure List included with the Preliminary Plat submittal will be required with the Final Plat, and must be obtained and included with the Final Plat application submittal prior to the acceptance of the Final Plat and placement on a DHO agenda.

2. Standard Subdivision Comments and Items in Compliance:

5-2(C) Site Design to Avoid Sensitive Lands.

Updated 4/10/23:

- Applicant completed a Sensitive Lands Analysis and no sensitive land features were identified. Please note that site slopes are 8% or less and the property is no longer in the 100 year flood plain.
- The drainage note for compliance with Section 1013 is added to the infrastructure list.

Updated 6/12/23:

- ✓ The applicant has shown height measurements from finished grade and natural grade and established maximum building heights that do not exceed 15 feet.

IDO 3-6(E) The parcels are in the VPO-2 Height Restricted Sub Area. Identify the allowable structure height vis a vis grading plan. 'Building and/or structure height shall not exceed 15 feet, as measured from natural grade.'

~~*Show height measurements from finished grade and natural grade. *Clarify if standards are being met.~~

**(See additional comments on next page)*

3-6(E)(3) Building and Structure Height

The following standards apply in the Height Restrictions Sub-area shown in the map above.

3-6(E)(3)(a) Building and/or structure height shall not exceed 15 feet, as measured from natural grade. (See figures below.)

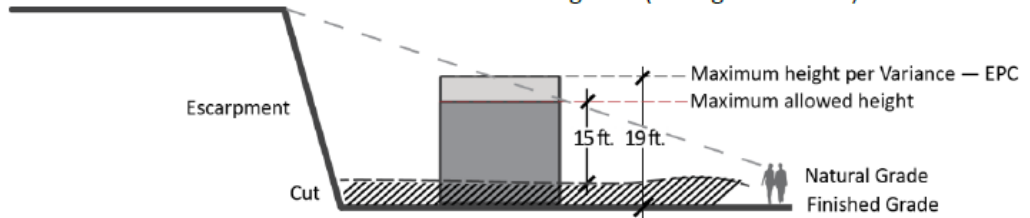

Updated 1/20/23:

- **Staff determined after much discussion that this applicant can proceed with the lot sizes presented on the Sketch Plat for the Preliminary Plat.** They do meet the contextual standards of the IDO. While an argument could be made that the new subdivision is its own block and R1-D lot sizes are required, there is also an argument for contextual standards applying and that is the advice that was given in prior sketch plats.

- **Applicant met the public notice requirements Section 6-1, table 6-1-1 for public notice requirements (6-6-L Subdivision of Land-Major).** The application was sent to the Superintendent of Petroglyph National Monument for comment and PNM agreed with the Open Space Division comments. (IDO 5-2-(J)(2)(c) 1 for comment by external agencies.)

3. Future Development Guidance

- Please reference the following development standards from the IDO. Subject to change pending formal submittal and/or proposed development types/uses.
 - 3-6(E) Northwest Mesa Escarpment – VPO-2 and *Height Restricted Sub-area.
Updated 4/10/23: Please note that building height shall not exceed 15 feet, as measured from the natural grade. See IDO 3-6(E) for details, and dealing with undulating terrain.

**(See additional comments on next page)*

See also restrictions on Colors, Reflectivity, and roof-mounted equipment. Use yellow ochers, browns, dull reds, and greens with Light reflective value ranging from 20 to 50 percent.

Fully screen roof-mounted HVAC from public street and escarpment.

- 4-2 Allowed Uses, table 4-2-1. ***Reference Use Specific Standards 4-3-B-1 Single Family Detached Dwelling.** Explain and demonstrate how all standards are being met.
- 5-1 Dimension Standards for R-1D and Area of Consistency. Calculations per Code Enforcement. 5-1-G Exceptions and Encroachments.
*Included setback measurements, and elevations with height measurements from finished grade and natural grade. *Clarify if standards are being met.
- **5-2-K** Property is abutting Major Public Open Space to the North and within MPOS Edges. Also abutting the Boca Negra Canyon Arroyo-Drainage Easement. Standards exist for each. Up to and including 5-2-K.
- **5-3 Access & Connectivity requirements.**
*5-3(C)(3) Driveways, Drive Aisles, and Access 5-3(C)(3)(a) Development shall comply with the driveway, drive aisle, and access standards in the DPM.
5-3(C)(3)(b) For all low-density residential development, driveways accessed from the front or street side of the property shall be at least 20 feet long, exclusive of the sidewalk or drive pad.
- 5-5 Parking & Loading requirements, Table 5-5-1.
Dwelling, single-family detached 1 space / DU up to 2 BR, 2 spaces / DU with 3 or more BR.
- 5-6 Landscaping, Buffering, and Screening standards and requirements.

Updated 4/10/23:

- 5-7 Walls/Fences. (E)(4) . *View fencing is required adjacent to Mayor Arroyos or Major Public Open Space. *Development requires separate permitting.

5-2(J)(2)(a). *Special wall provisions adjacent to MPOS.

**(See additional comments on next page)*

10. Locate and design all walls, fences, retaining walls, and combinations of those site features facing the Major Public Open Space in compliance with all applicable standards in Section 14-16-5-7(E)(4) (Walls Adjacent to Major Arroyos or Major Public Open Space).

- 5-11 Building and façade design requirements. 5-11-C for Low-Density Residential. *Demonstrate and explain how standards and requirements are being met.
- 7-1 Development, dwelling, and use definitions.
*Reference definitions for Low-Density Residential and Single Family Detached.



Disclaimer: The comments provided are based upon the information received from the applicant/agent. If new or revised information is submitted, additional comments may be provided by Planning.

FROM: Jolene Wolfley/Robert Webb/Leila Shadabi
Planning Department

DATE: 6/13/23

**(See additional comments on next page)*

DEVELOPMENT HEARING OFFICER

TRANSPORTATION DEVELOPMENT

DRB Project Number: 2020-003484
6341 Mojave

AGENDA ITEM NO: 4

SUBJECT: Preliminary Plat

ENGINEERING COMMENTS:

1. I see the Grading and Drainage plan shows Colton St. as a separate tract in order to keep the scour wall out of the ROW. Please ensure this is on the plat that we are approving. No objection.

. If new or revised information is submitted, additional comments may be provided by Transportation Development.

FROM: Ernest Armijo, P.E.
Transportation Development
505-924-3991 or earmijo@cabq.gov

DATE: June 14, 2023

ACTION:

APPROVED __; DENIED __; DEFERRED __; COMMENTS PROVIDED __; WITHDRAWN __

DELEGATED: _____ TO: (TRANS) (HYD) (WUA) (PRKS) (CE) (PLNG)

DEVELOPMENT HEARING OFFICER

Code Enforcement Comments

Disclaimer: Comments provided are based upon information received from applicant/agent. If new or revised information is submitted, additional comments may be provided by Planning staff.

Jeff Palmer-Code Enforcement Supervisor
Planning Department
jppalmer@cabq.gov

DATE: 6/14/2023

AGENDA ITEM NO: 4

DHO PROJECT NUMBER:

PR-2020-003484

SD-2023-00048 – PRELIMINARY PLAT

SKETCH PLAT 1-11-23 (DFT)

IDO - 2021

PROJECT NAME:

THE GROUP | RON HENSLEY agent for **NAFEESA PASHTOON** requests the aforementioned action(s) for all or a portion of: **LOTS 2 & 3 BLOCK 12 UNIT 3, VOLCANO CLIFFS SUBD** zoned **R1-D** located on **MOJAVE ST NW between UNSER BLVD and TESUQUE DR** containing approximately **4.25** acre(s). (E-10) [Deferred from 4/12/23, 4/26/23b, 5/10/23b, 5/24/23b]

PROPERTY OWNERS: PASHTOON NAFEESA

REQUEST: CREATE 19 LOTS FROM EXISTING TRACTS

COMMENTS: (Deferred prior to 5/24 Hearing to 6/14/23):

1. Property is located within 330 feet of a Major Public Open Space, and it appears to meet the buffer requirements for the proposed development as per IDO 5-2(J)(2)(a)(1). However, since the IDO indicates these buffers must be approved by the Open Space Superintendent, Code Enforcement would like to confirm Parks is in agreement with this determination. These required landscape buffer areas should be clearly marked and noted on the plat, as discussed in 5/10/23 Hearing.



Development Hearing Officer Planning - Case Comments

Meeting Date: 6/14/23 -- **DHO AGENDA ITEM #4**

Project Number: PR-2020-003484

Application Number: SD-2032-00048

Project Name: 6341 Mojave St NW

Request:

Preliminary Plat for 19 residential lots.

**These are preliminary Planning comments. Additional reviews and/or revised comments may be needed for any modifications and/or supplemental submittals.*

Items in red need to be addressed for the application to move forward.

COMMENTS:

1. Items that Need to be Completed or Corrected:

- **Updated 6.14.23:** Planning recommends a deferral of the application to June 28th pending an on-site meeting requested by the National Park Service (NPS) and City Open Space to determine future construction impacts resulting from this subdivision. Based on information gleaned in this meeting, the NPS will determine the federal approval process they sense is warranted. The applicant has provided a new plat that moves the scour wall 6 feet into the private parcel. This should allow scour wall construction that does not affect the National Monument. However, the issue of connecting the subdivision sewer line to the sewer line in the Boca Negra Arroyo has not been discussed and there is a lack of the agreement between the applicant and NPS/City Open Space. The NPS had asked for general construction documents to show details of trenching, etc. and the applicant did not provide that information. The NPS has requested an on-site meeting to give clarity to the construction needs and to determine the federal approval process that would be warranted.

As of 5.9.23: The applicant and staff of the NPS, City Open Space, City Planning and the City Engineer met circa 4.21.23. Both the NPS and COA Open Space clearly explained a private party would need to ask permission for a scour wall, a sewer connection, and/or an outflow from a drainage pond to the Boca Negra Arroyo drainage area. In the resubmittal, the applicant reworked the scour wall so that is on the private

**(See additional comments on next page)*

property side of the property line with the Arroyo. The applicant has not provided any documentation of having requested permission from the NPS or COA Open Space regarding the location of that scour wall, the connection to the sewer, and the outflow from the drainage pond to the Arroyo. Planning staff cannot recommend proceeding with the review and approval of this subdivision because of the IDO indicates that outside agencies have review rights and federal law must be followed. **See the following IDO provisions:**

1-8(D) If any regulation in this IDO conflicts with other applicable laws or regulations of the City, or conflicts with applicable State or federal law, the more restrictive provision shall prevail, unless the provisions of State or federal law, as interpreted by the courts, prevent that result.

6-4(J) REFERRALS TO COMMENTING AGENCIES

Following a determination that the application is complete, the Planning Director, ZEO, or any City staff designated to review applications in Table 6-1-1 shall refer applications for comment to the following departments or agencies, as noted below. Any comments received within 15 calendar days after such a referral shall be considered with the application materials in any further review and decision-making procedures.

6-4(J)(1) General

City departments or agencies or other governmental or quasi-governmental agencies whose services, properties, facilities, interests, or operations may be affected.

6-4(J)(6) Development within 660 feet of the Petroglyph National Monument

6-4(J)(6)(a) National Park Service.

6-4(J)(6)(b) Open Space Division of the City Parks and Recreation Department.

- **Updated 6.12.23** The Infrastructure list 'Notes/Drainage' needs to add the word "Standard" in front of "specification ."
- **Updated 5.9.23:** Landscaping is to follow Standard Specification 1013 and is noted on the Infrastructure List.
~~Tract A: Is there a landscaping Plan for Tract A? Any Landscape Plans must be sealed and signed by a Landscape Architect licensed in the State of New Mexico.~~
Updated 6.12.23 Change the maintenance note of Tract A (pond) to be the Homeowner's Association, not just 'owner'; city maintenance is not provided for Tract A.
- **Updated 5.9.23:** The meeting with the NPS and City Open Space indicated that they feel strongly that pre and post construction meetings need to be held to ensure that the environmental integrity of the Open Space is not compromised during construction. Notes may need to be added to the plat.

**(See additional comments on next page)*

These standards come from a draft Construction Mitigation Program for Development adjacent to MPOS. Items #1 and #2 will be findings of the plat approval and the NOD must accompany the site plan for building permit.

The Construction Team shall adhere to the following:

1. Standards of Construction
 - a. Protective measures shall be implemented during the actual construction phase of the project to ensure protection of MPOS property.
 - b. Notifications
 - i. Proposed construction report shall be provided to the MPOS Owner by e-mail or mail. (CoA Open Space Tricia Keefer and Petroglyph National Monument, Nancy Hendricks)
 - ii. Include the following information in the notification:
 1. The name of the project
 2. Dates of construction
 3. The contact information for the person responsible for mitigation
 4. Construction plan showing buffer and placement of **protection fencing**
 - c. Pre- construction meeting with MPOS representatives
 - i. Contractor and MPOS representatives will perform pre- and post-construction site meetings to discuss and agree to access and staging needs, work hours, proposed impacts and restoration plans, safety, noise and vibration impacts, and project timelines. Any access points, routes and access to and across the MPOS and buffer area shall be mutually agreed upon prior to construction-related activities.
 - d. The following actions are prohibited within MPOS and buffer zone:
 - i. Vehicular traffic or parking.
 - ii. Storage of construction materials, debris, or excavated material.
 - iii. Dumping of refuse or chemicals, or liquids.
 - iv. Puddling or continuous running water.
 - v. Diesel or gasoline equipment running adjacent to protection zone.
 - vi. Foot traffic.
 - vii. Erection of sheds or structures.
 - viii. Mixing or washing of concrete or any other cementitious products.
2. Final Clean Up and Inspection
 - a. Before final acceptance, the area along the MPOS and buffer zone shall be cleaned of all rubbish, excess materials, temporary structures, and equipment; and all parts of the work shall be left in an acceptable condition.

**(See additional comments on next page)*

- b. A post-construction meeting shall be held with MPOS and City representatives to verify the buffer zone, sensitive land feature, or MPOS has been adequately protected during construction.
 - c. Any damaged areas noted shall be restored per contractor expense.
- 5-2 (J)(2)(a) Lot 5 is abutting the Boca Negra arroyo. **Add a note to the plat indicating that the 45 feet buffer abutting the Petroglyph National Monument must have plant approval and location per the Open Space Superintendent.**

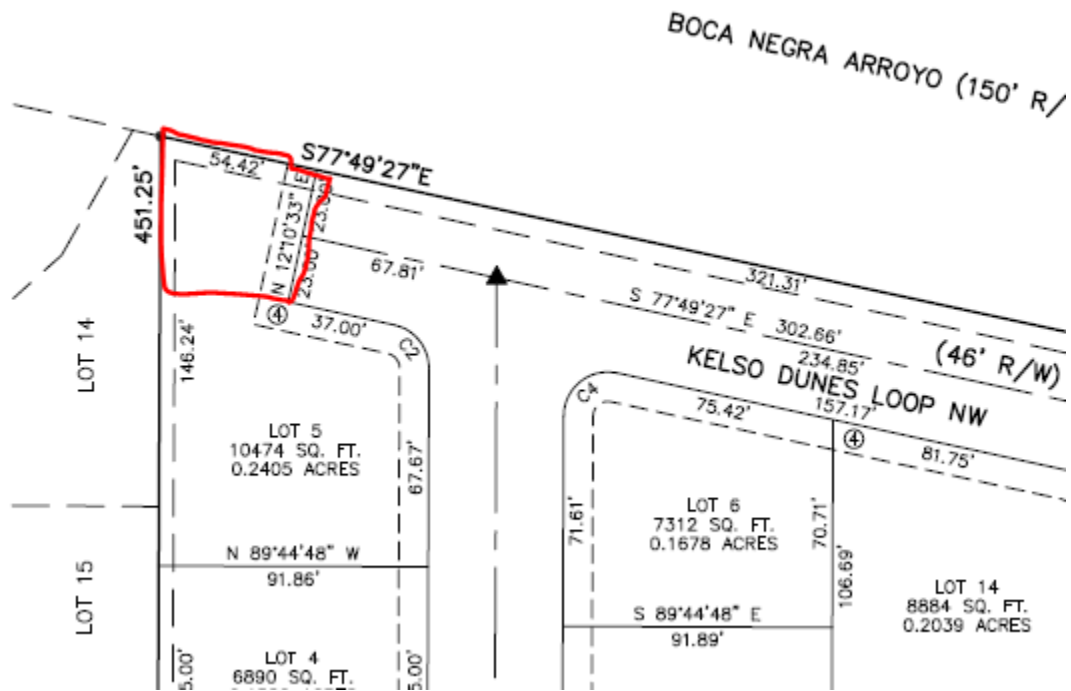

Future Required Final Plat:

- The project and application numbers need to be added to the Final Plat.
 - Utility and AMAFCA signatures will be required for the Final Plat, and must be obtained and included with the Final Plat application submittal prior to acceptance of the Final Plat and placement on a DHO agenda.
 - For the Final Plat, the DXF file must be approved by AGIS, and the approval email from AGIS must be submitted prior to final sign-off of the Final Plat from Planning should the Plat be approved by the DHO.

**(See additional comments on next page)*

- For the Final Plat, Hydrology, Transportation, and Water Authority staff must all sign Form S and ensure that any application submittals required in association with the Final Plat application are approved prior to their signatures on Form S. Form S must be signed by Hydrology, Transportation, and Water Authority staff prior to the acceptance of the Final Plat application and placement on a DHO agenda.
- The Final Plat is required to be submitted within one year of Preliminary Plat approval.
- A recorded IIA based on the Infrastructure List included with the Preliminary Plat submittal will be required with the Final Plat, and must be obtained and included with the Final Plat application submittal prior to the acceptance of the Final Plat and placement on a DHO agenda.

2. Standard Subdivision Comments and Items in Compliance:

5-2(C) Site Design to Avoid Sensitive Lands.

Updated 4/10/23:

- Applicant completed a Sensitive Lands Analysis and no sensitive land features were identified. Please note that site slopes are 8% or less and the property is no longer in the 100 year flood plain.
- The drainage note for compliance with Section 1013 is added to the infrastructure list.

Updated 6/12/23:

- ✓ The applicant has shown height measurements from finished grade and natural grade and established maximum building heights that do not exceed 15 feet.

IDO 3-6(E) The parcels are in the VPO-2 Height Restricted Sub Area. Identify the allowable structure height vis a vis grading plan. 'Building and/or structure height shall not exceed 15 feet, as measured from natural grade.'

~~*Show height measurements from finished grade and natural grade. *Clarify if standards are being met.~~

**(See additional comments on next page)*

3-6(E)(3) Building and Structure Height

The following standards apply in the Height Restrictions Sub-area shown in the map above.

3-6(E)(3)(a) Building and/or structure height shall not exceed 15 feet, as measured from natural grade. (See figures below.)

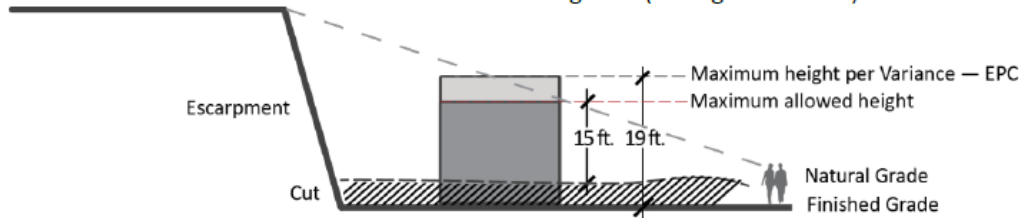

Updated 1/20/23:

- **Staff determined after much discussion that this applicant can proceed with the lot sizes presented on the Sketch Plat for the Preliminary Plat.** They do meet the contextual standards of the IDO. While an argument could be made that the new subdivision is its own block and R1-D lot sizes are required, there is also an argument for contextual standards applying and that is the advice that was given in prior sketch plats.

- **Applicant met the public notice requirements Section 6-1, table 6-1-1 for public notice requirements (6-6-L Subdivision of Land-Major).** The application was sent to the Superintendent of Petroglyph National Monument for comment and PNM agreed with the Open Space Division comments. (IDO 5-2-(J)(2)(c) 1 for comment by external agencies.)

3. Future Development Guidance

- Please reference the following development standards from the IDO. Subject to change pending formal submittal and/or proposed development types/uses.
 - 3-6(E) Northwest Mesa Escarpment – VPO-2 and *Height Restricted Sub-area.
Updated 4/10/23: Please note that building height shall not exceed 15 feet, as measured from the natural grade. See IDO 3-6(E) for details, and dealing with undulating terrain.

**(See additional comments on next page)*

See also restrictions on Colors, Reflectivity, and roof-mounted equipment. Use yellow ochers, browns, dull reds, and greens with Light reflective value ranging from 20 to 50 percent.

Fully screen roof-mounted HVAC from public street and escarpment.

- 4-2 Allowed Uses, table 4-2-1. ***Reference Use Specific Standards 4-3-B-1 Single Family Detached Dwelling.** Explain and demonstrate how all standards are being met.
- 5-1 Dimension Standards for R-1D and Area of Consistency. Calculations per Code Enforcement. 5-1-G Exceptions and Encroachments.
*Included setback measurements, and elevations with height measurements from finished grade and natural grade. *Clarify if standards are being met.
- **5-2-K** Property is abutting Major Public Open Space to the North and within MPOS Edges. Also abutting the Boca Negra Canyon Arroyo-Drainage Easement. Standards exist for each. Up to and including 5-2-K.
- **5-3 Access & Connectivity requirements.**
*5-3(C)(3) Driveways, Drive Aisles, and Access 5-3(C)(3)(a) Development shall comply with the driveway, drive aisle, and access standards in the DPM.
5-3(C)(3)(b) For all low-density residential development, driveways accessed from the front or street side of the property shall be at least 20 feet long, exclusive of the sidewalk or drive pad.
- 5-5 Parking & Loading requirements, Table 5-5-1.
Dwelling, single-family detached 1 space / DU up to 2 BR, 2 spaces / DU with 3 or more BR.
- 5-6 Landscaping, Buffering, and Screening standards and requirements.

Updated 4/10/23:

- 5-7 Walls/Fences. (E)(4) . *View fencing is required adjacent to Mayor Arroyos or Major Public Open Space. *Development requires separate permitting.

5-2(J)(2)(a). *Special wall provisions adjacent to MPOS.

**(See additional comments on next page)*

10. Locate and design all walls, fences, retaining walls, and combinations of those site features facing the Major Public Open Space in compliance with all applicable standards in Section 14-16-5-7(E)(4) (Walls Adjacent to Major Arroyos or Major Public Open Space).

- 5-11 Building and façade design requirements. 5-11-C for Low-Density Residential. *Demonstrate and explain how standards and requirements are being met.
- 7-1 Development, dwelling, and use definitions. *Reference definitions for Low-Density Residential and Single Family Detached.



Disclaimer: The comments provided are based upon the information received from the applicant/agent. If new or revised information is submitted, additional comments may be provided by Planning.

FROM: Jolene Wolfley/Robert Webb/Leila Shadabi
Planning Department

DATE: 6/13/23

**(See additional comments on next page)*

From: [Rodenbeck, Jay B.](#)
To: [Gomez, Angela J.](#)
Cc: [Wolfley, Jolene](#)
Subject: FW: [EXTERNAL] RE: PR #3484 Mojave Subdivision - National Park Service Comments
Date: Monday, June 12, 2023 12:47:17 PM
Attachments: [image001.png](#)
[SANITARY SEWER MANHOLE DWG 2102.pdf](#)
[section 900 sewer.pdf](#)

Hi Angela,

Could you please file the attached message into the project folder for PR-2020-003484 in DMDview. It's an important email .

Thanks,

Jay

From: Hendricks, Nancy E <Nancy_Hendricks@nps.gov>
Sent: Monday, June 12, 2023 12:38 PM
To: ron@thegroup.cc; Thacker, Charles M <Charles_Thacker@nps.gov>
Cc: Keffer, Tricia M. <tkeffer@cabq.gov>; Langan-McRoberts, Colleen <cmcroberts@cabq.gov>; Rodenbeck, Jay B. <jrodenbeck@cabq.gov>; Biazar, Shahab <sbiazar@cabq.gov>; Wolfley, Jolene <jwolfley@cabq.gov>; Walter, Chanteil G <Chanteil_Walter@nps.gov>
Subject: Re: [EXTERNAL] RE: PR #3484 Mojave Subdivision - National Park Service Comments

[EXTERNAL] Forward to phishing@cabq.gov and delete if an email causes any concern.

Hi Ron and everyone,

I believe a good next step would be to meet on site with Ron, the NPS, and the City to better understand what this connection would entail. That way the NPS and City can assess the potential effects and compliance and permitting pathway more accurately. We don't have enough information about the actual work involved at this time.

I'm asking Chanteil Walter from Petroglyph to work with Ron to set up a meeting on-site including any interested City staff.

Mahalo,

Nancy

Nancy Hendricks, *Acting Superintendent*
Kaloko-Honokōhau National Historical Park (KAHO)

Pu'uhonua o Hōnaunau National Historical Park (PUHO)
73-4786 Kanalani St. #14
Kailua-Kona 96740-2600

(808) 329-6881 x 1201 (KAHO)
(808) 328-2326 x 1101 (PUHO)

From: ron@thegroup.cc <ron@thegroup.cc>
Sent: Friday, May 19, 2023 6:53 AM
To: Hendricks, Nancy E <Nancy_Hendricks@nps.gov>
Cc: tkeffer <tkeffer@cabq.gov>; 'Langan-McRoberts, Colleen' <cmcroberts@cabq.gov>; jrodenbeck@cabq.gov <jrodenbeck@cabq.gov>; sbiazar@cabq.gov <sbiazar@cabq.gov>; 'Jolene WOLFLEY' <jwolfley@cabq.gov>; Walter, Chanteil G <Chanteil_Walter@nps.gov>
Subject: [EXTERNAL] RE: PR #3484 Mojave Subdivision - National Park Service Comments

This email has been received from outside of DOI - Use caution before clicking on links, opening attachments, or responding.

Ms. Hendricks,

The existing sanitary sewer line is constructed within a Public Easement and is not within the physical arroyo. The 10 feet of sewer line and manhole will be constructed under the Standard Specifications The City Standard Drawings and Specifications of the connection are available and are attached. This "Public Easement" existed prior to the creation of the monument. Your opinion revokes the public interest in the easement without regard for Act. The 2023 Cooperative Management Agreement was intended for the Visitor Center and access and can't amend Federal Legislation.

PETR PL 101-313:

SEC. 107. EXISTING TRANSMISSION OR DISTRIBUTION FACILITIES.

Nothing in this title shall be construed as authorizing or requiring revocation of any interest or easement for existing transmission or distribution facilities or prohibiting the operation and maintenance of such facilities within or adjacent to the monument boundary.

I believe you have completely disregarded the establishing legislation, and you have offered several legal opinions on property rights. Are these opinions being provided as sworn statements?

You opinions and the process you have proposed is excessively burdensome and presents significant hardship to the owner. The owners rights in property and public easement access are being revoked.

The sewer connection proposed presents no impact to the Monument.

Sincerely,

Ron E. Hensley P.E.

505-410-1622



ron@thegroup.cc

From: Hendricks, Nancy E <Nancy_Hendricks@nps.gov>

Sent: Friday, May 19, 2023 9:47 AM

To: ron@thegroup.cc

Cc: tkeffer <tkeffer@cabq.gov>; Langan-McRoberts, Colleen <cmcroberts@cabq.gov>; jrodenbeck@cabq.gov; sbiazar@cabq.gov; Jolene WOLFLEY <jwolfley@cabq.gov>; Walter, Chanteil G <Chanteil_Walter@nps.gov>

Subject: PR #3484 Mojave Subdivision - National Park Service Comments

United States Department of the Interior

NATIONAL PARK SERVICE
Petroglyph National Monument
6001 Unser Blvd NW
Albuquerque, New Mexico 87120

IN REPLY REFER TO:
I.A.1.

May 19, 2023

Mr. Ron Hensley
The Hensley Engineering Group
Email: ron@thegroup.cc

Re: 2020-003484 Mojave Ridge Subdivision Supplemental Submittal

Mr. Hensley,

I am writing on behalf of the National Park Service (NPS) concerning the proposed sewer line at the Mojave Ridge Subdivision. It is our understanding that you are proposing to connect the housing development sewer line to an existing sewer line within Petroglyph National Monument (Monument). The connecting sewer line would be constructed through the Boca Negra Canyon Arroyo and would be connected to an existing sewer line located in a City of Albuquerque Municipal Development Easement. The Boca Negra Canyon Arroyo itself appears to be outside the City easement but is within the Monument boundary and is city-owned Open Space land.

At the May 10, 2023, Development Hearing Officer meeting, the NPS and City of Albuquerque Open Space Division requested additional information from you related to this proposal, including the details of the intended construction within the arroyo. In an email dated May 15, 2023, you provided the grading plan for the subdivision. This plan did not include any detailed information on the proposed sewer line connection.

We request more information on the proposed sewer line to allow us to evaluate this project in accordance with federal law and policy. This project would be considered a new right-of-way (ROW) within Petroglyph National Monument and as such, it would require the submittal of a ROW permit application. Since it is located on Major Public Open Space, per the 2023 Cooperative Management Agreement (CMA) between the NPS and the City of Albuquerque (Article II (3) h), you would be required to obtain a permit with the City of Albuquerque for this work per CMA Article II (3) h.: *Right-of-Way (ROW) permits for existing ROWs and easements will be authorized by the appropriate land management agency depending on the land ownership status. New ROW permits and/or projects related to the construction of new utilities, water/wastewater, telecommunications facilities, drainage, or similar projects will be reviewed per Article I. (3).* This permit is discretionary, is revocable, and does not convey or imply any interest in the land. You would work with the City of Albuquerque to obtain this permit. Please follow up

with the City Planning Department to identify the permitting requirements.

In addition, because this land falls within the boundary of Petroglyph National Monument, you would be required to obtain a permit from the National Park Service. The first step in the permitting process is to submit a SF-299 Application Form. Once we receive all the required information on this project, the NPS would analyze the proposal in accordance with federal laws and policies.

In addition to the SF-299 application form, please submit detailed drawings of the proposed sewer line, construction documents providing information on the depth, width, and length of the trench needed for the placement of the pipe, the dimensions of the pipe, what type of equipment would be used, duration and timing of the work, how much of the line would actually be within the Monument boundary, access and staging areas for construction, and how the line would be protected from spills/breakage since it would be located within the arroyo.

Locating a sewer line in an arroyo is a concern to us. We urge you to consider other options outside the Monument boundary. Have you considered connecting the development sewer line into the main line that is located within the Mojave Street NW corridor? What is your justification for connecting to the sewer line through the arroyo, and not connecting to the existing sewer lines located within the adjacent city street?

Per the 1990 Establishment Legislation for Petroglyph National Monument (Public Law 101-313), the Monument is administered, managed, and protected in accordance with the National Park Service Organic Act in such a manner as to preserve, for the benefit and enjoyment of present and future generations, its cultural and natural resources. Our primary mandate is to preserve the cultural and natural resources within the Monument, thus all proposals for construction within the Monument must be assessed through this lens.

The Establishment Legislation further states that federal laws generally applicable to units of the National Park System, including but not limited to, the National Environmental Policy Act, shall apply to the monument. The CMA affirmed this process.

Article I (3): Proposed projects on federally and City-owned lands within the Monument boundaries will be assessed following NPS guidelines for compliance with applicable federal laws, including, but not limited to, the National Environmental Policy Act, the National Historic Preservation Act; and other applicable federal, state, and local laws and regulations. Consultation and collaboration with traditionally associated Pueblos and Tribes and the State Historic Preservation Office will be an on-going standard practice.

All construction inside the Monument is subject to 36 C.F.R. 5.7, which states:

"Constructing or attempting to construct a building, or other structure, boat dock, road, trail, path, or other way, telephone line, telegraph line, power line, or any other private or public utility, upon across, over, through, or under any park areas, except in accordance with the provisions of a valid permit, contract, or other written agreement with the United States, is prohibited."

For the NPS to review the proposed work within the Monument's boundary, on lands owned by the City of Albuquerque Open Space Division, you must provide a written request containing information that would allow the NPS to analyze the proposal per federal law. We would also initiate Tribal Consultation for the proposed project pursuant to the National Environmental Policy Act and Section 106 of the National Historic Preservation Act (36 CFR 800.2). The environmental and cultural review processes may take several months and require additional steps related to proposed construction in an arroyo.

Also, 54 U.S.C. § 1031042 authorizes the NPS to recover and retain all costs of providing necessary services associated with special use permits including costs associated with environmental and cultural reviews, as well as all agency costs incurred in monitoring or associated with managing the permitted

activity if the request is approved.

Until we work through these processes, we cannot endorse this proposed work within Petroglyph National Monument.

If you would like to discuss further or need additional information, please contact me at Nancy_hendricks@nps.gov and we can set up a meeting with our Regional staff who would assist us in this process.

Sincerely,

Nancy Hendricks
Superintendent

[Standard Form 299 - Application for Transportation, Utility Systems, Telecommunications and Facilities on Federal Lands and Property \(nps.gov\)](#)

Cc:
City of Albuquerque Open Space
City of Albuquerque Planning Department
City of Albuquerque Development Hearing Officer

From: [Wolfley, Jolene](#)
To: [Gomez, Angela J.](#)
Cc: [Chen, Tiequan](#)
Subject: PR #3484 FW: DOI-NPS-2023-004394 Request
Date: Friday, June 9, 2023 7:42:01 AM
Attachments: [image001.png](#)
[NPS Acknowledgment Letter.pdf](#)

Please add to the file for this case.

From: ron@thegroup.cc <ron@thegroup.cc>
Sent: Tuesday, May 16, 2023 5:21 PM
To: Wolfley, Jolene <jwolfley@cabq.gov>
Cc: Biazar, Shahab <sbiazar@cabq.gov>
Subject: FW: DOI-NPS-2023-004394 Request

[EXTERNAL] Forward to phishing@cabq.gov and delete if an email causes any concern.

I expect the Petroglyph National Monument Roadway/Utility Corridors to provide further direction on construction in the utility easement and drainage corridor, but the City has not been able to provide the document as required. Therefore, I wanted to forward my FOIA request for the Petroglyph National Monument Roadway/Utility Corridors to the Dept. of Interior. I will share the document when it is received.

Ron E. Hensley P.E.
505-410-1622



ron@thegroup.cc

From: npsfoia@email.doi.gov <npsfoia@email.doi.gov>
Sent: Tuesday, May 16, 2023 6:31 AM
To: ron@thegroup.cc
Cc: alison_yamato@nps.gov
Subject: DOI-NPS-2023-004394 Request

05/16/2023

Mr. Hensley,

On 005/05/2023 the **National Park Service (NPS)** received your **Freedom of Information Act (FOIA)** request, dated 05/05/2023, and assigned it control number **DOI -NPS-2023-004394**. Please cite this number in any future communications with our office regarding your request.

We have classified you as an “other-use” requester. As such, we may charge you for some of

our search and duplication costs, but we will not charge you for our review costs; you are also entitled to up to 2 hours of search time and 100 pages of photocopies (or an equivalent volume) for free. See [43 C.F.R. § 2.39](#). If, after taking into consideration your fee category entitlements, our processing costs are less than \$50.00, we will not bill you because the cost of collection would be greater than the fee collected. See [43 C.F.R. § 2.37\(g\)](#).

"Do what you can, with what you have, where you are."

-Theodore Roosevelt

Alison Yamato

Government Information Specialist

NPS FOIA Officer - Intermountain Region

Department of Interior Regions 6, 7 & 8

12795 W Alameda Pkwy

Lakewood, CO 80228

05/16/2023

Mr. Hensley,

On 005/05/2023 the **National Park Service (NPS)** received your **Freedom of Information Act (FOIA)** request, dated 05/05/2023, and assigned it control number **DOI -NPS-2023-004394**. Please cite this number in any future communications with our office regarding your request.

We have classified you as an “other-use” requester. As such, we may charge you for some of our search and duplication costs, but we will not charge you for our review costs; you are also entitled to up to 2 hours of search time and 100 pages of photocopies (or an equivalent volume) for free. See [43 C.F.R. §2.39](#). If, after taking into consideration your fee category entitlements, our processing costs are less than \$50.00, we will not bill you because the cost of collection would be greater than the fee collected. See [43 C.F.R. §2.37\(g\)](#).

“Do what you can, with what you have, where you are.”

-Theodore Roosevelt

Alison Yamato

Government Information Specialist

NPS FOIA Officer - Intermountain Region

Department of Interior Regions 6, 7 & 8

12795 W Alameda Pkwy

Lakewood, CO 80228

SECTION 900

SANITARY AND STORM SEWER FACILITIES

900.1 GENERAL: This section pertains to the collection and conveyance facilities for sewage and storm runoff in underground piping systems.

900.2 CONTENTS

Section No.	Title
901	Sanitary Sewer Collector and Interceptor Facilities
905	Sanitary Sewer Service Lines
910	Storm Sewer Pipe Installations
912	Polypropylene Pipe for Storm Sewers
915	Storm Sewer Drainage Appurtenances
920	Sanitary Sewer Manholes
921	Storm Manholes
925	Vacuum Sewer Collector, Interceptor and Force Main Facilities

SECTION 901

SANITARY SEWER COLLECTOR AND INTERCEPTOR FACILITIES

901.1 GENERAL:

The construction items, specified in this section, are common to sanitary sewer collector and interceptor facilities.

901.2 REFERENCES

901.2.1 ASTM

D 2321 Standard Practice for Underground Installation of Thermoplastic Pipe for Sewers and Other Gravity-Flow Applications

D 3034 Standard Specification for Type PSM Poly (Vinyl Chloride) (PVC) Sewer Pipe and Fittings

F 679 Standard Specification for Poly (Vinyl Chloride) (PVC) Large-Diameter Plastic Gravity Sewer Pipe and Fittings

F 794 Standard Specification for Poly (Vinyl Chloride) (PVC) Profile Gravity Sewer Pipe and Fittings Based on Controlled Inside Diameter

901.2.2 (intentionally left blank)

901.2.3 This publication per SECTIONS:

- 121 Plastic Pipe
- 131 Fiberglass Pipe
- 701 Trenching, Excavation and Backfill

901.3 MATERIALS

901.3.1 PIPE:

Sewer line pipe and fittings shall be as specified in other sections, as follows:

- Section 121 Plastic Pipe
- Section 131 Fiberglass Pipe

901.4 CERTIFICATION:

The OWNER / ENGINEER will be supplied with a certification on each item or type of material required in the sewer line, as to that item meeting the specifications and / or the reference specifications before that item is installed.

901.5 INSTALLATION

901.5.1 GENERAL

901.5.1.1 Pipe and appurtenances shall be new and unused. The type of pipe to be installed shall be as approved by these specifications or unless otherwise shown on the project construction drawings. Pipe and appurtenances shall be handled in such a manner as to ensure delivery to the trench in sound, undamaged condition. Particular care shall be taken to prevent damage to any pipe coating.

901.5.1.2 The interior of the pipe shall be thoroughly cleaned of foreign material before being lowered into the trench and shall be kept clean during construction operations. When work is not in progress, the open ends of pipe shall be securely closed so that no foreign materials will enter the pipe. Any section of pipe found to be defective before or after installation, shall be replaced with sound pipe, or repaired in a manner satisfactory to the ENGINEER, without additional expense to the OWNER.

901.5.1.3 The CONTRACTOR shall install a plug in the new sewer at any point of connection to an existing system. The CONTRACTOR shall not flush or otherwise discharge any flow into an existing system unless approved in writing by the ENGINEER and Water Authority.

901.5.1.3.1 The plug shall remain in place until the ENGINEER or Water Authority authorizes its removal in writing. Under all circumstances, the CONTRACTOR shall be required to remove all plugs prior to acceptance of the work.

901.5.1.3.2 The CONTRACTOR shall certify in writing the completion of the plug removal task. The certification shall include the locations of removed plugs and corresponding date of removal. The Water Authority assumes no liability for damages caused by plugs inadvertently left in the line by the Contractor.

901.5.1.4 Pipe shall be laid to line and grade as shown on the project construction plans. The bedding of the trench shall be graded and prepared to provide a firm and uniform bearing throughout the entire length of the pipe barrel. Suitable excavation shall be made to receive the bell of the pipe and the joint shall not bear upon the bottom of the trench. All adjustment to the line and grade shall be made by scraping away or filling in with pipe zone material under the body of the pipe, and not by wedging or blocking. When connections are to be made to any existing manhole, pipe, or other improvement, the actual elevation or position of which cannot be determined without excavation, the CONTRACTOR shall excavate for and expose the existing improvement before laying the connecting pipe or conduit. When existing underground improvements may reasonably be expected to conflict with the line or grade established for the new sewer line, the ENGINEER shall request the CONTRACTOR to excavate as necessary to expose and locate such potentially conflicting underground improvements prior to laying the new pipe. Any adjustment in line or grade which may be necessary to accomplish the intent of the construction plans will be made, and the CONTRACTOR will be paid for any additional work resulting from such change in line or grade in the manner provided for in the General Conditions.

901.5.1.5 Connections to existing sanitary sewer manholes shall be made by core drilling through the manhole wall. The CONTRACTOR shall take care to avoid unnecessary damage to the existing manhole.

SECTION 901

SANITARY SEWER COLLECTOR AND INTERCEPTOR FACILITIES

901.5.1.6 Pipe shall be laid upgrade in a continuous operation from structure to structure, with the bell end of the pipe upgrade unless otherwise permitted by the ENGINEER.

901.5.1.7 Sanitary sewer mains shall not be constructed under walkways, sidewalks, curbs and gutters, drive pads, or similar concrete structures by tunneling underneath them. The CONTRACTOR will remove the section of the concrete structure to the nearest full expansion joint or edge.

901.5.1.8 Prior to completely backfilling the sewer excavation, install a green metalized detectable warning tape 12" to 18" below finished grade. The tape shall be detectable with a standard metal pipe locator. The tape shall be a minimum of 2 inches wide and inscribed at 10-foot intervals with the words, "CAUTION BURIED SEWER LINE BELOW". The tape shall be constructed of material that is impervious to alkalis, acids, chemical reagents, and solvents found in the soils.

901.5.1.9 TRACE WIRE

901.5.1.9.1 GENERAL

901.5.1.9.1.1 Trace wire shall be installed on all public sanitary sewer interceptor, collector, and any other lines considered public infrastructure that will be owned and maintained by the Water Authority.

901.5.1.9.1.2 Trace wire shall be installed in such a manner as to be able to properly trace all pipelines as applicable, without loss or deterioration of the signal.

901.5.1.9.2 MATERIALS: The CONTRACTOR shall submit the manufacturer's data on materials to be furnished that indicate compliance with the specifications regarding materials used. Only products or materials listed on the Water Authority Approved Product List shall be used.

901.5.1.9.2.1 For open trench installation, #12 AWG high strength copper clad steel wire with a minimum 450 pound break load and minimum 30 mil HDPE insulation thickness shall be used.

901.5.1.9.2.2 For directional drilling/boaring installation, #12 AWG high strength copper clad steel wire with a minimum 1,150 pound break load minimum 45 mil HDPE insulation thickness shall be used.

901.5.1.9.2.3 For pipe bursting installation, high strength 7x7 stranded copper clad steel wire with 4,700 pound break load and minimum 50 mil HDPE insulation thickness shall be used.

901.5.1.9.3 CONNECTORS:

901.5.1.9.3.1 Tee Connections: Single 3-way locking waterproof connector for 12 AWG. Connectors shall be approved by the manufacturer for direct burial.

901.5.1.9.3.2 Cross Connectors: Two 3-way locking waterproof connectors for 12 AWG with a short jumper wire. Connectors shall be approved by the manufacturer for direct burial.

901.5.1.9.3.3 Necessary Splice Connections: Single 3-way direct bury lug locking connector rated up to 50 volts filled with dielectric silicone sealant to seal out moisture and corrosion and prevent uninsulated wire exposure. Connectors shall be approved by the manufacturer for direct burial. Splices shall only be used on the main line at the end of a trace wire spool or when a Tee Connection cannot be used. The CONTRACTOR shall not cut the main line trace wire.

901.5.1.9.3.4 Non-locking friction fit, twist on or taped connectors are prohibited.

901.5.1.9.4 TEST STATIONS

901.5.1.9.4.1 All trace wire test stations shall be made of corrosion-resistant materials and shall be equipped with two terminals, a roadway-rated flange to prevent the test station from sinking, and a locking cast iron cap with an encapsulated magnet for ease of locating the test station. The test station shall be specifically manufactured for trace wire access/testing.

901.5.1.9.4.2 All grade level/in-ground test stations shall be appropriately identified with "Test Station" and with "Sewer" cast into the cap and color coded Green.

901.5.1.9.4.3 All trace wire test stations must include a manually interruptible conducting/connection link (terminal jumper) between the terminal for the trace wire connection and terminal for the grounding anode wire connection.

901.5.1.9.5 GROUNDING ANODE: All grounding anodes shall be made of magnesium, with a pointed end to enable direct driving into the ground, specifically manufactured for this purpose. The anode shall come factory equipped with an HDPE cap and 20 feet of factory installed #12 AWG copper clad steel wire with 30 mil HDPE coating rated for direct burial at 30 volts with 21% conductivity. The wire shall have a minimum 450 pound break load.

901.5.1.9.6 COLOR CODING: The insulation of the trace wire and the color of the test station caps shall be Green.

901.5.1.9.7 INSTALLATION

901.5.1.9.7.1 TRACE WIRE INSTALLATION

901.5.1.9.7.1.1 The trace wire shall be installed in the same trench and inside bored holes and casing with pipe during pipe installation.

SECTION 901

SANITARY SEWER COLLECTOR AND INTERCEPTOR FACILITIES

901.5.1.9.7.1.2 The trace wire shall be securely bonded together at all wire joints with a locking waterproof connector that complies with this specification to provide electrical continuity.

901.5.1.9.7.1.3 Trace wire connectors shall be installed in a manner that prevents any uninsulated wire exposure.

901.5.1.9.7.1.4 Except for spliced-in repair or replacement connections, trace wire shall be continuous and without splices between each trace wire access point. For required splices, use splice connectors per this specification. Spliced wires must be knotted prior to being inserted in the connector to prevent separation from the connector in case the trace wires are stretched during backfilling operations.

901.5.1.9.7.1.5 Trace wire systems must be installed as a single continuous wire. No looping or coiling of wire is allowed.

901.5.1.9.7.1.6 No breaks or cuts in the trace wire or trace wire insulation shall be permitted.

901.5.1.9.7.1.7 Trace wire installation shall be performed in such a manner that allows proper access for connection of line tracing equipment, proper locating of wire without loss or deterioration of low frequency (512 Hz) signal for distances in excess of 1,500 linear feet, and without distortion of signal caused by multiple wires being installed in close proximity to one another.

901.5.1.9.7.1.8 Any damage occurring during installation of the trace wire must be immediately repaired by removing the damaged wire, and installing a new section of wire with connectors that comply with this specification. Taping and/or spray coating to repair trace wire or trace wire insulation shall not be allowed.

901.5.1.9.7.1.9 Trace wire shall be laid flat on top of the pipe and securely affixed in 6-foot intervals with tape or plastic ties to prevent shifting or damage during backfilling and excavation operations.

901.5.1.9.7.1.10 In occurrences where an existing trace wire is encountered on an existing utility that is being extended or tied into, the new trace wire and existing trace wire shall be connected using splice connectors that comply with this specification.

901.5.1.9.7.1.11 Not used.

901.5.1.9.7.1.12 At service saddles, the trace wire shall not be placed between the saddle and the main.

901.5.1.9.7.1.13 Lay the mainline trace wire continuously by-passing around the outside of manholes, vaults and other structures on the north or east side.

901.5.1.9.7.1.14 For main line intersections, the main line

trace wire shall not be cut.

901.5.1.9.7.1.15 All main line trace wires must be interconnected at intersections, at main line tees and main line crosses. At tees, the three wires shall be joined using a single 3-way locking connector. At crosses, the four wires shall be joined using two 3-way connectors with a short jumper wire between them.

901.5.1.9.7.1.16 All trace wire termination points shall be terminated with a grounding anode.

901.5.1.9.7.1.17 For repairs and rehabilitations, trace wire shall be installed on the new line per this specification. The ends of rehabilitated/replaced pipeline segments shall be connected if existing trace wire exists or shall be terminated with a grounding anode.

901.5.1.9.7.1.18 If repairs are made to a line with a trace wire, Contractor must ensure trace wire is connected with an approved splice connector and test the trace to the next existing test station.

901.5.1.9.8 TEST STATIONS

901.5.1.9.8.1 Test stations shall be installed at the following locations as outlined in the Standard Detail Drawings:

901.5.1.9.8.1.1 At sanitary sewer manholes and sanitary sewer wet wells;

901.5.1.9.8.1.2 At sanitary sewer force main valves;

901.5.1.9.8.1.3 At sanitary sewer vacuum valves;

901.5.1.9.8.2 A minimum of 6 inches of excess/slack wire is required in all trace wire test stations after meeting final elevation. Group and zip-tie excess wire. Do not coil.

901.5.1.9.8.3 Test stations shall be spaced approximately every 1,000 feet and shall not be spaced greater than 1,500 feet apart. Test stations do not need to be installed at each location identified above provided that the spacing between test stations does not exceed 1,500 feet.

901.5.1.9.9 GROUNDING

901.5.1.9.9.1 Trace wire must be properly grounded at all termination points.

901.5.1.9.9.2 Grounding of trace wire shall be achieved by use of a drive-in magnesium grounding anode rod buried at the same depth as the trace wire.

901.5.1.9.9.3 Where the grounding anode wire will be connected to a trace wire test station, a minimum of 6 inches of excess/slack wire is required after meeting final elevation.

SECTION 901

SANITARY SEWER COLLECTOR AND INTERCEPTOR FACILITIES

901.5.1.9.9.4 When grounding the trace wire in areas where the trace wire is continuous and neither the mainline trace wire nor the grounding anode wire will be terminated at/above grade, install grounding anode directly beneath and at the same depth as the trace wire. Do not coil excess wire from grounding anode. The grounding anode wire shall be trimmed to an appropriate length before connecting to trace wire with a splice connector. Install with spliced connection to main trace wire at beginning or endpoints of pipe runs, only when there is no test station box present. If test station is nearby/available, red trace wire from magnesium grounding anode shall be continuous to the terminal in the test station (no other connections or splices).

901.5.1.9.10 TESTING REQUIREMENTS

901.5.1.9.10.1 Contractor shall provide equipment for trace test and shall perform a trace test on all trace wire in the presence of the ENGINEER and WATER AUTHORITY INSPECTOR. If the trace wire is found to be not continuous upon testing, the CONTRACTOR shall repair or replace the failed segment of the wire, and shall be responsible for the cost of any trenching, backfill, repaving and other improvements necessary to complete the trace wire repair. Contractor is encouraged to test trace wire prior to backfill so any issues can be addressed prior to backfill. Passing test results shall be provided for all pipe segments within the Engineer of Record’s as-built data and plan set. To pass the continuity test, the following conditions must be met:

901.5.1.9.10.1.1 Trace test shall be performed by using a metallic locator with audible tone and numeric values for certification of the facility locations and shall be identifiable between access points.

901.5.1.9.10.1.2 The wire shall be accessible at all access points and be identifiable between access points.

901.5.2 PLASTIC PIPE INSTALLATION:

901.5.2.1 Plastic sewer pipe shall be connected and placed in the trench in accordance with the manufacturer’s recommendations. Where a conflict arises with this Specification, this Specification shall control. Trenching, embedment, and backfill shall be as specified in Section 701.

901.5.2.2 The reference mark (a distinct circumferential line) is placed on the pipe’s spigot end by the manufacturer to indicate the correct depth of spigot penetration into the pipe gasket joint. If the pipe is seated too deep or too shallow, the pipe may buckle or separate due to thermal expansion / contraction. Spigot penetration shall be within ¼-inch of the manufacturer’s recommended mark.

901.5.2.3 For plastic or fiberglass pipe connection to manholes the CONTRACTOR shall install an appropriately sized and approved press seal gasket. The gasket shall be installed per manufacturer’s directions. No direct payment

shall be made for this item. This cost shall be incidental to the pipe’s bid item.

901.5.2.4 Not less than thirty (30) days after the installation and backfilling of plastic or fiberglass sewers, including any service connections, the CONTRACTOR shall, in the presence of the ENGINEER, test deflection of the pipe with a mandrel. The mandrel shall be hand pulled. All pipe with deflections in excess of five (5) percent of the base internal diameter, as determined by ASTM D 3034, ASTM F 679, or ASTM F 794 shall be excavated, re-rounded, backfilled and retested after an additional period of at least thirty (30) days. Mandrels shall have nine (9) ribs and be only hand pulled through the test section. The CONTRACTOR shall furnish the mandrels. The length of the minimum radius portion of the mandrel shall not be less than the one-third (1/3) of the nominal diameter of the pipe tested. The minimum mandrel diameter shall be no less than ninety (90) percent of the pipe inside diameter. The pipe shall be flushed and cleaned by the CONTRACTOR prior to testing. No flow will be permitted in the pipe while testing for deflections.

901.5.2.5 All expense for trenching, backfill, compaction, paving, and related work that is required because of failure to meet deflection test requirements shall be borne by the CONTRACTOR.

901.5.2.6 Acceptance of plastic pipe or fiberglass pipe sewers will be made only after these deflection test requirements have been met.

901.5.2.7 Minimum Diameters of Mandrels

901.5.2.7.1

<u>Nominal Pipe Size Diameter</u>	<u>Min. Mandrel</u>
8 in.	7.2 in.
10 in.	9.0 in.
12 in.	10.8 in.
15 in.	13.5 in.
18 in.	16.2 in.
21 in.	18.9 in.
24 in.	21.6 in.
27 in.	24.3 in.

901.6 JOINTS FOR PIPE

901.6.1 (deleted section)

901.6.2 (deleted section)

SECTION 901

SANITARY SEWER COLLECTOR AND INTERCEPTOR FACILITIES

901.6.3 JOINT FOR PLASTIC SEWER PIPE (PVC):

901.6.3.1 Refer to ASTM D 2321 and ASTM F 794 for pipe laying and joining of pipe guidelines.

901.6.3.2 Prior to the laying of pipe, each pipe component shall be inspected for damage and cleaned. Damaged components shall be rejected or repaired.

901.6.3.3 All joints will be assembled in accordance with manufacturer's published recommendations. If a lubricant is required to facilitate assembly, it shall have no detrimental effect on the gasket or on the pipe when subjected to prolonged exposure. Proper jointing may be verified by rotation of the spigot by hand or with a strap wrench. If unusual joining resistance is encountered or if the insertion mark does not reach the flush position, disassemble the joint components and repeat the assembly steps. Note that fitting bells may permit less insertion depth than pipe bells. When mechanical equipment is used to assemble joints, care should be taken to prevent over-insertion.

901.6.4 JOINT FOR FIBERGLASS PIPE

901.6.4.1 All joints shall be as specified in Section 131 FIBERGLASS PIPE

901.7 TESTING FOR LEAKAGE

901.7.1 GENERAL:

901.7.1.1 Unless otherwise shown on the construction drawings or specifically deleted by the ENGINEER, in writing, all sanitary sewers shall be tested for leakage.

901.7.1.2 The CONTRACTOR may Air Test the sanitary sewer line before backfilling the trench to aid the CONTRACTOR in checking the installation for any defects. Such testing is at the option of the CONTRACTOR and shall not constitute an acceptance test under these specifications.

901.7.1.3 The test for acceptance and compliance with these specifications shall be performed after the pipe zone backfilling has been completed. In the case of new sanitary sewer lines with house laterals included as an integral part of the project, the test for acceptance and compliance with these specifications shall be performed after the house laterals or stubs have been completed and backfilled. The CONTRACTOR has the option to leave the end of the service line exposed.

901.7.1.4 If the leakage, as shown by the test, is greater than allowed by these specifications, the pipe shall be overhauled at the CONTRACTOR's expense and, if necessary, re-laid until the pipe will satisfactorily pass the test.

901.7.1.5 The CONTRACTOR shall, at no additional expense to the OWNER, furnish all water, material, tools and labor for performing the required tests. All tests shall be made under observation of the ENGINEER.

901.7.2 INFILTRATION TEST:

901.7.2.1 An Infiltration Test shall be used only when excessive ground water prevents satisfactory testing by either the Exfiltration Test or the Air Test. In addition, the Infiltration Test must be performed after backfilling, before any service connections are functioning and at a time when the ground water is over the entire section of pipe and at or near its maximum level.

901.7.2.2 The procedure for conducting an Infiltration Test shall be as follows:

901.7.2.2.1 The pipe section shall be cleaned.

901.7.2.2.2 Determine the groundwater table. The groundwater table shall be determined for each section of sanitary sewer tested.

901.7.2.2.3 Plug the upstream pipe outlet from upstream manhole of the sections being tested with a plug which will assure a tight seal against flow from the upstream portion of the sewer system. Also plug all house laterals and any other connections to the section being tested.

901.7.2.2.4 Install a 90-degree V-notch weir in the downstream manhole of the section being tested. Weir must be installed plumb and sealed to the pipe wall surface.

901.7.2.2.5 A sufficient period of time must be allowed to permit the infiltrated waters to collect and flow over the weir. Water shall flow over the weir for at least 30-minutes prior to taking measurements.

901.7.2.2.6 The head (H) of water flowing over the weir must be measured accurately and the measurement taken at least 18-inches upstream from the crest of the weir.

901.7.2.2.7 Discharge over the 90-degree V-notch weir shall be calculated according to:

$$Q = 3240 H^{2.5}$$

H = Head in inches
Q = Discharge in gallons per day

901.7.2.3 The allowable infiltration shall be 200-gallons per inch of pipe diameter per mile of pipe per day. When there is significantly more than two feet of groundwater above the top of the pipe at the highest point of the section being tested, ten percent additional infiltration above the permitted 200 gal/in.-dia/mi/day limit will be allowed for every 2-foot of additional head.

901.7.2.4 Under all circumstances, the CONTRACTOR shall be required to remove all plugs prior to acceptance of

SECTION 901

SANITARY SEWER COLLECTOR AND INTERCEPTOR FACILITIES

the work. The Water Authority assumes no liability for damages caused by plugs inadvertently left in the line by the Contractor. The CONTRACTOR shall certify in writing to the Water Authority the completion of the plug removal task. The certification shall include the locations of removed plugs and corresponding date of removal.

901.7.3 EXFILTRATION TEST

901.7.3.1 An Exfiltration Test may be conducted wherever the groundwater level is below the crown of the pipe at the highest elevation of the section of sanitary sewer being tested. If the groundwater level is above the crown of the pipe either the Air Test, properly adjusted, or Infiltration Test should be used.

901.7.3.2 The procedure for conducting an Exfiltration Test shall be as follows:

901.7.3.2.1 The pipe section shall be cleaned.

901.7.3.2.2 Plug the downstream pipe outlet to the manhole with a plug which will assure a tight seal against water leakage. Also plug all house laterals and any other connections to the section being tested.

901.7.3.2.3 If the upstream manhole is to be used as a reservoir for maintaining the pressure head on the sewer pipe, the inlet sewer pipe of pipes must be plugged. If a standpipe is to be used as a reservoir for maintaining the pressure head on the sewer pipe, the standpipe must be connected to the sewer pipe in the upstream manhole by a tightly sealed connection.

901.7.3.2.4 The amount of water (volume required to fill the section of sewer under test plus the manhole or standpipe) shall be calculated.

901.7.3.2.5 Water shall then be introduced through the manhole or standpipe. The amount of water introduced shall be metered. The amount of water introduced to fill the sewer should be approximately equal to the calculated amount. If the amount of water required to fill the sewer pipe is significantly greater than the calculated amount, it is an indication of a leak or leaks and consequent saturation of the backfill around the sewer pipe. Saturation of the backfill will invalidate the test.

901.7.3.2.6 The level of water in the manhole or standpipe shall be at least two feet above the crown of the pipe at the highest section of the section of sanitary sewer being tested.

901.7.3.2.7 After filling the pipe at least one hour shall be allowed for water absorption in the pipe. For some materials, up to six hours may be required. After the absorption period, the manhole or standpipe shall be refilled to the established measuring mark and the test begun.

901.7.3.2.8 If the upstream manhole is used as a reservoir for maintaining the pressure head on the sewer pipe, the difference in water surface elevation from original to final level in a two hour period shall be used to calculate the water lost. The water lost in the two hour period shall be converted into gallons per day. If a standpipe is used as a reservoir for maintaining the pressure head on the sewer pipe, the standpipe shall be refilled periodically during the two-hour test period to maintain an essentially constant head on the test section of pipe. The amount of water added shall be measured and shall be used to calculate the loss in gallons per day.

901.7.3.2.9 The allowable exfiltration shall be computed based upon the average pressure head above the crown of the pipe for the section tested as follows:

$$\text{Allowable leakage} = \frac{\sqrt{h}}{\sqrt{3}} \times 200$$

Allowable leakage in gallons per inch of pipe diameter per mile of pipe per day

h = average pressure head above the crown of the pipe, in feet (elevation of water at center run)

901.7.3.2.10 When the upstream manhole is used as a reservoir for maintaining the pressure head, the allowable leakage from the manhole shall be added to the allowable leakage calculated for the sewer pipe.

901.7.3.3 If the sanitary sewer line fails to pass the Exfiltration Test, a re-test shall be permitted only after the groundwater conditions surrounding the pipe return to a condition similar to those existent at the beginning of the test period. The groundwater elevation shall be determined prior to initiation of a second test.

901.7.3.4 Under all circumstances, the CONTRACTOR shall be required to remove all plugs prior to acceptance of the work. The Water Authority assumes no liability for damages caused by plugs inadvertently left in the line by the Contractor. The CONTRACTOR shall certify in writing to the Water Authority the completion of the plug removal task. The certification shall include the locations of removed plugs and corresponding date of removal.

901.7.4 AIR TEST:

901.7.4.1 An Air Test may be conducted under all conditions of groundwater levels surrounding the sanitary sewer pipe. If the groundwater is above the crown of the pipe, the air pressure shall be increased by an increment equal to the pressure exerted by the groundwater over the pipe.

901.7.4.2 The procedure for conducting an Air Test shall be as follows:

SECTION 901

SANITARY SEWER COLLECTOR AND INTERCEPTOR FACILITIES

901.7.4.2.1 Clean the pipe section (manhole to manhole reach of sewer) being tested by propelling a snug-fitting inflated ball, or other adequate method, through the pipe with water. It is important that the pipe is thoroughly wetted if consistent results are to be expected.

901.7.4.2.2 Plug all pipe outlets with pneumatic plugs. The pneumatic plugs shall be able to resist internal testing pressures without requiring external bracing. Give special attention to house laterals.

901.7.4.2.3 Determine the groundwater level surrounding the section of sewer under test. If the groundwater level is above the crown of the pipe, the test pressures shall be increased by 0.43 psig for each foot of water above the average elevation of the crown of the pipe. If the average vertical height of groundwater above the pipe invert is more than 12.7 feet, the section so submerged shall be tested using 9.0 psig as the starting test pressure. In no case should the starting test pressure exceed 9 psig.

901.7.4.2.4 Introduce air slowly to the section of pipe under evaluation until the internal air pressure is raised to 4.0 psig plus any increase required by a high groundwater level.

901.7.4.2.5 Allow the air pressure to stabilize. Air may be added slowly to maintain a pressure in the 3.5 to 4.0 psig (plus groundwater allowance) for two minutes.

901.7.4.2.6 After the stabilization period, when the pressure reaches exactly 3.5 psig (plus groundwater allowance) the stopwatch is started and when the pressure

reaches exactly 2.5 psig (plus groundwater allowance) the stopwatch is stopped.

901.7.4.2.7 If the time required for a one pound pressure drop is not less than the allowable time for the pipe section under test to lose air, the section shall pass the leakage test.

901.7.4.2.8 If there has been no leakage (zero psi drop) after one hour of testing, the test section shall pass the leakage test.

901.7.4.3 In all cases where an Air Test is conducted, the manholes shall be tested separately as previously specified.

901.7.4.4 All persons conducting an Air Test must be aware that an Air Test may be dangerous if improperly conducted. It is extremely important and essential that all plugs be properly installed and braced by the CONTRACTOR in such a way that blowouts are prevented.

901.7.4.5 Under all circumstances, the CONTRACTOR shall be required to remove all plugs prior to acceptance of the work. The Water Authority assumes no liability for damages caused by plugs inadvertently left in the line by the Contractor. The CONTRACTOR shall certify in writing to the Water Authority the completion of the plug removal task. The certification shall include the locations of removed plugs and corresponding date of removal.

901.7.5 AIR TESTING TABLE: Table 901.7.5.1 will be used to determine the required test duration for the section of line being tested.

SECTION 901

SANITARY SEWER COLLECTOR AND INTERCEPTOR FACILITIES

TABLE 901.7.5.1
LOW-PRESSURE AIR TEST TIME SPECIFICATION
FOR A NON-PRESSURE SEWER LINE

901.7.5.2 EXPLANATION AND USE OF TABLE

Explanation of Tables

(A) Pipe Diameter (inches)	(B) Minimum Time (min:sec)	(C) Maximum Length for Minimum Time (feet)	(D) Time for Longer Length (seconds)	(E)								
				Specification Time for Length (L) Shown (min:sec)								
				100 ft	150 ft	200 ft	250 ft	300 ft	350 ft	400 ft	450 ft	
4	3:46	597	.38*L	3:46	3:46	3:46	3:46	3:46	3:46	3:46	3:46	3:46
6	5:40	398	.854*L	5:40	5:40	5:40	5:40	5:40	5:40	5:42	6:24	
8	7:34	298	1.52*L	7:34	7:34	7:34	7:34	7:36	8:52	10:08	11:24	
10	9:26	239	2.374*L	9:26	9:26	9:26	9:53	11:52	13:51	15:49	17:48	
12	11:20	199	3.418*L	11:20	11:20	11:24	14:15	17:05	19:56	22:47	25:38	
15	14:10	159	5.342*L	14:10	14:10	17:48	22:15	26:42	31:09	35:36	40:04	
18	17:00	133	7.692*L	17:00	19:13	25:38	32:03	38:27	44:52	51:16	57:41	
21	19:50	114	10.47*L	19:50	26:10	34:54	43:37	52:21	61:00	69:48	78:31	
24	22:40	99	13.674*									102:3
			L	22:47	34:11	45:34	56:58	68:22	79:46	91:10	3	
27	25:30	88	17.306*						100:5	115:2	129:4	
			L	28:51	43:16	57:41	72:07	86:32	7	2	8	
30	28:20	80	21.366*						124:3	142:2	160:1	
			L	35:37	53:25	71:13	89:02	106:50	8	6	5	
33	31:10	72	25.852*						150:4	172:2	193:5	
			L	43:05	64:38	86:10	107:43	129:16	3	1	3	
36	34:00	66	30.768*						179:2	205:0	230:4	
			L	51:17	76:55	102:34	128:12	153:50	9	7	6	
42	39:48	57	41.883*						244:1	279:1	314:0	
			L	69:48	104:42	139:37	174:30	209:24	9	3	7	
48	45:34	50	54.705*						319:0	364:4	410:1	
			L	91:10	136:45	182:21	227:55	273:31	6	2	7	
54	51:02	44	69.236*						403:5	461:3	519:1	
			L	4	173:05	230:47	228:29	346:11	3	4	6	
60	56:40	40	85.476*						498:3	569:5	641:0	
			L	8	213:41	284:55	356:09	427:23	7	0	4	

Column A Nominal diameter of pipe (any pipe material)

Column B Minimum duration of air test up to a maximum of length of line being tested -
(e.g., 0-feet through 298-feet of 8-inch PVC:
Test Duration: 7 minutes 34 seconds)

Column C Maximum length of line associated with minimum duration of time for the air test shown in Column B

SECTION 901

SANITARY SEWER COLLECTOR AND INTERCEPTOR FACILITIES

Column D of air test	L = length of line in feet; product of computation yields duration (e.g., 250-feet of 12-inch PVC where ground water is not present) Test Duration— $3.418 * (250) = 854.5 \text{ sec.} = 14 \text{ min. } 15 \text{ sec.}$
Column E	Duration of air test for given incremental lengths of line.

901.8 CLEANING AND INSPECTION

901.8.1 CLEANING: No pipe spalls, rocks, dirt, joint compounds, cement mortar and other trash or obstructions shall be left in a sewer pipe of any size or type. During the flushing operations the manhole outlet shall be bagged or plugged so that debris will not be carried into or contaminate an existing or active line.

901.8.1.1 Under all circumstances, the CONTRACTOR shall be required to remove all plugs prior to acceptance of the work. The Water Authority assumes no liability for damages caused by plugs inadvertently left in the line by the Contractor. The CONTRACTOR shall certify in writing to the Water Authority the completion of the plug removal task. The certification shall include the locations of removed plugs and corresponding date of removal.

901.8.2 TELEVISION:

901.8.2.1 All completed sewer lines shall be inspected by a television camera before lines become operational or final acceptance of the installation.

901.8.2.2 After the CONTRACTOR has cleaned, flushed, and retrieved all debris and plugs in the line, the CONTRACTOR will notify the project engineer that the line is ready for television inspection. The CONTRACTOR in the presence of the ENGINEER or the engineer's representative shall televise the line with televising equipment specifically designed and constructed for sewer line visual inspection.

901.8.2.2.1 The television camera shall be of color and equipped with a rotating lens capable of 360-degree rotation with zoom focus and a wide-angle optical lens permitting spontaneous focal adjustments, allowing viewing of service lateral connections, joints, pipe walls, etc.

901.8.2.2.2 A television report log, completed on the OWNER'S log form, shall be maintained during the television inspection. This log shall be completed to the OWNER'S satisfaction noting the location, project title, name of OWNER, date, type of pipe material, line size, location of services (live or stub-outs), manhole or station numbers, and any abnormal or line defects within the line segment.

901.8.2.2.3 The CONTRACTOR shall be responsible for subsequent televising when line repairs are required or when the previous televising is not satisfactory to the OWNER.

901.8.2.3 When the televising is complete, the CONTRACTOR shall turn over the complete television report logs and the recordings in a format acceptable to the Water Authority.

901.9 MEASUREMENT AND PAYMENT

901.9.1 SANITARY SEWER PIPE: Installed pipe shall be measured and paid for as follows:

901.9.1.1 For straight lines, the pipe length shall be the intervening distance between the centers of manholes along a line parallel to the pipe invert.

901.9.1.2 For curvilinear lines, the pipe length shall be the intervening arc distance between the centers of manholes along a line parallel to the pipe invert.

901.9.1.3 Payment for pipe will be in accordance with the unit price per linear foot per size and material as defined in the Bid Proposal, and shall include: pipe installed in the trench, jointing and coupling materials, and other materials necessary to connect to other sections of pipe, manholes, and other appurtenances.

901.9.2 CONNECTIONS: Connections, tying new sewer lines into existing manholes, shall be measured and paid for on a unit price per each within the size increments as specified in the Bid Proposal. Connections to the shelf section of the floor will not be considered for payment.

901.9.3 VERTICAL DROPS: Vertical drops at manholes shall be measured by the linear foot of pipe from the invert of the sewer line to be dropped to the spring line of the receiving main. Payment will be made on the unit price per linear foot per size and type of pipe as specified in the Bid Proposal.

901.9.4 TESTING:

901.9.4.1 Infiltration, exfiltration, and air tests of sewer mains shall include sewer service lines to the property lines, right-of-way lines, and easement lines as installed per the construction plans. No payment will be made for the initial test or subsequent tests.

SECTION 901

SANITARY SEWER COLLECTOR AND INTERCEPTOR FACILITIES

901.9.4.2 Television inspection and documentation is considered incidental and shall be included in the construction item's unit cost unless otherwise specified in the Bid Proposal.

901.9.4.3 There will be no payment for required testing of sanitary sewer manholes.

901.9.4.4 No payment will be made for deflection tests after the required waiting period for PVC sewer pipe installations.

901.9.5 REMOVAL AND DISPOSAL OF SANITARY SEWER PIPE: Removal and disposal of sanitary sewer lines shall be measured by the linear foot within the specified pipe size increments. Payment will be made on the unit price per linear foot of specified pipe size in the Bid Proposal. Trenching, backfilling, and pavement removal and replacement will be paid for based on the unit prices for each appropriate bid item in the Bid Proposal. If new pipe is to be installed in the same trench as the removed pipe, only one payment will be made for trenching backfilling, and pavement removal and replacement.

901.9.6 TRACE WIRE: Trace Wire: All work associated with the installation of the trace wire and system shall be considered incidental to the installation cost of the pipeline being traced.

SECTION 905

SANITARY SEWER SERVICE LINES

905.1 GENERAL

905.1.1 The requirements of this section apply only to sanitary sewer service lines installed or reconnected within the public right-of-way or easement. Although the maintenance of sanitary sewer lines is the responsibility of the property owner, including the portion within the public right-of-way as established by City Ordinance, the CONTRACTOR shall be responsible for the integrity of the installation or reconnection of all sanitary sewer service lines during the warranty period.

905.1.2 Sanitary sewer service lines shall be installed at all locations shown on the construction plans. The CONTRACTOR shall be aware of the importance of accurately recording coordinate horizontal and vertical locations of sanitary sewer service lines.

905.2 REFERENCES

905.2.1 ASTM:

- A 74 Standard Specification for Cast Iron Soil Pipe and Fittings
- D 1557 Standard Test Method for Laboratory Compaction Characteristics of Soil Using Modified Effort
- D 2661 Standard Specification for Acrylonitrile-Butadiene-Styrene (ABS) Schedule 40 Plastic Drain, Waste, and Vent Pipe and Fittings
- D 2665 Standard Specification for Poly (Vinyl Chloride) (PVC) Plastic Drain, Waste, and Vent Pipe and Fittings

905.2.2 This publication:

SECTION 170 Electronic Marker Devices

SECTION 701 Trenching, Excavation and Backfill

905.3 MATERIALS

905.3.1 Materials to be utilized on the project shall be those listed in the current Water Authority Approved Products List. All materials not listed must be submitted to the ENGINEER for approval no

less than thirty (30) calendar days prior to the proposed date of use.

905.3.2 The CONTRACTOR shall be responsible for assuring that the supplied saddle is compatible with the size and type of both the collection line and service line. Saddles shall be so constructed to have a positive stop to prevent service line from protruding into the main.

905.3.2.1 A 2½-inch wide strap will be required when saddle is attached to the collector line.

905.3.3 Materials to be utilized in the connection of sanitary sewer services to manholes shall be those listed in the current Water Authority Approved Products List. Manhole connections shall only be allowed if shown on the construction plans or approved by the ENGINEER.

905.3.4 Service risers, if required, shall be PVC Schedule 40 pipe conforming to ASTM D 2665, cast iron soil pipe (service weight) conforming to ASTM A 74, or ABS Schedule 40 sewer pipe conforming to ASTM D 2661. Only PVC or ABS shall be used when connecting to flexible pipe.

905.3.5 Fittings shall be compatible with the service line material. PVC or ABS fittings shall be schedule 40 injection molded only.

905.3.6 Service line laterals shall be cast iron soil pipe (service weight), PVC Schedule 40, or ABS Schedule 40.

905.4 INSTALLATION (NEW CONSTRUCTION STUB-OUTS)

905.4.1 Service lines shall be installed to the right-of-way line or 5-feet beyond any existing or proposed improvements (i.e., pavement, curb and gutter, sidewalk, etc.).

905.4.2 Saddle connections shall be installed at a 45-degree angle (upward) above the springline of the main sewer and shall be spaced a minimum of 3 feet apart (centerline to centerline).

905.4.3 Service lines shall be installed at a minimum slope of 2 percent with a minimum bury at the terminus of 4 feet, unless otherwise authorized by the ENGINEER. The pipe shall be placed on suitable bedding having a soil compaction density of not less than 95 percent of maximum density, as determined

SECTION 905

SANITARY SEWER SERVICE LINES

by ASTM D 1557. The pipe shall be uniformly supported by the bedding. Backfill of the service line shall be carefully placed and compacted per the requirements of Section 701.

905.4.4 The terminus of the service line shall be plugged with an end cap compatible with the pipe size and material. An electronic marker device shall be placed above the service tap at the main and over the end of the service line at the property line per Section 170. An "S" (3 inches high and ¼ inch depth) shall be stamped or saw-cut into top of the curb surface directly over the service.

905.4.5 RECORD INFORMATION: The CONTRACTOR shall provide coordinates, accurate to within 0.3 feet, determined from a field survey by a Professional Surveyor, licensed in the state of New Mexico, to the ENGINEER regarding the horizontal and vertical location of the service at the connection point to the public sewer collector line. Use the NAD 1983 NM STATE PLANE CENTRAL ZONE for x and y coordinates and NAVD 1988 for z coordinate. A report certified by the licensed Professional Surveyor shall be referenced on the Record Drawings.

905.5 RISERS

905.5.1 Risers shall be utilized where the sewer main is 15-feet or greater in depth. The riser shall extend to an elevation such that the service line can be installed as specified in Subsection 905.4.3.

905.5.2 The riser shall be installed in accordance with the Standard Detail Drawings. The riser shall be one length of pipe cut to the appropriate length as necessary, unless otherwise approved by the ENGINEER.

905.5.3 RECORD INFORMATION: The CONTRACTOR shall provide coordinates, accurate to within 0.3 feet, determined by a field survey by a Professional Surveyor, licensed in the state of New Mexico, to the ENGINEER regarding the horizontal and vertical location of the service. Coordinates shall be provided at the service tee and at the top elbow of the riser on the service. Use the NAD 1983 NM STATE PLANE CENTRAL ZONE for x and y coordinates and NAVD 1988 for z coordinate. A report certified by the licensed Professional Surveyor shall be referenced on the Record Drawings.

905.6 SERVICE RECONNECTIONS

905.6.1 On replacement/rehabilitation type projects, all existing services shall be reconnected to the new sewer main utilizing new saddles and service line pipe, except for Cured-In-Place rehabilitations. The length of removed existing service line shall be as necessary to accommodate the trench excavation and backfill conditions.

905.6.2 The CONTRACTOR shall visually assess the condition of the existing service line and notify the ENGINEER of any obviously deteriorated or defective conditions. The ENGINEER or CONTRACTOR shall notify the property owner of the situation and the property owner shall be given the opportunity to visually assess the service within a reasonable amount of time as dictated by normal construction activity.

905.6.3 The CONTRACTOR shall connect the new service line pipe to the existing pipe at the same slope and alignment as the existing service. Particular care shall be taken to assure a sound connection. The service line shall be uniformly supported on suitable bedding compacted to a density of not less than 95 percent of maximum density, as determined by ASTM D 1557. If service lines are reconnected such that the pipe is not fully supported, hand tampers shall be used to properly compact under the pipe.

905.6.4 The CONTRACTOR shall place an electronic marker device above the service connection to the public sewer line per Section 170.

905.6.5 The CONTRACTOR shall stamp or saw-cut an "S" (3 inches high and ¼ inch depth) into top of curb surface directly over the service line.

905.7 RECORD INFORMATION: The CONTRACTOR shall provide coordinates, accurate to within 0.3 feet, determined by a field survey by a Professional Surveyor, licensed in the state of New Mexico, to the ENGINEER regarding the horizontal and vertical location of the service. Coordinates shall be provided at the service tee or saddle tap, and if applicable at the top elbow of a riser. Use the NAD 1983 NM STATE PLANE CENTRAL ZONE for x and y coordinates and NAVD 1988 for z coordinate. A report certified by the licensed Professional Surveyor shall be referenced on the Record Drawings.

SECTION 905

SANITARY SEWER SERVICE LINES

905.8 MEASUREMENT AND PAYMENT

905.8.1 Sanitary sewer service lines installed on new construction shall be measured by the linear foot horizontally from the center of the sewer main, or top of riser, if applicable, to the end of the service line. Payment shall be made at the unit price per linear foot and shall include the saddle connection, pipe, trenching, compaction and backfill, electronic marker device, testing, and all incidental work necessary to complete the installation.

905.8.2 Sanitary sewer service risers shall be measured by the vertical foot from the top of the sewer main to the top of the riser. Payment shall be made at the unit price per vertical foot, and shall include the pipe and casing (if required).

905.8.3 Sanitary sewer service reconnections shall be measured per each. Payment shall be made at the unit price per each reconnection shall include the saddle connection, new service pipe, connection to the existing service line, and all incidental work necessary for a complete reconnection.

SECTION 910

STORM SEWER PIPE INSTALLATIONS

910.1 GENERAL

910.1.1 The construction items, specified in this section, are common to storm sewer pipe installation and pipe type culverts.

910.1.2 Reinforced concrete pipe shall be used for storm sewer pipe installations or pipe type culverts. Corrugated metal pipe may be used for pond outfall structures/risers and for stormwater infiltration. Polypropylene may be used under certain conditions; see Specification 912.

910.2 REFERENCES

910.2.1 ASTM

C361 Standard Specification for Reinforced Concrete Low Head Pressure Pipe

C443 Standard Specification for Joints for Concrete Pipe and Manholes, Using Rubber Gaskets

C478 Standard Specification for Precast Reinforced Concrete Manhole Sections

F2764 Polypropylene Pipe 6 to 60 inches

D3212 ASTM D3212 Plastic Pipe Joints

D2321 Underground Installation of Thermoplastic Pipe

F2881 Polypropylene Pipe 12 to 60 inches

F477 Elastomeric Seals of Joining Plastic Pipe

910.2.2 This publication per SECTIONS:

101 Portland Cement Concrete

102 Steel Reinforcement

105 Concrete Curing Compound

106 Cement Mortar and Grout

108 Brick

123 Reinforced Concrete Pipe

124 Reinforced Concrete Pressure Pipe

125 Vitrified Clay Pipe

135 Corrugated Metal Pipe and Arches (Steel)

161 Gray Iron Castings

910.3 MATERIALS

910.3.1 Pipe: Storm sewer line pipe and fittings shall be as specified in other sections as follows:

Section 123 Reinforced Concrete Pipe

Section 124 Reinforced Concrete Pressure Pipe

Section 135 Corrugated Metal Pipe and Arches
Arches, and Pipe Arches

910.4 CERTIFICATION

The OWNER/ENGINEER will be supplied with a certification on each item or type of material required in the storm sewer line, as to that item meeting the specifications and/or the reference specifications before that item is installed.

910.5 INSTALLATION

910.5.1 GENERAL:

910.5.1.1 Pipe and appurtenances shall be new and unused. The type of pipe to be installed shall be as approved by these specifications or unless otherwise shown on the drawings. Pipe and appurtenances shall be handled in such a manner as to insure delivery to the trench in sound, undamaged condition. Particular care shall be taken to prevent damage to any pipe coating.

910.5.1.2 The interior of the pipe shall be thoroughly cleaned of foreign material before being lowered into the trench and shall be kept clean during construction operations. When work is not in progress, the open ends of pipe shall be securely closed so that no foreign materials will enter the pipe. Any section of pipe found to be defective before or after laying shall be replaced with sound pipe, or repaired in a manner satisfactory to the ENGINEER, without additional expense to the owner.

910.5.1.3 Pipe shall be laid to line and grade as shown on the plans and as staked in the field. The bottom of the trench shall be graded and prepared to provide a firm and uniform bearing and bedding throughout the entire length of the pipe barrel. Suitable excavation shall be made to receive the bell of the pipe and the joint shall not bear upon the bottom of the trench. All adjustment to the line and grade shall be made by scraping or filling in with pipe zone material under the body of the pipe, and not by wedging or blocking. When connections are to be made to any existing manhole, pipe, or other improvement, the actual elevation or position of which cannot be determined without excavation, the CONTRACTOR shall excavate for and expose the existing improvement before laying the connecting pipe or conduit. When existing underground improvements may reasonably be expected to conflict with the line or grade established for the new

SECTION 910

STORM SEWER PIPE INSTALLATIONS

sewer line, the ENGINEER shall request and the CONTRACTOR shall excavate as necessary to expose and locate such potentially conflicting underground improvements prior to laying the new pipe. Any adjustment in line or grade which may be necessary to accomplish the intent of the plans will be made, and the CONTRACTOR will be paid for any additional work resulting from such change in line or grade in the manner provided for in the General Conditions.

910.5.1.4 CONTRACTOR shall submit to the ENGINEER the proposed method for making connections to existing manholes. Connection methods will be dependent upon manhole size and pipe sizes. Unnecessary damage to the existing manhole should be avoided.

910.5.1.5 Pipe shall be laid upgrade in a continuous operation from structure to structure, with the socket or collar ends of the pipe upgrade unless otherwise permitted by the ENGINEER. Concrete pipe with elliptical reinforcement shall be laid with the minor axis of the reinforcement cage in a vertical position. Corrugated metal pipe shall be laid with the external laps of the circumferential seams toward the inlet end.

910.5.1.6 Pipe penetrations into manholes shall not extend more than 2" into the manhole. The penetration hole shall be cleaned. There shall be a concrete collar on the exterior side of the penetration, and the interior side shall be grouted around the pipe.

910.6 JOINTS FOR PIPE

910.6.1 JOINTS FOR CONCRETE PIPE:

910.6.1.1 The type of joint to be used shall be O-ring rubber gasket joints conforming to ASTM C 361 and C 443.

910.6.1.2 Gasketed Type of Joints for Reinforced Concrete Pipe

910.6.1.2.1 General – The ends of the pipe shall be so formed that when the pipes are laid together and joined, they shall make a continuous and uniform line of pipe with a smooth and regular surface. The maximum joint gap width shall conform to manufacturer's specifications.

910.6.1.2.2 Rubber gaskets for making compression-type joints for concrete pipe shall be factory

fabricated in accordance with ASTM C 443; for pipes 12 inches in diameter and larger shall be O-ring and shall be handled, primed, installed, etc. in strict accordance with the manufacturer's recommendations.

910.6.1.2.3 The CONTRACTOR'S attention is particularly called to ASTM C 443, regarding storage of gaskets.

910.6.1.2.4 The CONTRACTOR shall furnish the ENGINEER complete information concerning the type and make of all joint material which he intends to use under the contract, including certification that the joint material meets the requirements of the specifications.

910.6.2 JOINTS FOR CORRUGATED METAL PIPE:

910.6.2.1 The seams of the pipe are to be placed at the sides, not on the bottom. The inside circumferential seams should be placed pointing downstream. Care should be taken to insure that dirt or other particles do not get between the outside of the pipe and the pipe coupling. Paved inverts should be placed and centered on the bottom of the trench. Any damage to the protective lining and coating shall be repaired prior to the backfilling around the pipe.

910.6.2.2 If waterproof joints are called for on the plans or specified in the Supplementary Specifications, the caulking compound or other waterproofing material used shall be subjected to the approval of the ENGINEER.

910.6.3 POLYPROPYLENE PIPE

910.6.3.1 Pipe shall be joined using a bell and spigot joint meeting the requirements of ASTM F2881 or ASTM F27674. The joint shall be watertight according to the requirements of ASTM D3212. Gaskets shall meet the requirements of ASTM F477. The gasket shall be installed by the pipe manufacturer and covered with a removable, protective wrap to ensure the gasket is free from debris. A joint lubricant available from the manufacturer shall be used on the gasket and bell during assembly. 12 through 60 inch (300 to 1500 mm) diameters shall have an exterior bell wrap installed by the manufacturer.

910.7 TESTING FOR LEAKAGE

SECTION 910

STORM SEWER PIPE INSTALLATIONS

Normally storm sewer lines need not be tested, but if in the opinion of the ENGINEER, the workmanship or materials do not appear to be satisfactory, the ENGINEER may require that a section of the storm sewer line be tested in a similar manner as that for a sanitary sewer line, see Section 901.

910.8 CLEANING AND INSPECTION

910.8.1 CLEANING: No pipe spalls, rocks, dirt, joint compounds, cement mortar and other trash or obstructions shall be left in a storm sewer pipe of any size or type. During flushing operations the manhole outlet shall be bagged or plugged so that the debris will not be carried into an existing active line.

910.8.2 INSPECTION: Before lines become operational or final acceptance of the installation. Lines larger than 18" in diameter and longer than 30 feet in length shall be inspected using Closed Circuit Television Camera (CCTV). Joint gaps or cracks that are larger than the Manufacturer's tolerances will not be accepted. Water ponding in the pipe deeper than 1" will not be accepted, nor will pipes with insufficient slope.

910.8.3 CLOSED CIRCUIT TELEVISION (CCTV): After the CONTRACTOR has cleaned and flushed the line, the CONTRACTOR will notify the ENGINEER that the line is ready for television inspection. The video is to be submitted to the City Storm Drain Inspector for review. If corrections are necessary, a new television inspection is to be submitted for review after the corrections are made. The cost of the inspection is included in the price of the storm drain.

910.9 MEASUREMENT AND PAYMENT

910.9.1 STORM SEWER PIPE: Installed pipe shall be measured and paid for as follows:

910.9.1.1 For straight lines the pipe length shall be the intervening distance between the centers of manholes along a line parallel to the pipe invert.

910.9.1.2 For curvilinear lines the pipe length shall be the intervening arc distance between the centers of manholes along a line parallel to the pipe invert.

910.9.1.3 For lateral lines, such as from main or manhole to a storm inlet, the pipe length shall be the distance between the center of a manhole or

centerline of the main to the interior wall face of the storm inlet along a line parallel to the pipe invert.

910.9.1.4 Payment for pipe will be in accordance with the unit price per linear foot per size and material as defined in the Bid Proposal, and shall include pipe installed in the trench, jointing and coupling materials, and other materials necessary to connect to other sections of pipe, manholes, and other appurtenances.

910.9.2 REMOVAL AND DISPOSAL OF SEWER PIPE: Removal and disposal of storm sewer pipe shall be measured by the linear foot within the specified pipe size increments. Payment will be made on the unit price per linear foot of specified pipe size in the Bid Proposal. Trenching, backfilling, and pavement removal and replacement will be paid for based on the unit prices for each appropriate bid item in the Bid Proposal. If new pipe is to be installed in the same trench as the removed pipe, only one payment will be made for trenching, backfilling, and pavement removal and replacement.

910.9.3 TESTING OF PIPE: No payment will be made for required initial or subsequent tests on sections of the storm sewer line.

SECTION 912

POLYPROPYLENE PIPE FOR STORM SEWERS

912.1 GENERAL

Polypropylene storm sewer pipe may be used in the City's right-of-way and under pavements for roadway functional classifications collector or less. Applications with greater traffic counts will need approval by the City Engineer.

912.2 REFERENCES

912.2.1 ASTM

D2321 Underground Installation of Thermoplastic Pipe for Sewers and Other Gravity-Flow Applications

D3212 Joints for Drain and Sewer Plastic Pipes Using Flexible Elastomeric Seals

F477 Elastomeric Seals (Gaskets) for Joining Plastic Pipe

F2764 6 to 60 in. (150 to 1500 mm) Polypropylene (PP) corrugated Double and Triple Wall Pipe and fittings for Non-Pressure Sanitary Sewer Applications

F2881 12 to 60 in. (300 to 1500 mm) Polypropylene (PP) Dual wall Pipe and Fittings for Non-Pressure Storm Sewer Applications

D1557 Standard Test Methods for Laboratory Compaction Characteristics of Soil Using modified Effort (56,000 ft-lbf/ft³ (2,700 kN- m/m³))

912.2.2 This publication per SECTIONS:

701 -- Trenching, Excavation and Backfill

910 -- Storm Sewer Pipe Installations

912.3 MATERIALS

912.3.1 Delivery, Storage, and Handling -- All pipe and fittings shall be delivered to the site and unloaded with handling that conforms to the manufacturer's instructions for reasonable care. Pipe shall not be rolled or dragged over gravel or rock during handling. The Contractor shall take necessary precautions to ensure the method used in lifting or placing the pipe does not induce undue stress fatigue in the pipe.

912.3.2 Not used.

912.3.3 Six through 60-inch (150 through 1500 mm) pipe shall be polypropylene or pre-approved equal. Pipe supplied shall be with annular inner corrugations and smooth interior and exterior surfaces, corrugated polypropylene (PP) pipe meeting the requirements of ASTM F2764 for respective diameters. The pipe supplied shall be watertight as defined in the joint performance requirements of this specification.

912.3.4 The pipe supplied shall be watertight as defined in Section 912.6.3.

912.3.5 Virgin material for 12- through 60-inch pipe and fitting production shall be an impact modified copolymer meeting the material requirements of ASTM F2764 for respective pipe diameters.

912.3.6 Pipe stiffness - Minimum pipe stiffness at 5% deflection shall meet the requirements per ASTM F2764.

912.4 CERTIFICATION

The OWNER/ENGINEER will be supplied with a certification on each item or type of material required in the storm sewer line, as to that item meeting the specifications and/or the reference specifications before that item is installed.

912.5 INSTALLATION

912.5.1 Pipe and fittings shall be inspected prior to installation and any defective or damaged product shall be replaced. Any pipe or fittings with cuts, punctures, or other damage on the interior or exterior shall be rejected and replaced. Any pipe or fittings with damaged ends or joints, which would prevent proper sealing of the joints, shall be rejected and replaced.

912.5.2 All products shall be inspected for defects and cracks before being lowered into the trench, piece by piece. Any defective, damaged or unsound pipe or fittings, or any product that has had its grade disturbed after laying, shall be taken up and replaced. Open ends shall be protected with a pipe plug to prevent earth or other material from entering the pipe during construction. The interior of the pipe shall be free from dirt, excess water and other foreign materials as the pipe laying progresses and left clean at the completion of the installation.

912.5.3 Install piping system beginning at low point, true to grades and alignment indicated with unbroken continuity of invert. Place bell ends of piping facing upstream. Install gaskets, seals, sleeves, and

SECTION 912

POLYPROPYLENE PIPE FOR STORM SEWERS

couplings according to manufacturer's written instructions. Follow product manufacturer's instructions for the use of lubricants, cements, and other special installation requirements.

912.5.4 Do not lay or embed pipe or fittings in standing or running water. At all times prevent runoff and surface water from entering the trench.

912.5.5 When water is present in the work area, dewater to maintain stability of in-situ and imported materials. Maintain water level below pipe bedding and foundation to provide a stable trench bottom. Use, as appropriate, sump pumps, well points, deep wells, geofabrics, perforated underdrains, or stone blankets of sufficient thickness to remove and control water in the trench. When excavating while depressing ground water, ensure the ground water is below the bottom of cut at all times to prevent washout from behind sheeting or sloughing of exposed trench walls. Maintain control of water in the trench before, during, and after pipe system installation and until embedment is installed and sufficient backfill has been placed to prevent flotation of the pipe, fitting, or drainage structures. To preclude loss of soil support, employ dewatering methods that minimize removal of fines and the creation of voids in in-situ materials.

912.5.6 Rock in either ledge or boulder formation shall be replaced with suitable materials to provide a compacted earth cushion having a thickness between exposed rock and the pipe of at least 12 inches (0.3m). Where Bell-and-Spigot pipe is used, the cushion shall be maintained under the bell as well as under the straight portion of the pipe.

912.5.7 Where wet or otherwise unstable soil incapable of properly supporting the pipe system, as determined by the Engineer, is encountered in the bottom of a trench, such material shall be removed to at least 24 inches below bottom of pipe and replaced to the proper grade with select granular material, compacted as directed by the engineer. When removal of unstable material is due to the fault or neglect of the Contractor while performing shoring and sheeting, water removal, or other specified requirements, such removal and replacement shall be performed at no additional cost to the Owner.

912.5.8 A stable and uniform bedding shall be provided for the pipe and any protruding features of its joint and/or fittings. The middle of the bedding, equal to one-third of the pipe outside diameter, shall be loosely placed while the remainder shall be compacted to a minimum of 90% of maximum

density per ASTM D1557, or as shown in the plans. Pipe bedding shall be a minimum of 4" – 6" in thickness. The bedding surface for the pipe shall provide a firm foundation of uniform density throughout the entire length of the pipe.

912.5.9 Each pipe shall be thoroughly examined before being laid; defective or damaged pipe shall not be used. Pipelines shall be laid to the grades and alignment indicated. Proper facilities shall be provided for lowering sections of pipe into trenches. Pipe shall not be laid in water, and the pipe shall not be laid when trench conditions or weather are unsuitable for such work. Diversion of drainage or dewatering of trenches shall be provided as directed by the engineer; see dewatering section.

912.5.10 Class 1 or 2 backfill materials per ASTM D2321 may be used for the bedding, haunch, and initial backfill zones per the Standard Drawings. Class 3 backfill materials per ASTM D2321 may be used with pipes having a stiffness greater than 9 psi.

912.6 JOINTS FOR PIPE

912.6.1 All pipe supplied shall meet the minimum joint performance requirements as defined herein and as further defined in the joint performance requirements of this specification.

912.6.2 Watertight joints shall be bell-and-spigot and gaskets shall be made of polyisoprene meeting the requirements of ASTM F477.

912.6.3 Pipe shall meet the minimum joint performance requirements per ASTM D3212, a 10.8 psi gage (104kPa) laboratory pressure test for 10 minutes with no visible leaks at the joint. Piping shall pass same tests as above but with an axial joint misalignment of not less than 1 degree.

912.6.4 All Bell-and-Spigot pipe joints shall be thoroughly cleaned. Joint lubricant, supplied by the manufacturer, shall be liberally applied to entire interior of bell and gasket on spigot prior to assembly.

912.7 BACKFILLING

912.7.1 General: Backfill placement and compaction shall be constructed in accordance with the specifications herein and the product manufacturer's published installation guides.

912.7.2 Backfilling Pipe in Trenches: After the pipe and pipe system have been properly bedded, selected

SECTION 912

POLYPROPYLENE PIPE FOR STORM SEWERS

material from excavation or borrow, at a moisture content that will facilitate compaction, shall be placed along both sides of pipe in layer depths to ensure minimum compaction density is obtained evenly throughout the backfill material. The backfill shall be brought up evenly on both sides of pipe and pipe system for the full length of pipe. The fill shall be thoroughly compacted under the haunches of the pipe. Each layer shall be thoroughly compacted with mechanical tampers or rammers. This method of filling and compacting shall continue until the fill has reached the top of the pipe. The remainder of the trench shall be backfilled and compacted by spreading and rolling or compacted by mechanical rammers or tampers. Tests for density shall be made as necessary to ensure conformance to the compaction requirements specified below.

912.7.3 Backfilling Pipe in Fill Sections: For pipe placed in fill sections, fill shall be constructed to at least 6 inches above the top of proposed pipe prior to trench excavation. Fill shall be placed in 12 inch lifts and shall be compacted to achieve 90% of maximum density (per ASTM D1557), or as shown on plans. Once fill is placed and compacted pipe trench shall be constructed in accordance with the Trench Excavation section of this specification.

912.7.4 Movement of Construction Machinery: When compacting by rolling or operating heavy equipment parallel with the pipe, displacement of or injury to the pipe shall be avoided. Movement of construction machinery over a culvert or storm drain at any stage of construction shall be at the Contractor's risk. Any damaged pipe shall be repaired or replaced.

912.7.5 Compaction

912.7.5.1 General Requirements: Non-cohesive materials include gravels, gravel-sand mixtures, sands, and gravelly sands. Cohesive materials include clayey and silty gravels, gravel-silt mixtures, clayey and silty sands, sand-clay mixtures, silts, and very fine sands. When results of compaction tests for moisture-density relations are recorded on graphs, non-cohesive soils will show straight lines or reverse-shaped moisture-density curves, and cohesive soils will show normal moisture-density curves.

912.7.5.2 Minimum Density: Backfill over and around the pipe and backfill around and adjacent to drainage structures shall be compacted at the approved moisture content to the following applicable minimum density, which will be

determined as specified below. Compaction shall be to a density of not less than 90% of maximum density, as determined by ASTM D 1557. The moisture content shall not exceed 5 percent above optimum

912.7.6 Determination of Density: Testing shall be performed by an approved commercial testing laboratory or by the Contractor subject to approval by the Engineer. Tests shall be performed in sufficient number to ensure that specified density is being obtained. Laboratory tests for moisture-density relations shall be made in accordance with ASTM D1557 except that mechanical tampers shall be used provided the results are correlated with those obtained with the specified hand tamper. Field density tests shall be determined in accordance with ASTM D2167 or ASTM D2922. Test results shall be furnished to the Engineer.

912.8 TESTING FOR LEAKAGE

Normally storm sewer lines need not be tested, but if in the opinion of the ENGINEER, the workmanship or materials do not appear to be satisfactory, the ENGINEER may require that a section of the storm sewer line be tested in a similar manner as that for a sanitary sewer line, see Section 901.

912.9 CLEANING AND INSPECTION

912.9.1 CLEANING: No pipe spalls, rocks, dirt, joint compounds, cement mortar and other trash or obstructions shall be left in a storm sewer pipe of any size or type. During flushing operations the manhole outlet shall be bagged or plugged so that the debris will not be carried into an existing active line.

912.9.2 INSPECTION: Before lines become operational or final acceptance of the installation, small size lines shall be inspected by a television camera and larger size lines will be inspected by walking through the line.

912.9.3 TELEVISION: After the CONTRACTOR has cleaned and flushed the line, the CONTRACTOR will notify the ENGINEER that the line is ready for television inspection. Prior to the television inspection (possibly during flushing operation) the CONTRACTOR will insert a ¼ inch nylon rope in the line for the purpose of towing the television unit through the pipe. The OWNER will perform the first television inspection at no cost to the CONTRACTOR. If during the first inspection debris is found in the line, the television inspection will cease. When further cleanup has been completed, the

SECTION 912

POLYPROPYLENE PIPE FOR STORM SEWERS

CONTRACTOR will request the ENGINEER to have a second inspection performed. The cost of the second inspection and any subsequent inspections of that segment of the line will be paid for by the CONTRACTOR at the rate of \$50.00 per hour while the television crew is at the line site.

912.10 MEASUREMENT AND PAYMENT

912.10.1 STORM SEWER PIPE: Installed pipe shall be measured and paid for as follows:

912.10.1.1 For straight lines the pipe length shall be the intervening distance between the centers of manholes along a line parallel to the pipe invert.

912.10.1.2 For curvilinear lines the pipe length shall be the intervening arc distance between the centers of manholes along a line parallel to the pipe invert.

912.10.1.3 For lateral lines, such as from main or manhole to a storm inlet, the pipe length shall be the distance between the center of a manhole or centerline of the main to the interior wall face of the storm inlet along a line parallel to the pipe invert.

912.10.1.4 Payment for pipe will be in accordance with the unit price per linear foot per size and material as defined in the Bid Proposal, and shall include pipe installed in the trench, jointing and coupling materials, and other materials necessary to connect to other sections of pipe, manholes, and other appurtenances.

912.10.2 REMOVAL AND DISPOSAL OF SEWER PIPE: Removal and disposal of storm sewer pipe shall be measured by the linear foot within the specified pipe size increments. Payment will be made on the unit price per linear foot of specified pipe size in the Bid Proposal. Trenching, backfilling, and pavement removal and replacement will be paid for based on the unit prices for each appropriate bid item in the Bid Proposal. If new pipe is to be installed in the same trench as the removed pipe, only one payment will be made for trenching, backfilling, and pavement removal and replacement.

912.10.3 TESTING OF PIPE: No payment will be made for required initial or subsequent tests on sections of the storm sewer line.

SECTION 915

STORM SEWER DRAINAGE APPURTENANCES

915.1 GENERAL – The construction items, specified in this section, are related to the storm sewer underground facilities.

915.2 REFERENCES

915.2.1 This publication:

SECTION 300 Streets and Related Work

SECTION 501 Excavation and Backfill for Structures

SECTION 701 Trenching, Excavation and Backfill

915.3 MATERIALS

915.3.1 The construction plans will specify the size and material for the pipe between the storm sewer main and the storm water collection structure.

915.3.2 The various types of storm inlets and their relation to curb and gutter, or valley gutter are shown in the Standard Detail Drawings. Construction plans will identify the type to be constructed.

915.3.3 Grating size, material, and configuration shall conform to the Standard Detail Drawings.

915.4 INSTALLATION OF DRAINAGE FACILITIES

915.4.1 Excavation and backfilling for the storm inlet shall be accomplished in accordance with Section 501.

915.4.2 Trenching, backfilling, and compaction for the connecting pipe between the storm sewer main and the storm inlet shall conform to the specification contained in Section 701. Pipe shall be installed in accordance with Section 910.

915.4.3 All pipe and structures shall be installed per location and elevations, as shown on the construction plans. If during the course of installation, an underground obstruction (i.e., existing utility line) the work shall stop and the ENGINEER shall be immediately notified so that the problem can be resolved.

915.4.4 Direct connection to storm sewer main will be permitted if the main is a minimum of 36 inches in diameter (I.D.) and the connecting line is not greater than 12 inches (I.D.). If storm sewer mains are 48 inches (I.D.) or larger, the connecting line diameter may be increased to 18 inches (I.D.). For connecting

line sizes greater than those specified above, the connection to the main will be made into a manhole or by inserting into the main a factory constructed wye. Connection to the main will comply with the Standard Detail Drawings.

915.4.5 Removal of curb and gutter, and sidewalk for installation of a storm inlet shall be made at a scored or full depth joint.

915.4.6 Existing pavement removal and replacement shall conform to Sections 343 and shall conform to residential or arterial pavement sections of the same material (asphalt or Portland Cement concrete) as the existing pavement.

915.4.7 No width greater than ½ inch will be permitted between the inlet grate and the roadside portion of the inlet frame.

915.5 Private drainage facility installations, which are to be constructed under the authorization of “Drainage Facilities Within Public Right-of Way,” shall comply with the Standard Detail Drawings and appropriate sections of this publication.

915.6 MEASUREMENT AND PAYMENT

915.6.1 Pavement removal and replacement will be measured by square yard. Payment will be made at the unit price per square yard per type of replacement paving material, as specified in the Bid Proposal.

915.6.2 Trenching, backfilling, and compaction shall be measured by the linear foot from the main side wall of the inlet to the centerline of the main. Payment will be made at the unit price per linear foot per the average depth increment between connection points, as defined in the Bid Proposal.

915.6.3 Connecting pipe shall be measured by the linear foot along centerline of pipe from the main side wall of the inlet to the centerline of the main. Payment will be made at the unit price per linear foot per type and size of pipe, and shall include pipe in place and all necessary jointing materials.

915.6.4 Storm inlets shall be measured on a unit basis. Payment will be made at the unit price per each type of storm inlet, and shall include structure, grating, excavation, backfilling and compaction, and curb removal and replacement, as defined in Bid Proposal.

SECTION 915

STORM SEWER DRAINAGE APPURTENANCES

915.6.5 Removal and replacement of sidewalk shall be measured by the square foot and payment will be made at the unit price per square foot.

SECTION 920

SANITARY SEWER MANHOLES

920.1 GENERAL: This section contains items which are relative to the installation and rehabilitation of sanitary sewer manholes.

920.2 REFERENCES

920.2.1 ASTM

C 32 Standard Specification for Sewer and Manhole Brick (Made From Clay or Shale)

C 139 Standard Specification for Concrete Masonry Units for Construction of Catch Basins and Manholes

C 478 Standard Specification for Precast Reinforced Concrete Manhole Sections

C 497 Standard Test Methods for Concrete Pipe, Manhole Sections, or Tile

D 1557 Standard Test Methods for Laboratory Compaction Characteristics of Soil Using Modified Effort

920.2.2 This publication:

SECTION 101	PORTLAND CEMENT CONCRETE
SECTION 102	STEEL REINFORCING
SECTION 105	CONCRETE CURING COMPOUND
SECTION 106	CEMENT MORTAR AND GROUT
SECTION 108	BRICK
SECTION 161	GRAY IRON CASTINGS
SECTION 163	DUCTILE IRON CASTINGS
SECTION 170	ELECTRONIC MARKER DEVICES

920.3 MATERIALS

920.4 SANITARY SEWER MANHOLE CONSTRUCTION

920.4.1 GENERAL

920.4.1.1 Soil Foundations for manhole base shall be compacted to a density of 95 percent of the maximum density per ASTM D 1557. Compaction limits shall be one foot beyond the perimeter of the concrete base and shall be a minimum of one foot in depth.

920.4.1.2 Manholes shall be constructed in accordance with the Standard Detail Drawings and as shown on the construction plans. Precast reinforced concrete units, concrete blocks or formed in-place, reinforced concrete may be used to construct manhole.

920.4.1.3 Invert elevation of the pipes entering or exiting the manhole and interior inverts shall not vary more than 0.05 feet from the elevation indicated on the construction plans. In order to ensure compliance with the design drawings, the CONTRACTOR shall provide the ENGINEER with coordinates, obtained by a Professional

Surveyor licensed in the state of New Mexico. The vertical precision of the coordinates shall be, at a minimum, accurate to within 0.05 feet. Use the NAD 1983 NM STATE PLANE CENTRAL ZONE for x and y coordinates and NAVD 1988 for z coordinate.

920.4.1.4 All cement used for poured foundations, mortar, fillets, grout, and concrete shelf construction shall be Type II or approved equal.

920.4.1.5 All concrete for formed in place foundations or bases, concrete shelves, and pipe supports shall conform to Section 101.

920.4.1.6 Depending on the size of the pipe, connections to existing and new manholes shall be made by either core drilling through the manhole wall, preformed for new precast units, or for large-size pipe the manhole wall may be removed by carefully chipping the wall segment which will permit entry of the pipe. In the latter operation, exposed manhole reinforcement should be bent and tied to the reinforcement of the pipe tied to the reinforcement of the pipe collar. If core drilling is not practical, the CONTRACTOR shall request the ENGINEER to authorize the chipping operation. During either operation the CONTRACTOR shall take care to avoid unnecessary damage to the manhole surfaces or walls.

920.4.1.7 Electronic marker devices shall be installed at all sanitary sewer manholes, one foot upstream of the manhole over the centerline of the main line as specified in Section 170.

920.4.2 PRECAST CONCRETE MANHOLES:

920.4.2.1 The vertical sections of the manhole may be of different dimensions in order that manholes of various depths can be readily assembled.

920.4.2.2 Concrete, used for precast bases, vertical sections, and concentric cones, shall conform to Section 101.

920.4.2.3 Vertical sections of the manhole shall conform to the requirements of ASTM C 478.

920.4.2.4 The CONTRACTOR shall submit shop drawings of the precast base and concentric cone to the ENGINEER for review and approval.

920.4.2.5 Circular precast manhole sections shall be provided with mastic gasket to seal joints between sections. Material used shall conform to the Water Authority Approved Product List.

920.4.2.6 All lifting holes, except Type "C" manhole covers, and gaps at joints shall be filled with a non-shrink grout.

SECTION 920

SANITARY SEWER MANHOLES

920.4.2.7 Precast concrete manhole bases may be used when approved by the ENGINEER. If approved, it shall be with the understanding that the CONTRACTOR shall be responsible for placing the bases at the specified elevation, location, and alignment.

920.4.3 FORMED-IN-PLACE REINFORCED CONCRETE MANHOLE:

920.4.3.1 The CONTRACTOR shall submit preconstruction drawings of the proposed manholes to the ENGINEER for review and approval.

920.4.3.2 Concrete used for this type of manhole construction shall conform to Section 101.

920.4.3.3 If desired, a precast concentric cone or a flat top cover can be used.

920.4.4 CONCRETE BLOCK MANHOLE:

920.4.4.1 The CONTRACTOR shall submit preconstruction drawings of the proposed manhole to the ENGINEER for review and approval.

920.4.4.2 Concrete masonry units for the construction of this type of manhole shall conform to ASTM C 139 and the Standard Detail Drawings. All blocks shall be mortared into place.

920.4.4.3 Concentric cone or flat top cover shall be used.

920.4.5 (intentionally left blank)

920.4.6 COATING OF MANHOLES:

920.4.6.1 Exterior of Manholes: Exterior coating of manholes shall be required in areas where ground water is present. The coating shall be a waterproofing type of bitumastic or asphaltic material, as approved by the ENGINEER. Application shall be in accordance with the manufacturer's published recommendations.

920.4.6.2 Interior of Manholes: Interior coating of manholes shall be required only when specified on the construction plans. The coating shall be an epoxy resin-type material, listed on the Water Authority Approved Product List, and shall be capable of protecting the concrete from deterioration due to a gaseous environment. Application shall be in accordance with the manufacturer's published recommendations.

920.4.6.3 Plastering of Manholes: The work shall include the coating of the surface of existing block manholes with plaster as required on the construction plans.

920.4.7 (intentionally left blank):

920.4.8 ADJUSTMENT BRICKS:

920.4.8.1 Manhole adjustment bricks shall conform to the requirements for manhole bricks, per ASTM C 32 for Grade MS.

920.4.8.2 Mortar shall be used to lay the bricks, as well as coating the interior and exterior surfaces of the laid brick. Thickness of the mortar coating shall be 1/2-inch.

920.4.9 MANHOLE FRAME AND COVER:

The manhole frame and cover for the sanitary sewer shall conform to the specifications contained in Section 163 Ductile Iron Castings.

920.5 LEAKAGE TESTING OF SEWER MANHOLES:

920.5.1 All sanitary sewer manholes shall be tested for leakage by either a water exfiltration test or a vacuum test. Whichever leakage test is utilized, it is recommended that the test be performed prior to backfilling around the manhole and prior to placement of the manhole frame and cover. All inlet and outlet lines shall be properly plugged and the lift holes and barrel joints filled and sealed as specified. The CONTRACTOR shall be responsible for all materials and equipment necessary to perform the test and shall conduct the test in the presence of the ENGINEER or his representative. The CONTRACTOR has the option of performing a manhole test in increments appropriate to the depth of the manhole.

920.5.1.1 Under all circumstances, the CONTRACTOR shall be required to remove all plugs immediately after testing and prior to acceptance of the work. The Water Authority assumes no liability for damages caused by plugs inadvertently left in the line by the Contractor. The CONTRACTOR shall certify in writing to the Water Authority the completion of the plug removal task. The certification shall include the locations of removed plugs and corresponding date of removal.

920.5.2 The water exfiltration test shall consist of filling the entire manhole with water to the bottom of the frame elevation. A stabilization period of one hour will be allowed for absorption, after which the manhole shall be refilled as necessary before starting the test. The test period shall be two (2) hours, after which the manhole shall be refilled, measuring the necessary quantity of water. The allowable leakage shall be 0.25 gallons per foot diameter per vertical foot per day and is represented by the following formula:

$$V = 0.25 \text{ DHT} / 24$$

Where: V = Allowable loss in gallons
D = Manhole diameter in feet
H = Initial depth of water to invert in feet
T = Duration of test in hours

SECTION 920

SANITARY SEWER MANHOLES

920.5.3 The vacuum test shall consist of utilizing an inflatable compression band, vacuum pump, gauges and appurtenances specifically designed for vacuum testing. Test procedures shall be in accordance with the manufacturer's printed recommendations. The ENGINEER shall be the sole judge as to the adequacy of the equipment.

920.5.3.1 A vacuum of 10" Hg shall be placed in the manhole and the time measured for a drop to 8.5" Hg. The test shall be considered to be successful if the measured time exceeds the test period. Should the test fail, the manhole shall be repaired as necessary and the test rerun. The test periods are:

920.5.3.2 Sixty (60) seconds for four (4) foot diameter manholes

920.5.3.3 Seventy-five (75) seconds for five (5) foot diameter manholes

920.5.3.4 Ninety (90) seconds for six (6) foot diameter manholes

920.5.3.5 One hundred and twenty (120) seconds for eight (8) foot diameter manholes

920.6 ABANDONMENT OF MANHOLES

920.6.1 Abandonment of manhole, which is part of a sewer line being abandoned, shall require the following work and materials:

920.6.2 Manhole will not be removed but will be abandoned in place.

920.6.3 All manhole inlet and outlet lines shall be plugged with a 12-inch thick concrete or concrete mortar plug.

920.6.4 The concrete collar, ring, and cover shall be removed and disposed of by the CONTRACTOR.

920.6.5 Manhole bottom will be pulverized.

920.6.6 The manhole shall be filled with cement treated base (CTB) material to the bottom elevation of the asphalt base course of the pavement or to the ground surface level.

920.6.7 All labor, materials, and equipment necessary to complete this work shall be furnished by the CONTRACTOR.

920.6.8 For historical information the ENGINEER shall provide coordinates accurate to within 0.3 feet, obtained by a Professional Surveyor licensed in the state of New Mexico, on the record drawings. Use the NAD 1983 NM STATE PLANE CENTRAL ZONE for x and y coordinates and NAVD 1988 for z coordinate.

920.7 SANITARY SEWER MANHOLE REHABILITATION

920.7.1 GENERAL

920.7.1.1 Sanitary sewer manhole rehabilitation shall include coating of manholes with a cementitious liner, rebuilding of manhole invert benches to the profile shown on Standard Drawings 2101 and 2102 or to the specific profiles provided on the construction plans, and installation of protective epoxy or polyurethane coating systems. Where shown on the construction plans, sanitary sewer manhole rehabilitation shall also include miscellaneous structural modifications including installation of 30-inch diameter opening with approved manhole cover and frame, and installation of new concrete collar.

920.7.2 SANITARY SEWER MANHOLE REHABILITATION ASSOCIATED WITH TRENCHLESS REHABILITATION WORK

920.7.2.1 This specification shall govern all work, materials, and equipment required for new manhole lining or manhole rehabilitation for the purpose of eliminating infiltration, providing corrosion protection, repair of voids, and restoration of the structural integrity of the manhole as a result of applying a monolithic fiber-reinforced cementitious liner to the wall and bench surfaces of brick, concrete, or any other construction material followed by a protective epoxy or polyurethane coating system, where specifically required on the construction plans.

920.7.2.2 For sliplining and cured-in-place pipe technologies where no point of intersection occurs in the manhole, the sewer liner may be installed continuous through the manhole. If installed in this manner, the portion within the manhole shall be neatly cut out and removed, and terminations sealed per liner manufacturer's recommendation. For those manholes where point of intersections occur in the manholes, the sewer liner shall be terminated and sealed per liner manufacturer's recommendation at the inside wall of the manhole. For those sewer rehabilitation methods that require annular grouting, a bulkhead shall be installed. The manhole shall be thoroughly cleaned using a high pressure washing system as recommended. A new bench shall be constructed to the pipe soffit and the manhole wall sealed with a monolithic, cementitious liner followed by application of a protective epoxy or polyurethane coating system.

920.7.2.3 Described are procedures for manhole preparation, cleaning, application and testing. The applicator, approved and trained by the manufacturer, shall furnish all labor, equipment and materials for applying a cementitious mix to form a monolithic liner of minimum 1/2-inch thickness using a machine specially designed for the application.

SECTION 920

SANITARY SEWER MANHOLES

920.7.2.3.1 All aspects of the installation shall be in accordance with the manufacturer's recommendations and with the following specifications which include: Elimination of all infiltration prior to making the application; Repair and sealing the invert benches; Removal of any loose and unsound material; Re-building of manhole invert benches to the pipe soffit; Spray application of a cementitious liner mix to form a monolithic liner; and Spray application of a protective epoxy or polyurethane liner system.

920.7.3 MATERIALS

920.7.3.1 All materials used shall be listed on the Water Authority Approved Product list.

920.7.3.1.1 Patching Mix: a quick setting fiber reinforced, calcium aluminate, corrosion resistant cementitious material shall be used as patching material to fill large voids.

920.7.3.1.2 Infiltration Control: a rapid setting cementitious product specifically formulated for leak control shall be used to stop minor water infiltration of water into the manhole.

920.7.3.1.3 Grouting Mix: a cementitious grout shall be used for stopping active infiltration into the manhole and filling voids in the manhole wall. Chemical grouts may be used to stop excessively active infiltration.

920.7.3.1.4 Cementitious Liner Mix: shall be used to form the monolithic liner covering all interior manhole surfaces. The liner mix shall be made with calcium aluminate cement or other approved corrosion preventative admixture and shall be applied according to the manufacturer's recommendations.

920.7.3.1.5 Protective Epoxy or Polyurethane Liner: shall be used to resist chemical attack and deterioration of the manhole walls.

920.7.4 SUBMITTALS AND CERTIFICATIONS

920.7.4.1 Before commencing work, the CONTRACTOR shall submit the following for Approval:

920.7.4.1.1 Technical Data Sheets for proposed materials.

920.7.4.1.2 Certifications that the proposed materials meet or exceed the requirements listed in the Specifications.

920.7.4.1.3 Installation procedures as recommended by the manufacturer.

920.7.4.1.4 Product testing results.

920.7.4.1.5 Design calculations.

920.7.4.1.6 Applicator qualifications and proof of manufacturer training.

920.7.5 APPLICATION

920.7.5.1 PREPARATION, CLEANING, AND LEAK PREVENTION

920.7.5.1.1 Place covers over sewer invert to prevent extraneous material from entering the lines.

920.7.5.1.2 All foreign material, deposits, and other contaminants shall be removed from the manhole wall and bench using a high pressure washer or water sprayer having a minimum nozzle discharge pressure of 1,200 psi. Care shall be taken not to cause additional damage to the manhole structure resulting from overpressure used in cleaning process.

920.7.5.1.2.1 Loose and protruding brick, mortar, and concrete shall be removed using a mason's hammer and chisel and/or scraper.

920.7.5.1.2.2 Large voids shall be filled with quick setting patching mix.

920.7.5.1.2.3 Active leaks shall be stopped using quick setting specially formulated mixes according to the manufacturer's recommendations.

920.7.5.1.2.4 Existing manhole steps or ladders shall be removed by cutting off flush to the manhole wall prior to application of any rehabilitation coatings.

920.7.5.2 INVERT REPAIR

920.7.5.2.1 Invert Repair shall be performed on all inverts with visible damage, where infiltration is present, or when vacuum testing is specified.

920.7.5.2.2 After blocking flow through the manhole and thoroughly cleaning the invert, the quick setting patch material shall be applied to the invert and bench. The material shall be troweled uniformly onto the damaged invert at a minimum thickness of ½-inch at the invert extending out onto the bench of the manhole sufficiently to tie into the structurally enhanced monolithic liner.

920.7.5.2.3 The finish invert surfaces shall be smooth and free of ridges and shall be tapered at the inlets and outlet of the channel for flow.

920.7.5.3 MIXING LINER MATERIALS

920.7.5.3.1 The material shall be mixed per the manufacturer's recommendations at a rate to allow for continuous spraying without interruption until each application is complete.

SECTION 920

SANITARY SEWER MANHOLES

920.7.5.3.2 If ambient temperatures are in excess of 95° F, precautions shall be taken to keep the mix temperature at time of application below 90° F. If necessary, use ice or chilled water during mixing.

920.7.5.4 SPRAYING LINER MATERIALS

920.7.5.4.1 Prior to spraying, the surface shall be clean and free of all foreign material and shall be damp without noticeable free water droplets or running water. Materials shall be applied by spraying a minimum uniform thickness to ensure that all cracks, crevices, and voids are filled and a smooth surface remains after light troweling. The troweling shall compact the material into voids and set the bond.

920.7.5.4.2 Material shall not be applied to frozen surfaces or if freezing is expected to occur within the manhole for 24 hours after application.

920.7.5.4.3 The second application of material shall not begin before the first application has achieved an initial set. The minimum total finished thickness of cementitious material shall not be less than 1/2 inch. The second application shall be trowelled to a smooth finish being careful not to over trowel and to bring additional water to the surface thereby weakening it.

920.7.5.4.4 Ambient manhole conditions are adequate for curing so long as the manhole is covered. It is imperative that the manhole be covered as soon as possible after the application has been completed.

920.7.5.4.5 Contractor shall protect surfaces from contamination of any type between coats and through curing periods.

920.7.5.4.6 Epoxy or polyurethane liner systems shall be applied to a dry film thickness no less than 125 mils excluding any primer coats required by the manufacturer.

920.7.5.4.7 Active flows shall not be introduced through the manhole until the manufacturer's recommended cure time for the product's final coat has been achieved.

920.7.5.5 CONSTRUCTION DEBRIS CONTROL

920.7.5.5.1 The manhole cover shall remain in place except when necessary, .e.g. replacement or adjustment of the ring and cover.

920.7.5.5.2 Where the cover must be removed, the Contractor shall submit a written plan (Debris Control Plan) to control debris to the ENGINEER for approval. The plan shall be a submittal and contain:

920.7.5.5.2.1 Plan for preventing debris from entering the open manhole. Examples are a steel plate covering the open manhole or installation of a sturdy net.

920.7.5.5.2.2 Communication plan. Identify who is responsible for enforcing the Plan to all parties, including sub-contractors, working at the project site.

920.7.5.5.3 No additional payment will be made for the Debris Control Plan.

920.7.6 TESTING AND INSPECTION

920.7.6.1 A visual inspection of the manhole shall be performed to evaluate workmanship of the coating application

920.7.6.2 The cementitious materials used shall be compression strength tested as described in ASTM C39. The Contractor shall provide at least two (2) cylinders of material for testing, each 3 inch diameter x 6 inch long.

920.7.6.3 All manholes shall be tested per Section 920.5 of this Specification.

920.7.6.4 If requested by the Water Authority or Engineer, a Spark test shall be performed to ensure that there is a full monolithic lining and to ensure that there are no pinholes in the coating.

920.7.6.5 If requested by the Water Authority or the Engineer due to concerns regarding delamination or disbanding of the coating resulting from the integrity of the substrate under the coating, the strength of the substrate, or the contamination of substrate, a Pull Test shall be required.

920.8 MEASUREMENT AND PAYMENT

920.8.1 NEW MANHOLES:

920.8.1.1 Type "C" or "E" manholes of 4-foot, 6-foot, and 8-foot diameters shall be measured per each within the following increments of depth: 3 to 6 feet, 6 to 10 feet, and 10 to 14 feet. Manholes greater than 14 feet deep shall be measured and paid per Section 9.8.1.2. Measurements will be made to the nearest foot and will be from the manhole rim elevation to the manhole invert elevation.

920.8.1.2 Payment for manholes 14 feet deep or less will be made on the unit price per manhole diameter per depth increment as specified in the Bid Proposal. Payment for manhole depths which exceed 14 feet will be made on the unit price per manhole diameter per vertical foot. This payment is in addition to the manhole unit price for the portion above the 14 foot depth.

920.8.1.3 Payment for any type diameter or depth of manhole will include excavation, compacted backfilling, benching, cover or cone, leveling bricks, frame and cover, concrete pad or collar, and placement of EMD for sanitary sewers.

SECTION 920

SANITARY SEWER MANHOLES

920.8.2 ELEVATION ADJUSTMENTS:

920.8.2.1 When a new manhole is installed, no measurement or payment will be made for rim elevation adjustments to conform to street surface grades.

920.8.2.2 The following measurements and payments for rim elevation adjustments on existing manholes will be made for indicated conditions:

920.8.2.2.1 Unit price per inch of leveling brick adjustment.

920.8.2.2.2 Unit price per manhole diameter per vertical foot of adjustment to cone and/or barrel.

920.8.2.3 As required, the following items will be included in the unit price per appropriate adjustment: pavement removal and replacement, excavation, compacted backfilling, reinforced concrete collar or pad, leveling bricks, frame, cover, and EMD placement.

920.8.3 EXTERIOR COATING OF MANHOLE:

Exterior waterproof coating for manholes shall be measured and paid for on the unit price per square foot of surface area covered.

920.8.4 INTERIOR COATING OF MANHOLE:

Plastering or epoxy coating for manholes shall be measured and paid for on the unit price per square foot of surface area covered.

920.8.5 ABANDONMENT OF MANHOLES:

Measurement and payment for abandonment of a manhole shall be the unit price per manhole for defined work in Subsection 920.6.

920.8.6 MANHOLE REHABILITATION IN REPLACEMENT WORK: Work under this item shall be measured and paid for by the unit price per manhole for work specified in the Bid Proposal.

920.8.7 TESTING: There will be no payment for required testing of sewer manholes.

SECTION 921

STORM MANHOLES

921.1 GENERAL: This section contains items which are relative to the installation of storm manholes.

921.2 REFERENCES

921.2.1 ASTM

C 43 Standard Terminology of Structural Clay Products

C 139 Standard Specification for Concrete Masonry Units for Construction of Catch Basins and Manholes

C 478 Standard Specification for Precast Reinforced Concrete Manhole Sections

C 497 Standard Test Methods for Concrete Pipe, Manhole Sections, or Tile

C 1557 Standard Test Method for Tensile Strength and Young's Modulus of Fibers

921.2.2 This publication:

SECTION 101 PORTLAND CEMENT CONCRETE

SECTION 102 STEEL REINFORCING

SECTION 105 CONCRETE CURING COMPOUND

SECTION 106 CEMENT MORTAR AND GROUT

SECTION 161 GRAY IRON CASTINGS

921.3 MANHOLE MATERIALS

Storm manhole materials shall be as specified in other sections, as follows:

Portland Cement Concrete	Section 101
Steel Reinforcing	Section 102
Concrete Curing Compound	Section 105
Cement Mortar and Grout	Section 106
Gray Iron Castings	Section 161

921.4 MANHOLE CONSTRUCTION

921.4.1 GENERAL

921.4.1.1 Soil Foundations for manhole base shall be compacted to a density of 95 percent of the maximum density per ASTM D 1557. Compaction limits shall

be one foot beyond the perimeter of the concrete base and shall be a minimum of one foot in depth.

921.4.1.2 Manholes shall be constructed in accordance with the Standard Detail Drawings and as shown on the construction plans. Precast reinforced concrete units, concrete blocks or formed in-place, reinforced concrete may be used to construct manhole.

921.4.1.3 Invert elevation of the pipes entering or exiting the manhole and interior inverts shall not vary more than 0.05 foot from the elevation indicated on the construction plans.

921.4.1.4 All cement used for poured foundations, mortar, fillets, grout, and concrete shelf construction shall be Type II or approved equal.

921.4.1.5 All concrete for formed in place foundations or bases, concrete shelves, and pipe supports shall be 3000 psi compressive strength concrete.

921.4.1.6 Depending on the size of the pipe, connections to existing and new manholes shall be made by either core drilling through the manhole wall, performed for new precast units, or for large-size pipe the manhole wall may be removed by carefully chipping the wall segment which will permit entry of the pipe. In the latter operation, exposed manhole reinforcement should be bend and tied to the reinforcement of the pipe tied to the reinforcement of the pipe collar. If core drilling is not practical, the CONTRACTOR shall request the ENGINEER to authorize the chipping operation. During either operation the CONTRACTOR shall take care to avoid unnecessary damage to the manhole surfaces or walls.

921.4.2 PRECAST CONCRETE MANHOLES:

921.4.2.1 The vertical sections of the manhole may be of different dimensions in order that manholes of various depths can be readily assembled.

921.4.2.2 Concrete, used for precast bases, vertical sections, and eccentric cones, shall be 4000 psi compressive strength concrete.

921.4.2.3 Vertical sections of the manhole shall conform to the requirements of ASTM C 478

SECTION 921

STORM MANHOLES

921.4.2.4 The CONTRACTOR shall submit shop drawings of the precast base and eccentric cone to the ENGINEER for review and approval.

921.4.2.5 Circular precast manhole sections shall be provided with mastic gasket to seal joints between sections and apply non-shrink grout to exterior and interior of joints, or use watertight rubber gaskets. If rubber gaskets are used the manhole sections do not need to be grouted but the manufacturer must stamp the interior of each precast section with the type of gasket used.

921.4.2.6 All lifting holes, except Type "C" manhole covers, and gaps at joints shall be filled with a non-shrink grout.

921.4.2.7 Precast concrete manhole bases may be used when approved by the ENGINEER. If approved, it shall be with the understanding that the CONTRACTOR shall be responsible for placing the bases at the specified elevation, location, and alignment.

921.4.3 FORMED INPLACE REINFORCED CONCRETE MANHOLE:

921.4.3.1 The CONTRACTOR shall submit preconstruction drawings of the proposed manholes to the ENGINEER for review and approval.

921.4.3.2 Concrete used for this type of manhole construction shall be 4000 psi compressive strength concrete.

921.4.3.3 If desired, a precast eccentric cone or a flat cover can be used.

921.4.4 CONCRETE BLOCK MANHOLE:

921.4.4.1 The CONTRACTOR shall submit preconstruction drawings of the proposed manhole to the ENGINEER for review and approval.

921.4.4.2 Concrete masonry units for the construction of this type of manhole shall conform to ASTM C 139 and the Standard Detail Drawings. All blocks shall be mortared into place.

921.4.4.3 Eccentric cone or flat-type cover shall be used.

921.4.5 TEE PIPE MANHOLE:

921.4.5.1 Tee pipe manholes will be used for all 4-foot-diameter mainline pipes and larger. Horizontal section of the tee pipe shall be the same class of pipe as the adjacent sections. The vertical sections shall comply with the requirements set forth in ASTM C 478.

921.4.5.2 Top of the vertical portion of tee pipe unit will extend a minimum of 18-inches above the outside diameter of the horizontal pipe. The 4-foot-diameter vertical section of the tee pipe shall be connected at the longitudinal center point of the horizontal pipe section. The minimum length of horizontal pipe section shall be 8 feet.

921.4.5.3 The CONTRACTOR shall submit to the ENGINEER for review and approval preconstruction shop drawings on the fabrication of the tee pipe section as developed by a precast reinforced concrete pipe manufacturer. Field fabrication of this eccentric pipe unit will not be accepted. Shop drawings for the eccentric cone will also be submitted for review and approval.

921.4.5.4 RAM-NEK, Kent Seal, or approved equal sealants shall be used to seal the joints in the vertical portion of this manhole.

921.4.5.5 All lifting holes, except for Type "C" manhole covers, and gaps at joints shall be filled with a non-shrink grout.

921.4.5.6 Standard Detail Drawings show some of the components of the tee-type pipe manhole.

921.4.6 MANHOLE STEPS:

921.4.6.1 Manhole steps shall be ½" diameter, grade 60, reinforcing rod completely encapsulated in copolymer polypropylene or corrosion resistant rubber compound. Steps shall be designed to be cast in place or hammered into holes in manhole walls.

921.4.6.2 Approved manhole steps of only one manufacturer model shall be used on any specific project and shall not be intermixed with other approved steps. Approved steps must bear the manufacturer name and model on the exposed surface of the step and shall be one of the following products or approved equals: M.A. Industries, Inc. – Model

SECTION 921

STORM MANHOLES

PS-2-PFS H.Bowen Co. – Bowco, Model 81213 or 93813 Delta Pipe Products – WEDG-LOK, Model W-11

921.4.6.3 The minimum width of step tread shall be 11-inches. Steps will be spaced uniformly in each manhole. Spacing may be between 12-inches to 16-inches on center. Lower step will be 12-inches above manhole shelf or top of main. The upper step shall be 6-inches below the top portion of the eccentric cone or 6 inches below the bottom of the flat cover. Also the steps shall be aligned vertically with the opening of the cone or cover.

921.4.6.4 Steps shall be embedded in the manhole wall a minimum of 3-inches and protrude from the manhole interior surface a minimum of 4 ¾-inches.

921.4.6.5 Holes for step installation shall be drilled or precast per manufacturer's recommended size, or of sufficient size to allow for step insertion into the wall. Cast-in-place sockets or tapered holes recommended by the step manufacturer may be used with prior approval of ENGINEER. If the hole has been drilled too large, then the step shall be secured in place by using epoxy grout for the full depth of the drilled hole.

921.4.6.6 Acceptable manhole step installations must be capable of withstanding a 400 pound, horizontal, pull out load applied in accordance with ASTM C 497.

921.4.7 ADJUSTMENT BRICKS:

921.4.7.1 Manhole adjustment bricks shall conform to the requirements for manhole bricks, per ASTM C 32 for Grade MS.

921.4.7.2 Mortar shall be used to lay the bricks, as well as coating the interior and exterior surfaces of the laid brick. Thickness of the mortar coating shall be ½-inch.

921.4.8 MANHOLE FRAME AND COVER: The manhole frame and cover for the storm manholes shall conform to the specifications contained in section 161.

921.5 TESTING OF STORM MANHOLES:

921.5.1 Normally storm manholes need not be tested unless specifically required by the project plans or

supplemental technical specifications. However, if in the opinion of the ENGINEER, the workmanship or materials do not appear to be satisfactory, the ENGINEER may require that any storm manhole be tested in a similar manner as that for a sanitary sewer manhole.

921.6 ABANDONMENT OF MANHOLES

921.6.1 Abandonment of manhole, which is part of a storm drain being abandoned, shall entail the following work and materials:

921.6.2 Manhole will not be removed but will be abandoned in place.

921.6.3 All manhole inlet and outlet lines shall be plugged with a 12-inch –thick concrete or concrete mortar plug.

921.6.4 Salvageable material shall be stockpiled on the job site. The CONTRACTOR shall contact Owner to arrange for a representative to inspect the materials for usability. Salvageable materials shall be transported by the CONTRACTOR to the City Yards. CONTRACTOR will receive a receipt for the turned-in materials. Receipts will be submitted to the ENGINEER prior to final acceptance of the Project. Unusable materials will be disposed of by the CONTRACTOR.

921.6.5 Manhole bottom will be pulverized.

921.6.6 The manhole shall be filled with cement treated base (CTB) material to the bottom elevation of the asphalt base course of the pavement or to the ground surface level.

921.6.7 All labor, materials, and equipment necessary to complete this work shall be furnished by the CONTRACTOR.

921.6.8 For historical information the ENGINEER shall have a survey performed which will locate the abandoned manhole, relative to permanent survey markers.

921.7 STORM MANHOLE REHABILITATION IN REPLACEMENT WORK

921.7.1 The work under this item shall be to replace the existing manhole frame and cover and to place a concrete pad around the existing manhole as required

SECTION 921

STORM MANHOLES

per the construction plans. This work will be done only when an existing manhole is encountered in the normal course of the replacement work that has a light-weight, vented, multi-holed manhole cover.

921.7.2 The work and materials shall include the following:

921.7.2.1 Remove any and all existing brick under frame and replace with new Grade MS brick as necessary to bring new frame and cover up to street grade.

921.7.2.2 Remove and replace existing concrete pad, or construct a new pad.

921.7.2.3 Remove existing steps and replace with new steps or if steps are nonexistent, install new steps. Steps will be installed as per Subsection 921.4.6.

921.7.2.4 Remove and replace pavement.

921.7.2.5 Excavation and compaction of backfill as necessary.

921.7.2.6 All materials, labor, and equipment necessary to do the work under this item shall be furnished by the CONTRACTOR.

921.7.2.7 The work and materials under this item shall be done according to the manner set forth in the Standard Detail Drawings and other section of these specifications.

921.7.3 Salvageable material shall be stockpiled on the job site. The CONTRACTOR shall contact Owner to arrange for a representative to inspect the materials for usability. Salvageable materials shall be transported by the CONTRACTOR to the City Yards. CONTRACTOR will receive a receipt for the turned-in materials. Receipts will be submitted to the ENGINEER prior to final acceptance of the Project. Unusable materials will be disposed of by the CONTRACTOR.

921.8 MEASUREMENT AND PAYMENT

921.8.1 NEW MANHOLES:

921.8.1.1 Type "C", "E", "F", or "G" manholes of 4-foot or 6-foot diameters shall be measured per each within the following increments of

depth: 3 to 6 feet, 6 to 10 feet, and 10 to 14 feet. Manholes which are greater in depth than 1 foot shall be measured by the vertical foot. Measurements will be made to the nearest foot and will be from the manhole rim elevation to the manhole invert elevation.

921.8.1.2 Payment for manholes 14 feet deep or less will be made on the unit price per manhole diameter per depth increment as specified in the Bid Proposal. Payment for manhole depths which exceed 14 feet will be made on the unit price per manhole diameter per vertical foot. This payment is in addition to the manhole unit price for the portion above the 14 foot depth.

921.8.1.3 Type "A" or Tee-type manholes shall be measured and paid for by the methods described in 921.8.1.1 and 921.8.1.2 above. Measurement will be from the invert of the main line to the manhole rim. Payment under this item will include the normal manhole costs described below, as well as any additional pipe costs for the precast tee and for the concrete cradle under the tee.

921.8.1.4 Payment for any type diameter or depth of manhole will include excavation, compacted backfilling, shelving, cover or cone, leveling bricks, frame and cover, and concrete pad or collar.

921.8.2 ELEVATION ADJUSTMENTS:

921.8.2.1 When a new manhole is installed, no measurement or payment will be made for rim elevation adjustments to conform to street surface grades.

921.8.2.2 The following measurements and payments for rim elevation adjustments on existing manholes will be made for indicated conditions:

920.8.2.2.1 Unit price per inch of adjustment ring for adjustment to manhole frame by the addition of adjustment ring.

921.8.2.2.2 Unit price per inch of leveling brick adjustment.

921.8.2.2.3 Unit price per manhole diameter per vertical foot of adjustment to cone and/or barrel.

921.8.2.3 As required, the following items will be included in the unit price per appropriate

SECTION 921

STORM MANHOLES

adjustment: pavement removal and replacement, excavation, compacted backfilling, concrete collar or pad, leveling bricks, adjusting rings, and/or frame and cover.

921.8.3 MANHOLE STEPS:

Unless otherwise shown on the Bid Proposal, the cost of manhole steps shall be incidental to the unit prices for construction of manholes of various types and depths.

921.8.4 ABANDONMENT OF MANHOLES:

Measurement and payment for abandonment of a manhole shall be the unit price per manhole for defined work in Subsection 921.6.

921.8.5 MANHOLE REHABILITATION IN REPLACEMENT WORK:

Work under this item shall be measured and paid for by the unit price per manhole for work specified in the Bid Proposal.

921.8.6 TESTING:

There will be no payment for required testing of storm manholes.

SECTION 925

VACUUM SEWER COLLECTOR, INTERCEPTOR AND FORCE MAIN FACILITIES

925.1 GENERAL:

The construction items specified in this section are common to vacuum sewer facilities.

925.2 REFERENCES

925.2.1 American Society for Testing and Materials (ASTM) Standard Specifications, Latest Edition

C 478 Standard Specification for Precast Reinforced Concrete Manhole Sections

D 1557 Standard Test Methods for Laboratory Compaction Characteristics of Soil Using Modified Effort

D 1784 Standard Specification for Rigid Poly (Vinyl Chloride) (PVC) Compounds and Chlorinated Poly (Vinyl Chloride) (CPVC) Compounds

D 2241 Standard Specification for Poly (Vinyl Chloride) (PVC) Pressure-Rated Pipe (SDR Series)

D 2564 Standard Specification for Solvent Cements for Poly (Vinyl Chloride) (PVC) Plastic Piping Systems

D 2665 Standard Specification for Poly (Vinyl Chloride) (PVC) Plastic Drain, Waste, and Vent Pipe and Fittings

D 2672 Standard Specification for Joints for IPS PVC Pipe Using Solvent Cement

D 3139 Standard Specification for Joints for Plastic Pressure Pipes Using Flexible Elastomeric Seals

925.2.1 This Publication, Latest Edition

SECTION 101	PORTLAND CEMENT CONCRETE
SECTION 102	STEEL REINFORCEMENT
SECTION 105	CONCRETE CURING COMPOUND
SECTION 121	PLASTIC PIPE
SECTION 161	GRAY IRON CASTINGS
SECTION 163	DUCTILE IRON CASTINGS
SECTION 170	ELECTRONIC MARKER DEVICES
SECTION 701	TRENCHING, EXCAVATION AND BACKFILL
SECTION 710	BORING, DRILLING AND JACKING
SECTION 801	INSTALLATION OF WATER TRANSMISSION, COLLECTOR, AND DISTRIBUTION LINES
SECTION 901	SANITARY SEWER COLLECTOR AND INTERCEPTOR FACILITIES
SECTION 920	SANITARY AND STORM SEWER MANHOLES

925.3 MATERIALS

925.3.1 PIPE: All buried vacuum collector lines, branch lines, force mains, vacuum service laterals, and gravity service stubs shall be PVC C900 SDR21 (or Class 200) rated PVC pipe, green in color and conforming to ASTM D

2241, ASTM D 1784 Cell Classification 12454-B. Pipe and appurtenances shall be new and unused.

925.3.2 JOINTS:

All joints shall conform to ASTM D 2672, using solvent cement; or ASTM D 3139 using elastomeric seals. This pipe must be certified by the manufacturer that pipe and seal will operate at 22 inches of mercury vacuum with a maximum loss of 1% of initial vacuum per hour for a 4 hour period.

925.3.3 FITTINGS

925.3.3.1 Fittings shall be Schedule 80 solvent weld drain, waste and vent pipe per ASTM D 2665.

925.3.3.2 Wye fittings and 45-degree ells shall be used throughout; except that a long radius 3" 90-degree ell may be used on the 3" suction line entering the vacuum valve and at the wye connection of the vacuum service lateral to the vacuum main. Tee fittings and short radius ells are prohibited exclusively.

925.3.4 SOLVENT CEMENT:

Shall conform to ASTM D 2564: primer and cement shall not be of same color. Cement shall be gray in color.

925.3.5 MANHOLE SECTIONS:

Manhole sections used for buffer tanks, vacuum isolation valve vaults, pig launchers, and air release valves shall be reinforced precast concrete manhole sections, 48" nominal diameter, conforming to the requirements of ASTM C478 and Section 101 Table 101.C.

925.3.6 MANHOLE JOINTS:

Tongue and groove in precast wall; shall conform to Section 920.4.2 PRECAST CONCRETE MANHOLES.

925.3.7 MANHOLE FRAMES AND COVERS:

Frames and covers for sanitary sewer applications such as manholes used for buffer tanks, vacuum isolation valve boxes or vaults, pig launchers, and air release valves shall conform to this Publication, Section 161 Gray Iron Castings, Section 163 Ductile Iron Castings and the Standard Detail Drawings.

925.3.8 CAST-IN-PLACE CONCRETE:

Cast-in-place concrete used for footings, anti-flotation collars, grade-level pads, mass concrete for buffer tanks, and other installations not otherwise addressed shall be air-entrained concrete in accordance with Sections 101, 102, and 105 of this Publication.

925.3.9 VALVES: Valves used for pig launchers and vacuum isolation valves shall be mechanical joint gate valves conforming to Sections 801.3.3 of this Publication. Vacuum isolation valves shall be equipped with five-sided nuts per Standard Detail Drawing 2169. Only valves specified on the Water Approved Product List shall be used.

SECTION 925

VACUUM SEWER COLLECTOR, INTERCEPTOR AND FORCE MAIN FACILITIES

925.3.10 AIR RELEASE VALVES:

Only air release valves specified on the Water Authority Approved Product List shall be used.

925.3.11 VACUUM VALVES AND APPURTENANCES:

Vacuum valves shall be those listed on the Water Authority Approved Product List. Furnish all mechanical appurtenances required for a complete installation per manufacturer specifications. Vacuum valves and appurtenances are to be delivered to the Water Authority's Water Reclamation warehouse, unloaded, and stored as directed by the ENGINEER in complete packages.

925.3.12 VACUUM VALVE PITS

925.3.12.1 Only deep Vacuum valve pits listed on the Water Authority Approved Product List shall be installed.

925.3.12.2 The deep valve pit shall have a sump 54 inches in depth.

925.3.13 STAINLESS STEEL:

Stainless steel for brackets and fasteners shall be Type 316.

925.4 SUBMITTALS

925.4.1 The following shall be submitted for the ENGINEER'S approval prior to incorporation in the work of the corresponding item:

- a) Concrete Mix Design(s)
- b) Material and method of sealing pipe penetrations in buffer tank walls
- c) Pipe certification for vacuum service

925.4.2 The OWNER/ENGINEER will be supplied with a certificate of compliance for each item or type of material required in the system, as to that item meeting the specifications and/or the reference specifications before that item is installed.

925.4.3 The following records shall be maintained by the CONTRACTOR, shall be kept at all times for inspection by the ENGINEER, and shall be submitted to the ENGINEER upon request or as provided in these Specifications.

925.4.3.1 Vacuum tests shall be performed daily or as otherwise stipulated. These tests shall be recorded on charts provided by the OWNER or in hard-board notebooks as stipulated herein depending on the type of test.

925.4.3.2 Record Drawings markups and related survey notebooks shall be kept current by the CONTRACTOR to record work performed and to reflect any and all revisions made from the original construction drawings.

925.5 INSTALLATION

925.5.1 GENERAL

925.5.1.1 Handle pipe and appurtenances in such a manner as to insure delivery to the trench in sound, undamaged condition. Particular care shall be taken to prevent damage to any coating.

925.5.1.2 Prior to installation, store plastic pipe and protect from prolonged periods of sunlight per Section 121.

925.5.1.3 The interior of the pipe, pits, and all appurtenances shall be thoroughly cleaned of foreign material before being lowered into the trench and shall be kept clean during construction operations.

925.5.1.4 Install a plug in the new system at any point of connection to an existing system. The CONTRACTOR shall not flush or otherwise discharge any flow into an existing system unless approved in writing by the ENGINEER and Water Authority.

925.5.1.4.1 The plug shall remain in place until the ENGINEER or Water Authority authorizes its removal in writing. Under all circumstances, the CONTRACTOR shall be required to remove all plugs prior to acceptance of the work.

925.5.1.4.2 The CONTRACTOR shall certify in writing the completion of the plug removal task. The certification shall include the locations of removed plugs and corresponding date of removal. The Water Authority assumes no liability for damages caused by plugs inadvertently left in the line by the Contractor.

925.5.1.5 Perform trenching, backfilling, and compaction in accordance with Section 701.

925.5.2 PIPE INSTALLATION

925.5.2.1 All vacuum sewers shall be laid to line and grade as shown on the construction drawings. All pipe which has been designed to slope downward shall slope uniformly downward, with a tolerance of no more than 0.01 feet per 20 feet of line. Abrupt sags or bellies will not be permitted. The elevation at 100 foot intervals of pipe shall be recorded by the CONTRACTOR in bound field books which shall be submitted to the ENGINEER.

925.5.2.2 All sanitary sewer force mains shall be laid to line and grade as shown on the drawings. Particular care shall be taken to avoid crests in the profile at locations other than those shown on the drawings. Elevations shall be recorded by the CONTRACTOR at 100-foot intervals, and at each change in grade, in bound field books which shall be submitted to the ENGINEER.

925.5.2.3 Handle and install pipe and fittings in accordance with manufacturer's recommendations.

SECTION 925

VACUUM SEWER COLLECTOR, INTERCEPTOR AND FORCE MAIN FACILITIES

925.5.2.4 Prevent entrance of dirt or foreign matter or damage to pipe lining or coating. Plug the pipe any time work is stopped.

925.5.2.5 No defective pieces are permitted. Defective pieces discovered after use will be removed and replaced with a sound piece.

925.5.2.6 Place bedding, embedment and backfill in accordance with Section 701 unless otherwise indicated on the construction plans. The bedding of the trench shall be graded and prepared to provide a firm and uniform bearing throughout the entire length of the pipe. Suitable excavation shall be made to receive the bell of the pipe and the joint shall not bear upon the bottom of the trench. All adjustments to the line and grade shall be made by scraping away or filling in with pipe zone material under the body of the pipe, but not by wedging or blocking. When connections are to be made to any existing pipe, valve pit, or any other improvement, where the actual elevation or position cannot be determined without excavation, excavate and expose the existing improvement before laying the connecting pipe or conduit. Should existing underground improvements be expected to conflict with the line or grade established for the new sewer line, the ENGINEER shall request the CONTRACTOR to excavate as necessary to expose such potentially conflicting underground improvements prior to laying the new pipe. Any adjustment in line or grade which may be necessary to accomplish the intent of the plans shall be made, and the CONTRACTOR will be paid for any additional work resulting from such change in line or grade in the manner provided for in the GENERAL CONDITIONS.

925.5.2.7 Lay pipe upgrade in a continuous operation from structure to structure, with the socket ends of the pipe upgrade unless otherwise permitted by the ENGINEER.

925.5.2.8 Sanitary sewer mains shall not be constructed under walkways, sidewalks, curbs and gutters, drive pads, or similar concrete structures by tunneling underneath them. The CONTRACTOR will remove the section of the concrete structure to the nearest full expansion joint or edge.

925.5.2.9 Place and hand-tamp fill to 95% of maximum dry density per ASTM D 1557, in entire space between the pipe or fitting and the trench walls.

925.5.2.10 Prior to completely backfilling the sewer excavation, install a green metalized detectable warning tape 12" to 18" below finished grade. The tape shall be detectable with a standard metal pipe locator. The tape shall be a minimum of 2 inches wide and inscribed at 10-foot intervals with the words, "CAUTION BURIED SEWER LINE BELOW". The tape shall be constructed of material that is impervious to alkalis, acids, chemical reagents, and solvents found in the soils.

925.5.2.11 Electronic marker devices shall be installed in the locations specified in Section 170 at the manufacturer's recommended bury depth.

925.5.2.12 Provide pipe through casing with support skids as shown on the construction drawings and/or Standard Detail Drawing 2180 and 2380. Alternate support methods may be acceptable upon ENGINEER'S review and approval.

925.5.2.13 Before the work will be accepted, coordinates accurate to within 0.3 feet horizontally and 0.1 feet vertically shall be provided on the Record Drawings for all fitting locations, runs of mainline at a maximum of 100 foot intervals, and all changes in pipe grade. Coordinates shall be determined by a field survey by a Professional Surveyor licensed in the state of New Mexico. Use the NAD 1983 NM STATE PLANE CENTRAL ZONE for x and y coordinates and NAVD 1988 for z coordinate. A report certified by the licensed Professional Surveyor shall be referenced on the Record Drawings.

925.5.2.14 Trace wire shall be installed per Section 901 on all vacuum sewer collectors, interceptors, force mains, and any other portion of the sanitary sewer system considered public infrastructure that will be owned and maintained by the Water Authority.

925.5.3 ISOLATION VALVE

925.5.3.1 Isolation valves and valve box shall be installed per Standard Detail Drawing 2170.

925.5.3.2 Before the work will be accepted, vacuum isolation valve coordinates, accurate to within 0.3 feet, shall be provided on the Record Drawings. Coordinates shall be determined by a field survey by a Professional Surveyor licensed in the state of New Mexico. Use the NAD 1983 NM STATE PLANE CENTRAL ZONE for x and y coordinates and NAVD 1988 for z coordinate. A report certified by the licensed Professional Surveyor shall be referenced on the Record Drawings.

925.5.4 VACUUM VALVE PIT INSTALLATION

925.5.4.1 Install complete vacuum valve pits in accordance with manufacturer instructions and Standard Detail Drawing 2165. Perform pressure testing on each valve pit assembly per the manufacturer instructions.

925.5.4.2 Stub-outs for the gravity service line from the collection sump should be 4" diameter, extended to the property line unless otherwise indicated. Each stub-out should have a stop glued in place 4" to 6" from the end inserted into the tank, to prevent it being pushed too far into the collection sump. A solvent welded 4" cap should be fitted and glued to each stub-out to prevent rocks and groundwater entering the sump prior to connection of the house gravity line. Expandable test plugs or rubber caps are not acceptable as temporary covers for gravity stub-outs.

SECTION 925

VACUUM SEWER COLLECTOR, INTERCEPTOR AND FORCE MAIN FACILITIES

925.5.4.3 Before the work will be accepted, vacuum valve pit coordinates, accurate to within 0.3 feet, shall be provided on the Record Drawings. Coordinates shall be determined by a field survey by a Professional Surveyor licensed in the state of New Mexico. Use the NAD 1983 NM STATE PLANE CENTRAL ZONE for x and y coordinates and NAVD 1988 for z coordinate. A report certified by the licensed Professional Surveyor shall be referenced on the Record Drawings.

925.5.5 SINGLE OR DOUBLE BUFFER TANK INSTALLATION

925.5.5.1 Install single or double buffer tank as shown on the construction drawings and Standard Detail Drawing 2167 (single) or 2168 (double).

925.5.5.2 All pipe penetrations through the buffer tank walls shall be water tight. Submit manufacturer's literature on material and technique for sealing to the ENGINEER.

925.5.5.3 Install suction and sensor pipes as shown on the Standard Detail Drawings. Attach these lines to the buffer tank side walls using Type 304 stainless steel brackets and fasteners. The 3" service lateral is to be stubbed into the buffer tank and capped or otherwise sealed until the vacuum valve is installed.

925.5.5.4 Install breather pipe through buffer tank wall as shown on Standard Detail Drawing 2167 (single) or 2168 (double). This line is to be capped or otherwise sealed to prevent any infiltration of water during construction. It shall be tested in accordance with Breather Test Procedure, Paragraph 925.8.

925.5.5.5 Buffer tanks shall be tested after assembly. The entire buffer tank shall be tested as follows:

925.5.5.5.1 Stub-outs, manhole boots, and pipe plugs shall be permanently secured to prevent movement while the vacuum is drawn.

925.5.5.5.2 Installation and operation of vacuum equipment and indicating devices shall be in accordance with manufacturer's recommendations.

925.5.5.5.3 Using Water Authority-furnished vacuum pump and gage, establish a measured vacuum of 10 inches of mercury in the buffer tank then record the time for the vacuum to drop to nine inches of mercury.

925.5.5.5.4 The maximum allowable leakage rate for a four-foot diameter manhole shall be in accordance with the following:

Min. Elapsed Time For a Pressure
Manhole Depth Change of 1" Hg

10' or less	60 seconds
> 10' but < 15'	75 seconds
≥ 15' but < 25'	90 seconds

925.5.5.5.5 If the buffer tank fails the test, necessary repairs shall be made and the vacuum test and repairs shall be repeated until the tank passes the test. The extent and type of repairs that may be allowed shall be subject to the approval of the ENGINEER. Leaks shall be repaired on the outside of the manhole unless otherwise approved by the ENGINEER.

925.5.5.5.6 If the joint mastic in a buffer tank is pulled out during the vacuum test, the manhole shall be disassembled and the mastic replaced.

925.5.5.5.7 Record test results on a calibrated chart recorder as described in Section 925.6, Field Quality Control.

925.5.5.6 Before the work will be accepted, buffer tank coordinates, accurate to within 0.3 feet, shall be provided on the Record Drawings. Coordinates shall be determined by a field survey by a Professional Surveyor licensed in the state of New Mexico. Use the NAD 1983 NM STATE PLANE CENTRAL ZONE for x and y coordinates and NAVD 1988 for z coordinate. A report certified by the licensed Professional Surveyor shall be referenced on the Record Drawings.

925.5.6 INSTALLATION OF CASING FOR SANITARY SEWER VACUUM MAIN OR FORCE MAIN: Casing for sanitary sewer vacuum main or force main shall be per construction drawings, Standard Detail Drawing 2180, Standard Detail Drawing 2380, and per Section 710 of this publication.

925.5.7 AIR RELEASE VALVE INSTALLATION:

925.5.7.1 Air release valves shall be installed per Standard Detail Drawing 2160.

925.5.7.2 Before the work will be accepted, air release valve coordinates, accurate to within 0.3 feet shall be provided on the Record Drawings. Coordinates shall be determined by a field survey by a Professional Surveyor licensed in the state of New Mexico. Use the NAD 1983 NM STATE PLANE CENTRAL ZONE for x and y coordinates and NAVD 1988 for z coordinate. A report certified by the licensed Professional Surveyor shall be referenced on the Record Drawings.

925.6 FIELD QUALITY CONTROL

925.6.1 Provide daily testing of all sewer mains and lateral connections that are laid. Plug all open connections with rubber stoppers or temporary caps, fitted to the pipe by "no-hub" couplings. Using Water Authority-furnished vacuum pump and chart recorder, apply a vacuum to 22 inches of mercury to the pipes with pump running continuously for 15 minutes to allow vacuum to stabilize before proceeding with test. There shall be no loss in excess of 1% of initial vacuum per hour for a two hour test

SECTION 925

VACUUM SEWER COLLECTOR, INTERCEPTOR AND FORCE MAIN FACILITIES

period. As pipe is laid the new section shall be tested in addition to the previously laid pipe on that main.

925.6.2 Leave uncovered the sewer main pipe joints until after the daily vacuum test is complete so that any leaks can be easily located and repaired. Exposed joints shall be adequately restrained.

925.6.3 Two-hour Vacuum Line Test Modification Provision: If the CONTRACTOR succeeds in meeting the daily 2-hour test for seven consecutive working days or two thousand feet of pipe, the ENGINEER may amend the procedure to allow the trench to be covered as work progresses rather than the trench being kept open all day as is the norm with the daily 2-hour test. Should a line fail the vacuum test while utilizing this test modification, the CONTRACTOR shall take whatever action is necessary at his cost to pass the test including the excavation of the trench, leak detection and line repair, and additional cleanup as required by the ENGINEER. After the failure, the CONTRACTOR must re-qualify as specified above. Note this test modification is optional, and as such, the CONTRACTOR assumes all liability in its use. Allowance of this modification by the ENGINEER is not considered acceptance of the sewer line or ability to withstand test vacuum pressures.

925.6.4 Installation and operation of vacuum equipment and indicating devices shall be in accordance with manufacturer's recommendations.

925.6.5 Required Final Acceptance Testing on complete system: Provide 48-hour notice (minimum) to ENGINEER prior to test. Ensure all isolation valves are open prior to beginning of test. Subject the entire sewerage system to a vacuum of 22 inches of mercury, and allow the system to stabilize for 15 minutes before proceeding with test. There shall be no loss greater than 1% of initial vacuum per hour over a four hour test period.

925.6.6 All daily testing and Final Acceptance Test shall be recorded on vacuum charts to be provided by the ENGINEER. These charts will not be considered valid unless witnessed by ENGINEER on test equipment at beginning and end of vacuum test period.

925.6.7 The ENGINEER will sign and date charts to verify witness of tests. This signature does not indicate acceptance of the system.

925.7 LINE FLUSHING

925.7.1 After acceptance testing, flush lines to remove debris and foreign materials that accumulated in the lines during construction.

925.7.1.1 Suggested procedure (This procedure requires the use of vacuum valves. Coordination of installation by the Water Authority is the responsibility of the CONTRACTOR):

925.7.1.1.1 Place system under vacuum to 22 inches mercury.

925.7.1.1.2 Add water to valve pits at extreme ends of system and cause vacuum valves to operate and draw water into piping system.

925.7.1.1.3 Utilize system vacuum to transport the water and debris to collection point. Continue procedure until water entering at collection point is free of contamination or debris. If vacuum station collection tank is used as collection point, monitor volume of liquid in tank and pump out as necessary by means other than system sewage pumps. After completion of flushing, clean collection tank of all collected debris.

925.7.1.1.4 Restore vacuum collection tank and collection system to permanent configuration and make ready to place into operation.

925.7.1.2 Alternate flushing procedures are subject to ENGINEER'S review and approval.

925.8 BREATHER TESTING

925.8.1 After entire breather assembly is complete from the above ground flexible extension to the interior of the valve vault or buffer chamber, it shall be pressure tested as follows:

925.8.1.1 Fabricate a test pipe using ¾-inch PVC materials or approved equal; one end to be ¾-inch male pipe thread, the opposite end to terminate with a 1/8-inch tubing connection.

925.8.1.2 Remove breather dome and install the test pipe in its place. Pressurize the breather assembly to a minimum 40-inch water gage as measured with a magnehelic gauge. The assembly shall remain at a constant pressure with no detectable leaks for a minimum of one minute in the presence of the on-site field inspector. A dated record of all testing of breather domes shall be maintained in a bound notebook, which shall be turned over to the ENGINEER upon completion of all work.

925.9 MEASUREMENT AND PAYMENT

925.9.1 SANITARY SEWER FORCE MAIN WITH BEDDING

925.9.1.1 Measurement shall be per linear foot measured horizontally along the centerline of pipeline and fittings from the collection/lift station interface to the point of discharge as shown on the construction drawings. No deduction from the total will be made for intermittent installations such as isolation valves, pig launchers, and associated manholes.

925.9.1.2 Payment will be in accordance with the unit price per linear foot per size and material as defined in the Bid Proposal, and shall include: unclassified excavation in

SECTION 925

VACUUM SEWER COLLECTOR, INTERCEPTOR AND FORCE MAIN FACILITIES

open trench, backfilling, and compaction for all trench zones; hand digging; removing and replacing surface obstructions; discovery and protection of subsurface obstructions; shoring and bracing; hauling excavated material; restoration of disturbed areas not included in other pay items; all fittings, concrete thrust blocking or restrained joints; installation of electronic marking devices and green metalized warning tape; preparation of pipe subgrade; furnishing and placing granular bedding; trench dewatering; temporary connections; jointing and coupling materials; furnishing and installing pipe in open trench; flushing and cleaning the pipe; air and hydrostatic pressure testing; and all other labor, material, and equipment incidental thereto.

925.9.2 SANITARY SEWER FORCE MAIN PIG LAUNCHER

925.9.2.1 Measurement of installed pig launcher shall be per each unit installed as shown on the construction drawings.

925.9.2.2 Payment for the pig launchers will be in accordance with the unit price per each as defined in the Bid Proposal, and shall include: furnishing and installing all fittings, flanges, restraining glands, and harnesses; drilling and preparing precast manhole section for slotted opening including gaskets, sealants, and grout; furnishing and installing resilient seat gate valves; preparing and installing cast-in-place concrete footer and pad on finished ground including trenching, backfilling, and compaction, furnishing and installing reinforcing steel; furnishing and installing precast manhole sections including trenching, backfilling, and compaction, gaskets, electronic marker device, frame and cover; furnishing and installing gravel bed for floor of manhole; and all other labor, material, and equipment incidental thereto.

925.9.3 BORE AND JACK, CASING FOR SANITARY SEWER VACUUM MAIN OR FORCE MAIN

925.9.3.1 Measurement shall be per linear foot, measured horizontally along the centerline of the encasement pipe actually installed for the work accomplished as shown on the Standard Detail Drawings and on the construction drawings.

925.9.3.2 Payment will be in accordance with the unit price per linear foot as defined in the Bid Proposal, and shall include: trenching, unclassified excavation, backfilling, and compaction; furnishing and installing bored steel casing, casing insulators, and casing end seals; repair and replacement of existing roadway, bridge abutments, utilities, or any other structures damaged during boring and jacking operations; removal and disposal of waste material; providing grout for backfilling; inspections or permits; and all other labor, material, and equipment incidental thereto; except that the carrier pipe will be paid for under the appropriate bid item for vacuum main or force main.

925.9.4 SANITARY SEWER AIR RELEASE VALVE

925.9.4.1 Measurement shall be per each air release valve installed as shown on the Standard Detail Drawings and the construction drawings.

925.9.4.2 Payment will be in accordance with the unit price per each as defined in the Bid Proposal, and shall include: furnishing and installing air release valve with all necessary fittings and appurtenances; drilling and preparing precast manhole section for slotted opening including gaskets, sealants, and grout; preparing and installing cast-in-place concrete footer and pad on finished ground including trenching, backfilling, and compaction, furnishing and installing reinforcing steel; furnishing and installing precast manhole sections including trenching, backfilling, and compaction, gaskets, electronic marker device, frame, and cover; furnishing and installing gravel bed for floor of manhole; and all other labor, material, and equipment incidental thereto.

925.9.5 VACUUM SEWER ISOLATION VALVE AND VALVE BOX

925.9.5.1 Measurement shall be per each vacuum sewer isolation valve and valve box installed as shown on the construction drawings and the Standard Detail Drawing.

925.9.5.2 Payment will be in accordance with the unit price per each as defined in the Bid Proposal, and shall include: furnishing and installing resilient seat gate valve with all necessary fittings and appurtenances; furnishing the Water Authority with one 6-foot long T-handle extension bar for every five valves installed; furnishing, drilling, and preparing precast manhole section for slotted opening including gaskets, sealants, and grout; preparing and installing cast-in-place concrete footer and pad on finished ground including trenching, backfilling, and compaction; furnishing and installing reinforcing steel; furnishing and installing precast manhole sections including trenching, backfilling, and compaction, gaskets, electronic marker device, frame, and cover; furnishing and installing gravel bed for floor of manhole; and all other labor, material, and equipment incidental thereto.

925.9.6 VACUUM SEWER BUFFER TANK

925.9.6.1 Measurement shall be per each installed buffer tank (single or double per the respective bid item) as shown on the construction drawings and the Standard Detail Drawings.

925.9.6.2 Payment will be in accordance with the unit price per each as defined in the Bid Proposal, and shall include: furnishing and installing all necessary equipment, including pipe and breather connections, breather vent piping and flexible breather pipe assembly; preparing and installing cast-in-place concrete footer and pad on finished ground including trenching, backfilling, and compaction, furnishing and installing reinforcing steel; furnishing and installing precast manhole sections including trenching,

SECTION 925

VACUUM SEWER COLLECTOR, INTERCEPTOR AND FORCE MAIN FACILITIES

backfilling, and compaction, gaskets, frame, and cover; furnishing and installing all fittings, pipe, and all appurtenances; connection of the new or existing sanitary sewer gravity lines including drilling precast manhole sections, gaskets, sealants, and grout; furnishing and installing concrete grout for shelf; air and vacuum testing as required; and all other labor, material, and equipment incidental thereto.

925.9.7 VACUUM VALVE PIT

925.9.7.1 Measurement shall be per each deep vacuum pit installed as shown on the construction drawings and the Standard Detail Drawings.

925.9.7.2 Payment will be in accordance with the unit price per each as defined in the Bid Proposal, and shall include: furnishing and installing all necessary equipment including unclassified excavation in open trench, backfilling, and compaction for all trench zones; hand digging; removing and replacing surface obstructions including fencing, landscaping, and all other obstructions; discovery and protection of subsurface obstructions; shoring and bracing; hauling excavated material, restoration of disturbed areas not included in other pay items; all fittings and concrete anti-flotation collar; installation of flexible breather pipe assembly and all appurtenances; stub-outs for connection of gravity and vacuum lines; air, vacuum, and all other testing as required; and all other labor, material, and equipment incidental thereto.

925.9.8 VACUUM COLLECTION LINES AND VACUUM SERVICE LATERALS

925.9.8.1 Measurement of vacuum collection lines and vacuum service laterals shall be per linear foot measured horizontally along the centerline of pipeline as shown on the drawings.

925.9.8.2 Payment will be in accordance with the unit price per linear foot per size and material as defined in the Bid Proposal, and shall include: unclassified excavation in open trench, backfilling, and compaction for all trench zones; hand digging; removing and replacing surface obstructions; discovery and protection of subsurface obstructions; shoring and bracing; hauling excavated material, restoration of disturbed areas not included in other pay items; all fittings, concrete thrust blocking or restrained joints; preparation of pipe subgrade; furnishing and placing granular bedding; trench dewatering; temporary connections; jointing and coupling materials; furnishing and installing pipe in open trench; flushing and cleaning the pipe; field quality control testing including daily vacuum testing of lines using Water Authority furnished trailer mounted vacuum pump, breather testing, and all other testing required; making all required submittals; and all other labor, material, and equipment incidental thereto.

925.9.9 VACUUM VALVES AND APPURTENANCES:

Measured and paid for per each as a separate pay item as included in the associated Vacuum Pit or Buffer Tank as specified and provided in the Bid Proposal.

925.9.10 TRACE WIRE: All work associated with the installation of the trace wire and system shall be considered incidental to the installation cost of the pipeline being traced.

Volcano Cliffs Subdivision

UNIT 3 OCTOBER, 1965

BERNALILLO COUNTY, NEW MEXICO

S-1272-3

FEB 15 1966
C6
107
Jane Springer
Deputy Clerk

Whiteman Engineering Co.
1821A San Mateo N.E.
Albuquerque, New Mexico

DEDICATION

The foregoing subdivision of that certain tract of land, situate within Section 27, and 26, T. 11 N., R. 2 E., N.M.P.M.; Bernalillo County, New Mexico and being more particularly described by survey as follows:

Beginning at the S.E. corner of the tract herein described, whence the 1/4 corner common to Sections 26 and 27, T. 11 N., R. 2 E., thence S. 89°-57'-45" E. 1349.44 feet; thence from said point of beginning N. 00°-02'-15" W. 1026.00 feet to a point; thence S. 89°-57'-45" E. 1841.55 feet to a point; thence along the curve to the left 224.36 feet (curve data is delta = 45°-06', R = 285.28 feet); thence N. 44°-51'-15" E. 34.03 feet to a point; thence N. 00°-02'-15" W. 804.17 feet to a point; thence S. 89°-57'-45" E. 1229.35 feet to a point; thence N. 78°-09'-42" W. 1882.04 feet to the N.E. corner of the Easterly E.O.W. line of Atresco Road N.W.; thence along a curve to the right 662.56 feet (curve data is delta = 37°-40'-09", R = 1007.93 feet); thence S. 11°-43'-24" E. 605.89 feet to a point; thence S. 78°-16'-36" W. 468.38 feet to a point; thence S. 49°-37'-36" W. 307.36 feet to a point; thence S. 52°-22'-24" E. 411.41 feet to a point; thence S. 40°-22'-24" E. 709.8 feet to a point; thence S. 28°-23'-24" E. 508.15 feet to a point; thence N. 61°-16'-36" E. 208.30 feet to a point; thence S. 28°-23'-24" E. 365.30 feet to the S.W. corner; thence N. 61°-22'-51" E. 94.03 feet to a point on curve; thence along the curve to the right 597.14 feet (curve data is delta = 13°-24'-54", R = 1197.05 feet); thence N. 89°-57'-45" E. 1502.80 feet to a point; thence S. 00°-02'-15" W. 106.00 feet to a point, said point being the 1/4 corner common to Sections 26 and 27, T. 11 N., R. 2 E., N.M.P.M.; thence N. 89°-57'-45" E. 1349.44 feet to the S.E. corner and point of beginning, containing 170.10 acres more or less. There is excepted therefrom County Courthouse, May 5, 1964, containing 39.550 acres more or less.

Surveyed and subdivided as the same appears hereon, comprising Tract A; lots 1 thru 12, block 1; lots 1 thru 10, block 2; lots 1 thru 10, block 3; lots 1 thru 10, block 4; lots 1 thru 13, block 5; lots 1 thru 10, block 6; lots 1 thru 16, block 7; lots 1 thru 7, block 8; lots 1 thru 14, block 9; lots 1 thru 17, block 10; lots 1 thru 3, block 11; lots 1 thru 8, block 12; lots 1 thru 11, block 13 and the several public thoroughfares, drainage easements and alleys together with the easements for public utilities. That the owners of the property do hereby dedicate electric power and telephone line easements on the rear seven (7) feet of each lot and also easements as shown on this plat, including easements for overhead, underground and buried service wires and including the right of ingress, egress and the rights to trim or remove interfering trees. All in the Volcano Cliffs Subdivision, Unit 3, a subdivision to the City of Albuquerque, New Mexico.

First Title Guarantee & Trust Co.,
As Trustee
By: Paul V. Crowley
President, Paul Crowley
Attest: Helen Cecil
Asst. Secretary, Helen Cecil

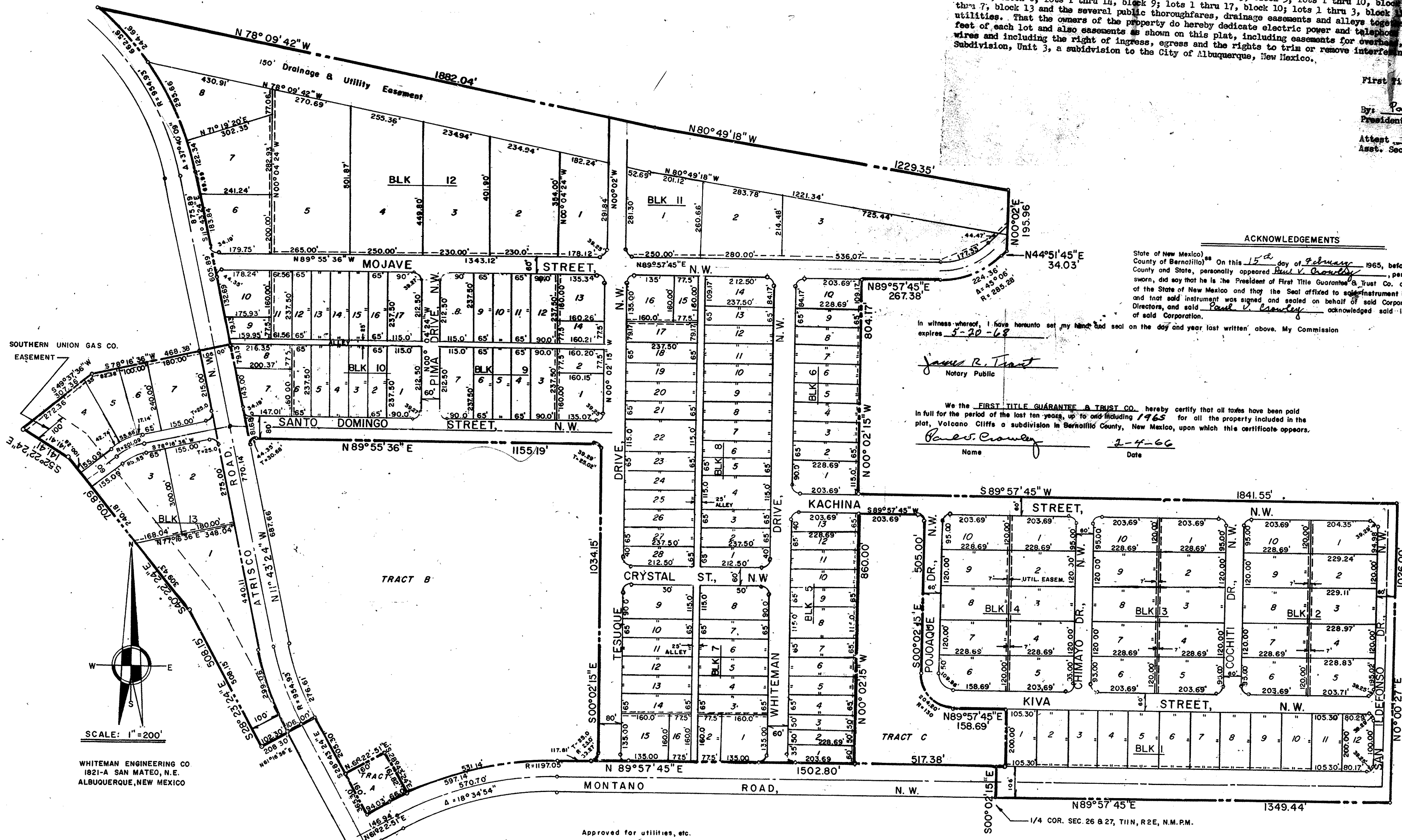

ACKNOWLEDGEMENTS

State of New Mexico) On this 15th day of February, 1965, before me, a Notary Public in and for said County and State, personally appeared Paul V. Crowley, personally known to me, who being duly sworn, did say that he is the President of First Title Guarantee & Trust Co., a Corporation organized under the Laws of the State of New Mexico and that the Seal affixed to said instrument is the Corporate Seal of said Corporation and that said instrument was signed and sealed on behalf of said Corporation, by authority of its Board of Directors, and said Paul V. Crowley acknowledged said instrument to be the free act and deed of said Corporation.

In witness whereof, I have hereunto set my hand and seal on the day and year last written above. My Commission expires 5-20-68

James R. Trent
Notary Public

We the FIRST TITLE GUARANTEE & TRUST CO. hereby certify that all taxes have been paid in full for the period of the last ten years, up to and including 1965 for all the property included in the plat, Volcano Cliffs a subdivision in Bernalillo County, New Mexico, upon which this certificate appears.

Name: Paul V. Crowley Date: 2-4-66

I, Ida V. Malone, City Clerk of the City of Albuquerque, New Mexico, do hereby certify that the plat upon which this certificate appears was approved for filing by the City Commission of said City at its meeting held on the 3rd day of February, 1965.

City Clerk

Notes: All curves not marked are 90° and are 39.27' in length

Notes: 7' Utility easements on rear lot lines
5' Utility easements on side lot lines
Another easements are 30' long and 5' on each side of property line.

I Douglas E. Whiteman, P. E. & L.S. No. 1544, do hereby certify that the above subdivision was prepared under my supervision from actual field notes and is true and correct to the best of my knowledge and belief.

Douglas E. Whiteman

Approved for utilities, etc.

E.P. Hanley 11-24-65
Public Service Co. Date

F.D. Smith 11-24-65
Mt. Sta. Tel. & Tel. Co. Date

Charles R. Stuedel 11-22-65
Southern Union Gas Co. Date

Edwin J. Clark 2-4-66
City Traffic Engineer Date

William D. Jones 2-4-66
City Engineer Date

Robert R. Bursan 2-4-66
Director of Parks & Recreation Date

Paul V. Crowley
Chairman, City Planning Commission Date

L. Bernice Jones by H.L. Crowther 2-3-66
Exec. Secretary City Planning Commission Date

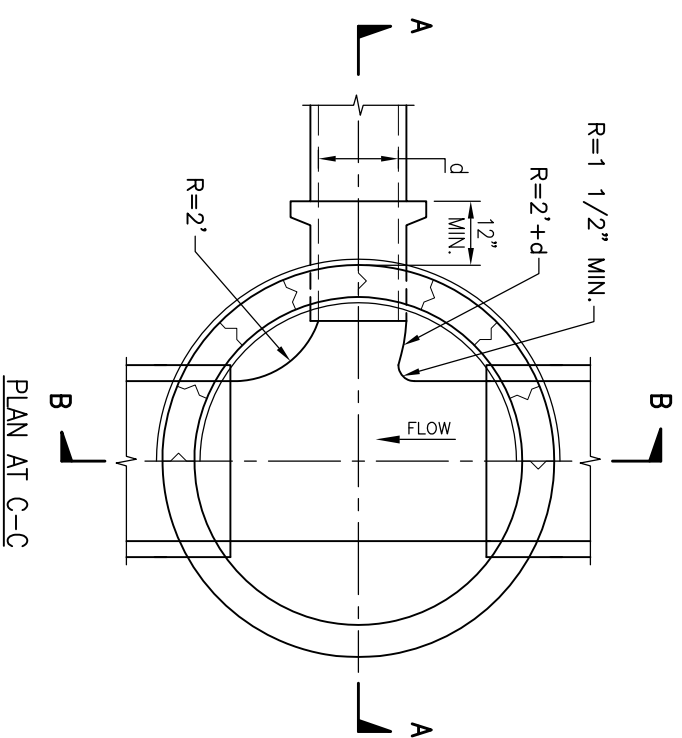

PLAN AT C-C

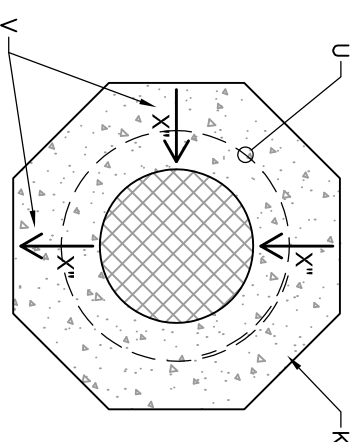

PLAN AT D-D

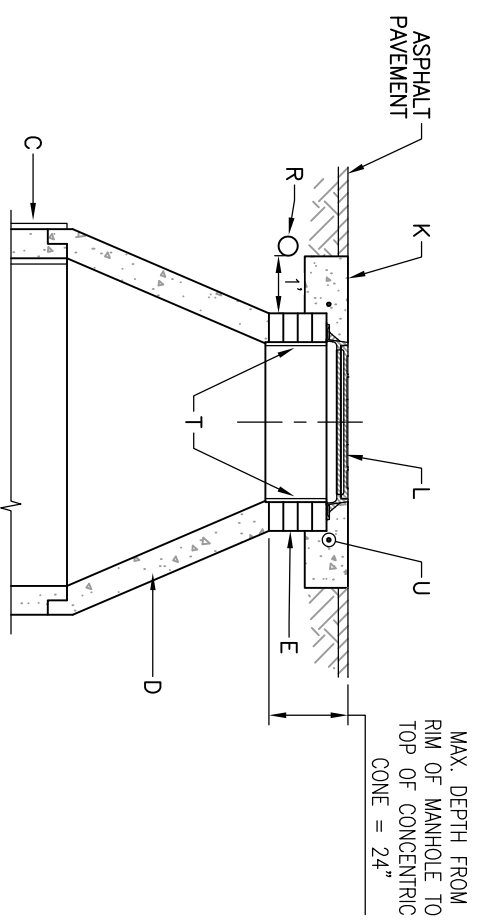

CROSS SECTION A-A

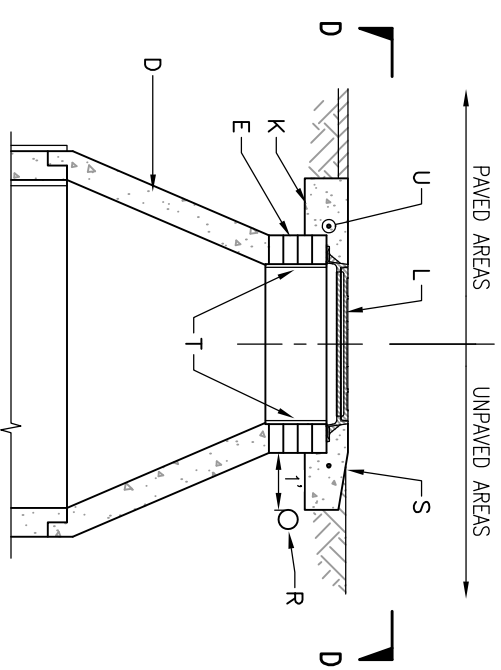

CROSS SECTION B-B

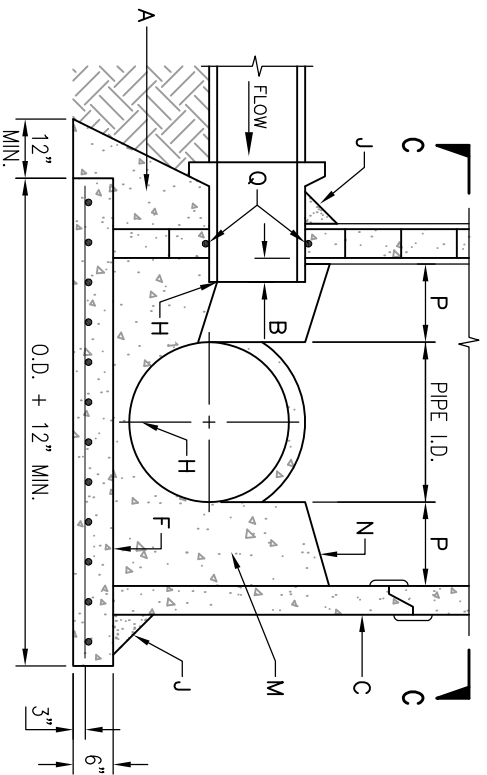

CROSS SECTION A-A

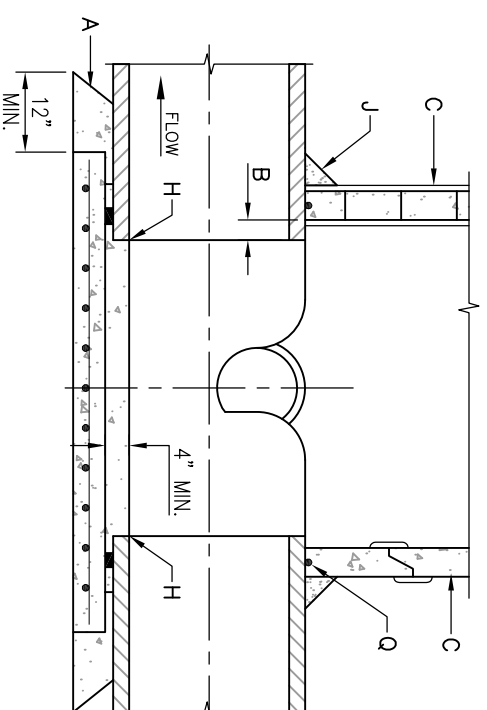

CROSS SECTION B-B

- GENERAL NOTES**
1. USE TYPE "E" MANHOLE FOR DEPTHS OF ≥6' MEASURED FROM INVERT TO RIM.
 2. CONTRACTOR HAS OPTION TO CONSTRUCT TYPE "C" MANHOLE IN LIEU OF TYPE "E" MANHOLE FOR DEPTHS ≥6'.
 3. MANHOLES >18' IN DEPTH SHALL BE CONSTRUCTED OF PRECAST CONCRETE SECTIONS ONLY.
 4. DESIGN APPLIES TO 4' TO 6' I.D. MANHOLES.
 5. COMPACT ALL BACKFILL AROUND MANHOLE TO 95% (ASTM).
 6. USE NON-SHRINK GROUT FOR JOINTS, FILLETS AND PIPE PENETRATIONS.
 7. APPLY WATERPROOFING COATING TO EXTERIOR OF MANHOLE IN AREAS WHERE GROUNDWATER IS PRESENT.
 8. AN INTERIOR COATING, WITH A WATER AUTHORITY APPROVED EPOXY RESIN-TYPE MATERIAL, SHALL BE APPLIED TO MANHOLES ON MAINS LARGER THAN 24" IN DIAMETER.
 9. POSITION MANHOLE OPENING OVER THE CENTER OF MANHOLE.

CONSTRUCTION NOTES

- A. CONCRETE PIPE SUPPORTS SHALL EXTEND OUTSIDE OF MANHOLE TO BELL OF FIRST JOINT AND SHALL GRADE PIPE TO SPRING LINE. NOT APPLICABLE FOR FLEXIBLE PIPE.
- B. PIPE PENETRATION INTO MANHOLE SHALL BE FLUSH TO 2" MAX., MEASURED AT SPRINGLINE OF PIPE.
- C. MANHOLE MAY BE CONSTRUCTED OF CONCRETE BLOCK, POURED CONCRETE, OR PRECAST REINFORCED CONCRETE. IF PRECAST CONCRETE IS USED, USE MASTIC GASKETS AND APPLY NON-SHRINK GROUT TO EXTERIOR AND INTERIOR OF EXPANSION JOINTS. IF BLOCK IS USED, APPLY 1/2" THICK MORTAR COATING TO EXTERIOR AND INTERIOR OF MANHOLE.
- D. PRECAST REINFORCED CONCRETE CONCENTRIC CONE. THE CONTRACTOR SHALL PROVIDE SHOP DRAWINGS FOR APPROVAL.
- E. USE MAX. 4 COURSES GRADE MS BRICK ON UNPAVED STREET FOR FUTURE ADJUSTMENT OF MANHOLE FRAME TO PAVEMENT GRADE.
- F. CONCRETE BASE TO BE POURED IN PLACE USING NO. 4 BARS AT 6" O.C. EA. WAY FOR MANHOLE DEPTH OF ≥16'. NO. 4 BARS AT 12" O.C. EA. WAY FOR MANHOLE DEPTH OF <16'.
- H. INVERT ELEVATION OF STUB OR LATERAL AS SHOWN ON PLANS.
- J. 6" GROUT FILLET ON UPPER HALF OF PIPE AND AROUND BASE.
- K. OCTAGONAL CONCRETE PAD, SEE STANDARD DWG. 2461 FOR REFERENCE.
- L. MANHOLE FRAME AND COVER, SEE DRAWING 2109. INSTALL A 24" COVER FOR SEWER LINE ≤24", AND A 32" COVER FOR SEWER LINE >24".
- M. CONCRETE, SEE SPECIFICATION SECTION 101.
- N. SLOPE 1" PER FT. FROM PIPE CROWN.
- P. SHELF TO BE 9" WIDE MIN.
- Q. APPROVED WATERSTOP TO BE COMPATIBLE WITH TYPE OF PIPE.
- R. ELECTRONIC MARKER DEVICE (EMD). SEE STANDARD SPECIFICATION SECTION 170.
- S. CONCRETE COLLAR IN UNPAVED AREAS, SEE STANDARD DRAWING 2461.
- T. APPLY 1/2" THICK MORTAR COATING TO INTERIOR OF OPENING.
- U. #4 REBAR PER STANDARD DRAWING 2461.
- V. TOP OF CONCRETE COLLAR SHALL BE STAMPED WITH LINE SIZE AND FLOW DIRECTION ARROWS. MINIMUM LETTER SIZE SHALL BE 3" IN HEIGHT.

REVISIONS	WATER AUTHORITY
JAN. 2013	SANITARY SEWER MANHOLE TYPE "E"
DWG. 2102	OCT. 2017



DEVELOPMENT HEARING OFFICER (DHO)

Parks and Recreation Department

<https://www.cabq.gov/parksandrecreation>

PR-2020-003484

SD-2023-00048 – PRELIMINARY PLAT

SKETCH PLAT 1-11-23 (DFT)

IDO - 2021

THE GROUP | RON HENSLEY agent for NAFEESA PASHTOON requests the aforementioned action(s) for all or a portion of: LOTS 2 & 3 BLOCK 12 UNIT 3, VOLCANO CLIFFS SUBD zoned R1-D located on MOJAVE ST NW between UNSER BLVD and TESUQUE DR containing approximately 4.25 acre(s). (E-10) [Deferred from 4/12/23, 4/26/23b, 5/10/23b, 5/24/23b]

PROPERTY OWNERS: PASHTOON NAFEESA

REQUEST: CREATE 19 LOTS FROM EXISTING TRACTS.

Comments:

06-14-2023

The National Park Service (NPS) for Petroglyph National Monument, has requested applications be submitted for permits to access and existing sewer line located within Petroglyph National Monument boundaries. The agent/applicant has as of 6/12/2023 - not applied for any permits as directed from the City of Albuquerque nor the NPS. NPS staff have requested a site visit with the agent/applicant to review the connection points and detail the work required. PRD requests that a site visit be completed (at minimum) prior to approval of the preliminary plat with the sewer connection as identified on the plat. This will allow the NPS to follow regulations regarding Federal lands for the specific work that would occur. It also allows City staff an opportunity to verify approval with the land manager prior to any proposed development occurring.

Comments provided by Whitney Phelan, Senior Planner, CABQ Parks & Recreation Department. Please contact via wphelan@cabq.gov or 505-768-5378 with questions or concerns.

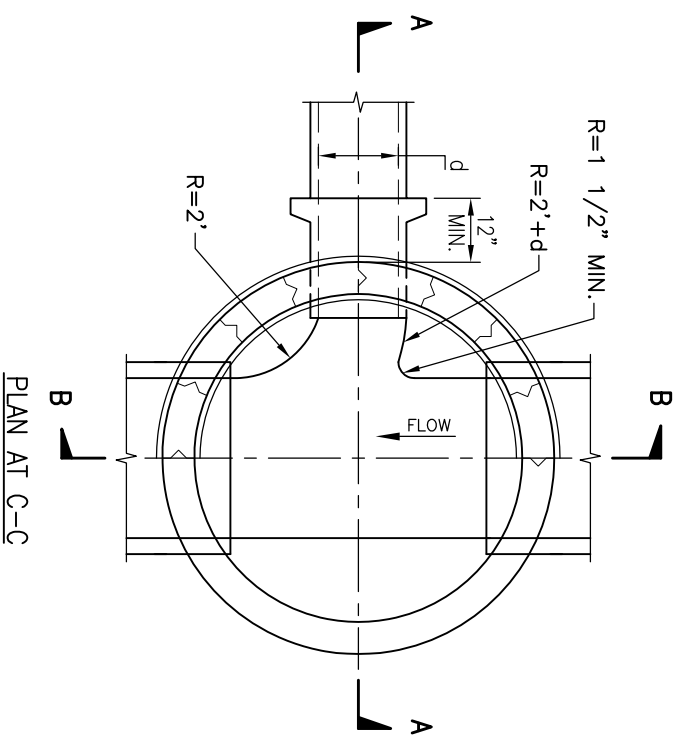

PLAN AT C-C

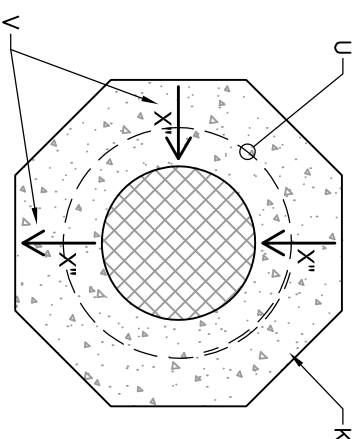

PLAN AT D-D

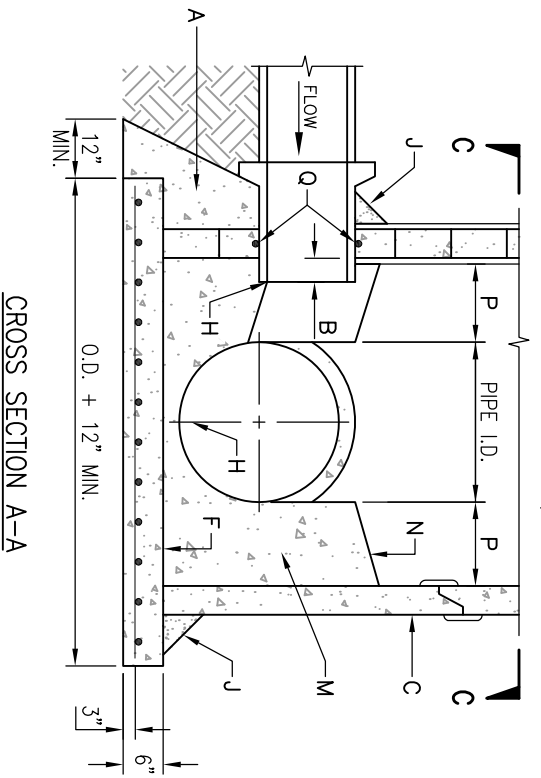
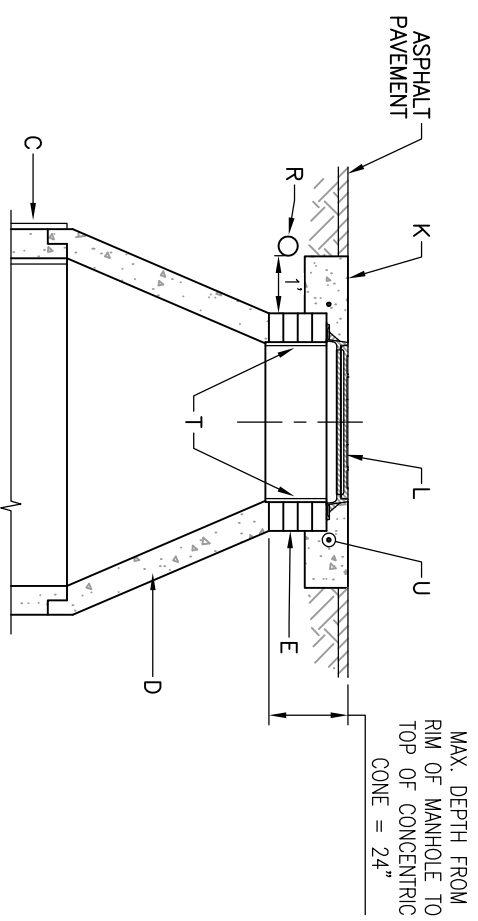

CROSS SECTION A-A

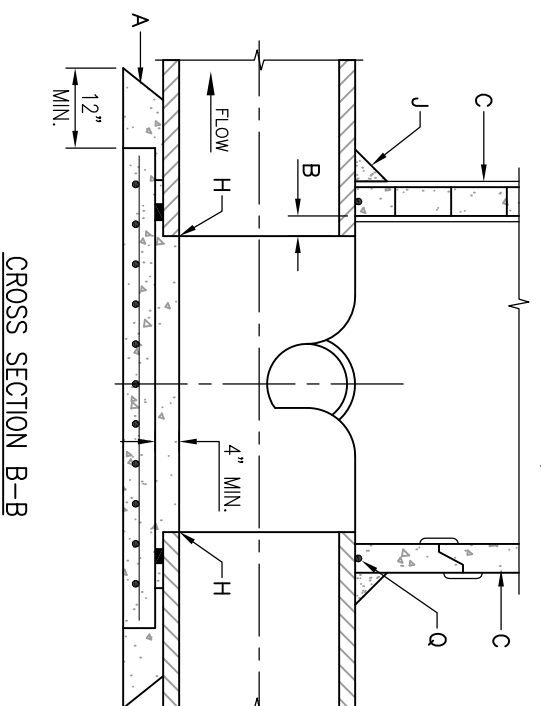
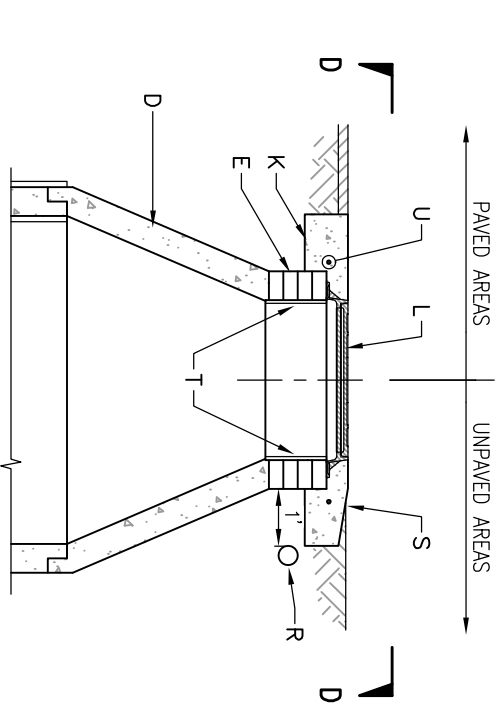

CROSS SECTION B-B

- GENERAL NOTES**
1. USE TYPE "E" MANHOLE FOR DEPTHS OF ≥6' MEASURED FROM INVERT TO RIM.
 2. CONTRACTOR HAS OPTION TO CONSTRUCT TYPE "C" MANHOLE IN LIEU OF TYPE "E" MANHOLE FOR DEPTHS ≥6'.
 3. MANHOLES >18' IN DEPTH SHALL BE CONSTRUCTED OF PRECAST CONCRETE SECTIONS ONLY.
 4. DESIGN APPLIES TO 4' TO 6' I.D. MANHOLES.
 5. COMPACT ALL BACKFILL AROUND MANHOLE TO 95% (ASTM).
 6. USE NON-SHRINK GROUT FOR JOINTS, FILLETS AND PIPE PENETRATIONS.
 7. APPLY WATERPROOFING COATING TO EXTERIOR OF MANHOLE IN AREAS WHERE GROUNDWATER IS PRESENT.
 8. AN INTERIOR COATING, WITH A WATER AUTHORITY APPROVED EPOXY RESIN-TYPE MATERIAL, SHALL BE APPLIED TO MANHOLES ON MAINS LARGER THAN 24" IN DIAMETER.
 9. POSITION MANHOLE OPENING OVER THE CENTER OF MANHOLE.

CONSTRUCTION NOTES

- A. CONCRETE PIPE SUPPORTS SHALL EXTEND OUTSIDE OF MANHOLE TO BELL OF FIRST JOINT AND SHALL GRADE PIPE TO SPRING LINE. NOT APPLICABLE FOR FLEXIBLE PIPE.
- B. PIPE PENETRATION INTO MANHOLE SHALL BE FLUSH TO 2" MAX., MEASURED AT SPRINGLINE OF PIPE.
- C. MANHOLE MAY BE CONSTRUCTED OF CONCRETE BLOCK, POURED CONCRETE, OR PRECAST REINFORCED CONCRETE. IF PRECAST CONCRETE IS USED, USE MASTIC GASKETS AND APPLY NON-SHRINK GROUT TO EXTERIOR AND INTERIOR OF EXPANSION JOINTS. IF BLOCK IS USED, APPLY 1/2" THICK MORTAR COATING TO EXTERIOR AND INTERIOR OF MANHOLE.
- D. PRECAST REINFORCED CONCRETE CONCENTRIC CONE. THE CONTRACTOR SHALL PROVIDE SHOP DRAWINGS FOR APPROVAL.
- E. USE MAX. 4 COURSES GRADE MS BRICK ON UNPAVED STREET FOR FUTURE ADJUSTMENT OF MANHOLE FRAME TO PAVEMENT GRADE.
- F. CONCRETE BASE TO BE POURED IN PLACE USING NO. 4 BARS AT 6" O.C. EA. WAY FOR MANHOLE DEPTH OF ≥16'. NO. 4 BARS AT 12" O.C. EA. WAY FOR MANHOLE DEPTH OF <16'.
- H. INVERT ELEVATION OF STUB OR LATERAL AS SHOWN ON PLANS.
- J. 6" GROUT FILLET ON UPPER HALF OF PIPE AND AROUND BASE.
- K. OCTAGONAL CONCRETE PAD, SEE STANDARD DWG. 2461 FOR REFERENCE.
- L. MANHOLE FRAME AND COVER, SEE DRAWING 2109. INSTALL A 24" COVER FOR SEWER LINE ≤24", AND A 32" COVER FOR SEWER LINE >24".
- M. CONCRETE, SEE SPECIFICATION SECTION 101.
- N. SLOPE 1" PER FT. FROM PIPE CROWN.
- P. SHELF TO BE 9" WIDE MIN.
- Q. APPROVED WATERSTOP TO BE COMPATIBLE WITH TYPE OF PIPE.
- R. ELECTRONIC MARKER DEVICE (EMD). SEE STANDARD SPECIFICATION SECTION 170.
- S. CONCRETE COLLAR IN UNPAVED AREAS, SEE STANDARD DRAWING 2461.
- T. APPLY 1/2" THICK MORTAR COATING TO INTERIOR OF OPENING.
- U. #4 REBAR PER STANDARD DRAWING 2461.
- V. TOP OF CONCRETE COLLAR SHALL BE STAMPED WITH LINE SIZE AND FLOW DIRECTION ARROWS. MINIMUM LETTER SIZE SHALL BE 3" IN HEIGHT.

REVISIONS	WATER AUTHORITY
JAN. 2013	SANITARY SEWER MANHOLE TYPE "E"
DWG. 2102	OCT. 2017

SECTION 900

SANITARY AND STORM SEWER FACILITIES

900.1 GENERAL: This section pertains to the collection and conveyance facilities for sewage and storm runoff in underground piping systems.

900.2 CONTENTS

Section No.	Title
901	Sanitary Sewer Collector and Interceptor Facilities
905	Sanitary Sewer Service Lines
910	Storm Sewer Pipe Installations
912	Polypropylene Pipe for Storm Sewers
915	Storm Sewer Drainage Appurtenances
920	Sanitary Sewer Manholes
921	Storm Manholes
925	Vacuum Sewer Collector, Interceptor and Force Main Facilities

SECTION 901

SANITARY SEWER COLLECTOR AND INTERCEPTOR FACILITIES

901.1 GENERAL:

The construction items, specified in this section, are common to sanitary sewer collector and interceptor facilities.

901.2 REFERENCES

901.2.1 ASTM

D 2321 Standard Practice for Underground Installation of Thermoplastic Pipe for Sewers and Other Gravity-Flow Applications

D 3034 Standard Specification for Type PSM Poly (Vinyl Chloride) (PVC) Sewer Pipe and Fittings

F 679 Standard Specification for Poly (Vinyl Chloride) (PVC) Large-Diameter Plastic Gravity Sewer Pipe and Fittings

F 794 Standard Specification for Poly (Vinyl Chloride) (PVC) Profile Gravity Sewer Pipe and Fittings Based on Controlled Inside Diameter

901.2.2 (intentionally left blank)

901.2.3 This publication per SECTIONS:

- 121 Plastic Pipe
- 131 Fiberglass Pipe
- 701 Trenching, Excavation and Backfill

901.3 MATERIALS

901.3.1 PIPE:

Sewer line pipe and fittings shall be as specified in other sections, as follows:

- Section 121 Plastic Pipe
- Section 131 Fiberglass Pipe

901.4 CERTIFICATION:

The OWNER / ENGINEER will be supplied with a certification on each item or type of material required in the sewer line, as to that item meeting the specifications and / or the reference specifications before that item is installed.

901.5 INSTALLATION

901.5.1 GENERAL

901.5.1.1 Pipe and appurtenances shall be new and unused. The type of pipe to be installed shall be as approved by these specifications or unless otherwise shown on the project construction drawings. Pipe and appurtenances shall be handled in such a manner as to ensure delivery to the trench in sound, undamaged condition. Particular care shall be taken to prevent damage to any pipe coating.

901.5.1.2 The interior of the pipe shall be thoroughly cleaned of foreign material before being lowered into the trench and shall be kept clean during construction operations. When work is not in progress, the open ends of pipe shall be securely closed so that no foreign materials will enter the pipe. Any section of pipe found to be defective before or after installation, shall be replaced with sound pipe, or repaired in a manner satisfactory to the ENGINEER, without additional expense to the OWNER.

901.5.1.3 The CONTRACTOR shall install a plug in the new sewer at any point of connection to an existing system. The CONTRACTOR shall not flush or otherwise discharge any flow into an existing system unless approved in writing by the ENGINEER and Water Authority.

901.5.1.3.1 The plug shall remain in place until the ENGINEER or Water Authority authorizes its removal in writing. Under all circumstances, the CONTRACTOR shall be required to remove all plugs prior to acceptance of the work.

901.5.1.3.2 The CONTRACTOR shall certify in writing the completion of the plug removal task. The certification shall include the locations of removed plugs and corresponding date of removal. The Water Authority assumes no liability for damages caused by plugs inadvertently left in the line by the Contractor.

901.5.1.4 Pipe shall be laid to line and grade as shown on the project construction plans. The bedding of the trench shall be graded and prepared to provide a firm and uniform bearing throughout the entire length of the pipe barrel. Suitable excavation shall be made to receive the bell of the pipe and the joint shall not bear upon the bottom of the trench. All adjustment to the line and grade shall be made by scraping away or filling in with pipe zone material under the body of the pipe, and not by wedging or blocking. When connections are to be made to any existing manhole, pipe, or other improvement, the actual elevation or position of which cannot be determined without excavation, the CONTRACTOR shall excavate for and expose the existing improvement before laying the connecting pipe or conduit. When existing underground improvements may reasonably be expected to conflict with the line or grade established for the new sewer line, the ENGINEER shall request the CONTRACTOR to excavate as necessary to expose and locate such potentially conflicting underground improvements prior to laying the new pipe. Any adjustment in line or grade which may be necessary to accomplish the intent of the construction plans will be made, and the CONTRACTOR will be paid for any additional work resulting from such change in line or grade in the manner provided for in the General Conditions.

901.5.1.5 Connections to existing sanitary sewer manholes shall be made by core drilling through the manhole wall. The CONTRACTOR shall take care to avoid unnecessary damage to the existing manhole.

SECTION 901

SANITARY SEWER COLLECTOR AND INTERCEPTOR FACILITIES

901.5.1.6 Pipe shall be laid upgrade in a continuous operation from structure to structure, with the bell end of the pipe upgrade unless otherwise permitted by the ENGINEER.

901.5.1.7 Sanitary sewer mains shall not be constructed under walkways, sidewalks, curbs and gutters, drive pads, or similar concrete structures by tunneling underneath them. The CONTRACTOR will remove the section of the concrete structure to the nearest full expansion joint or edge.

901.5.1.8 Prior to completely backfilling the sewer excavation, install a green metalized detectable warning tape 12" to 18" below finished grade. The tape shall be detectable with a standard metal pipe locator. The tape shall be a minimum of 2 inches wide and inscribed at 10-foot intervals with the words, "CAUTION BURIED SEWER LINE BELOW". The tape shall be constructed of material that is impervious to alkalis, acids, chemical reagents, and solvents found in the soils.

901.5.1.9 TRACE WIRE

901.5.1.9.1 GENERAL

901.5.1.9.1.1 Trace wire shall be installed on all public sanitary sewer interceptor, collector, and any other lines considered public infrastructure that will be owned and maintained by the Water Authority.

901.5.1.9.1.2 Trace wire shall be installed in such a manner as to be able to properly trace all pipelines as applicable, without loss or deterioration of the signal.

901.5.1.9.2 MATERIALS: The CONTRACTOR shall submit the manufacturer's data on materials to be furnished that indicate compliance with the specifications regarding materials used. Only products or materials listed on the Water Authority Approved Product List shall be used.

901.5.1.9.2.1 For open trench installation, #12 AWG high strength copper clad steel wire with a minimum 450 pound break load and minimum 30 mil HDPE insulation thickness shall be used.

901.5.1.9.2.2 For directional drilling/boaring installation, #12 AWG high strength copper clad steel wire with a minimum 1,150 pound break load minimum 45 mil HDPE insulation thickness shall be used.

901.5.1.9.2.3 For pipe bursting installation, high strength 7x7 stranded copper clad steel wire with 4,700 pound break load and minimum 50 mil HDPE insulation thickness shall be used.

901.5.1.9.3 CONNECTORS:

901.5.1.9.3.1 Tee Connections: Single 3-way locking waterproof connector for 12 AWG. Connectors shall be approved by the manufacturer for direct burial.

901.5.1.9.3.2 Cross Connectors: Two 3-way locking waterproof connectors for 12 AWG with a short jumper wire. Connectors shall be approved by the manufacturer for direct burial.

901.5.1.9.3.3 Necessary Splice Connections: Single 3-way direct bury lug locking connector rated up to 50 volts filled with dielectric silicone sealant to seal out moisture and corrosion and prevent uninsulated wire exposure. Connectors shall be approved by the manufacturer for direct burial. Splices shall only be used on the main line at the end of a trace wire spool or when a Tee Connection cannot be used. The CONTRACTOR shall not cut the main line trace wire.

901.5.1.9.3.4 Non-locking friction fit, twist on or taped connectors are prohibited.

901.5.1.9.4 TEST STATIONS

901.5.1.9.4.1 All trace wire test stations shall be made of corrosion-resistant materials and shall be equipped with two terminals, a roadway-rated flange to prevent the test station from sinking, and a locking cast iron cap with an encapsulated magnet for ease of locating the test station. The test station shall be specifically manufactured for trace wire access/testing.

901.5.1.9.4.2 All grade level/in-ground test stations shall be appropriately identified with "Test Station" and with "Sewer" cast into the cap and color coded Green.

901.5.1.9.4.3 All trace wire test stations must include a manually interruptible conducting/connection link (terminal jumper) between the terminal for the trace wire connection and terminal for the grounding anode wire connection.

901.5.1.9.5 GROUNDING ANODE: All grounding anodes shall be made of magnesium, with a pointed end to enable direct driving into the ground, specifically manufactured for this purpose. The anode shall come factory equipped with an HDPE cap and 20 feet of factory installed #12 AWG copper clad steel wire with 30 mil HDPE coating rated for direct burial at 30 volts with 21% conductivity. The wire shall have a minimum 450 pound break load.

901.5.1.9.6 COLOR CODING: The insulation of the trace wire and the color of the test station caps shall be Green.

901.5.1.9.7 INSTALLATION

901.5.1.9.7.1 TRACE WIRE INSTALLATION

901.5.1.9.7.1.1 The trace wire shall be installed in the same trench and inside bored holes and casing with pipe during pipe installation.

SECTION 901

SANITARY SEWER COLLECTOR AND INTERCEPTOR FACILITIES

901.5.1.9.7.1.2 The trace wire shall be securely bonded together at all wire joints with a locking waterproof connector that complies with this specification to provide electrical continuity.

901.5.1.9.7.1.3 Trace wire connectors shall be installed in a manner that prevents any uninsulated wire exposure.

901.5.1.9.7.1.4 Except for spliced-in repair or replacement connections, trace wire shall be continuous and without splices between each trace wire access point. For required splices, use splice connectors per this specification. Spliced wires must be knotted prior to being inserted in the connector to prevent separation from the connector in case the trace wires are stretched during backfilling operations.

901.5.1.9.7.1.5 Trace wire systems must be installed as a single continuous wire. No looping or coiling of wire is allowed.

901.5.1.9.7.1.6 No breaks or cuts in the trace wire or trace wire insulation shall be permitted.

901.5.1.9.7.1.7 Trace wire installation shall be performed in such a manner that allows proper access for connection of line tracing equipment, proper locating of wire without loss or deterioration of low frequency (512 Hz) signal for distances in excess of 1,500 linear feet, and without distortion of signal caused by multiple wires being installed in close proximity to one another.

901.5.1.9.7.1.8 Any damage occurring during installation of the trace wire must be immediately repaired by removing the damaged wire, and installing a new section of wire with connectors that comply with this specification. Taping and/or spray coating to repair trace wire or trace wire insulation shall not be allowed.

901.5.1.9.7.1.9 Trace wire shall be laid flat on top of the pipe and securely affixed in 6-foot intervals with tape or plastic ties to prevent shifting or damage during backfilling and excavation operations.

901.5.1.9.7.1.10 In occurrences where an existing trace wire is encountered on an existing utility that is being extended or tied into, the new trace wire and existing trace wire shall be connected using splice connectors that comply with this specification.

901.5.1.9.7.1.11 Not used.

901.5.1.9.7.1.12 At service saddles, the trace wire shall not be placed between the saddle and the main.

901.5.1.9.7.1.13 Lay the mainline trace wire continuously by-passing around the outside of manholes, vaults and other structures on the north or east side.

901.5.1.9.7.1.14 For main line intersections, the main line

trace wire shall not be cut.

901.5.1.9.7.1.15 All main line trace wires must be interconnected at intersections, at main line tees and main line crosses. At tees, the three wires shall be joined using a single 3-way locking connector. At crosses, the four wires shall be joined using two 3-way connectors with a short jumper wire between them.

901.5.1.9.7.1.16 All trace wire termination points shall be terminated with a grounding anode.

901.5.1.9.7.1.17 For repairs and rehabilitations, trace wire shall be installed on the new line per this specification. The ends of rehabilitated/replaced pipeline segments shall be connected if existing trace wire exists or shall be terminated with a grounding anode.

901.5.1.9.7.1.18 If repairs are made to a line with a trace wire, Contractor must ensure trace wire is connected with an approved splice connector and test the trace to the next existing test station.

901.5.1.9.8 TEST STATIONS

901.5.1.9.8.1 Test stations shall be installed at the following locations as outlined in the Standard Detail Drawings:

901.5.1.9.8.1.1 At sanitary sewer manholes and sanitary sewer wet wells;

901.5.1.9.8.1.2 At sanitary sewer force main valves;

901.5.1.9.8.1.3 At sanitary sewer vacuum valves;

901.5.1.9.8.2 A minimum of 6 inches of excess/slack wire is required in all trace wire test stations after meeting final elevation. Group and zip-tie excess wire. Do not coil.

901.5.1.9.8.3 Test stations shall be spaced approximately every 1,000 feet and shall not be spaced greater than 1,500 feet apart. Test stations do not need to be installed at each location identified above provided that the spacing between test stations does not exceed 1,500 feet.

901.5.1.9.9 GROUNDING

901.5.1.9.9.1 Trace wire must be properly grounded at all termination points.

901.5.1.9.9.2 Grounding of trace wire shall be achieved by use of a drive-in magnesium grounding anode rod buried at the same depth as the trace wire.

901.5.1.9.9.3 Where the grounding anode wire will be connected to a trace wire test station, a minimum of 6 inches of excess/slack wire is required after meeting final elevation.

SECTION 901

SANITARY SEWER COLLECTOR AND INTERCEPTOR FACILITIES

901.5.1.9.9.4 When grounding the trace wire in areas where the trace wire is continuous and neither the mainline trace wire nor the grounding anode wire will be terminated at/above grade, install grounding anode directly beneath and at the same depth as the trace wire. Do not coil excess wire from grounding anode. The grounding anode wire shall be trimmed to an appropriate length before connecting to trace wire with a splice connector. Install with spliced connection to main trace wire at beginning or endpoints of pipe runs, only when there is no test station box present. If test station is nearby/available, red trace wire from magnesium grounding anode shall be continuous to the terminal in the test station (no other connections or splices).

901.5.1.9.10 TESTING REQUIREMENTS

901.5.1.9.10.1 Contractor shall provide equipment for trace test and shall perform a trace test on all trace wire in the presence of the ENGINEER and WATER AUTHORITY INSPECTOR. If the trace wire is found to be not continuous upon testing, the CONTRACTOR shall repair or replace the failed segment of the wire, and shall be responsible for the cost of any trenching, backfill, repaving and other improvements necessary to complete the trace wire repair. Contractor is encouraged to test trace wire prior to backfill so any issues can be addressed prior to backfill. Passing test results shall be provided for all pipe segments within the Engineer of Record’s as-built data and plan set. To pass the continuity test, the following conditions must be met:

901.5.1.9.10.1.1 Trace test shall be performed by using a metallic locator with audible tone and numeric values for certification of the facility locations and shall be identifiable between access points.

901.5.1.9.10.1.2 The wire shall be accessible at all access points and be identifiable between access points.

901.5.2 PLASTIC PIPE INSTALLATION:

901.5.2.1 Plastic sewer pipe shall be connected and placed in the trench in accordance with the manufacturer’s recommendations. Where a conflict arises with this Specification, this Specification shall control. Trenching, embedment, and backfill shall be as specified in Section 701.

901.5.2.2 The reference mark (a distinct circumferential line) is placed on the pipe’s spigot end by the manufacturer to indicate the correct depth of spigot penetration into the pipe gasket joint. If the pipe is seated too deep or too shallow, the pipe may buckle or separate due to thermal expansion / contraction. Spigot penetration shall be within ¼-inch of the manufacturer’s recommended mark.

901.5.2.3 For plastic or fiberglass pipe connection to manholes the CONTRACTOR shall install an appropriately sized and approved press seal gasket. The gasket shall be installed per manufacturer’s directions. No direct payment

shall be made for this item. This cost shall be incidental to the pipe’s bid item.

901.5.2.4 Not less than thirty (30) days after the installation and backfilling of plastic or fiberglass sewers, including any service connections, the CONTRACTOR shall, in the presence of the ENGINEER, test deflection of the pipe with a mandrel. The mandrel shall be hand pulled. All pipe with deflections in excess of five (5) percent of the base internal diameter, as determined by ASTM D 3034, ASTM F 679, or ASTM F 794 shall be excavated, re-rounded, backfilled and retested after an additional period of at least thirty (30) days. Mandrels shall have nine (9) ribs and be only hand pulled through the test section. The CONTRACTOR shall furnish the mandrels. The length of the minimum radius portion of the mandrel shall not be less than the one-third (1/3) of the nominal diameter of the pipe tested. The minimum mandrel diameter shall be no less than ninety (90) percent of the pipe inside diameter. The pipe shall be flushed and cleaned by the CONTRACTOR prior to testing. No flow will be permitted in the pipe while testing for deflections.

901.5.2.5 All expense for trenching, backfill, compaction, paving, and related work that is required because of failure to meet deflection test requirements shall be borne by the CONTRACTOR.

901.5.2.6 Acceptance of plastic pipe or fiberglass pipe sewers will be made only after these deflection test requirements have been met.

901.5.2.7 Minimum Diameters of Mandrels

901.5.2.7.1

<u>Nominal Pipe Size Diameter</u>	<u>Min. Mandrel</u>
8 in.	7.2 in.
10 in.	9.0 in.
12 in.	10.8 in.
15 in.	13.5 in.
18 in.	16.2 in.
21 in.	18.9 in.
24 in.	21.6 in.
27 in.	24.3 in.

901.6 JOINTS FOR PIPE

901.6.1 (deleted section)

901.6.2 (deleted section)

SECTION 901

SANITARY SEWER COLLECTOR AND INTERCEPTOR FACILITIES

901.6.3 JOINT FOR PLASTIC SEWER PIPE (PVC):

901.6.3.1 Refer to ASTM D 2321 and ASTM F 794 for pipe laying and joining of pipe guidelines.

901.6.3.2 Prior to the laying of pipe, each pipe component shall be inspected for damage and cleaned. Damaged components shall be rejected or repaired.

901.6.3.3 All joints will be assembled in accordance with manufacturer's published recommendations. If a lubricant is required to facilitate assembly, it shall have no detrimental effect on the gasket or on the pipe when subjected to prolonged exposure. Proper jointing may be verified by rotation of the spigot by hand or with a strap wrench. If unusual joining resistance is encountered or if the insertion mark does not reach the flush position, disassemble the joint components and repeat the assembly steps. Note that fitting bells may permit less insertion depth than pipe bells. When mechanical equipment is used to assemble joints, care should be taken to prevent over-insertion.

901.6.4 JOINT FOR FIBERGLASS PIPE

901.6.4.1 All joints shall be as specified in Section 131 FIBERGLASS PIPE

901.7 TESTING FOR LEAKAGE

901.7.1 GENERAL:

901.7.1.1 Unless otherwise shown on the construction drawings or specifically deleted by the ENGINEER, in writing, all sanitary sewers shall be tested for leakage.

901.7.1.2 The CONTRACTOR may Air Test the sanitary sewer line before backfilling the trench to aid the CONTRACTOR in checking the installation for any defects. Such testing is at the option of the CONTRACTOR and shall not constitute an acceptance test under these specifications.

901.7.1.3 The test for acceptance and compliance with these specifications shall be performed after the pipe zone backfilling has been completed. In the case of new sanitary sewer lines with house laterals included as an integral part of the project, the test for acceptance and compliance with these specifications shall be performed after the house laterals or stubs have been completed and backfilled. The CONTRACTOR has the option to leave the end of the service line exposed.

901.7.1.4 If the leakage, as shown by the test, is greater than allowed by these specifications, the pipe shall be overhauled at the CONTRACTOR's expense and, if necessary, re-laid until the pipe will satisfactorily pass the test.

901.7.1.5 The CONTRACTOR shall, at no additional expense to the OWNER, furnish all water, material, tools and labor for performing the required tests. All tests shall be made under observation of the ENGINEER.

901.7.2 INFILTRATION TEST:

901.7.2.1 An Infiltration Test shall be used only when excessive ground water prevents satisfactory testing by either the Exfiltration Test or the Air Test. In addition, the Infiltration Test must be performed after backfilling, before any service connections are functioning and at a time when the ground water is over the entire section of pipe and at or near its maximum level.

901.7.2.2 The procedure for conducting an Infiltration Test shall be as follows:

901.7.2.2.1 The pipe section shall be cleaned.

901.7.2.2.2 Determine the groundwater table. The groundwater table shall be determined for each section of sanitary sewer tested.

901.7.2.2.3 Plug the upstream pipe outlet from upstream manhole of the sections being tested with a plug which will assure a tight seal against flow from the upstream portion of the sewer system. Also plug all house laterals and any other connections to the section being tested.

901.7.2.2.4 Install a 90-degree V-notch weir in the downstream manhole of the section being tested. Weir must be installed plumb and sealed to the pipe wall surface.

901.7.2.2.5 A sufficient period of time must be allowed to permit the infiltrated waters to collect and flow over the weir. Water shall flow over the weir for at least 30-minutes prior to taking measurements.

901.7.2.2.6 The head (H) of water flowing over the weir must be measured accurately and the measurement taken at least 18-inches upstream from the crest of the weir.

901.7.2.2.7 Discharge over the 90-degree V-notch weir shall be calculated according to:

$$Q = 3240 H^{2.5}$$

H = Head in inches
Q = Discharge in gallons per day

901.7.2.3 The allowable infiltration shall be 200-gallons per inch of pipe diameter per mile of pipe per day. When there is significantly more than two feet of groundwater above the top of the pipe at the highest point of the section being tested, ten percent additional infiltration above the permitted 200 gal/in.-dia/mi/day limit will be allowed for every 2-foot of additional head.

901.7.2.4 Under all circumstances, the CONTRACTOR shall be required to remove all plugs prior to acceptance of

SECTION 901

SANITARY SEWER COLLECTOR AND INTERCEPTOR FACILITIES

the work. The Water Authority assumes no liability for damages caused by plugs inadvertently left in the line by the Contractor. The CONTRACTOR shall certify in writing to the Water Authority the completion of the plug removal task. The certification shall include the locations of removed plugs and corresponding date of removal.

901.7.3 EXFILTRATION TEST

901.7.3.1 An Exfiltration Test may be conducted wherever the groundwater level is below the crown of the pipe at the highest elevation of the section of sanitary sewer being tested. If the groundwater level is above the crown of the pipe either the Air Test, properly adjusted, or Infiltration Test should be used.

901.7.3.2 The procedure for conducting an Exfiltration Test shall be as follows:

901.7.3.2.1 The pipe section shall be cleaned.

901.7.3.2.2 Plug the downstream pipe outlet to the manhole with a plug which will assure a tight seal against water leakage. Also plug all house laterals and any other connections to the section being tested.

901.7.3.2.3 If the upstream manhole is to be used as a reservoir for maintaining the pressure head on the sewer pipe, the inlet sewer pipe of pipes must be plugged. If a standpipe is to be used as a reservoir for maintaining the pressure head on the sewer pipe, the standpipe must be connected to the sewer pipe in the upstream manhole by a tightly sealed connection.

901.7.3.2.4 The amount of water (volume required to fill the section of sewer under test plus the manhole or standpipe) shall be calculated.

901.7.3.2.5 Water shall then be introduced through the manhole or standpipe. The amount of water introduced shall be metered. The amount of water introduced to fill the sewer should be approximately equal to the calculated amount. If the amount of water required to fill the sewer pipe is significantly greater than the calculated amount, it is an indication of a leak or leaks and consequent saturation of the backfill around the sewer pipe. Saturation of the backfill will invalidate the test.

901.7.3.2.6 The level of water in the manhole or standpipe shall be at least two feet above the crown of the pipe at the highest section of the section of sanitary sewer being tested.

901.7.3.2.7 After filling the pipe at least one hour shall be allowed for water absorption in the pipe. For some materials, up to six hours may be required. After the absorption period, the manhole or standpipe shall be refilled to the established measuring mark and the test begun.

901.7.3.2.8 If the upstream manhole is used as a reservoir for maintaining the pressure head on the sewer pipe, the difference in water surface elevation from original to final level in a two hour period shall be used to calculate the water lost. The water lost in the two hour period shall be converted into gallons per day. If a standpipe is used as a reservoir for maintaining the pressure head on the sewer pipe, the standpipe shall be refilled periodically during the two-hour test period to maintain an essentially constant head on the test section of pipe. The amount of water added shall be measured and shall be used to calculate the loss in gallons per day.

901.7.3.2.9 The allowable exfiltration shall be computed based upon the average pressure head above the crown of the pipe for the section tested as follows:

$$\text{Allowable leakage} = \frac{\sqrt{h}}{\sqrt{3}} \times 200$$

Allowable leakage in gallons per inch of pipe diameter per mile of pipe per day

h = average pressure head above the crown of the pipe, in feet (elevation of water at center run)

901.7.3.2.10 When the upstream manhole is used as a reservoir for maintaining the pressure head, the allowable leakage from the manhole shall be added to the allowable leakage calculated for the sewer pipe.

901.7.3.3 If the sanitary sewer line fails to pass the Exfiltration Test, a re-test shall be permitted only after the groundwater conditions surrounding the pipe return to a condition similar to those existent at the beginning of the test period. The groundwater elevation shall be determined prior to initiation of a second test.

901.7.3.4 Under all circumstances, the CONTRACTOR shall be required to remove all plugs prior to acceptance of the work. The Water Authority assumes no liability for damages caused by plugs inadvertently left in the line by the Contractor. The CONTRACTOR shall certify in writing to the Water Authority the completion of the plug removal task. The certification shall include the locations of removed plugs and corresponding date of removal.

901.7.4 AIR TEST:

901.7.4.1 An Air Test may be conducted under all conditions of groundwater levels surrounding the sanitary sewer pipe. If the groundwater is above the crown of the pipe, the air pressure shall be increased by an increment equal to the pressure exerted by the groundwater over the pipe.

901.7.4.2 The procedure for conducting an Air Test shall be as follows:

SECTION 901

SANITARY SEWER COLLECTOR AND INTERCEPTOR FACILITIES

901.7.4.2.1 Clean the pipe section (manhole to manhole reach of sewer) being tested by propelling a snug-fitting inflated ball, or other adequate method, through the pipe with water. It is important that the pipe is thoroughly wetted if consistent results are to be expected.

901.7.4.2.2 Plug all pipe outlets with pneumatic plugs. The pneumatic plugs shall be able to resist internal testing pressures without requiring external bracing. Give special attention to house laterals.

901.7.4.2.3 Determine the groundwater level surrounding the section of sewer under test. If the groundwater level is above the crown of the pipe, the test pressures shall be increased by 0.43 psig for each foot of water above the average elevation of the crown of the pipe. If the average vertical height of groundwater above the pipe invert is more than 12.7 feet, the section so submerged shall be tested using 9.0 psig as the starting test pressure. In no case should the starting test pressure exceed 9 psig.

901.7.4.2.4 Introduce air slowly to the section of pipe under evaluation until the internal air pressure is raised to 4.0 psig plus any increase required by a high groundwater level.

901.7.4.2.5 Allow the air pressure to stabilize. Air may be added slowly to maintain a pressure in the 3.5 to 4.0 psig (plus groundwater allowance) for two minutes.

901.7.4.2.6 After the stabilization period, when the pressure reaches exactly 3.5 psig (plus groundwater allowance) the stopwatch is started and when the pressure

reaches exactly 2.5 psig (plus groundwater allowance) the stopwatch is stopped.

901.7.4.2.7 If the time required for a one pound pressure drop is not less than the allowable time for the pipe section under test to lose air, the section shall pass the leakage test.

901.7.4.2.8 If there has been no leakage (zero psi drop) after one hour of testing, the test section shall pass the leakage test.

901.7.4.3 In all cases where an Air Test is conducted, the manholes shall be tested separately as previously specified.

901.7.4.4 All persons conducting an Air Test must be aware that an Air Test may be dangerous if improperly conducted. It is extremely important and essential that all plugs be properly installed and braced by the CONTRACTOR in such a way that blowouts are prevented.

901.7.4.5 Under all circumstances, the CONTRACTOR shall be required to remove all plugs prior to acceptance of the work. The Water Authority assumes no liability for damages caused by plugs inadvertently left in the line by the Contractor. The CONTRACTOR shall certify in writing to the Water Authority the completion of the plug removal task. The certification shall include the locations of removed plugs and corresponding date of removal.

901.7.5 AIR TESTING TABLE: Table 901.7.5.1 will be used to determine the required test duration for the section of line being tested.

SECTION 901

SANITARY SEWER COLLECTOR AND INTERCEPTOR FACILITIES

TABLE 901.7.5.1
LOW-PRESSURE AIR TEST TIME SPECIFICATION
FOR A NON-PRESSURE SEWER LINE

901.7.5.2 EXPLANATION AND USE OF TABLE

Explanation of Tables

(A) Pipe Diameter (inches)	(B) Minimum Time (min:sec)	(C) Maximum Length for Minimum Time (feet)	(D) Time for Longer Length (seconds)	(E)								
				Specification Time for Length (L) Shown (min:sec)								
				100 ft	150 ft	200 ft	250 ft	300 ft	350 ft	400 ft	450 ft	
4	3:46	597	.38*L	3:46	3:46	3:46	3:46	3:46	3:46	3:46	3:46	3:46
6	5:40	398	.854*L	5:40	5:40	5:40	5:40	5:40	5:40	5:42	6:24	
8	7:34	298	1.52*L	7:34	7:34	7:34	7:34	7:36	8:52	10:08	11:24	
10	9:26	239	2.374*L	9:26	9:26	9:26	9:53	11:52	13:51	15:49	17:48	
12	11:20	199	3.418*L	11:20	11:20	11:24	14:15	17:05	19:56	22:47	25:38	
15	14:10	159	5.342*L	14:10	14:10	17:48	22:15	26:42	31:09	35:36	40:04	
18	17:00	133	7.692*L	17:00	19:13	25:38	32:03	38:27	44:52	51:16	57:41	
21	19:50	114	10.47*L	19:50	26:10	34:54	43:37	52:21	61:00	69:48	78:31	
24	22:40	99	13.674*									102:3
			L	22:47	34:11	45:34	56:58	68:22	79:46	91:10	3	
27	25:30	88	17.306*						100:5	115:2	129:4	
			L	28:51	43:16	57:41	72:07	86:32	7	2	8	
30	28:20	80	21.366*						124:3	142:2	160:1	
			L	35:37	53:25	71:13	89:02	106:50	8	6	5	
33	31:10	72	25.852*						150:4	172:2	193:5	
			L	43:05	64:38	86:10	107:43	129:16	3	1	3	
36	34:00	66	30.768*						179:2	205:0	230:4	
			L	51:17	76:55	102:34	128:12	153:50	9	7	6	
42	39:48	57	41.883*						244:1	279:1	314:0	
			L	69:48	104:42	139:37	174:30	209:24	9	3	7	
48	45:34	50	54.705*						319:0	364:4	410:1	
			L	91:10	136:45	182:21	227:55	273:31	6	2	7	
54	51:02	44	69.236*						403:5	461:3	519:1	
			L	115:2	4	173:05	230:47	228:29	346:11	3	4	6
60	56:40	40	85.476*						498:3	569:5	641:0	
			L	142:2	8	213:41	284:55	356:09	427:23	7	0	4

- Column A Nominal diameter of pipe (any pipe material)
- Column B Minimum duration of air test up to a maximum of length of line being tested - (e.g., 0-feet through 298-feet of 8-inch PVC: Test Duration: 7 minutes 34 seconds)
- Column C Maximum length of line associated with minimum duration of time for the air test shown in Column B

SECTION 901

SANITARY SEWER COLLECTOR AND INTERCEPTOR FACILITIES

Column D of air test	L = length of line in feet; product of computation yields duration (e.g., 250-feet of 12-inch PVC where ground water is not present) Test Duration— $3.418 * (250) = 854.5 \text{ sec.} = 14 \text{ min. } 15 \text{ sec.}$
Column E	Duration of air test for given incremental lengths of line.

901.8 CLEANING AND INSPECTION

901.8.1 CLEANING: No pipe spalls, rocks, dirt, joint compounds, cement mortar and other trash or obstructions shall be left in a sewer pipe of any size or type. During the flushing operations the manhole outlet shall be bagged or plugged so that debris will not be carried into or contaminate an existing or active line.

901.8.1.1 Under all circumstances, the CONTRACTOR shall be required to remove all plugs prior to acceptance of the work. The Water Authority assumes no liability for damages caused by plugs inadvertently left in the line by the Contractor. The CONTRACTOR shall certify in writing to the Water Authority the completion of the plug removal task. The certification shall include the locations of removed plugs and corresponding date of removal.

901.8.2 TELEVISION:

901.8.2.1 All completed sewer lines shall be inspected by a television camera before lines become operational or final acceptance of the installation.

901.8.2.2 After the CONTRACTOR has cleaned, flushed, and retrieved all debris and plugs in the line, the CONTRACTOR will notify the project engineer that the line is ready for television inspection. The CONTRACTOR in the presence of the ENGINEER or the engineer's representative shall televise the line with televising equipment specifically designed and constructed for sewer line visual inspection.

901.8.2.2.1 The television camera shall be of color and equipped with a rotating lens capable of 360-degree rotation with zoom focus and a wide-angle optical lens permitting spontaneous focal adjustments, allowing viewing of service lateral connections, joints, pipe walls, etc.

901.8.2.2.2 A television report log, completed on the OWNER'S log form, shall be maintained during the television inspection. This log shall be completed to the OWNER'S satisfaction noting the location, project title, name of OWNER, date, type of pipe material, line size, location of services (live or stub-outs), manhole or station numbers, and any abnormal or line defects within the line segment.

901.8.2.2.3 The CONTRACTOR shall be responsible for subsequent televising when line repairs are required or when the previous televising is not satisfactory to the OWNER.

901.8.2.3 When the televising is complete, the CONTRACTOR shall turn over the complete television report logs and the recordings in a format acceptable to the Water Authority.

901.9 MEASUREMENT AND PAYMENT

901.9.1 SANITARY SEWER PIPE: Installed pipe shall be measured and paid for as follows:

901.9.1.1 For straight lines, the pipe length shall be the intervening distance between the centers of manholes along a line parallel to the pipe invert.

901.9.1.2 For curvilinear lines, the pipe length shall be the intervening arc distance between the centers of manholes along a line parallel to the pipe invert.

901.9.1.3 Payment for pipe will be in accordance with the unit price per linear foot per size and material as defined in the Bid Proposal, and shall include: pipe installed in the trench, jointing and coupling materials, and other materials necessary to connect to other sections of pipe, manholes, and other appurtenances.

901.9.2 CONNECTIONS: Connections, tying new sewer lines into existing manholes, shall be measured and paid for on a unit price per each within the size increments as specified in the Bid Proposal. Connections to the shelf section of the floor will not be considered for payment.

901.9.3 VERTICAL DROPS: Vertical drops at manholes shall be measured by the linear foot of pipe from the invert of the sewer line to be dropped to the spring line of the receiving main. Payment will be made on the unit price per linear foot per size and type of pipe as specified in the Bid Proposal.

901.9.4 TESTING:

901.9.4.1 Infiltration, exfiltration, and air tests of sewer mains shall include sewer service lines to the property lines, right-of-way lines, and easement lines as installed per the construction plans. No payment will be made for the initial test or subsequent tests.

SECTION 901

SANITARY SEWER COLLECTOR AND INTERCEPTOR FACILITIES

901.9.4.2 Television inspection and documentation is considered incidental and shall be included in the construction item's unit cost unless otherwise specified in the Bid Proposal.

901.9.4.3 There will be no payment for required testing of sanitary sewer manholes.

901.9.4.4 No payment will be made for deflection tests after the required waiting period for PVC sewer pipe installations.

901.9.5 REMOVAL AND DISPOSAL OF SANITARY SEWER PIPE: Removal and disposal of sanitary sewer lines shall be measured by the linear foot within the specified pipe size increments. Payment will be made on the unit price per linear foot of specified pipe size in the Bid Proposal. Trenching, backfilling, and pavement removal and replacement will be paid for based on the unit prices for each appropriate bid item in the Bid Proposal. If new pipe is to be installed in the same trench as the removed pipe, only one payment will be made for trenching backfilling, and pavement removal and replacement.

901.9.6 TRACE WIRE: Trace Wire: All work associated with the installation of the trace wire and system shall be considered incidental to the installation cost of the pipeline being traced.

SECTION 905

SANITARY SEWER SERVICE LINES

905.1 GENERAL

905.1.1 The requirements of this section apply only to sanitary sewer service lines installed or reconnected within the public right-of-way or easement. Although the maintenance of sanitary sewer lines is the responsibility of the property owner, including the portion within the public right-of-way as established by City Ordinance, the CONTRACTOR shall be responsible for the integrity of the installation or reconnection of all sanitary sewer service lines during the warranty period.

905.1.2 Sanitary sewer service lines shall be installed at all locations shown on the construction plans. The CONTRACTOR shall be aware of the importance of accurately recording coordinate horizontal and vertical locations of sanitary sewer service lines.

905.2 REFERENCES

905.2.1 ASTM:

- A 74 Standard Specification for Cast Iron Soil Pipe and Fittings
- D 1557 Standard Test Method for Laboratory Compaction Characteristics of Soil Using Modified Effort
- D 2661 Standard Specification for Acrylonitrile-Butadiene-Styrene (ABS) Schedule 40 Plastic Drain, Waste, and Vent Pipe and Fittings
- D 2665 Standard Specification for Poly (Vinyl Chloride) (PVC) Plastic Drain, Waste, and Vent Pipe and Fittings

905.2.2 This publication:

SECTION 170 Electronic Marker Devices

SECTION 701 Trenching, Excavation and Backfill

905.3 MATERIALS

905.3.1 Materials to be utilized on the project shall be those listed in the current Water Authority Approved Products List. All materials not listed must be submitted to the ENGINEER for approval no

less than thirty (30) calendar days prior to the proposed date of use.

905.3.2 The CONTRACTOR shall be responsible for assuring that the supplied saddle is compatible with the size and type of both the collection line and service line. Saddles shall be so constructed to have a positive stop to prevent service line from protruding into the main.

905.3.2.1 A 2½-inch wide strap will be required when saddle is attached to the collector line.

905.3.3 Materials to be utilized in the connection of sanitary sewer services to manholes shall be those listed in the current Water Authority Approved Products List. Manhole connections shall only be allowed if shown on the construction plans or approved by the ENGINEER.

905.3.4 Service risers, if required, shall be PVC Schedule 40 pipe conforming to ASTM D 2665, cast iron soil pipe (service weight) conforming to ASTM A 74, or ABS Schedule 40 sewer pipe conforming to ASTM D 2661. Only PVC or ABS shall be used when connecting to flexible pipe.

905.3.5 Fittings shall be compatible with the service line material. PVC or ABS fittings shall be schedule 40 injection molded only.

905.3.6 Service line laterals shall be cast iron soil pipe (service weight), PVC Schedule 40, or ABS Schedule 40.

905.4 INSTALLATION (NEW CONSTRUCTION STUB-OUTS)

905.4.1 Service lines shall be installed to the right-of-way line or 5-feet beyond any existing or proposed improvements (i.e., pavement, curb and gutter, sidewalk, etc.).

905.4.2 Saddle connections shall be installed at a 45-degree angle (upward) above the springline of the main sewer and shall be spaced a minimum of 3 feet apart (centerline to centerline).

905.4.3 Service lines shall be installed at a minimum slope of 2 percent with a minimum bury at the terminus of 4 feet, unless otherwise authorized by the ENGINEER. The pipe shall be placed on suitable bedding having a soil compaction density of not less than 95 percent of maximum density, as determined

SECTION 905

SANITARY SEWER SERVICE LINES

by ASTM D 1557. The pipe shall be uniformly supported by the bedding. Backfill of the service line shall be carefully placed and compacted per the requirements of Section 701.

905.4.4 The terminus of the service line shall be plugged with an end cap compatible with the pipe size and material. An electronic marker device shall be placed above the service tap at the main and over the end of the service line at the property line per Section 170. An "S" (3 inches high and ¼ inch depth) shall be stamped or saw-cut into top of the curb surface directly over the service.

905.4.5 RECORD INFORMATION: The CONTRACTOR shall provide coordinates, accurate to within 0.3 feet, determined from a field survey by a Professional Surveyor, licensed in the state of New Mexico, to the ENGINEER regarding the horizontal and vertical location of the service at the connection point to the public sewer collector line. Use the NAD 1983 NM STATE PLANE CENTRAL ZONE for x and y coordinates and NAVD 1988 for z coordinate. A report certified by the licensed Professional Surveyor shall be referenced on the Record Drawings.

905.5 RISERS

905.5.1 Risers shall be utilized where the sewer main is 15-feet or greater in depth. The riser shall extend to an elevation such that the service line can be installed as specified in Subsection 905.4.3.

905.5.2 The riser shall be installed in accordance with the Standard Detail Drawings. The riser shall be one length of pipe cut to the appropriate length as necessary, unless otherwise approved by the ENGINEER.

905.5.3 RECORD INFORMATION: The CONTRACTOR shall provide coordinates, accurate to within 0.3 feet, determined by a field survey by a Professional Surveyor, licensed in the state of New Mexico, to the ENGINEER regarding the horizontal and vertical location of the service. Coordinates shall be provided at the service tee and at the top elbow of the riser on the service. Use the NAD 1983 NM STATE PLANE CENTRAL ZONE for x and y coordinates and NAVD 1988 for z coordinate. A report certified by the licensed Professional Surveyor shall be referenced on the Record Drawings.

905.6 SERVICE RECONNECTIONS

905.6.1 On replacement/rehabilitation type projects, all existing services shall be reconnected to the new sewer main utilizing new saddles and service line pipe, except for Cured-In-Place rehabilitations. The length of removed existing service line shall be as necessary to accommodate the trench excavation and backfill conditions.

905.6.2 The CONTRACTOR shall visually assess the condition of the existing service line and notify the ENGINEER of any obviously deteriorated or defective conditions. The ENGINEER or CONTRACTOR shall notify the property owner of the situation and the property owner shall be given the opportunity to visually assess the service within a reasonable amount of time as dictated by normal construction activity.

905.6.3 The CONTRACTOR shall connect the new service line pipe to the existing pipe at the same slope and alignment as the existing service. Particular care shall be taken to assure a sound connection. The service line shall be uniformly supported on suitable bedding compacted to a density of not less than 95 percent of maximum density, as determined by ASTM D 1557. If service lines are reconnected such that the pipe is not fully supported, hand tampers shall be used to properly compact under the pipe.

905.6.4 The CONTRACTOR shall place an electronic marker device above the service connection to the public sewer line per Section 170.

905.6.5 The CONTRACTOR shall stamp or saw-cut an "S" (3 inches high and ¼ inch depth) into top of curb surface directly over the service line.

905.7 RECORD INFORMATION: The CONTRACTOR shall provide coordinates, accurate to within 0.3 feet, determined by a field survey by a Professional Surveyor, licensed in the state of New Mexico, to the ENGINEER regarding the horizontal and vertical location of the service. Coordinates shall be provided at the service tee or saddle tap, and if applicable at the top elbow of a riser. Use the NAD 1983 NM STATE PLANE CENTRAL ZONE for x and y coordinates and NAVD 1988 for z coordinate. A report certified by the licensed Professional Surveyor shall be referenced on the Record Drawings.

SECTION 905

SANITARY SEWER SERVICE LINES

905.8 MEASUREMENT AND PAYMENT

905.8.1 Sanitary sewer service lines installed on new construction shall be measured by the linear foot horizontally from the center of the sewer main, or top of riser, if applicable, to the end of the service line. Payment shall be made at the unit price per linear foot and shall include the saddle connection, pipe, trenching, compaction and backfill, electronic marker device, testing, and all incidental work necessary to complete the installation.

905.8.2 Sanitary sewer service risers shall be measured by the vertical foot from the top of the sewer main to the top of the riser. Payment shall be made at the unit price per vertical foot, and shall include the pipe and casing (if required).

905.8.3 Sanitary sewer service reconnections shall be measured per each. Payment shall be made at the unit price per each reconnection shall include the saddle connection, new service pipe, connection to the existing service line, and all incidental work necessary for a complete reconnection.

SECTION 910

STORM SEWER PIPE INSTALLATIONS

910.1 GENERAL

910.1.1 The construction items, specified in this section, are common to storm sewer pipe installation and pipe type culverts.

910.1.2 Reinforced concrete pipe shall be used for storm sewer pipe installations or pipe type culverts. Corrugated metal pipe may be used for pond outfall structures/risers and for stormwater infiltration. Polypropylene may be used under certain conditions; see Specification 912.

910.2 REFERENCES

910.2.1 ASTM

C361 Standard Specification for Reinforced Concrete Low Head Pressure Pipe

C443 Standard Specification for Joints for Concrete Pipe and Manholes, Using Rubber Gaskets

C478 Standard Specification for Precast Reinforced Concrete Manhole Sections

F2764 Polypropylene Pipe 6 to 60 inches

D3212 ASTM D3212 Plastic Pipe Joints

D2321 Underground Installation of Thermoplastic Pipe

F2881 Polypropylene Pipe 12 to 60 inches

F477 Elastomeric Seals of Joining Plastic Pipe

910.2.2 This publication per SECTIONS:

101 Portland Cement Concrete

102 Steel Reinforcement

105 Concrete Curing Compound

106 Cement Mortar and Grout

108 Brick

123 Reinforced Concrete Pipe

124 Reinforced Concrete Pressure Pipe

125 Vitrified Clay Pipe

135 Corrugated Metal Pipe and Arches (Steel)

161 Gray Iron Castings

910.3 MATERIALS

910.3.1 Pipe: Storm sewer line pipe and fittings shall be as specified in other sections as follows:

Section 123 Reinforced Concrete Pipe

Section 124 Reinforced Concrete Pressure Pipe

Section 135 Corrugated Metal Pipe and Arches
Arches, and Pipe Arches

910.4 CERTIFICATION

The OWNER/ENGINEER will be supplied with a certification on each item or type of material required in the storm sewer line, as to that item meeting the specifications and/or the reference specifications before that item is installed.

910.5 INSTALLATION

910.5.1 GENERAL:

910.5.1.1 Pipe and appurtenances shall be new and unused. The type of pipe to be installed shall be as approved by these specifications or unless otherwise shown on the drawings. Pipe and appurtenances shall be handled in such a manner as to insure delivery to the trench in sound, undamaged condition. Particular care shall be taken to prevent damage to any pipe coating.

910.5.1.2 The interior of the pipe shall be thoroughly cleaned of foreign material before being lowered into the trench and shall be kept clean during construction operations. When work is not in progress, the open ends of pipe shall be securely closed so that no foreign materials will enter the pipe. Any section of pipe found to be defective before or after laying shall be replaced with sound pipe, or repaired in a manner satisfactory to the ENGINEER, without additional expense to the owner.

910.5.1.3 Pipe shall be laid to line and grade as shown on the plans and as staked in the field. The bottom of the trench shall be graded and prepared to provide a firm and uniform bearing and bedding throughout the entire length of the pipe barrel. Suitable excavation shall be made to receive the bell of the pipe and the joint shall not bear upon the bottom of the trench. All adjustment to the line and grade shall be made by scraping or filling in with pipe zone material under the body of the pipe, and not by wedging or blocking. When connections are to be made to any existing manhole, pipe, or other improvement, the actual elevation or position of which cannot be determined without excavation, the CONTRACTOR shall excavate for and expose the existing improvement before laying the connecting pipe or conduit. When existing underground improvements may reasonably be expected to conflict with the line or grade established for the new

SECTION 910

STORM SEWER PIPE INSTALLATIONS

sewer line, the ENGINEER shall request and the CONTRACTOR shall excavate as necessary to expose and locate such potentially conflicting underground improvements prior to laying the new pipe. Any adjustment in line or grade which may be necessary to accomplish the intent of the plans will be made, and the CONTRACTOR will be paid for any additional work resulting from such change in line or grade in the manner provided for in the General Conditions.

910.5.1.4 CONTRACTOR shall submit to the ENGINEER the proposed method for making connections to existing manholes. Connection methods will be dependent upon manhole size and pipe sizes. Unnecessary damage to the existing manhole should be avoided.

910.5.1.5 Pipe shall be laid upgrade in a continuous operation from structure to structure, with the socket or collar ends of the pipe upgrade unless otherwise permitted by the ENGINEER. Concrete pipe with elliptical reinforcement shall be laid with the minor axis of the reinforcement cage in a vertical position. Corrugated metal pipe shall be laid with the external laps of the circumferential seams toward the inlet end.

910.5.1.6 Pipe penetrations into manholes shall not extend more than 2" into the manhole. The penetration hole shall be cleaned. There shall be a concrete collar on the exterior side of the penetration, and the interior side shall be grouted around the pipe.

910.6 JOINTS FOR PIPE

910.6.1 JOINTS FOR CONCRETE PIPE:

910.6.1.1 The type of joint to be used shall be O-ring rubber gasket joints conforming to ASTM C 361 and C 443.

910.6.1.2 Gasketed Type of Joints for Reinforced Concrete Pipe

910.6.1.2.1 General – The ends of the pipe shall be so formed that when the pipes are laid together and joined, they shall make a continuous and uniform line of pipe with a smooth and regular surface. The maximum joint gap width shall conform to manufacturer's specifications.

910.6.1.2.2 Rubber gaskets for making compression-type joints for concrete pipe shall be factory

fabricated in accordance with ASTM C 443; for pipes 12 inches in diameter and larger shall be O-ring and shall be handled, primed, installed, etc. in strict accordance with the manufacturer's recommendations.

910.6.1.2.3 The CONTRACTOR'S attention is particularly called to ASTM C 443, regarding storage of gaskets.

910.6.1.2.4 The CONTRACTOR shall furnish the ENGINEER complete information concerning the type and make of all joint material which he intends to use under the contract, including certification that the joint material meets the requirements of the specifications.

910.6.2 JOINTS FOR CORRUGATED METAL PIPE:

910.6.2.1 The seams of the pipe are to be placed at the sides, not on the bottom. The inside circumferential seams should be placed pointing downstream. Care should be taken to insure that dirt or other particles do not get between the outside of the pipe and the pipe coupling. Paved inverts should be placed and centered on the bottom of the trench. Any damage to the protective lining and coating shall be repaired prior to the backfilling around the pipe.

910.6.2.2 If waterproof joints are called for on the plans or specified in the Supplementary Specifications, the caulking compound or other waterproofing material used shall be subjected to the approval of the ENGINEER.

910.6.3 POLYPROPYLENE PIPE

910.6.3.1 Pipe shall be joined using a bell and spigot joint meeting the requirements of ASTM F2881 or ASTM F27674. The joint shall be watertight according to the requirements of ASTM D3212. Gaskets shall meet the requirements of ASTM F477. The gasket shall be installed by the pipe manufacturer and covered with a removable, protective wrap to ensure the gasket is free from debris. A joint lubricant available from the manufacturer shall be used on the gasket and bell during assembly. 12 through 60 inch (300 to 1500 mm) diameters shall have an exterior bell wrap installed by the manufacturer.

910.7 TESTING FOR LEAKAGE

SECTION 910

STORM SEWER PIPE INSTALLATIONS

Normally storm sewer lines need not be tested, but if in the opinion of the ENGINEER, the workmanship or materials do not appear to be satisfactory, the ENGINEER may require that a section of the storm sewer line be tested in a similar manner as that for a sanitary sewer line, see Section 901.

910.8 CLEANING AND INSPECTION

910.8.1 CLEANING: No pipe spalls, rocks, dirt, joint compounds, cement mortar and other trash or obstructions shall be left in a storm sewer pipe of any size or type. During flushing operations the manhole outlet shall be bagged or plugged so that the debris will not be carried into an existing active line.

910.8.2 INSPECTION: Before lines become operational or final acceptance of the installation. Lines larger than 18" in diameter and longer than 30 feet in length shall be inspected using Closed Circuit Television Camera (CCTV). Joint gaps or cracks that are larger than the Manufacturer's tolerances will not be accepted. Water ponding in the pipe deeper than 1" will not be accepted, nor will pipes with insufficient slope.

910.8.3 CLOSED CIRCUIT TELEVISION (CCTV): After the CONTRACTOR has cleaned and flushed the line, the CONTRACTOR will notify the ENGINEER that the line is ready for television inspection. The video is to be submitted to the City Storm Drain Inspector for review. If corrections are necessary, a new television inspection is to be submitted for review after the corrections are made. The cost of the inspection is included in the price of the storm drain.

910.9 MEASUREMENT AND PAYMENT

910.9.1 STORM SEWER PIPE: Installed pipe shall be measured and paid for as follows:

910.9.1.1 For straight lines the pipe length shall be the intervening distance between the centers of manholes along a line parallel to the pipe invert.

910.9.1.2 For curvilinear lines the pipe length shall be the intervening arc distance between the centers of manholes along a line parallel to the pipe invert.

910.9.1.3 For lateral lines, such as from main or manhole to a storm inlet, the pipe length shall be the distance between the center of a manhole or

centerline of the main to the interior wall face of the storm inlet along a line parallel to the pipe invert.

910.9.1.4 Payment for pipe will be in accordance with the unit price per linear foot per size and material as defined in the Bid Proposal, and shall include pipe installed in the trench, jointing and coupling materials, and other materials necessary to connect to other sections of pipe, manholes, and other appurtenances.

910.9.2 REMOVAL AND DISPOSAL OF SEWER PIPE: Removal and disposal of storm sewer pipe shall be measured by the linear foot within the specified pipe size increments. Payment will be made on the unit price per linear foot of specified pipe size in the Bid Proposal. Trenching, backfilling, and pavement removal and replacement will be paid for based on the unit prices for each appropriate bid item in the Bid Proposal. If new pipe is to be installed in the same trench as the removed pipe, only one payment will be made for trenching, backfilling, and pavement removal and replacement.

910.9.3 TESTING OF PIPE: No payment will be made for required initial or subsequent tests on sections of the storm sewer line.

SECTION 912

POLYPROPYLENE PIPE FOR STORM SEWERS

912.1 GENERAL

Polypropylene storm sewer pipe may be used in the City's right-of-way and under pavements for roadway functional classifications collector or less. Applications with greater traffic counts will need approval by the City Engineer.

912.2 REFERENCES

912.2.1 ASTM

D2321 Underground Installation of Thermoplastic Pipe for Sewers and Other Gravity-Flow Applications

D3212 Joints for Drain and Sewer Plastic Pipes Using Flexible Elastomeric Seals

F477 Elastomeric Seals (Gaskets) for Joining Plastic Pipe

F2764 6 to 60 in. (150 to 1500 mm) Polypropylene (PP) corrugated Double and Triple Wall Pipe and fittings for Non-Pressure Sanitary Sewer Applications

F2881 12 to 60 in. (300 to 1500 mm) Polypropylene (PP) Dual wall Pipe and Fittings for Non-Pressure Storm Sewer Applications

D1557 Standard Test Methods for Laboratory Compaction Characteristics of Soil Using modified Effort (56,000 ft-lbf/ft³ (2,700 kN- m/m³))

912.2.2 This publication per SECTIONS:

701 -- Trenching, Excavation and Backfill

910 -- Storm Sewer Pipe Installations

912.3 MATERIALS

912.3.1 Delivery, Storage, and Handling -- All pipe and fittings shall be delivered to the site and unloaded with handling that conforms to the manufacturer's instructions for reasonable care. Pipe shall not be rolled or dragged over gravel or rock during handling. The Contractor shall take necessary precautions to ensure the method used in lifting or placing the pipe does not induce undue stress fatigue in the pipe.

912.3.2 Not used.

912.3.3 Six through 60-inch (150 through 1500 mm) pipe shall be polypropylene or pre-approved equal. Pipe supplied shall be with annular inner corrugations and smooth interior and exterior surfaces, corrugated polypropylene (PP) pipe meeting the requirements of ASTM F2764 for respective diameters. The pipe supplied shall be watertight as defined in the joint performance requirements of this specification.

912.3.4 The pipe supplied shall be watertight as defined in Section 912.6.3.

912.3.5 Virgin material for 12- through 60-inch pipe and fitting production shall be an impact modified copolymer meeting the material requirements of ASTM F2764 for respective pipe diameters.

912.3.6 Pipe stiffness - Minimum pipe stiffness at 5% deflection shall meet the requirements per ASTM F2764.

912.4 CERTIFICATION

The OWNER/ENGINEER will be supplied with a certification on each item or type of material required in the storm sewer line, as to that item meeting the specifications and/or the reference specifications before that item is installed.

912.5 INSTALLATION

912.5.1 Pipe and fittings shall be inspected prior to installation and any defective or damaged product shall be replaced. Any pipe or fittings with cuts, punctures, or other damage on the interior or exterior shall be rejected and replaced. Any pipe or fittings with damaged ends or joints, which would prevent proper sealing of the joints, shall be rejected and replaced.

912.5.2 All products shall be inspected for defects and cracks before being lowered into the trench, piece by piece. Any defective, damaged or unsound pipe or fittings, or any product that has had its grade disturbed after laying, shall be taken up and replaced. Open ends shall be protected with a pipe plug to prevent earth or other material from entering the pipe during construction. The interior of the pipe shall be free from dirt, excess water and other foreign materials as the pipe laying progresses and left clean at the completion of the installation.

912.5.3 Install piping system beginning at low point, true to grades and alignment indicated with unbroken continuity of invert. Place bell ends of piping facing upstream. Install gaskets, seals, sleeves, and

SECTION 912

POLYPROPYLENE PIPE FOR STORM SEWERS

couplings according to manufacturer's written instructions. Follow product manufacturer's instructions for the use of lubricants, cements, and other special installation requirements.

912.5.4 Do not lay or embed pipe or fittings in standing or running water. At all times prevent runoff and surface water from entering the trench.

912.5.5 When water is present in the work area, dewater to maintain stability of in-situ and imported materials. Maintain water level below pipe bedding and foundation to provide a stable trench bottom. Use, as appropriate, sump pumps, well points, deep wells, geofabrics, perforated underdrains, or stone blankets of sufficient thickness to remove and control water in the trench. When excavating while depressing ground water, ensure the ground water is below the bottom of cut at all times to prevent washout from behind sheeting or sloughing of exposed trench walls. Maintain control of water in the trench before, during, and after pipe system installation and until embedment is installed and sufficient backfill has been placed to prevent flotation of the pipe, fitting, or drainage structures. To preclude loss of soil support, employ dewatering methods that minimize removal of fines and the creation of voids in in-situ materials.

912.5.6 Rock in either ledge or boulder formation shall be replaced with suitable materials to provide a compacted earth cushion having a thickness between exposed rock and the pipe of at least 12 inches (0.3m). Where Bell-and-Spigot pipe is used, the cushion shall be maintained under the bell as well as under the straight portion of the pipe.

912.5.7 Where wet or otherwise unstable soil incapable of properly supporting the pipe system, as determined by the Engineer, is encountered in the bottom of a trench, such material shall be removed to at least 24 inches below bottom of pipe and replaced to the proper grade with select granular material, compacted as directed by the engineer. When removal of unstable material is due to the fault or neglect of the Contractor while performing shoring and sheeting, water removal, or other specified requirements, such removal and replacement shall be performed at no additional cost to the Owner.

912.5.8 A stable and uniform bedding shall be provided for the pipe and any protruding features of its joint and/or fittings. The middle of the bedding, equal to one-third of the pipe outside diameter, shall be loosely placed while the remainder shall be compacted to a minimum of 90% of maximum

density per ASTM D1557, or as shown in the plans. Pipe bedding shall be a minimum of 4" – 6" in thickness. The bedding surface for the pipe shall provide a firm foundation of uniform density throughout the entire length of the pipe.

912.5.9 Each pipe shall be thoroughly examined before being laid; defective or damaged pipe shall not be used. Pipelines shall be laid to the grades and alignment indicated. Proper facilities shall be provided for lowering sections of pipe into trenches. Pipe shall not be laid in water, and the pipe shall not be laid when trench conditions or weather are unsuitable for such work. Diversion of drainage or dewatering of trenches shall be provided as directed by the engineer; see dewatering section.

912.5.10 Class 1 or 2 backfill materials per ASTM D2321 may be used for the bedding, haunch, and initial backfill zones per the Standard Drawings. Class 3 backfill materials per ASTM D2321 may be used with pipes having a stiffness greater than 9 psi.

912.6 JOINTS FOR PIPE

912.6.1 All pipe supplied shall meet the minimum joint performance requirements as defined herein and as further defined in the joint performance requirements of this specification.

912.6.2 Watertight joints shall be bell-and-spigot and gaskets shall be made of polyisoprene meeting the requirements of ASTM F477.

912.6.3 Pipe shall meet the minimum joint performance requirements per ASTM D3212, a 10.8 psi gage (104kPa) laboratory pressure test for 10 minutes with no visible leaks at the joint. Piping shall pass same tests as above but with an axial joint misalignment of not less than 1 degree.

912.6.4 All Bell-and-Spigot pipe joints shall be thoroughly cleaned. Joint lubricant, supplied by the manufacturer, shall be liberally applied to entire interior of bell and gasket on spigot prior to assembly.

912.7 BACKFILLING

912.7.1 General: Backfill placement and compaction shall be constructed in accordance with the specifications herein and the product manufacturer's published installation guides.

912.7.2 Backfilling Pipe in Trenches: After the pipe and pipe system have been properly bedded, selected

SECTION 912

POLYPROPYLENE PIPE FOR STORM SEWERS

material from excavation or borrow, at a moisture content that will facilitate compaction, shall be placed along both sides of pipe in layer depths to ensure minimum compaction density is obtained evenly throughout the backfill material. The backfill shall be brought up evenly on both sides of pipe and pipe system for the full length of pipe. The fill shall be thoroughly compacted under the haunches of the pipe. Each layer shall be thoroughly compacted with mechanical tampers or rammers. This method of filling and compacting shall continue until the fill has reached the top of the pipe. The remainder of the trench shall be backfilled and compacted by spreading and rolling or compacted by mechanical rammers or tampers. Tests for density shall be made as necessary to ensure conformance to the compaction requirements specified below.

912.7.3 Backfilling Pipe in Fill Sections: For pipe placed in fill sections, fill shall be constructed to at least 6 inches above the top of proposed pipe prior to trench excavation. Fill shall be placed in 12 inch lifts and shall be compacted to achieve 90% of maximum density (per ASTM D1557), or as shown on plans. Once fill is placed and compacted pipe trench shall be constructed in accordance with the Trench Excavation section of this specification.

912.7.4 Movement of Construction Machinery: When compacting by rolling or operating heavy equipment parallel with the pipe, displacement of or injury to the pipe shall be avoided. Movement of construction machinery over a culvert or storm drain at any stage of construction shall be at the Contractor's risk. Any damaged pipe shall be repaired or replaced.

912.7.5 Compaction

912.7.5.1 General Requirements: Non-cohesive materials include gravels, gravel-sand mixtures, sands, and gravelly sands. Cohesive materials include clayey and silty gravels, gravel-silt mixtures, clayey and silty sands, sand-clay mixtures, silts, and very fine sands. When results of compaction tests for moisture-density relations are recorded on graphs, non-cohesive soils will show straight lines or reverse-shaped moisture-density curves, and cohesive soils will show normal moisture-density curves.

912.7.5.2 Minimum Density: Backfill over and around the pipe and backfill around and adjacent to drainage structures shall be compacted at the approved moisture content to the following applicable minimum density, which will be

determined as specified below. Compaction shall be to a density of not less than 90% of maximum density, as determined by ASTM D 1557. The moisture content shall not exceed 5 percent above optimum

912.7.6 Determination of Density: Testing shall be performed by an approved commercial testing laboratory or by the Contractor subject to approval by the Engineer. Tests shall be performed in sufficient number to ensure that specified density is being obtained. Laboratory tests for moisture-density relations shall be made in accordance with ASTM D1557 except that mechanical tampers shall be used provided the results are correlated with those obtained with the specified hand tamper. Field density tests shall be determined in accordance with ASTM D2167 or ASTM D2922. Test results shall be furnished to the Engineer.

912.8 TESTING FOR LEAKAGE

Normally storm sewer lines need not be tested, but if in the opinion of the ENGINEER, the workmanship or materials do not appear to be satisfactory, the ENGINEER may require that a section of the storm sewer line be tested in a similar manner as that for a sanitary sewer line, see Section 901.

912.9 CLEANING AND INSPECTION

912.9.1 CLEANING: No pipe spalls, rocks, dirt, joint compounds, cement mortar and other trash or obstructions shall be left in a storm sewer pipe of any size or type. During flushing operations the manhole outlet shall be bagged or plugged so that the debris will not be carried into an existing active line.

912.9.2 INSPECTION: Before lines become operational or final acceptance of the installation, small size lines shall be inspected by a television camera and larger size lines will be inspected by walking through the line.

912.9.3 TELEVISION: After the CONTRACTOR has cleaned and flushed the line, the CONTRACTOR will notify the ENGINEER that the line is ready for television inspection. Prior to the television inspection (possibly during flushing operation) the CONTRACTOR will insert a ¼ inch nylon rope in the line for the purpose of towing the television unit through the pipe. The OWNER will perform the first television inspection at no cost to the CONTRACTOR. If during the first inspection debris is found in the line, the television inspection will cease. When further cleanup has been completed, the

SECTION 912

POLYPROPYLENE PIPE FOR STORM SEWERS

CONTRACTOR will request the ENGINEER to have a second inspection performed. The cost of the second inspection and any subsequent inspections of that segment of the line will be paid for by the CONTRACTOR at the rate of \$50.00 per hour while the television crew is at the line site.

912.10 MEASUREMENT AND PAYMENT

912.10.1 STORM SEWER PIPE: Installed pipe shall be measured and paid for as follows:

912.10.1.1 For straight lines the pipe length shall be the intervening distance between the centers of manholes along a line parallel to the pipe invert.

912.10.1.2 For curvilinear lines the pipe length shall be the intervening arc distance between the centers of manholes along a line parallel to the pipe invert.

912.10.1.3 For lateral lines, such as from main or manhole to a storm inlet, the pipe length shall be the distance between the center of a manhole or centerline of the main to the interior wall face of the storm inlet along a line parallel to the pipe invert.

912.10.1.4 Payment for pipe will be in accordance with the unit price per linear foot per size and material as defined in the Bid Proposal, and shall include pipe installed in the trench, jointing and coupling materials, and other materials necessary to connect to other sections of pipe, manholes, and other appurtenances.

912.10.2 REMOVAL AND DISPOSAL OF SEWER PIPE: Removal and disposal of storm sewer pipe shall be measured by the linear foot within the specified pipe size increments. Payment will be made on the unit price per linear foot of specified pipe size in the Bid Proposal. Trenching, backfilling, and pavement removal and replacement will be paid for based on the unit prices for each appropriate bid item in the Bid Proposal. If new pipe is to be installed in the same trench as the removed pipe, only one payment will be made for trenching, backfilling, and pavement removal and replacement.

912.10.3 TESTING OF PIPE: No payment will be made for required initial or subsequent tests on sections of the storm sewer line.

SECTION 915

STORM SEWER DRAINAGE APPURTENANCES

915.1 GENERAL – The construction items, specified in this section, are related to the storm sewer underground facilities.

915.2 REFERENCES

915.2.1 This publication:

SECTION 300 Streets and Related Work

SECTION 501 Excavation and Backfill for Structures

SECTION 701 Trenching, Excavation and Backfill

915.3 MATERIALS

915.3.1 The construction plans will specify the size and material for the pipe between the storm sewer main and the storm water collection structure.

915.3.2 The various types of storm inlets and their relation to curb and gutter, or valley gutter are shown in the Standard Detail Drawings. Construction plans will identify the type to be constructed.

915.3.3 Grating size, material, and configuration shall conform to the Standard Detail Drawings.

915.4 INSTALLATION OF DRAINAGE FACILITIES

915.4.1 Excavation and backfilling for the storm inlet shall be accomplished in accordance with Section 501.

915.4.2 Trenching, backfilling, and compaction for the connecting pipe between the storm sewer main and the storm inlet shall conform to the specification contained in Section 701. Pipe shall be installed in accordance with Section 910.

915.4.3 All pipe and structures shall be installed per location and elevations, as shown on the construction plans. If during the course of installation, an underground obstruction (i.e., existing utility line) the work shall stop and the ENGINEER shall be immediately notified so that the problem can be resolved.

915.4.4 Direct connection to storm sewer main will be permitted if the main is a minimum of 36 inches in diameter (I.D.) and the connecting line is not greater than 12 inches (I.D.). If storm sewer mains are 48 inches (I.D.) or larger, the connecting line diameter may be increased to 18 inches (I.D.). For connecting

line sizes greater than those specified above, the connection to the main will be made into a manhole or by inserting into the main a factory constructed wye. Connection to the main will comply with the Standard Detail Drawings.

915.4.5 Removal of curb and gutter, and sidewalk for installation of a storm inlet shall be made at a scored or full depth joint.

915.4.6 Existing pavement removal and replacement shall conform to Sections 343 and shall conform to residential or arterial pavement sections of the same material (asphalt or Portland Cement concrete) as the existing pavement.

915.4.7 No width greater than ½ inch will be permitted between the inlet grate and the roadside portion of the inlet frame.

915.5 Private drainage facility installations, which are to be constructed under the authorization of “Drainage Facilities Within Public Right-of Way,” shall comply with the Standard Detail Drawings and appropriate sections of this publication.

915.6 MEASUREMENT AND PAYMENT

915.6.1 Pavement removal and replacement will be measured by square yard. Payment will be made at the unit price per square yard per type of replacement paving material, as specified in the Bid Proposal.

915.6.2 Trenching, backfilling, and compaction shall be measured by the linear foot from the main side wall of the inlet to the centerline of the main. Payment will be made at the unit price per linear foot per the average depth increment between connection points, as defined in the Bid Proposal.

915.6.3 Connecting pipe shall be measured by the linear foot along centerline of pipe from the main side wall of the inlet to the centerline of the main. Payment will be made at the unit price per linear foot per type and size of pipe, and shall include pipe in place and all necessary jointing materials.

915.6.4 Storm inlets shall be measured on a unit basis. Payment will be made at the unit price per each type of storm inlet, and shall include structure, grating, excavation, backfilling and compaction, and curb removal and replacement, as defined in Bid Proposal.

SECTION 915

STORM SEWER DRAINAGE APPURTENANCES

915.6.5 Removal and replacement of sidewalk shall be measured by the square foot and payment will be made at the unit price per square foot.

SECTION 920

SANITARY SEWER MANHOLES

920.1 GENERAL: This section contains items which are relative to the installation and rehabilitation of sanitary sewer manholes.

920.2 REFERENCES

920.2.1 ASTM

C 32 Standard Specification for Sewer and Manhole Brick (Made From Clay or Shale)

C 139 Standard Specification for Concrete Masonry Units for Construction of Catch Basins and Manholes

C 478 Standard Specification for Precast Reinforced Concrete Manhole Sections

C 497 Standard Test Methods for Concrete Pipe, Manhole Sections, or Tile

D 1557 Standard Test Methods for Laboratory Compaction Characteristics of Soil Using Modified Effort

920.2.2 This publication:

SECTION 101	PORTLAND CEMENT CONCRETE
SECTION 102	STEEL REINFORCING
SECTION 105	CONCRETE CURING COMPOUND
SECTION 106	CEMENT MORTAR AND GROUT
SECTION 108	BRICK
SECTION 161	GRAY IRON CASTINGS
SECTION 163	DUCTILE IRON CASTINGS
SECTION 170	ELECTRONIC MARKER DEVICES

920.3 MATERIALS

920.4 SANITARY SEWER MANHOLE CONSTRUCTION

920.4.1 GENERAL

920.4.1.1 Soil Foundations for manhole base shall be compacted to a density of 95 percent of the maximum density per ASTM D 1557. Compaction limits shall be one foot beyond the perimeter of the concrete base and shall be a minimum of one foot in depth.

920.4.1.2 Manholes shall be constructed in accordance with the Standard Detail Drawings and as shown on the construction plans. Precast reinforced concrete units, concrete blocks or formed in-place, reinforced concrete may be used to construct manhole.

920.4.1.3 Invert elevation of the pipes entering or exiting the manhole and interior inverts shall not vary more than 0.05 feet from the elevation indicated on the construction plans. In order to ensure compliance with the design drawings, the CONTRACTOR shall provide the ENGINEER with coordinates, obtained by a Professional

Surveyor licensed in the state of New Mexico. The vertical precision of the coordinates shall be, at a minimum, accurate to within 0.05 feet. Use the NAD 1983 NM STATE PLANE CENTRAL ZONE for x and y coordinates and NAVD 1988 for z coordinate.

920.4.1.4 All cement used for poured foundations, mortar, fillets, grout, and concrete shelf construction shall be Type II or approved equal.

920.4.1.5 All concrete for formed in place foundations or bases, concrete shelves, and pipe supports shall conform to Section 101.

920.4.1.6 Depending on the size of the pipe, connections to existing and new manholes shall be made by either core drilling through the manhole wall, preformed for new precast units, or for large-size pipe the manhole wall may be removed by carefully chipping the wall segment which will permit entry of the pipe. In the latter operation, exposed manhole reinforcement should be bent and tied to the reinforcement of the pipe tied to the reinforcement of the pipe collar. If core drilling is not practical, the CONTRACTOR shall request the ENGINEER to authorize the chipping operation. During either operation the CONTRACTOR shall take care to avoid unnecessary damage to the manhole surfaces or walls.

920.4.1.7 Electronic marker devices shall be installed at all sanitary sewer manholes, one foot upstream of the manhole over the centerline of the main line as specified in Section 170.

920.4.2 PRECAST CONCRETE MANHOLES:

920.4.2.1 The vertical sections of the manhole may be of different dimensions in order that manholes of various depths can be readily assembled.

920.4.2.2 Concrete, used for precast bases, vertical sections, and concentric cones, shall conform to Section 101.

920.4.2.3 Vertical sections of the manhole shall conform to the requirements of ASTM C 478.

920.4.2.4 The CONTRACTOR shall submit shop drawings of the precast base and concentric cone to the ENGINEER for review and approval.

920.4.2.5 Circular precast manhole sections shall be provided with mastic gasket to seal joints between sections. Material used shall conform to the Water Authority Approved Product List.

920.4.2.6 All lifting holes, except Type "C" manhole covers, and gaps at joints shall be filled with a non-shrink grout.

SECTION 920

SANITARY SEWER MANHOLES

920.4.2.7 Precast concrete manhole bases may be used when approved by the ENGINEER. If approved, it shall be with the understanding that the CONTRACTOR shall be responsible for placing the bases at the specified elevation, location, and alignment.

920.4.3 FORMED-IN-PLACE REINFORCED CONCRETE MANHOLE:

920.4.3.1 The CONTRACTOR shall submit preconstruction drawings of the proposed manholes to the ENGINEER for review and approval.

920.4.3.2 Concrete used for this type of manhole construction shall conform to Section 101.

920.4.3.3 If desired, a precast concentric cone or a flat top cover can be used.

920.4.4 CONCRETE BLOCK MANHOLE:

920.4.4.1 The CONTRACTOR shall submit preconstruction drawings of the proposed manhole to the ENGINEER for review and approval.

920.4.4.2 Concrete masonry units for the construction of this type of manhole shall conform to ASTM C 139 and the Standard Detail Drawings. All blocks shall be mortared into place.

920.4.4.3 Concentric cone or flat top cover shall be used.

920.4.5 (intentionally left blank)

920.4.6 COATING OF MANHOLES:

920.4.6.1 Exterior of Manholes: Exterior coating of manholes shall be required in areas where ground water is present. The coating shall be a waterproofing type of bitumastic or asphaltic material, as approved by the ENGINEER. Application shall be in accordance with the manufacturer's published recommendations.

920.4.6.2 Interior of Manholes: Interior coating of manholes shall be required only when specified on the construction plans. The coating shall be an epoxy resin-type material, listed on the Water Authority Approved Product List, and shall be capable of protecting the concrete from deterioration due to a gaseous environment. Application shall be in accordance with the manufacturer's published recommendations.

920.4.6.3 Plastering of Manholes: The work shall include the coating of the surface of existing block manholes with plaster as required on the construction plans.

920.4.7 (intentionally left blank):

920.4.8 ADJUSTMENT BRICKS:

920.4.8.1 Manhole adjustment bricks shall conform to the requirements for manhole bricks, per ASTM C 32 for Grade MS.

920.4.8.2 Mortar shall be used to lay the bricks, as well as coating the interior and exterior surfaces of the laid brick. Thickness of the mortar coating shall be ½-inch.

920.4.9 MANHOLE FRAME AND COVER:

The manhole frame and cover for the sanitary sewer shall conform to the specifications contained in Section 163 Ductile Iron Castings.

920.5 LEAKAGE TESTING OF SEWER MANHOLES:

920.5.1 All sanitary sewer manholes shall be tested for leakage by either a water exfiltration test or a vacuum test. Whichever leakage test is utilized, it is recommended that the test be performed prior to backfilling around the manhole and prior to placement of the manhole frame and cover. All inlet and outlet lines shall be properly plugged and the lift holes and barrel joints filled and sealed as specified. The CONTRACTOR shall be responsible for all materials and equipment necessary to perform the test and shall conduct the test in the presence of the ENGINEER or his representative. The CONTRACTOR has the option of performing a manhole test in increments appropriate to the depth of the manhole.

920.5.1.1 Under all circumstances, the CONTRACTOR shall be required to remove all plugs immediately after testing and prior to acceptance of the work. The Water Authority assumes no liability for damages caused by plugs inadvertently left in the line by the Contractor. The CONTRACTOR shall certify in writing to the Water Authority the completion of the plug removal task. The certification shall include the locations of removed plugs and corresponding date of removal.

920.5.2 The water exfiltration test shall consist of filling the entire manhole with water to the bottom of the frame elevation. A stabilization period of one hour will be allowed for absorption, after which the manhole shall be refilled as necessary before starting the test. The test period shall be two (2) hours, after which the manhole shall be refilled, measuring the necessary quantity of water. The allowable leakage shall be 0.25 gallons per foot diameter per vertical foot per day and is represented by the following formula:

$$V = 0.25 \text{ DHT} / 24$$

Where: V = Allowable loss in gallons
D = Manhole diameter in feet
H = Initial depth of water to invert in feet
T = Duration of test in hours

SECTION 920

SANITARY SEWER MANHOLES

920.5.3 The vacuum test shall consist of utilizing an inflatable compression band, vacuum pump, gauges and appurtenances specifically designed for vacuum testing. Test procedures shall be in accordance with the manufacturer's printed recommendations. The ENGINEER shall be the sole judge as to the adequacy of the equipment.

920.5.3.1 A vacuum of 10" Hg shall be placed in the manhole and the time measured for a drop to 8.5" Hg. The test shall be considered to be successful if the measured time exceeds the test period. Should the test fail, the manhole shall be repaired as necessary and the test rerun. The test periods are:

920.5.3.2 Sixty (60) seconds for four (4) foot diameter manholes

920.5.3.3 Seventy-five (75) seconds for five (5) foot diameter manholes

920.5.3.4 Ninety (90) seconds for six (6) foot diameter manholes

920.5.3.5 One hundred and twenty (120) seconds for eight (8) foot diameter manholes

920.6 ABANDONMENT OF MANHOLES

920.6.1 Abandonment of manhole, which is part of a sewer line being abandoned, shall require the following work and materials:

920.6.2 Manhole will not be removed but will be abandoned in place.

920.6.3 All manhole inlet and outlet lines shall be plugged with a 12-inch thick concrete or concrete mortar plug.

920.6.4 The concrete collar, ring, and cover shall be removed and disposed of by the CONTRACTOR.

920.6.5 Manhole bottom will be pulverized.

920.6.6 The manhole shall be filled with cement treated base (CTB) material to the bottom elevation of the asphalt base course of the pavement or to the ground surface level.

920.6.7 All labor, materials, and equipment necessary to complete this work shall be furnished by the CONTRACTOR.

920.6.8 For historical information the ENGINEER shall provide coordinates accurate to within 0.3 feet, obtained by a Professional Surveyor licensed in the state of New Mexico, on the record drawings. Use the NAD 1983 NM STATE PLANE CENTRAL ZONE for x and y coordinates and NAVD 1988 for z coordinate.

920.7 SANITARY SEWER MANHOLE REHABILITATION

920.7.1 GENERAL

920.7.1.1 Sanitary sewer manhole rehabilitation shall include coating of manholes with a cementitious liner, rebuilding of manhole invert benches to the profile shown on Standard Drawings 2101 and 2102 or to the specific profiles provided on the construction plans, and installation of protective epoxy or polyurethane coating systems. Where shown on the construction plans, sanitary sewer manhole rehabilitation shall also include miscellaneous structural modifications including installation of 30-inch diameter opening with approved manhole cover and frame, and installation of new concrete collar.

920.7.2 SANITARY SEWER MANHOLE REHABILITATION ASSOCIATED WITH TRENCHLESS REHABILITATION WORK

920.7.2.1 This specification shall govern all work, materials, and equipment required for new manhole lining or manhole rehabilitation for the purpose of eliminating infiltration, providing corrosion protection, repair of voids, and restoration of the structural integrity of the manhole as a result of applying a monolithic fiber-reinforced cementitious liner to the wall and bench surfaces of brick, concrete, or any other construction material followed by a protective epoxy or polyurethane coating system, where specifically required on the construction plans.

920.7.2.2 For sliplining and cured-in-place pipe technologies where no point of intersection occurs in the manhole, the sewer liner may be installed continuous through the manhole. If installed in this manner, the portion within the manhole shall be neatly cut out and removed, and terminations sealed per liner manufacturer's recommendation. For those manholes where point of intersections occur in the manholes, the sewer liner shall be terminated and sealed per liner manufacturer's recommendation at the inside wall of the manhole. For those sewer rehabilitation methods that require annular grouting, a bulkhead shall be installed. The manhole shall be thoroughly cleaned using a high pressure washing system as recommended. A new bench shall be constructed to the pipe soffit and the manhole wall sealed with a monolithic, cementitious liner followed by application of a protective epoxy or polyurethane coating system.

920.7.2.3 Described are procedures for manhole preparation, cleaning, application and testing. The applicator, approved and trained by the manufacturer, shall furnish all labor, equipment and materials for applying a cementitious mix to form a monolithic liner of minimum 1/2-inch thickness using a machine specially designed for the application.

SECTION 920

SANITARY SEWER MANHOLES

920.7.2.3.1 All aspects of the installation shall be in accordance with the manufacturer's recommendations and with the following specifications which include: Elimination of all infiltration prior to making the application; Repair and sealing the invert benches; Removal of any loose and unsound material; Re-building of manhole invert benches to the pipe soffit; Spray application of a cementitious liner mix to form a monolithic liner; and Spray application of a protective epoxy or polyurethane liner system.

920.7.3 MATERIALS

920.7.3.1 All materials used shall be listed on the Water Authority Approved Product list.

920.7.3.1.1 Patching Mix: a quick setting fiber reinforced, calcium aluminate, corrosion resistant cementitious material shall be used as patching material to fill large voids.

920.7.3.1.2 Infiltration Control: a rapid setting cementitious product specifically formulated for leak control shall be used to stop minor water infiltration of water into the manhole.

920.7.3.1.3 Grouting Mix: a cementitious grout shall be used for stopping active infiltration into the manhole and filling voids in the manhole wall. Chemical grouts may be used to stop excessively active infiltration.

920.7.3.1.4 Cementitious Liner Mix: shall be used to form the monolithic liner covering all interior manhole surfaces. The liner mix shall be made with calcium aluminate cement or other approved corrosion preventative admixture and shall be applied according to the manufacturer's recommendations.

920.7.3.1.5 Protective Epoxy or Polyurethane Liner: shall be used to resist chemical attack and deterioration of the manhole walls.

920.7.4 SUBMITTALS AND CERTIFICATIONS

920.7.4.1 Before commencing work, the CONTRACTOR shall submit the following for Approval:

920.7.4.1.1 Technical Data Sheets for proposed materials.

920.7.4.1.2 Certifications that the proposed materials meet or exceed the requirements listed in the Specifications.

920.7.4.1.3 Installation procedures as recommended by the manufacturer.

920.7.4.1.4 Product testing results.

920.7.4.1.5 Design calculations.

920.7.4.1.6 Applicator qualifications and proof of manufacturer training.

920.7.5 APPLICATION

920.7.5.1 PREPARATION, CLEANING, AND LEAK PREVENTION

920.7.5.1.1 Place covers over sewer invert to prevent extraneous material from entering the lines.

920.7.5.1.2 All foreign material, deposits, and other contaminants shall be removed from the manhole wall and bench using a high pressure washer or water sprayer having a minimum nozzle discharge pressure of 1,200 psi. Care shall be taken not to cause additional damage to the manhole structure resulting from overpressure used in cleaning process.

920.7.5.1.2.1 Loose and protruding brick, mortar, and concrete shall be removed using a mason's hammer and chisel and/or scraper.

920.7.5.1.2.2 Large voids shall be filled with quick setting patching mix.

920.7.5.1.2.3 Active leaks shall be stopped using quick setting specially formulated mixes according to the manufacturer's recommendations.

920.7.5.1.2.4 Existing manhole steps or ladders shall be removed by cutting off flush to the manhole wall prior to application of any rehabilitation coatings.

920.7.5.2 INVERT REPAIR

920.7.5.2.1 Invert Repair shall be performed on all inverts with visible damage, where infiltration is present, or when vacuum testing is specified.

920.7.5.2.2 After blocking flow through the manhole and thoroughly cleaning the invert, the quick setting patch material shall be applied to the invert and bench. The material shall be troweled uniformly onto the damaged invert at a minimum thickness of ½-inch at the invert extending out onto the bench of the manhole sufficiently to tie into the structurally enhanced monolithic liner.

920.7.5.2.3 The finish invert surfaces shall be smooth and free of ridges and shall be tapered at the inlets and outlet of the channel for flow.

920.7.5.3 MIXING LINER MATERIALS

920.7.5.3.1 The material shall be mixed per the manufacturer's recommendations at a rate to allow for continuous spraying without interruption until each application is complete.

SECTION 920

SANITARY SEWER MANHOLES

920.7.5.3.2 If ambient temperatures are in excess of 95° F, precautions shall be taken to keep the mix temperature at time of application below 90° F. If necessary, use ice or chilled water during mixing.

920.7.5.4 SPRAYING LINER MATERIALS

920.7.5.4.1 Prior to spraying, the surface shall be clean and free of all foreign material and shall be damp without noticeable free water droplets or running water. Materials shall be applied by spraying a minimum uniform thickness to ensure that all cracks, crevices, and voids are filled and a smooth surface remains after light troweling. The troweling shall compact the material into voids and set the bond.

920.7.5.4.2 Material shall not be applied to frozen surfaces or if freezing is expected to occur within the manhole for 24 hours after application.

920.7.5.4.3 The second application of material shall not begin before the first application has achieved an initial set. The minimum total finished thickness of cementitious material shall not be less than 1/2 inch. The second application shall be trowelled to a smooth finish being careful not to over trowel and to bring additional water to the surface thereby weakening it.

920.7.5.4.4 Ambient manhole conditions are adequate for curing so long as the manhole is covered. It is imperative that the manhole be covered as soon as possible after the application has been completed.

920.7.5.4.5 Contractor shall protect surfaces from contamination of any type between coats and through curing periods.

920.7.5.4.6 Epoxy or polyurethane liner systems shall be applied to a dry film thickness no less than 125 mils excluding any primer coats required by the manufacturer.

920.7.5.4.7 Active flows shall not be introduced through the manhole until the manufacturer's recommended cure time for the product's final coat has been achieved.

920.7.5.5 CONSTRUCTION DEBRIS CONTROL

920.7.5.5.1 The manhole cover shall remain in place except when necessary, .e.g. replacement or adjustment of the ring and cover.

920.7.5.5.2 Where the cover must be removed, the Contractor shall submit a written plan (Debris Control Plan) to control debris to the ENGINEER for approval. The plan shall be a submittal and contain:

920.7.5.5.2.1 Plan for preventing debris from entering the open manhole. Examples are a steel plate covering the open manhole or installation of a sturdy net.

920.7.5.5.2.2 Communication plan. Identify who is responsible for enforcing the Plan to all parties, including sub-contractors, working at the project site.

920.7.5.5.3 No additional payment will be made for the Debris Control Plan.

920.7.6 TESTING AND INSPECTION

920.7.6.1 A visual inspection of the manhole shall be performed to evaluate workmanship of the coating application

920.7.6.2 The cementitious materials used shall be compression strength tested as described in ASTM C39. The Contractor shall provide at least two (2) cylinders of material for testing, each 3 inch diameter x 6 inch long.

920.7.6.3 All manholes shall be tested per Section 920.5 of this Specification.

920.7.6.4 If requested by the Water Authority or Engineer, a Spark test shall be performed to ensure that there is a full monolithic lining and to ensure that there are no pinholes in the coating.

920.7.6.5 If requested by the Water Authority or the Engineer due to concerns regarding delamination or disbanding of the coating resulting from the integrity of the substrate under the coating, the strength of the substrate, or the contamination of substrate, a Pull Test shall be required.

920.8 MEASUREMENT AND PAYMENT

920.8.1 NEW MANHOLES:

920.8.1.1 Type "C" or "E" manholes of 4-foot, 6-foot, and 8-foot diameters shall be measured per each within the following increments of depth: 3 to 6 feet, 6 to 10 feet, and 10 to 14 feet. Manholes greater than 14 feet deep shall be measured and paid per Section 9.8.1.2. Measurements will be made to the nearest foot and will be from the manhole rim elevation to the manhole invert elevation.

920.8.1.2 Payment for manholes 14 feet deep or less will be made on the unit price per manhole diameter per depth increment as specified in the Bid Proposal. Payment for manhole depths which exceed 14 feet will be made on the unit price per manhole diameter per vertical foot. This payment is in addition to the manhole unit price for the portion above the 14 foot depth.

920.8.1.3 Payment for any type diameter or depth of manhole will include excavation, compacted backfilling, benching, cover or cone, leveling bricks, frame and cover, concrete pad or collar, and placement of EMD for sanitary sewers.

SECTION 920

SANITARY SEWER MANHOLES

920.8.2 ELEVATION ADJUSTMENTS:

920.8.2.1 When a new manhole is installed, no measurement or payment will be made for rim elevation adjustments to conform to street surface grades.

920.8.2.2 The following measurements and payments for rim elevation adjustments on existing manholes will be made for indicated conditions:

920.8.2.2.1 Unit price per inch of leveling brick adjustment.

920.8.2.2.2 Unit price per manhole diameter per vertical foot of adjustment to cone and/or barrel.

920.8.2.3 As required, the following items will be included in the unit price per appropriate adjustment: pavement removal and replacement, excavation, compacted backfilling, reinforced concrete collar or pad, leveling bricks, frame, cover, and EMD placement.

920.8.3 EXTERIOR COATING OF MANHOLE:

Exterior waterproof coating for manholes shall be measured and paid for on the unit price per square foot of surface area covered.

920.8.4 INTERIOR COATING OF MANHOLE:

Plastering or epoxy coating for manholes shall be measured and paid for on the unit price per square foot of surface area covered.

920.8.5 ABANDONMENT OF MANHOLES:

Measurement and payment for abandonment of a manhole shall be the unit price per manhole for defined work in Subsection 920.6.

920.8.6 MANHOLE REHABILITATION IN REPLACEMENT WORK: Work under this item shall be measured and paid for by the unit price per manhole for work specified in the Bid Proposal.

920.8.7 TESTING: There will be no payment for required testing of sewer manholes.

SECTION 921

STORM MANHOLES

921.1 GENERAL: This section contains items which are relative to the installation of storm manholes.

921.2 REFERENCES

921.2.1 ASTM

C 43 Standard Terminology of Structural Clay Products

C 139 Standard Specification for Concrete Masonry Units for Construction of Catch Basins and Manholes

C 478 Standard Specification for Precast Reinforced Concrete Manhole Sections

C 497 Standard Test Methods for Concrete Pipe, Manhole Sections, or Tile

C 1557 Standard Test Method for Tensile Strength and Young's Modulus of Fibers

921.2.2 This publication:

SECTION 101 PORTLAND CEMENT CONCRETE

SECTION 102 STEEL REINFORCING

SECTION 105 CONCRETE CURING COMPOUND

SECTION 106 CEMENT MORTAR AND GROUT

SECTION 161 GRAY IRON CASTINGS

921.3 MANHOLE MATERIALS

Storm manhole materials shall be as specified in other sections, as follows:

Portland Cement Concrete	Section 101
Steel Reinforcing	Section 102
Concrete Curing Compound	Section 105
Cement Mortar and Grout	Section 106
Gray Iron Castings	Section 161

921.4 MANHOLE CONSTRUCTION

921.4.1 GENERAL

921.4.1.1 Soil Foundations for manhole base shall be compacted to a density of 95 percent of the maximum density per ASTM D 1557. Compaction limits shall

be one foot beyond the perimeter of the concrete base and shall be a minimum of one foot in depth.

921.4.1.2 Manholes shall be constructed in accordance with the Standard Detail Drawings and as shown on the construction plans. Precast reinforced concrete units, concrete blocks or formed in-place, reinforced concrete may be used to construct manhole.

921.4.1.3 Invert elevation of the pipes entering or exiting the manhole and interior inverts shall not vary more than 0.05 foot from the elevation indicated on the construction plans.

921.4.1.4 All cement used for poured foundations, mortar, fillets, grout, and concrete shelf construction shall be Type II or approved equal.

921.4.1.5 All concrete for formed in place foundations or bases, concrete shelves, and pipe supports shall be 3000 psi compressive strength concrete.

921.4.1.6 Depending on the size of the pipe, connections to existing and new manholes shall be made by either core drilling through the manhole wall, performed for new precast units, or for large-size pipe the manhole wall may be removed by carefully chipping the wall segment which will permit entry of the pipe. In the latter operation, exposed manhole reinforcement should be bend and tied to the reinforcement of the pipe tied to the reinforcement of the pipe collar. If core drilling is not practical, the CONTRACTOR shall request the ENGINEER to authorize the chipping operation. During either operation the CONTRACTOR shall take care to avoid unnecessary damage to the manhole surfaces or walls.

921.4.2 PRECAST CONCRETE MANHOLES:

921.4.2.1 The vertical sections of the manhole may be of different dimensions in order that manholes of various depths can be readily assembled.

921.4.2.2 Concrete, used for precast bases, vertical sections, and eccentric cones, shall be 4000 psi compressive strength concrete.

921.4.2.3 Vertical sections of the manhole shall conform to the requirements of ASTM C 478

SECTION 921

STORM MANHOLES

921.4.2.4 The CONTRACTOR shall submit shop drawings of the precast base and eccentric cone to the ENGINEER for review and approval.

921.4.2.5 Circular precast manhole sections shall be provided with mastic gasket to seal joints between sections and apply non-shrink grout to exterior and interior of joints, or use watertight rubber gaskets. If rubber gaskets are used the manhole sections do not need to be grouted but the manufacturer must stamp the interior of each precast section with the type of gasket used.

921.4.2.6 All lifting holes, except Type "C" manhole covers, and gaps at joints shall be filled with a non-shrink grout.

921.4.2.7 Precast concrete manhole bases may be used when approved by the ENGINEER. If approved, it shall be with the understanding that the CONTRACTOR shall be responsible for placing the bases at the specified elevation, location, and alignment.

921.4.3 FORMED INPLACE REINFORCED CONCRETE MANHOLE:

921.4.3.1 The CONTRACTOR shall submit preconstruction drawings of the proposed manholes to the ENGINEER for review and approval.

921.4.3.2 Concrete used for this type of manhole construction shall be 4000 psi compressive strength concrete.

921.4.3.3 If desired, a precast eccentric cone or a flat cover can be used.

921.4.4 CONCRETE BLOCK MANHOLE:

921.4.4.1 The CONTRACTOR shall submit preconstruction drawings of the proposed manhole to the ENGINEER for review and approval.

921.4.4.2 Concrete masonry units for the construction of this type of manhole shall conform to ASTM C 139 and the Standard Detail Drawings. All blocks shall be mortared into place.

921.4.4.3 Eccentric cone or flat-type cover shall be used.

921.4.5 TEE PIPE MANHOLE:

921.4.5.1 Tee pipe manholes will be used for all 4-foot-diameter mainline pipes and larger. Horizontal section of the tee pipe shall be the same class of pipe as the adjacent sections. The vertical sections shall comply with the requirements set forth in ASTM C 478.

921.4.5.2 Top of the vertical portion of tee pipe unit will extend a minimum of 18-inches above the outside diameter of the horizontal pipe. The 4-foot-diameter vertical section of the tee pipe shall be connected at the longitudinal center point of the horizontal pipe section. The minimum length of horizontal pipe section shall be 8 feet.

921.4.5.3 The CONTRACTOR shall submit to the ENGINEER for review and approval preconstruction shop drawings on the fabrication of the tee pipe section as developed by a precast reinforced concrete pipe manufacturer. Field fabrication of this eccentric pipe unit will not be accepted. Shop drawings for the eccentric cone will also be submitted for review and approval.

921.4.5.4 RAM-NEK, Kent Seal, or approved equal sealants shall be used to seal the joints in the vertical portion of this manhole.

921.4.5.5 All lifting holes, except for Type "C" manhole covers, and gaps at joints shall be filled with a non-shrink grout.

921.4.5.6 Standard Detail Drawings show some of the components of the tee-type pipe manhole.

921.4.6 MANHOLE STEPS:

921.4.6.1 Manhole steps shall be ½" diameter, grade 60, reinforcing rod completely encapsulated in copolymer polypropylene or corrosion resistant rubber compound. Steps shall be designed to be cast in place or hammered into holes in manhole walls.

921.4.6.2 Approved manhole steps of only one manufacturer model shall be used on any specific project and shall not be intermixed with other approved steps. Approved steps must bear the manufacturer name and model on the exposed surface of the step and shall be one of the following products or approved equals: M.A. Industries, Inc. – Model

SECTION 921

STORM MANHOLES

PS-2-PFS H.Bowen Co. – Bowco, Model 81213 or 93813 Delta Pipe Products – WEDG-LOK, Model W-11

921.4.6.3 The minimum width of step tread shall be 11-inches. Steps will be spaced uniformly in each manhole. Spacing may be between 12-inches to 16-inches on center. Lower step will be 12-inches above manhole shelf or top of main. The upper step shall be 6-inches below the top portion of the eccentric cone or 6 inches below the bottom of the flat cover. Also the steps shall be aligned vertically with the opening of the cone or cover.

921.4.6.4 Steps shall be embedded in the manhole wall a minimum of 3-inches and protrude from the manhole interior surface a minimum of 4 ¾-inches.

921.4.6.5 Holes for step installation shall be drilled or precast per manufacturer's recommended size, or of sufficient size to allow for step insertion into the wall. Cast-in-place sockets or tapered holes recommended by the step manufacturer may be used with prior approval of ENGINEER. If the hole has been drilled too large, then the step shall be secured in place by using epoxy grout for the full depth of the drilled hole.

921.4.6.6 Acceptable manhole step installations must be capable of withstanding a 400 pound, horizontal, pull out load applied in accordance with ASTM C 497.

921.4.7 ADJUSTMENT BRICKS:

921.4.7.1 Manhole adjustment bricks shall conform to the requirements for manhole bricks, per ASTM C 32 for Grade MS.

921.4.7.2 Mortar shall be used to lay the bricks, as well as coating the interior and exterior surfaces of the laid brick. Thickness of the mortar coating shall be ½-inch.

921.4.8 MANHOLE FRAME AND COVER: The manhole frame and cover for the storm manholes shall conform to the specifications contained in section 161.

921.5 TESTING OF STORM MANHOLES:

921.5.1 Normally storm manholes need not be tested unless specifically required by the project plans or

supplemental technical specifications. However, if in the opinion of the ENGINEER, the workmanship or materials do not appear to be satisfactory, the ENGINEER may require that any storm manhole be tested in a similar manner as that for a sanitary sewer manhole.

921.6 ABANDONMENT OF MANHOLES

921.6.1 Abandonment of manhole, which is part of a storm drain being abandoned, shall entail the following work and materials:

921.6.2 Manhole will not be removed but will be abandoned in place.

921.6.3 All manhole inlet and outlet lines shall be plugged with a 12-inch –thick concrete or concrete mortar plug.

921.6.4 Salvageable material shall be stockpiled on the job site. The CONTRACTOR shall contact Owner to arrange for a representative to inspect the materials for usability. Salvageable materials shall be transported by the CONTRACTOR to the City Yards. CONTRACTOR will receive a receipt for the turned-in materials. Receipts will be submitted to the ENGINEER prior to final acceptance of the Project. Unusable materials will be disposed of by the CONTRACTOR.

921.6.5 Manhole bottom will be pulverized.

921.6.6 The manhole shall be filled with cement treated base (CTB) material to the bottom elevation of the asphalt base course of the pavement or to the ground surface level.

921.6.7 All labor, materials, and equipment necessary to complete this work shall be furnished by the CONTRACTOR.

921.6.8 For historical information the ENGINEER shall have a survey performed which will locate the abandoned manhole, relative to permanent survey markers.

921.7 STORM MANHOLE REHABILITATION IN REPLACEMENT WORK

921.7.1 The work under this item shall be to replace the existing manhole frame and cover and to place a concrete pad around the existing manhole as required

SECTION 921

STORM MANHOLES

per the construction plans. This work will be done only when an existing manhole is encountered in the normal course of the replacement work that has a light-weight, vented, multi-holed manhole cover.

921.7.2 The work and materials shall include the following:

921.7.2.1 Remove any and all existing brick under frame and replace with new Grade MS brick as necessary to bring new frame and cover up to street grade.

921.7.2.2 Remove and replace existing concrete pad, or construct a new pad.

921.7.2.3 Remove existing steps and replace with new steps or if steps are nonexistent, install new steps. Steps will be installed as per Subsection 921.4.6.

921.7.2.4 Remove and replace pavement.

921.7.2.5 Excavation and compaction of backfill as necessary.

921.7.2.6 All materials, labor, and equipment necessary to do the work under this item shall be furnished by the CONTRACTOR.

921.7.2.7 The work and materials under this item shall be done according to the manner set forth in the Standard Detail Drawings and other section of these specifications.

921.7.3 Salvageable material shall be stockpiled on the job site. The CONTRACTOR shall contact Owner to arrange for a representative to inspect the materials for usability. Salvageable materials shall be transported by the CONTRACTOR to the City Yards. CONTRACTOR will receive a receipt for the turned-in materials. Receipts will be submitted to the ENGINEER prior to final acceptance of the Project. Unusable materials will be disposed of by the CONTRACTOR.

921.8 MEASUREMENT AND PAYMENT

921.8.1 NEW MANHOLES:

921.8.1.1 Type "C", "E", "F", or "G" manholes of 4-foot or 6-foot diameters shall be measured per each within the following increments of

depth: 3 to 6 feet, 6 to 10 feet, and 10 to 14 feet. Manholes which are greater in depth than 1 foot shall be measured by the vertical foot. Measurements will be made to the nearest foot and will be from the manhole rim elevation to the manhole invert elevation.

921.8.1.2 Payment for manholes 14 feet deep or less will be made on the unit price per manhole diameter per depth increment as specified in the Bid Proposal. Payment for manhole depths which exceed 14 feet will be made on the unit price per manhole diameter per vertical foot. This payment is in addition to the manhole unit price for the portion above the 14 foot depth.

921.8.1.3 Type "A" or Tee-type manholes shall be measured and paid for by the methods described in 921.8.1.1 and 921.8.1.2 above. Measurement will be from the invert of the main line to the manhole rim. Payment under this item will include the normal manhole costs described below, as well as any additional pipe costs for the precast tee and for the concrete cradle under the tee.

921.8.1.4 Payment for any type diameter or depth of manhole will include excavation, compacted backfilling, shelving, cover or cone, leveling bricks, frame and cover, and concrete pad or collar.

921.8.2 ELEVATION ADJUSTMENTS:

921.8.2.1 When a new manhole is installed, no measurement or payment will be made for rim elevation adjustments to conform to street surface grades.

921.8.2.2 The following measurements and payments for rim elevation adjustments on existing manholes will be made for indicated conditions:

920.8.2.2.1 Unit price per inch of adjustment ring for adjustment to manhole frame by the addition of adjustment ring.

921.8.2.2.2 Unit price per inch of leveling brick adjustment.

921.8.2.2.3 Unit price per manhole diameter per vertical foot of adjustment to cone and/or barrel.

921.8.2.3 As required, the following items will be included in the unit price per appropriate

SECTION 921

STORM MANHOLES

adjustment: pavement removal and replacement, excavation, compacted backfilling, concrete collar or pad, leveling bricks, adjusting rings, and/or frame and cover.

921.8.3 MANHOLE STEPS:

Unless otherwise shown on the Bid Proposal, the cost of manhole steps shall be incidental to the unit prices for construction of manholes of various types and depths.

921.8.4 ABANDONMENT OF MANHOLES:

Measurement and payment for abandonment of a manhole shall be the unit price per manhole for defined work in Subsection 921.6.

921.8.5 MANHOLE REHABILITATION IN REPLACEMENT WORK:

Work under this item shall be measured and paid for by the unit price per manhole for work specified in the Bid Proposal.

921.8.6 TESTING:

There will be no payment for required testing of storm manholes.

SECTION 925

VACUUM SEWER COLLECTOR, INTERCEPTOR AND FORCE MAIN FACILITIES

925.1 GENERAL:

The construction items specified in this section are common to vacuum sewer facilities.

925.2 REFERENCES

925.2.1 American Society for Testing and Materials (ASTM) Standard Specifications, Latest Edition

C 478 Standard Specification for Precast Reinforced Concrete Manhole Sections

D 1557 Standard Test Methods for Laboratory Compaction Characteristics of Soil Using Modified Effort

D 1784 Standard Specification for Rigid Poly (Vinyl Chloride) (PVC) Compounds and Chlorinated Poly (Vinyl Chloride) (CPVC) Compounds

D 2241 Standard Specification for Poly (Vinyl Chloride) (PVC) Pressure-Rated Pipe (SDR Series)

D 2564 Standard Specification for Solvent Cements for Poly (Vinyl Chloride) (PVC) Plastic Piping Systems

D 2665 Standard Specification for Poly (Vinyl Chloride) (PVC) Plastic Drain, Waste, and Vent Pipe and Fittings

D 2672 Standard Specification for Joints for IPS PVC Pipe Using Solvent Cement

D 3139 Standard Specification for Joints for Plastic Pressure Pipes Using Flexible Elastomeric Seals

925.2.1 This Publication, Latest Edition

SECTION 101	PORTLAND CEMENT CONCRETE
SECTION 102	STEEL REINFORCEMENT
SECTION 105	CONCRETE CURING COMPOUND
SECTION 121	PLASTIC PIPE
SECTION 161	GRAY IRON CASTINGS
SECTION 163	DUCTILE IRON CASTINGS
SECTION 170	ELECTRONIC MARKER DEVICES
SECTION 701	TRENCHING, EXCAVATION AND BACKFILL
SECTION 710	BORING, DRILLING AND JACKING
SECTION 801	INSTALLATION OF WATER TRANSMISSION, COLLECTOR, AND DISTRIBUTION LINES
SECTION 901	SANITARY SEWER COLLECTOR AND INTERCEPTOR FACILITIES
SECTION 920	SANITARY AND STORM SEWER MANHOLES

925.3 MATERIALS

925.3.1 PIPE: All buried vacuum collector lines, branch lines, force mains, vacuum service laterals, and gravity service stubs shall be PVC C900 SDR21 (or Class 200) rated PVC pipe, green in color and conforming to ASTM D

2241, ASTM D 1784 Cell Classification 12454-B. Pipe and appurtenances shall be new and unused.

925.3.2 JOINTS:

All joints shall conform to ASTM D 2672, using solvent cement; or ASTM D 3139 using elastomeric seals. This pipe must be certified by the manufacturer that pipe and seal will operate at 22 inches of mercury vacuum with a maximum loss of 1% of initial vacuum per hour for a 4 hour period.

925.3.3 FITTINGS

925.3.3.1 Fittings shall be Schedule 80 solvent weld drain, waste and vent pipe per ASTM D 2665.

925.3.3.2 Wye fittings and 45-degree ells shall be used throughout; except that a long radius 3" 90-degree ell may be used on the 3" suction line entering the vacuum valve and at the wye connection of the vacuum service lateral to the vacuum main. Tee fittings and short radius ells are prohibited exclusively.

925.3.4 SOLVENT CEMENT:

Shall conform to ASTM D 2564: primer and cement shall not be of same color. Cement shall be gray in color.

925.3.5 MANHOLE SECTIONS:

Manhole sections used for buffer tanks, vacuum isolation valve vaults, pig launchers, and air release valves shall be reinforced precast concrete manhole sections, 48" nominal diameter, conforming to the requirements of ASTM C478 and Section 101 Table 101.C.

925.3.6 MANHOLE JOINTS:

Tongue and groove in precast wall; shall conform to Section 920.4.2 PRECAST CONCRETE MANHOLES.

925.3.7 MANHOLE FRAMES AND COVERS:

Frames and covers for sanitary sewer applications such as manholes used for buffer tanks, vacuum isolation valve boxes or vaults, pig launchers, and air release valves shall conform to this Publication, Section 161 Gray Iron Castings, Section 163 Ductile Iron Castings and the Standard Detail Drawings.

925.3.8 CAST-IN-PLACE CONCRETE:

Cast-in-place concrete used for footings, anti-flotation collars, grade-level pads, mass concrete for buffer tanks, and other installations not otherwise addressed shall be air-entrained concrete in accordance with Sections 101, 102, and 105 of this Publication.

925.3.9 VALVES: Valves used for pig launchers and vacuum isolation valves shall be mechanical joint gate valves conforming to Sections 801.3.3 of this Publication. Vacuum isolation valves shall be equipped with five-sided nuts per Standard Detail Drawing 2169. Only valves specified on the Water Approved Product List shall be used.

SECTION 925

VACUUM SEWER COLLECTOR, INTERCEPTOR AND FORCE MAIN FACILITIES

925.3.10 AIR RELEASE VALVES:

Only air release valves specified on the Water Authority Approved Product List shall be used.

925.3.11 VACUUM VALVES AND APPURTENANCES:

Vacuum valves shall be those listed on the Water Authority Approved Product List. Furnish all mechanical appurtenances required for a complete installation per manufacturer specifications. Vacuum valves and appurtenances are to be delivered to the Water Authority's Water Reclamation warehouse, unloaded, and stored as directed by the ENGINEER in complete packages.

925.3.12 VACUUM VALVE PITS

925.3.12.1 Only deep Vacuum valve pits listed on the Water Authority Approved Product List shall be installed.

925.3.12.2 The deep valve pit shall have a sump 54 inches in depth.

925.3.13 STAINLESS STEEL:

Stainless steel for brackets and fasteners shall be Type 316.

925.4 SUBMITTALS

925.4.1 The following shall be submitted for the ENGINEER'S approval prior to incorporation in the work of the corresponding item:

- a) Concrete Mix Design(s)
- b) Material and method of sealing pipe penetrations in buffer tank walls
- c) Pipe certification for vacuum service

925.4.2 The OWNER/ENGINEER will be supplied with a certificate of compliance for each item or type of material required in the system, as to that item meeting the specifications and/or the reference specifications before that item is installed.

925.4.3 The following records shall be maintained by the CONTRACTOR, shall be kept at all times for inspection by the ENGINEER, and shall be submitted to the ENGINEER upon request or as provided in these Specifications.

925.4.3.1 Vacuum tests shall be performed daily or as otherwise stipulated. These tests shall be recorded on charts provided by the OWNER or in hard-board notebooks as stipulated herein depending on the type of test.

925.4.3.2 Record Drawings markups and related survey notebooks shall be kept current by the CONTRACTOR to record work performed and to reflect any and all revisions made from the original construction drawings.

925.5 INSTALLATION

925.5.1 GENERAL

925.5.1.1 Handle pipe and appurtenances in such a manner as to insure delivery to the trench in sound, undamaged condition. Particular care shall be taken to prevent damage to any coating.

925.5.1.2 Prior to installation, store plastic pipe and protect from prolonged periods of sunlight per Section 121.

925.5.1.3 The interior of the pipe, pits, and all appurtenances shall be thoroughly cleaned of foreign material before being lowered into the trench and shall be kept clean during construction operations.

925.5.1.4 Install a plug in the new system at any point of connection to an existing system. The CONTRACTOR shall not flush or otherwise discharge any flow into an existing system unless approved in writing by the ENGINEER and Water Authority.

925.5.1.4.1 The plug shall remain in place until the ENGINEER or Water Authority authorizes its removal in writing. Under all circumstances, the CONTRACTOR shall be required to remove all plugs prior to acceptance of the work.

925.5.1.4.2 The CONTRACTOR shall certify in writing the completion of the plug removal task. The certification shall include the locations of removed plugs and corresponding date of removal. The Water Authority assumes no liability for damages caused by plugs inadvertently left in the line by the Contractor.

925.5.1.5 Perform trenching, backfilling, and compaction in accordance with Section 701.

925.5.2 PIPE INSTALLATION

925.5.2.1 All vacuum sewers shall be laid to line and grade as shown on the construction drawings. All pipe which has been designed to slope downward shall slope uniformly downward, with a tolerance of no more than 0.01 feet per 20 feet of line. Abrupt sags or bellies will not be permitted. The elevation at 100 foot intervals of pipe shall be recorded by the CONTRACTOR in bound field books which shall be submitted to the ENGINEER.

925.5.2.2 All sanitary sewer force mains shall be laid to line and grade as shown on the drawings. Particular care shall be taken to avoid crests in the profile at locations other than those shown on the drawings. Elevations shall be recorded by the CONTRACTOR at 100-foot intervals, and at each change in grade, in bound field books which shall be submitted to the ENGINEER.

925.5.2.3 Handle and install pipe and fittings in accordance with manufacturer's recommendations.

SECTION 925

VACUUM SEWER COLLECTOR, INTERCEPTOR AND FORCE MAIN FACILITIES

925.5.2.4 Prevent entrance of dirt or foreign matter or damage to pipe lining or coating. Plug the pipe any time work is stopped.

925.5.2.5 No defective pieces are permitted. Defective pieces discovered after use will be removed and replaced with a sound piece.

925.5.2.6 Place bedding, embedment and backfill in accordance with Section 701 unless otherwise indicated on the construction plans. The bedding of the trench shall be graded and prepared to provide a firm and uniform bearing throughout the entire length of the pipe. Suitable excavation shall be made to receive the bell of the pipe and the joint shall not bear upon the bottom of the trench. All adjustments to the line and grade shall be made by scraping away or filling in with pipe zone material under the body of the pipe, but not by wedging or blocking. When connections are to be made to any existing pipe, valve pit, or any other improvement, where the actual elevation or position cannot be determined without excavation, excavate and expose the existing improvement before laying the connecting pipe or conduit. Should existing underground improvements be expected to conflict with the line or grade established for the new sewer line, the ENGINEER shall request the CONTRACTOR to excavate as necessary to expose such potentially conflicting underground improvements prior to laying the new pipe. Any adjustment in line or grade which may be necessary to accomplish the intent of the plans shall be made, and the CONTRACTOR will be paid for any additional work resulting from such change in line or grade in the manner provided for in the GENERAL CONDITIONS.

925.5.2.7 Lay pipe upgrade in a continuous operation from structure to structure, with the socket ends of the pipe upgrade unless otherwise permitted by the ENGINEER.

925.5.2.8 Sanitary sewer mains shall not be constructed under walkways, sidewalks, curbs and gutters, drive pads, or similar concrete structures by tunneling underneath them. The CONTRACTOR will remove the section of the concrete structure to the nearest full expansion joint or edge.

925.5.2.9 Place and hand-tamp fill to 95% of maximum dry density per ASTM D 1557, in entire space between the pipe or fitting and the trench walls.

925.5.2.10 Prior to completely backfilling the sewer excavation, install a green metalized detectable warning tape 12" to 18" below finished grade. The tape shall be detectable with a standard metal pipe locator. The tape shall be a minimum of 2 inches wide and inscribed at 10-foot intervals with the words, "CAUTION BURIED SEWER LINE BELOW". The tape shall be constructed of material that is impervious to alkalis, acids, chemical reagents, and solvents found in the soils.

925.5.2.11 Electronic marker devices shall be installed in the locations specified in Section 170 at the manufacturer's recommended bury depth.

925.5.2.12 Provide pipe through casing with support skids as shown on the construction drawings and/or Standard Detail Drawing 2180 and 2380. Alternate support methods may be acceptable upon ENGINEER'S review and approval.

925.5.2.13 Before the work will be accepted, coordinates accurate to within 0.3 feet horizontally and 0.1 feet vertically shall be provided on the Record Drawings for all fitting locations, runs of mainline at a maximum of 100 foot intervals, and all changes in pipe grade. Coordinates shall be determined by a field survey by a Professional Surveyor licensed in the state of New Mexico. Use the NAD 1983 NM STATE PLANE CENTRAL ZONE for x and y coordinates and NAVD 1988 for z coordinate. A report certified by the licensed Professional Surveyor shall be referenced on the Record Drawings.

925.5.2.14 Trace wire shall be installed per Section 901 on all vacuum sewer collectors, interceptors, force mains, and any other portion of the sanitary sewer system considered public infrastructure that will be owned and maintained by the Water Authority.

925.5.3 ISOLATION VALVE

925.5.3.1 Isolation valves and valve box shall be installed per Standard Detail Drawing 2170.

925.5.3.2 Before the work will be accepted, vacuum isolation valve coordinates, accurate to within 0.3 feet, shall be provided on the Record Drawings. Coordinates shall be determined by a field survey by a Professional Surveyor licensed in the state of New Mexico. Use the NAD 1983 NM STATE PLANE CENTRAL ZONE for x and y coordinates and NAVD 1988 for z coordinate. A report certified by the licensed Professional Surveyor shall be referenced on the Record Drawings.

925.5.4 VACUUM VALVE PIT INSTALLATION

925.5.4.1 Install complete vacuum valve pits in accordance with manufacturer instructions and Standard Detail Drawing 2165. Perform pressure testing on each valve pit assembly per the manufacturer instructions.

925.5.4.2 Stub-outs for the gravity service line from the collection sump should be 4" diameter, extended to the property line unless otherwise indicated. Each stub-out should have a stop glued in place 4" to 6" from the end inserted into the tank, to prevent it being pushed too far into the collection sump. A solvent welded 4" cap should be fitted and glued to each stub-out to prevent rocks and groundwater entering the sump prior to connection of the house gravity line. Expandable test plugs or rubber caps are not acceptable as temporary covers for gravity stub-outs.

SECTION 925

VACUUM SEWER COLLECTOR, INTERCEPTOR AND FORCE MAIN FACILITIES

925.5.4.3 Before the work will be accepted, vacuum valve pit coordinates, accurate to within 0.3 feet, shall be provided on the Record Drawings. Coordinates shall be determined by a field survey by a Professional Surveyor licensed in the state of New Mexico. Use the NAD 1983 NM STATE PLANE CENTRAL ZONE for x and y coordinates and NAVD 1988 for z coordinate. A report certified by the licensed Professional Surveyor shall be referenced on the Record Drawings.

925.5.5 SINGLE OR DOUBLE BUFFER TANK INSTALLATION

925.5.5.1 Install single or double buffer tank as shown on the construction drawings and Standard Detail Drawing 2167 (single) or 2168 (double).

925.5.5.2 All pipe penetrations through the buffer tank walls shall be water tight. Submit manufacturer's literature on material and technique for sealing to the ENGINEER.

925.5.5.3 Install suction and sensor pipes as shown on the Standard Detail Drawings. Attach these lines to the buffer tank side walls using Type 304 stainless steel brackets and fasteners. The 3" service lateral is to be stubbed into the buffer tank and capped or otherwise sealed until the vacuum valve is installed.

925.5.5.4 Install breather pipe through buffer tank wall as shown on Standard Detail Drawing 2167 (single) or 2168 (double). This line is to be capped or otherwise sealed to prevent any infiltration of water during construction. It shall be tested in accordance with Breather Test Procedure, Paragraph 925.8.

925.5.5.5 Buffer tanks shall be tested after assembly. The entire buffer tank shall be tested as follows:

925.5.5.5.1 Stub-outs, manhole boots, and pipe plugs shall be permanently secured to prevent movement while the vacuum is drawn.

925.5.5.5.2 Installation and operation of vacuum equipment and indicating devices shall be in accordance with manufacturer's recommendations.

925.5.5.5.3 Using Water Authority-furnished vacuum pump and gage, establish a measured vacuum of 10 inches of mercury in the buffer tank then record the time for the vacuum to drop to nine inches of mercury.

925.5.5.5.4 The maximum allowable leakage rate for a four-foot diameter manhole shall be in accordance with the following:

Min. Elapsed Time For a Pressure
Manhole Depth Change of 1" Hg

10' or less	60 seconds
> 10' but < 15'	75 seconds
≥ 15' but < 25'	90 seconds

925.5.5.5.5 If the buffer tank fails the test, necessary repairs shall be made and the vacuum test and repairs shall be repeated until the tank passes the test. The extent and type of repairs that may be allowed shall be subject to the approval of the ENGINEER. Leaks shall be repaired on the outside of the manhole unless otherwise approved by the ENGINEER.

925.5.5.5.6 If the joint mastic in a buffer tank is pulled out during the vacuum test, the manhole shall be disassembled and the mastic replaced.

925.5.5.5.7 Record test results on a calibrated chart recorder as described in Section 925.6, Field Quality Control.

925.5.5.6 Before the work will be accepted, buffer tank coordinates, accurate to within 0.3 feet, shall be provided on the Record Drawings. Coordinates shall be determined by a field survey by a Professional Surveyor licensed in the state of New Mexico. Use the NAD 1983 NM STATE PLANE CENTRAL ZONE for x and y coordinates and NAVD 1988 for z coordinate. A report certified by the licensed Professional Surveyor shall be referenced on the Record Drawings.

925.5.6 INSTALLATION OF CASING FOR SANITARY SEWER VACUUM MAIN OR FORCE MAIN: Casing for sanitary sewer vacuum main or force main shall be per construction drawings, Standard Detail Drawing 2180, Standard Detail Drawing 2380, and per Section 710 of this publication.

925.5.7 AIR RELEASE VALVE INSTALLATION:

925.5.7.1 Air release valves shall be installed per Standard Detail Drawing 2160.

925.5.7.2 Before the work will be accepted, air release valve coordinates, accurate to within 0.3 feet shall be provided on the Record Drawings. Coordinates shall be determined by a field survey by a Professional Surveyor licensed in the state of New Mexico. Use the NAD 1983 NM STATE PLANE CENTRAL ZONE for x and y coordinates and NAVD 1988 for z coordinate. A report certified by the licensed Professional Surveyor shall be referenced on the Record Drawings.

925.6 FIELD QUALITY CONTROL

925.6.1 Provide daily testing of all sewer mains and lateral connections that are laid. Plug all open connections with rubber stoppers or temporary caps, fitted to the pipe by "no-hub" couplings. Using Water Authority-furnished vacuum pump and chart recorder, apply a vacuum to 22 inches of mercury to the pipes with pump running continuously for 15 minutes to allow vacuum to stabilize before proceeding with test. There shall be no loss in excess of 1% of initial vacuum per hour for a two hour test

SECTION 925

VACUUM SEWER COLLECTOR, INTERCEPTOR AND FORCE MAIN FACILITIES

period. As pipe is laid the new section shall be tested in addition to the previously laid pipe on that main.

925.6.2 Leave uncovered the sewer main pipe joints until after the daily vacuum test is complete so that any leaks can be easily located and repaired. Exposed joints shall be adequately restrained.

925.6.3 Two-hour Vacuum Line Test Modification Provision: If the CONTRACTOR succeeds in meeting the daily 2-hour test for seven consecutive working days or two thousand feet of pipe, the ENGINEER may amend the procedure to allow the trench to be covered as work progresses rather than the trench being kept open all day as is the norm with the daily 2-hour test. Should a line fail the vacuum test while utilizing this test modification, the CONTRACTOR shall take whatever action is necessary at his cost to pass the test including the excavation of the trench, leak detection and line repair, and additional cleanup as required by the ENGINEER. After the failure, the CONTRACTOR must re-qualify as specified above. Note this test modification is optional, and as such, the CONTRACTOR assumes all liability in its use. Allowance of this modification by the ENGINEER is not considered acceptance of the sewer line or ability to withstand test vacuum pressures.

925.6.4 Installation and operation of vacuum equipment and indicating devices shall be in accordance with manufacturer's recommendations.

925.6.5 Required Final Acceptance Testing on complete system: Provide 48-hour notice (minimum) to ENGINEER prior to test. Ensure all isolation valves are open prior to beginning of test. Subject the entire sewerage system to a vacuum of 22 inches of mercury, and allow the system to stabilize for 15 minutes before proceeding with test. There shall be no loss greater than 1% of initial vacuum per hour over a four hour test period.

925.6.6 All daily testing and Final Acceptance Test shall be recorded on vacuum charts to be provided by the ENGINEER. These charts will not be considered valid unless witnessed by ENGINEER on test equipment at beginning and end of vacuum test period.

925.6.7 The ENGINEER will sign and date charts to verify witness of tests. This signature does not indicate acceptance of the system.

925.7 LINE FLUSHING

925.7.1 After acceptance testing, flush lines to remove debris and foreign materials that accumulated in the lines during construction.

925.7.1.1 Suggested procedure (This procedure requires the use of vacuum valves. Coordination of installation by the Water Authority is the responsibility of the CONTRACTOR):

925.7.1.1.1 Place system under vacuum to 22 inches mercury.

925.7.1.1.2 Add water to valve pits at extreme ends of system and cause vacuum valves to operate and draw water into piping system.

925.7.1.1.3 Utilize system vacuum to transport the water and debris to collection point. Continue procedure until water entering at collection point is free of contamination or debris. If vacuum station collection tank is used as collection point, monitor volume of liquid in tank and pump out as necessary by means other than system sewage pumps. After completion of flushing, clean collection tank of all collected debris.

925.7.1.1.4 Restore vacuum collection tank and collection system to permanent configuration and make ready to place into operation.

925.7.1.2 Alternate flushing procedures are subject to ENGINEER'S review and approval.

925.8 BREATHER TESTING

925.8.1 After entire breather assembly is complete from the above ground flexible extension to the interior of the valve vault or buffer chamber, it shall be pressure tested as follows:

925.8.1.1 Fabricate a test pipe using ¾-inch PVC materials or approved equal; one end to be ¾-inch male pipe thread, the opposite end to terminate with a 1/8-inch tubing connection.

925.8.1.2 Remove breather dome and install the test pipe in its place. Pressurize the breather assembly to a minimum 40-inch water gage as measured with a magnehelic gauge. The assembly shall remain at a constant pressure with no detectable leaks for a minimum of one minute in the presence of the on-site field inspector. A dated record of all testing of breather domes shall be maintained in a bound notebook, which shall be turned over to the ENGINEER upon completion of all work.

925.9 MEASUREMENT AND PAYMENT

925.9.1 SANITARY SEWER FORCE MAIN WITH BEDDING

925.9.1.1 Measurement shall be per linear foot measured horizontally along the centerline of pipeline and fittings from the collection/lift station interface to the point of discharge as shown on the construction drawings. No deduction from the total will be made for intermittent installations such as isolation valves, pig launchers, and associated manholes.

925.9.1.2 Payment will be in accordance with the unit price per linear foot per size and material as defined in the Bid Proposal, and shall include: unclassified excavation in

SECTION 925

VACUUM SEWER COLLECTOR, INTERCEPTOR AND FORCE MAIN FACILITIES

open trench, backfilling, and compaction for all trench zones; hand digging; removing and replacing surface obstructions; discovery and protection of subsurface obstructions; shoring and bracing; hauling excavated material; restoration of disturbed areas not included in other pay items; all fittings, concrete thrust blocking or restrained joints; installation of electronic marking devices and green metalized warning tape; preparation of pipe subgrade; furnishing and placing granular bedding; trench dewatering; temporary connections; jointing and coupling materials; furnishing and installing pipe in open trench; flushing and cleaning the pipe; air and hydrostatic pressure testing; and all other labor, material, and equipment incidental thereto.

925.9.2 SANITARY SEWER FORCE MAIN PIG LAUNCHER

925.9.2.1 Measurement of installed pig launcher shall be per each unit installed as shown on the construction drawings.

925.9.2.2 Payment for the pig launchers will be in accordance with the unit price per each as defined in the Bid Proposal, and shall include: furnishing and installing all fittings, flanges, restraining glands, and harnesses; drilling and preparing precast manhole section for slotted opening including gaskets, sealants, and grout; furnishing and installing resilient seat gate valves; preparing and installing cast-in-place concrete footer and pad on finished ground including trenching, backfilling, and compaction, furnishing and installing reinforcing steel; furnishing and installing precast manhole sections including trenching, backfilling, and compaction, gaskets, electronic marker device, frame and cover; furnishing and installing gravel bed for floor of manhole; and all other labor, material, and equipment incidental thereto.

925.9.3 BORE AND JACK, CASING FOR SANITARY SEWER VACUUM MAIN OR FORCE MAIN

925.9.3.1 Measurement shall be per linear foot, measured horizontally along the centerline of the encasement pipe actually installed for the work accomplished as shown on the Standard Detail Drawings and on the construction drawings.

925.9.3.2 Payment will be in accordance with the unit price per linear foot as defined in the Bid Proposal, and shall include: trenching, unclassified excavation, backfilling, and compaction; furnishing and installing bored steel casing, casing insulators, and casing end seals; repair and replacement of existing roadway, bridge abutments, utilities, or any other structures damaged during boring and jacking operations; removal and disposal of waste material; providing grout for backfilling; inspections or permits; and all other labor, material, and equipment incidental thereto; except that the carrier pipe will be paid for under the appropriate bid item for vacuum main or force main.

925.9.4 SANITARY SEWER AIR RELEASE VALVE

925.9.4.1 Measurement shall be per each air release valve installed as shown on the Standard Detail Drawings and the construction drawings.

925.9.4.2 Payment will be in accordance with the unit price per each as defined in the Bid Proposal, and shall include: furnishing and installing air release valve with all necessary fittings and appurtenances; drilling and preparing precast manhole section for slotted opening including gaskets, sealants, and grout; preparing and installing cast-in-place concrete footer and pad on finished ground including trenching, backfilling, and compaction, furnishing and installing reinforcing steel; furnishing and installing precast manhole sections including trenching, backfilling, and compaction, gaskets, electronic marker device, frame, and cover; furnishing and installing gravel bed for floor of manhole; and all other labor, material, and equipment incidental thereto.

925.9.5 VACUUM SEWER ISOLATION VALVE AND VALVE BOX

925.9.5.1 Measurement shall be per each vacuum sewer isolation valve and valve box installed as shown on the construction drawings and the Standard Detail Drawing.

925.9.5.2 Payment will be in accordance with the unit price per each as defined in the Bid Proposal, and shall include: furnishing and installing resilient seat gate valve with all necessary fittings and appurtenances; furnishing the Water Authority with one 6-foot long T-handle extension bar for every five valves installed; furnishing, drilling, and preparing precast manhole section for slotted opening including gaskets, sealants, and grout; preparing and installing cast-in-place concrete footer and pad on finished ground including trenching, backfilling, and compaction; furnishing and installing reinforcing steel; furnishing and installing precast manhole sections including trenching, backfilling, and compaction, gaskets, electronic marker device, frame, and cover; furnishing and installing gravel bed for floor of manhole; and all other labor, material, and equipment incidental thereto.

925.9.6 VACUUM SEWER BUFFER TANK

925.9.6.1 Measurement shall be per each installed buffer tank (single or double per the respective bid item) as shown on the construction drawings and the Standard Detail Drawings.

925.9.6.2 Payment will be in accordance with the unit price per each as defined in the Bid Proposal, and shall include: furnishing and installing all necessary equipment, including pipe and breather connections, breather vent piping and flexible breather pipe assembly; preparing and installing cast-in-place concrete footer and pad on finished ground including trenching, backfilling, and compaction, furnishing and installing reinforcing steel; furnishing and installing precast manhole sections including trenching,

SECTION 925

VACUUM SEWER COLLECTOR, INTERCEPTOR AND FORCE MAIN FACILITIES

backfilling, and compaction, gaskets, frame, and cover; furnishing and installing all fittings, pipe, and all appurtenances; connection of the new or existing sanitary sewer gravity lines including drilling precast manhole sections, gaskets, sealants, and grout; furnishing and installing concrete grout for shelf; air and vacuum testing as required; and all other labor, material, and equipment incidental thereto.

925.9.7 VACUUM VALVE PIT

925.9.7.1 Measurement shall be per each deep vacuum pit installed as shown on the construction drawings and the Standard Detail Drawings.

925.9.7.2 Payment will be in accordance with the unit price per each as defined in the Bid Proposal, and shall include: furnishing and installing all necessary equipment including unclassified excavation in open trench, backfilling, and compaction for all trench zones; hand digging; removing and replacing surface obstructions including fencing, landscaping, and all other obstructions; discovery and protection of subsurface obstructions; shoring and bracing; hauling excavated material, restoration of disturbed areas not included in other pay items; all fittings and concrete anti-flotation collar; installation of flexible breather pipe assembly and all appurtenances; stub-outs for connection of gravity and vacuum lines; air, vacuum, and all other testing as required; and all other labor, material, and equipment incidental thereto.

925.9.8 VACUUM COLLECTION LINES AND VACUUM SERVICE LATERALS

925.9.8.1 Measurement of vacuum collection lines and vacuum service laterals shall be per linear foot measured horizontally along the centerline of pipeline as shown on the drawings.

925.9.8.2 Payment will be in accordance with the unit price per linear foot per size and material as defined in the Bid Proposal, and shall include: unclassified excavation in open trench, backfilling, and compaction for all trench zones; hand digging; removing and replacing surface obstructions; discovery and protection of subsurface obstructions; shoring and bracing; hauling excavated material, restoration of disturbed areas not included in other pay items; all fittings, concrete thrust blocking or restrained joints; preparation of pipe subgrade; furnishing and placing granular bedding; trench dewatering; temporary connections; jointing and coupling materials; furnishing and installing pipe in open trench; flushing and cleaning the pipe; field quality control testing including daily vacuum testing of lines using Water Authority furnished trailer mounted vacuum pump, breather testing, and all other testing required; making all required submittals; and all other labor, material, and equipment incidental thereto.

925.9.9 VACUUM VALVES AND APPURTENANCES:

Measured and paid for per each as a separate pay item as included in the associated Vacuum Pit or Buffer Tank as specified and provided in the Bid Proposal.

925.9.10 TRACE WIRE: All work associated with the installation of the trace wire and system shall be considered incidental to the installation cost of the pipeline being traced.

