

LIGHTING LEGEND

Table with 2 columns: SYMBOL, DESCRIPTION. Lists lighting fixtures like P1, 2P1, W1, W2, PT, CA and their specifications.

SITE LEGEND

Table with 2 columns: SYMBOL, DESCRIPTION. Lists site features like property line, accessible parking, fire hydrant, parking spaces.

DEVELOPMENT DATA

LEGAL DESCRIPTION: TRACT 1, THE FOOTHILLS

LOT AREA: NET: 699,323 SF 16.054 acres

ZONING: CURRENT: R-MH LAND USE: MULTI-FAMILY RESIDENTIAL

CONSTRUCTION TYPE: PROVIDED: VA & VB

AMENITIES: POOL, SPA, FITNESS, RECREATION CLUB ROOM, RAMADAS, CABANAS, BBQ

SETBACKS: PROVIDED: FRONT (SOUTH): 5'-0" SIDE (EAST): 6'-4" SIDE (WEST): 82'-9" REAR (NORTH): 15'-0"

\* VARIANCE OF 10 FEET TO THE 15-FOOT MINIMUM FRONT SETBACK APPROVED BY EPC UNDER APPLICATION NUMBER: VA-2020-00244

BLDG HEIGHT: ALLOWED: 45 FEET

UNIT MIX:

Table with 2 columns: UNIT GARDEN, UNIT TH. Lists unit types like 1 Bedroom, 2 Bedroom, 3 Bedroom and their counts.

- ALL GROUND FLOOR UNITS IN BLDGS TYPE 1 AND TYPE 2 SHALL BE OF AT LEAST ANSI TYPE 'B' ACCESSIBILITY STANDARDS.

DENSITY: PROPOSED: 17.50 D.U. / ACRE

KEYNOTES

- 1001 8.5x18' PARKING SPACE WITH 2' OVERHANG, TYPICAL. SEE DETAIL 1/A1.20.
- 1002 10x20' PARALLEL PARKING SPACE.
- 1003 11x18' ACCESSIBLE PARKING SPACE WITH 2' OVERHANG, SEE DETAIL 6/A1.20.

PROJECT NUMBER: PR-2020-004086 Application Number: SI-2020-00690

This Plan is consistent with the specific Site Development Plan approved by the Environmental Planning Commission (EPC), dated 9/10/2020, and the Findings and Conditions in the Official Notification of Decision are satisfied.

Is an Infrastructure List required? ( ) Yes ( ) No. If yes, then a set of approved DRC plans with a work order is required for any construction within Public Right-of-Way or for construction of public improvements.

DRB SITE DEVELOPMENT PLAN SIGNOFF APPROVAL:

Table for signoff approval with columns: Department, Date. Includes Traffic Engineering, ABCWUA, Parks and Recreation, City Engineer, Solid Waste Management, Code Enforcement, DRB Chairperson.

ALLASO HIGH DESERT SWC TENNYSON STREET AND SAN ANTONIO DR. ALBUQUERQUE, NEW MEXICO

Office of Rich Barber Architecture, INC ORB WorldHQ@ORBArch.com

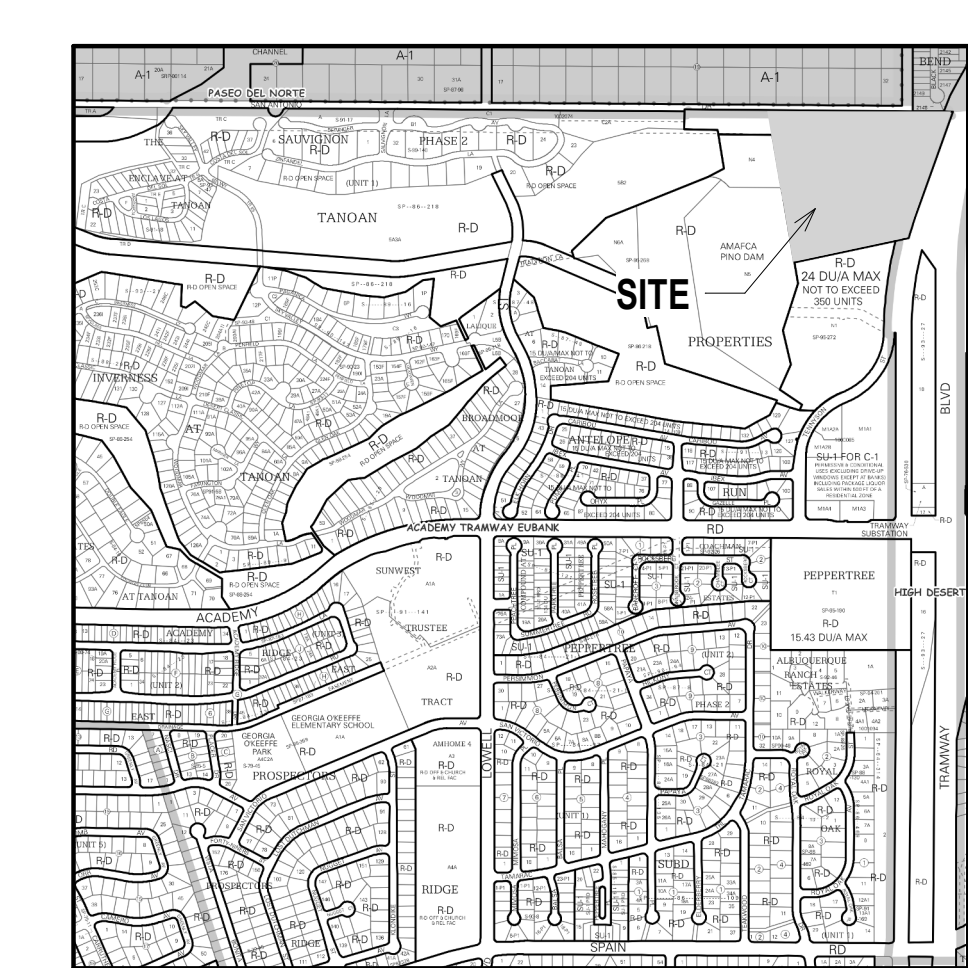

PRELIMINARY SITE PLAN

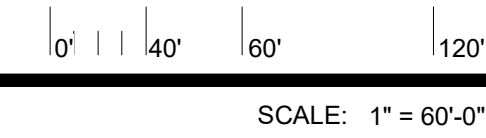

VICINITY MAP NOT TO SCALE

DRB SUBMITTAL DATE: OCTOBER 5, 2020 DRB #: 19-209

A1.10 PRELIMINARY SITE PLAN

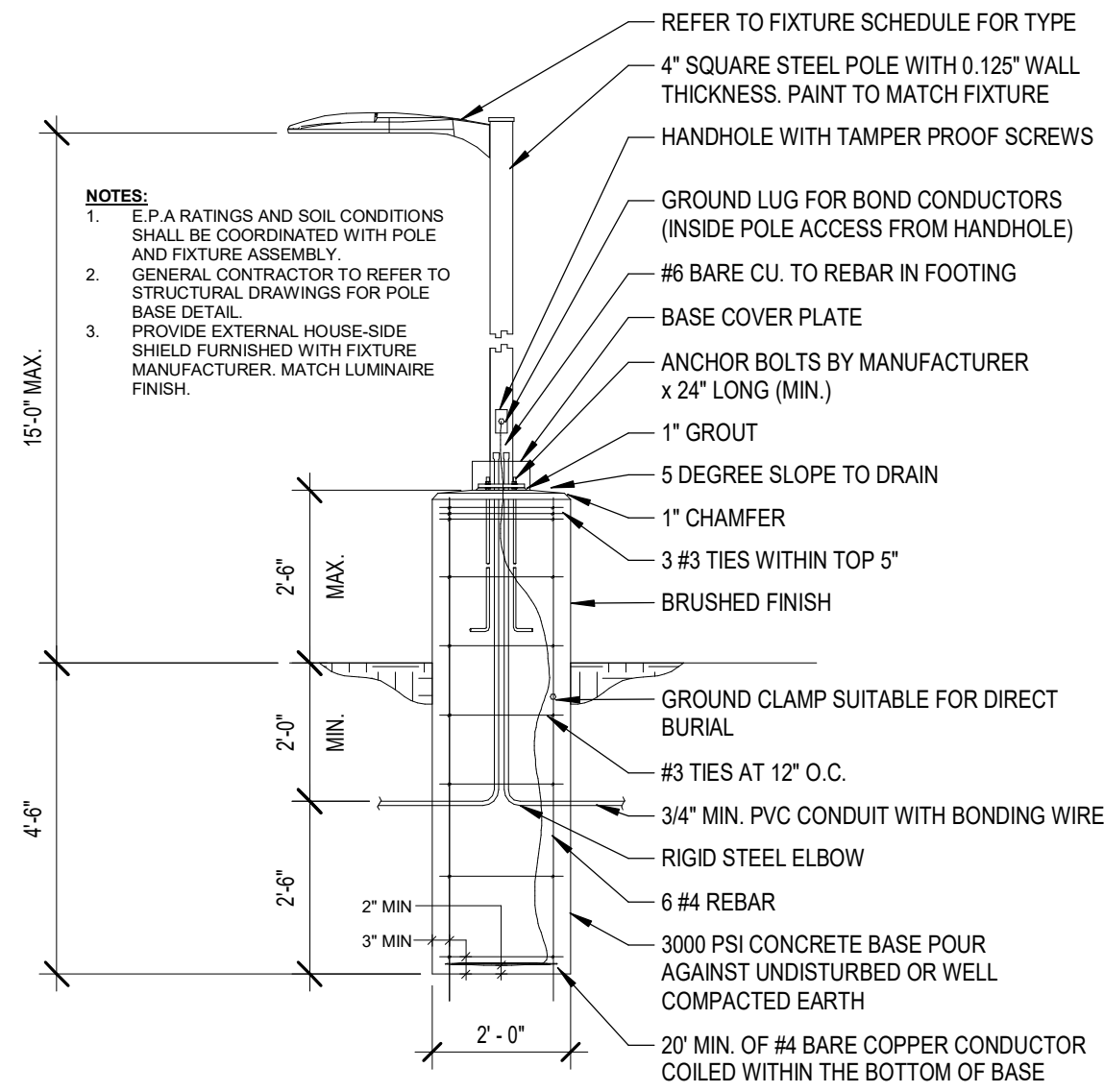

13 POLE MOUNTING DETAIL

SCALE: 3/8" = 1'-0"

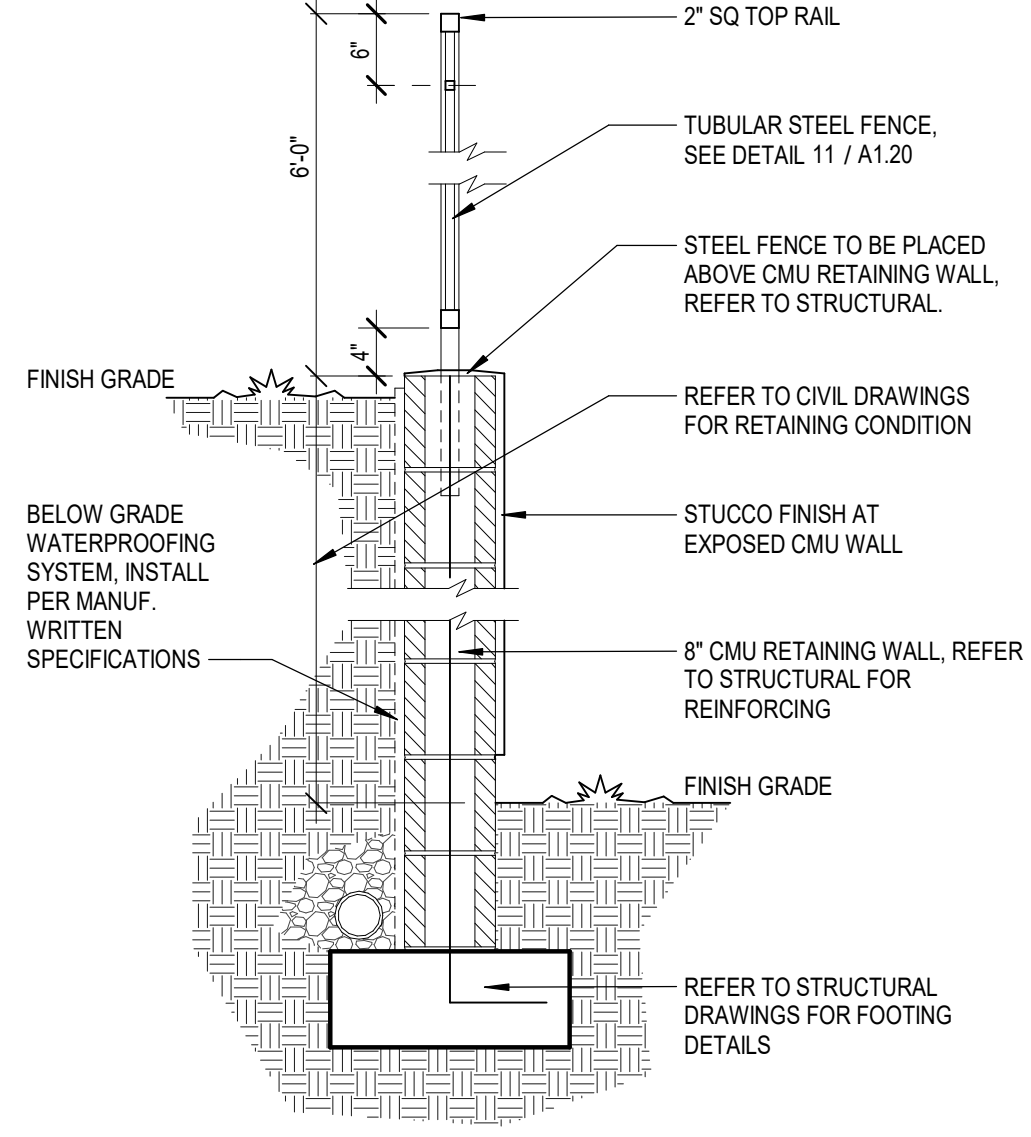

10 PERIMETER RETAINING WALL

SCALE: 3/4" = 1'-0"

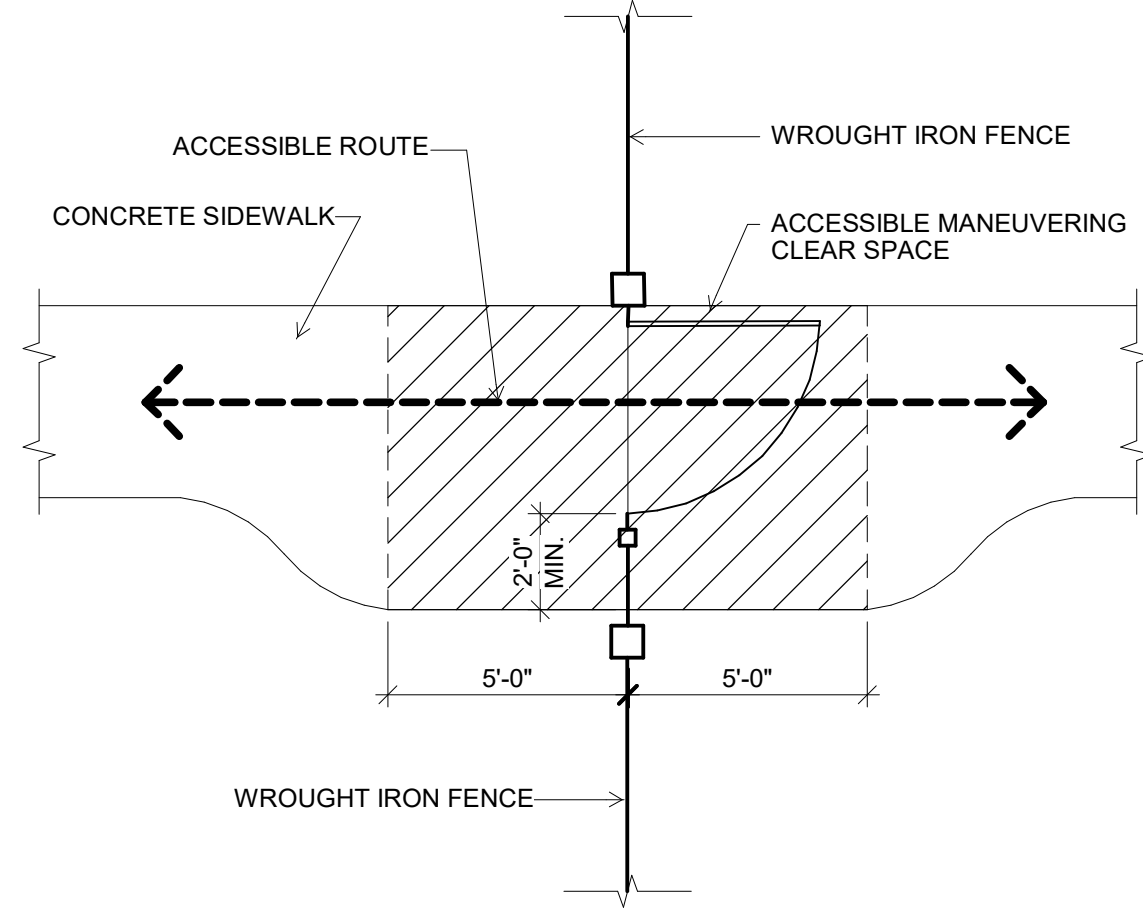

7 ACCESSIBLE MANEUVERING SPACE AT GATES

SCALE: 1/4" = 1'-0"

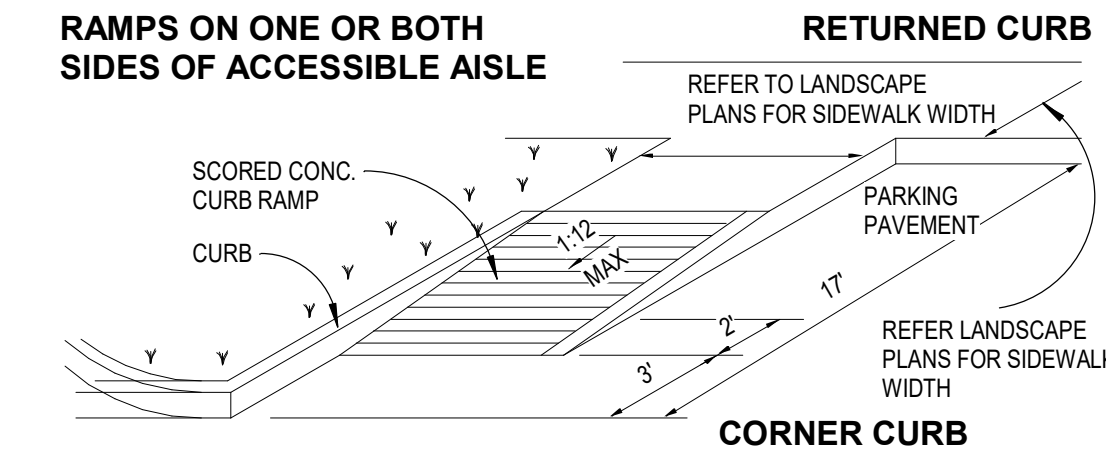
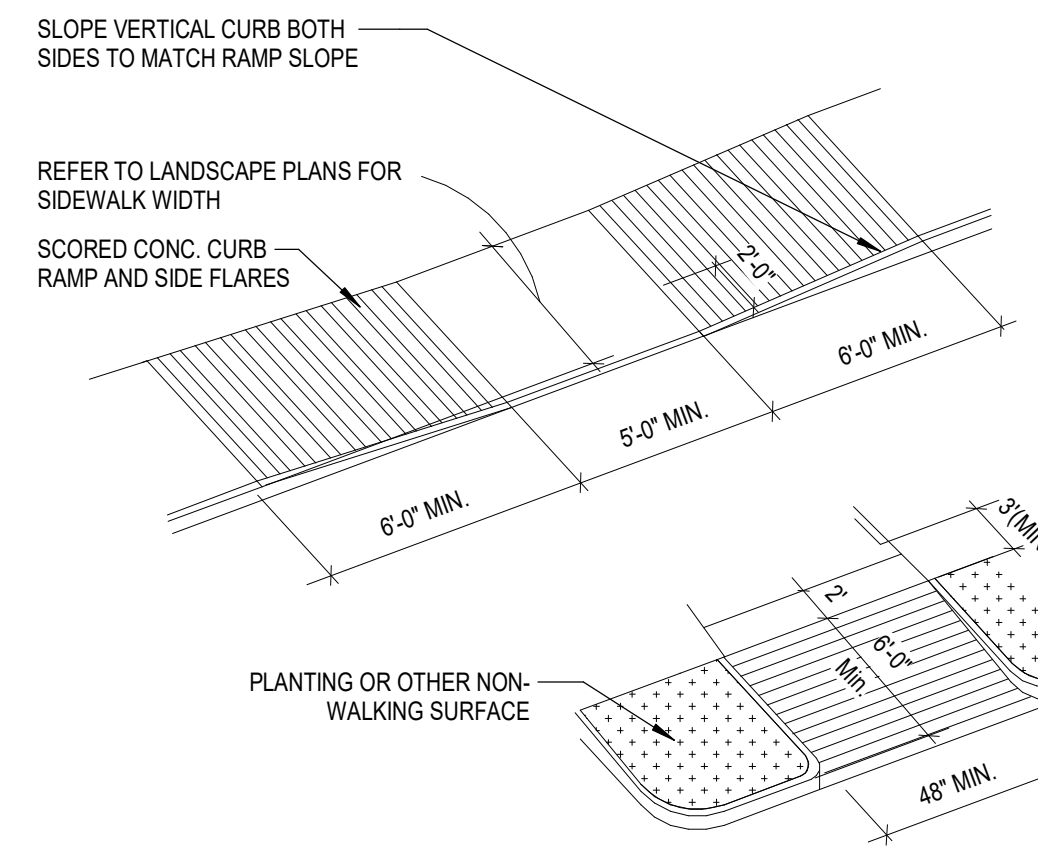
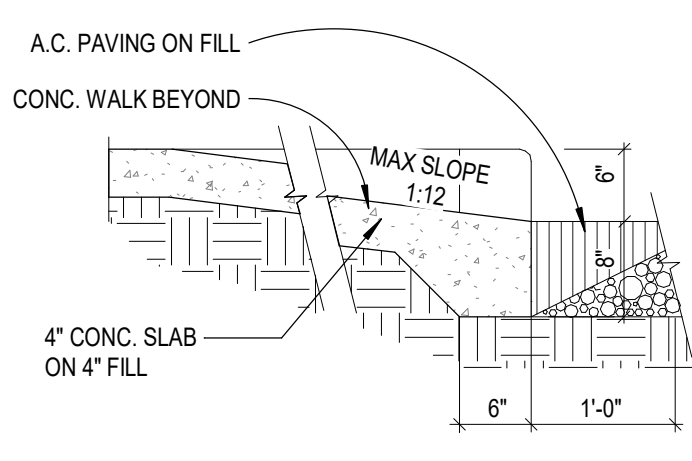
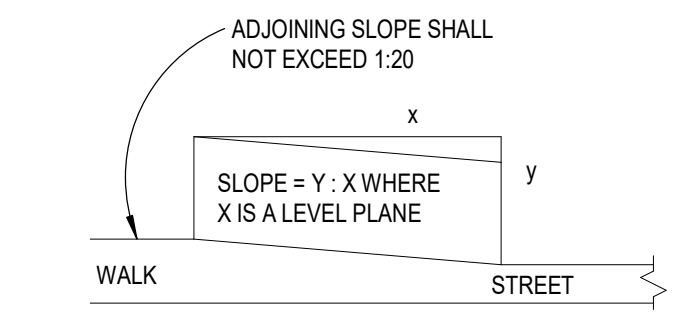

5 TYPICAL ACCESSIBLE RAMP

SCALE: 1/4" = 1'-0"

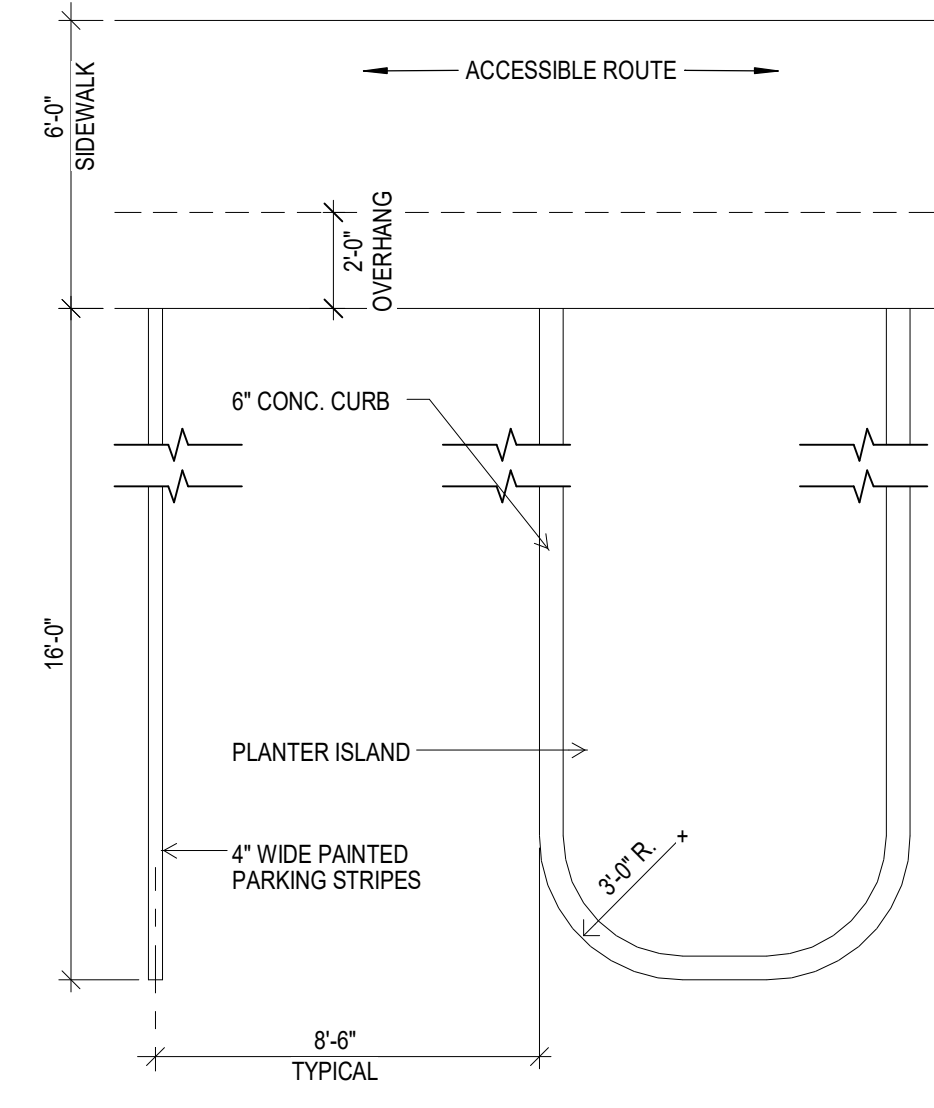

1 TYPICAL PARKING STALL W/ ISLAND

SCALE: 1/4" = 1'-0"

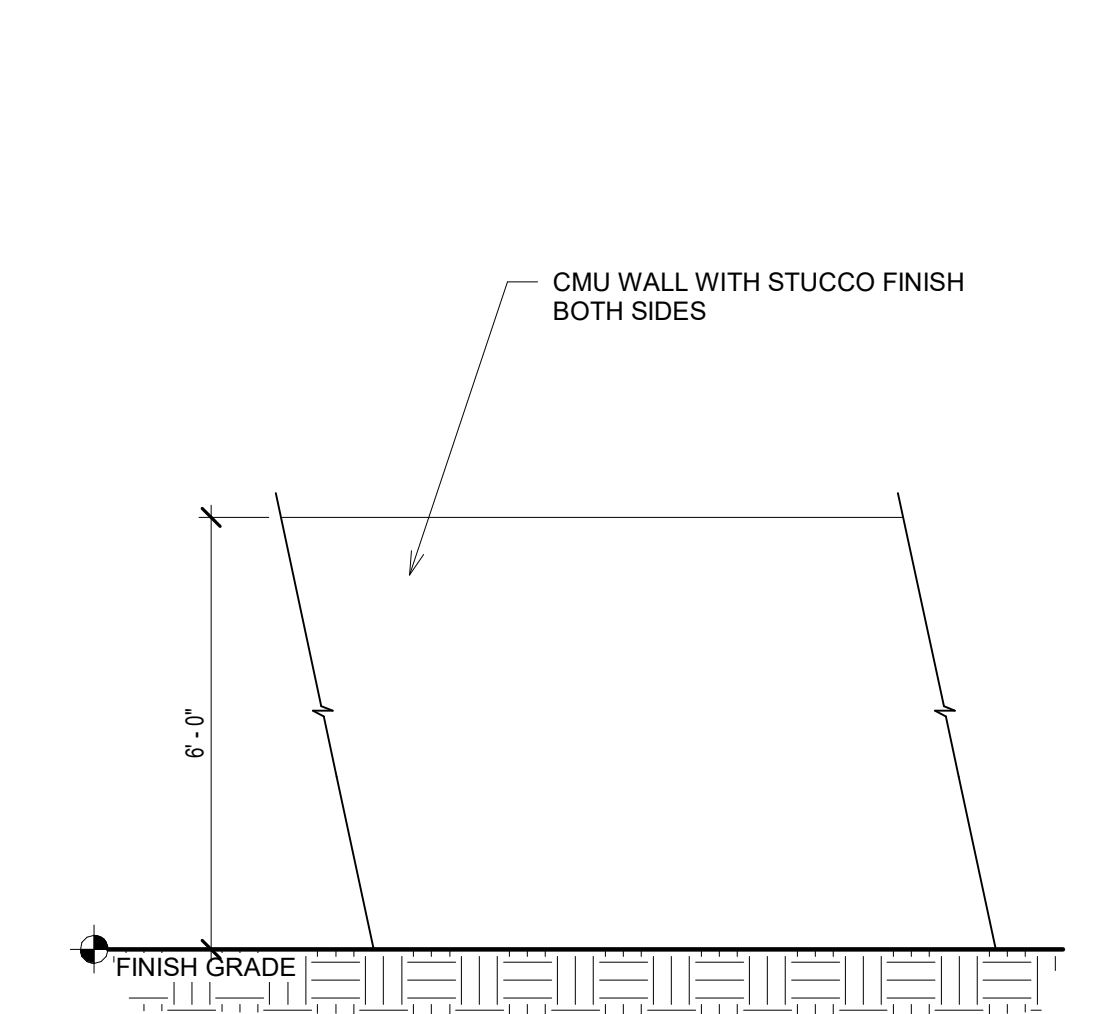

14 PERIMETER SOLID WALL

SCALE: 3/8" = 1'-0"

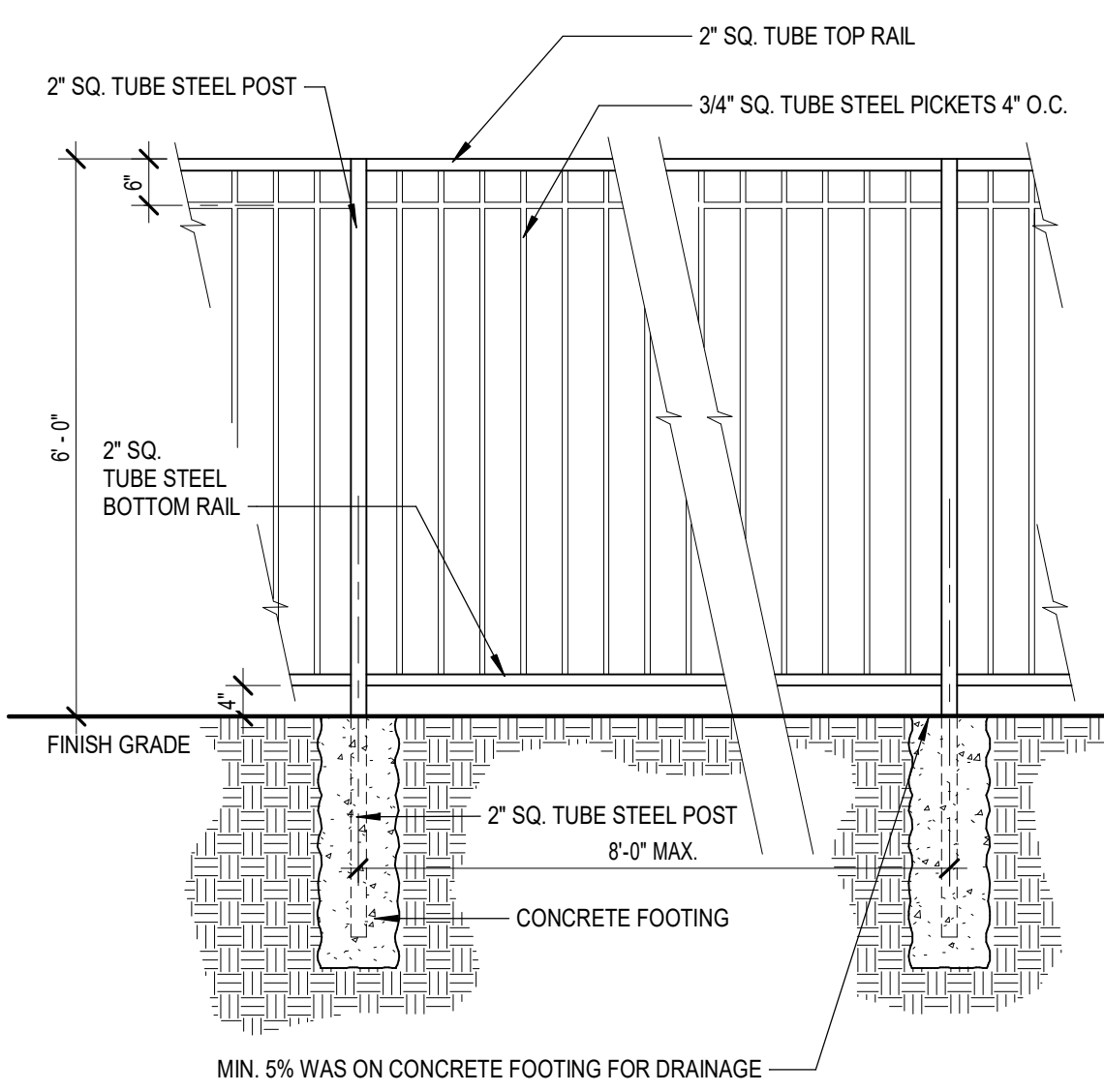

11 TUBULAR STEEL FENCE

SCALE: 1/2" = 1'-0"

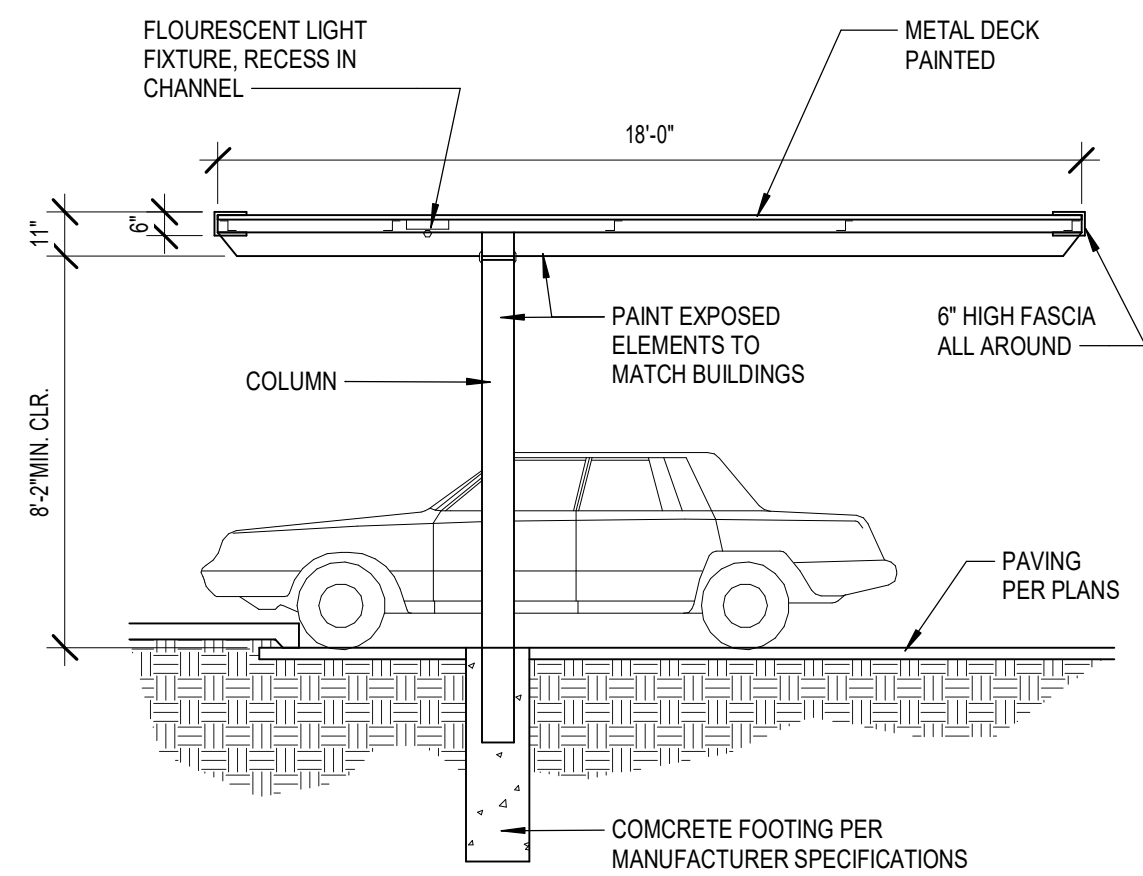

8 CARPORT DETAIL

SCALE: 1/4" = 1'-0"

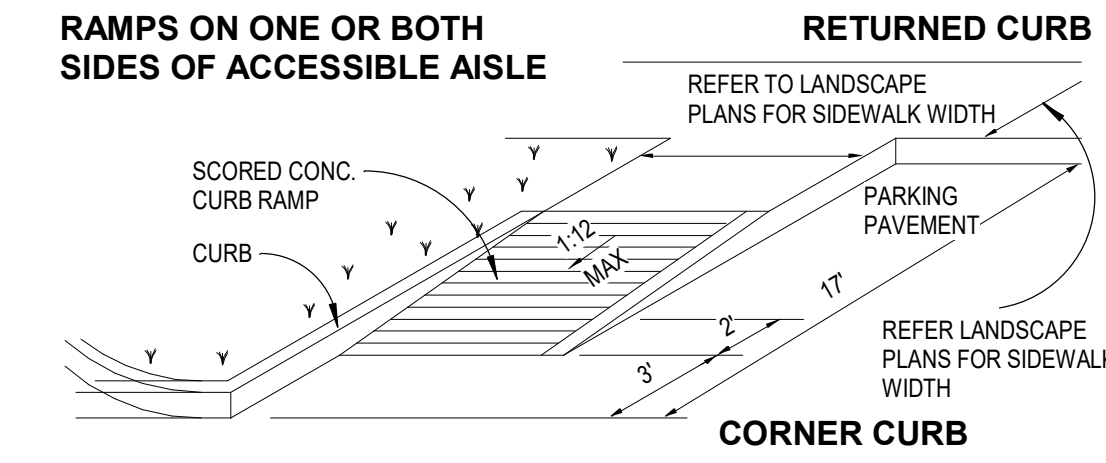
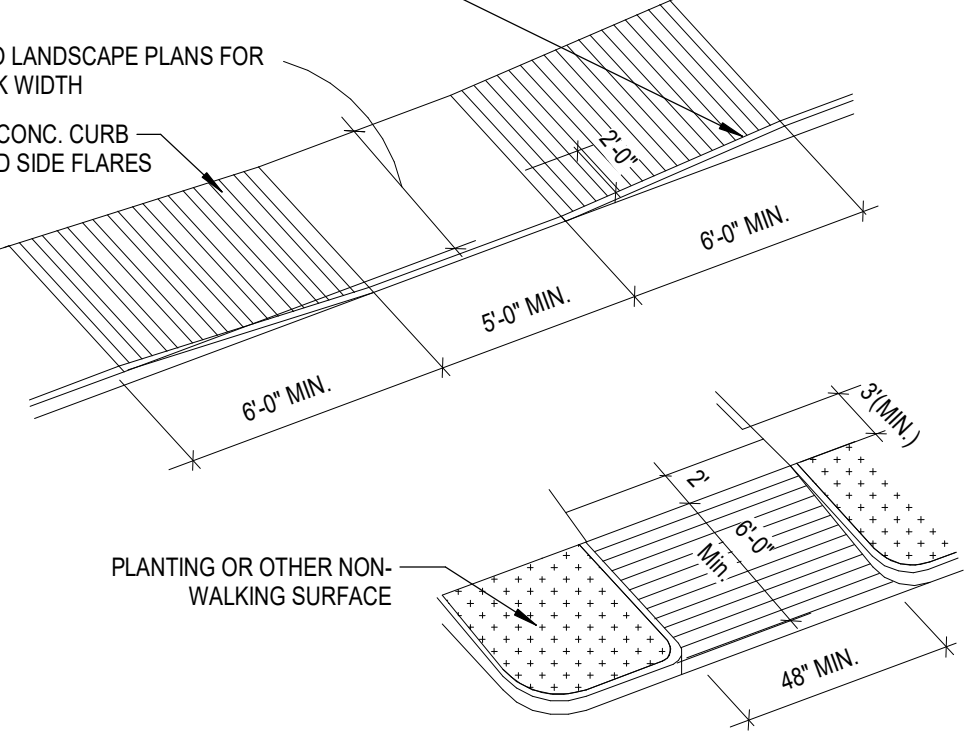

5 TYPICAL ACCESSIBLE RAMP

SCALE: 1/4" = 1'-0"

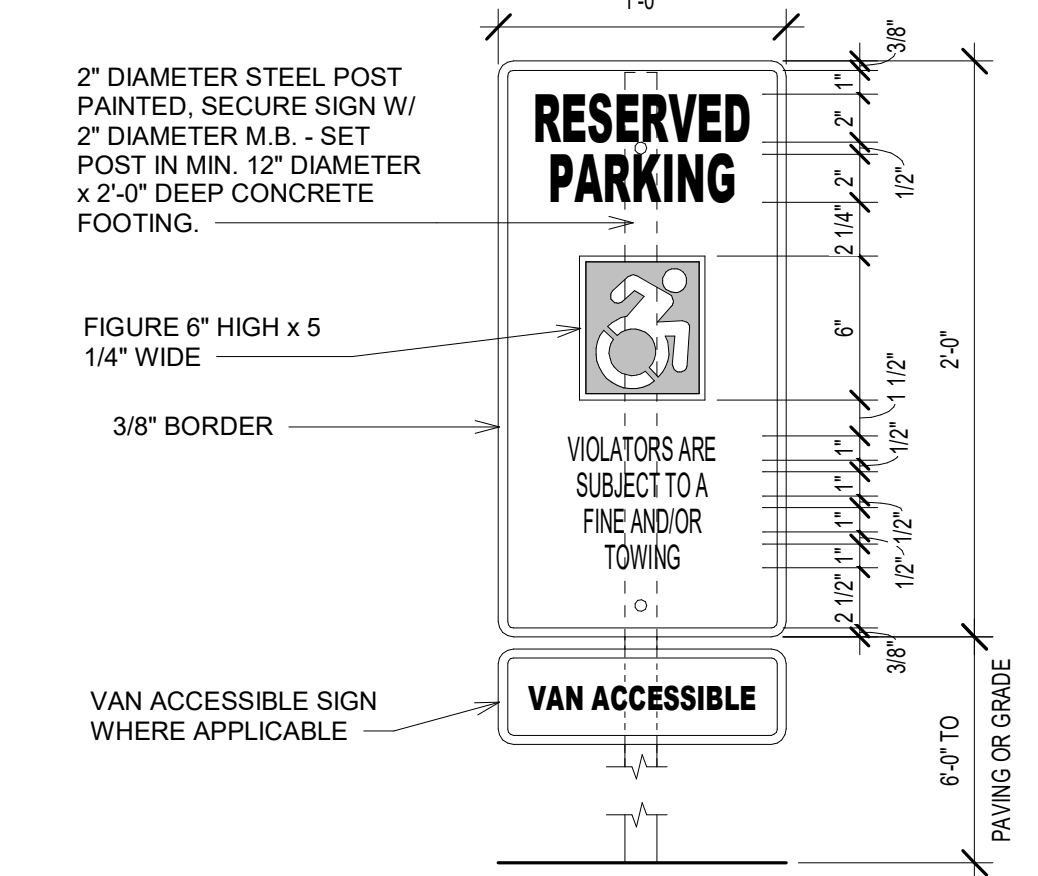

2 ACCESSIBLE PARKING SIGN

SCALE: 1 1/2" = 1'-0"

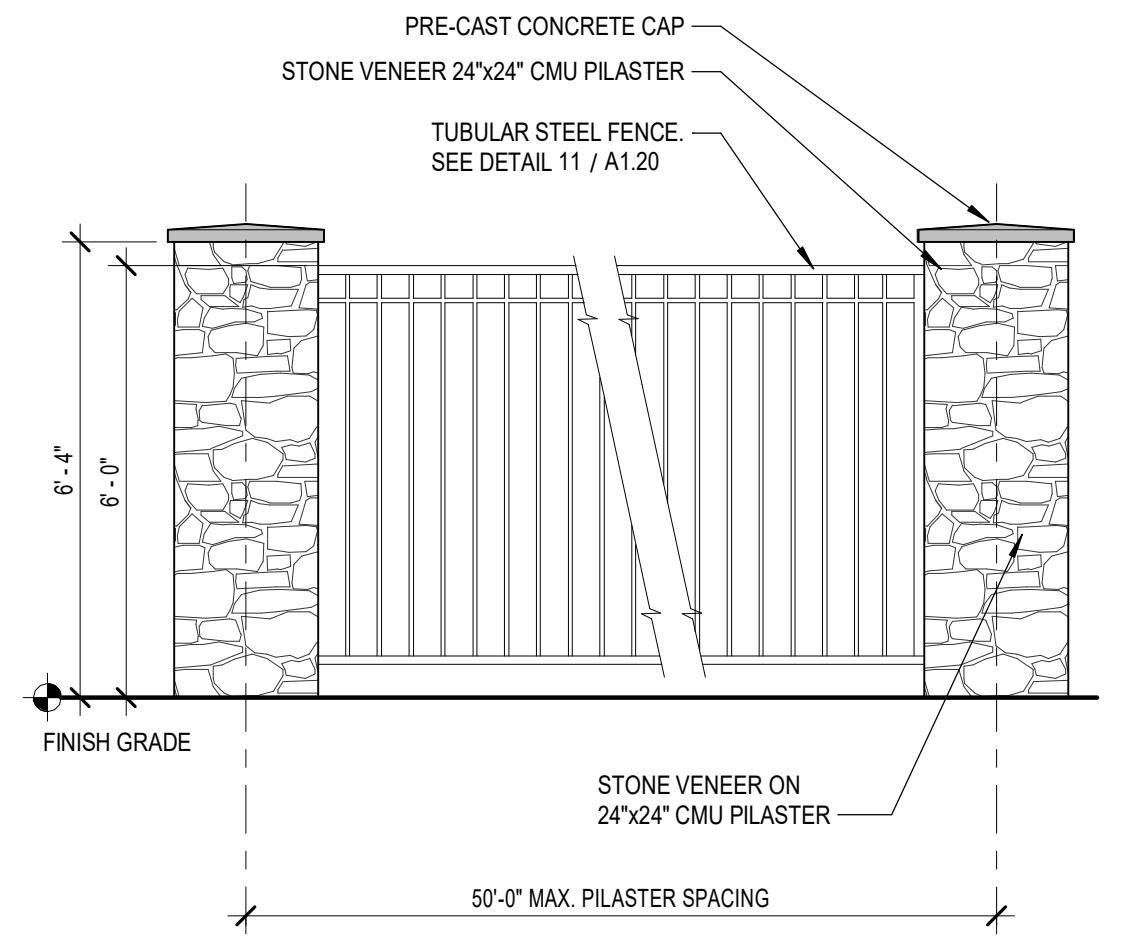

12 PILASTER AT PERIMETER TUBULAR STEEL FENCE

SCALE: 3/8" = 1'-0"

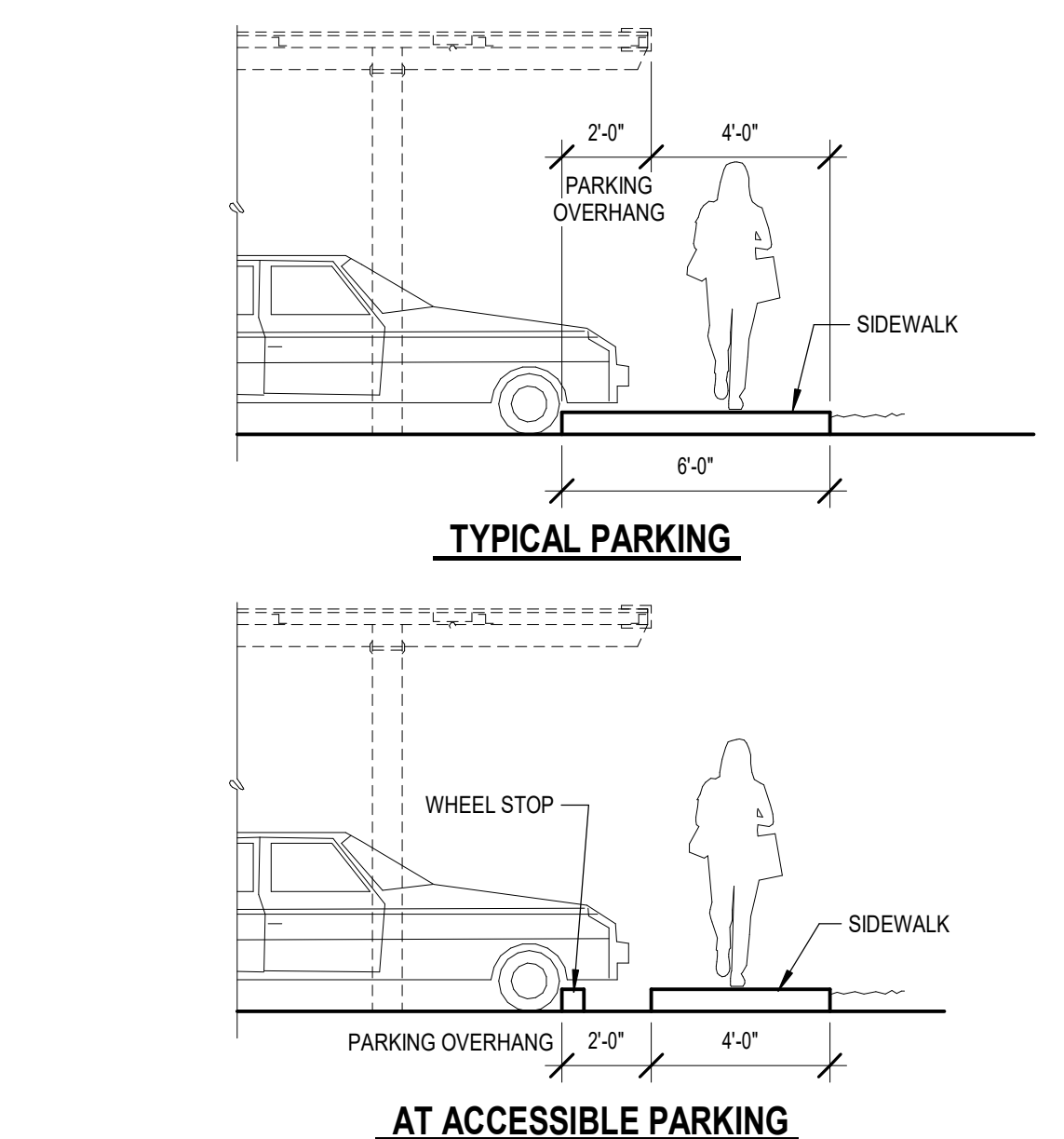

9 SIDEWALK AT PARKING

SCALE: 1/4" = 1'-0"

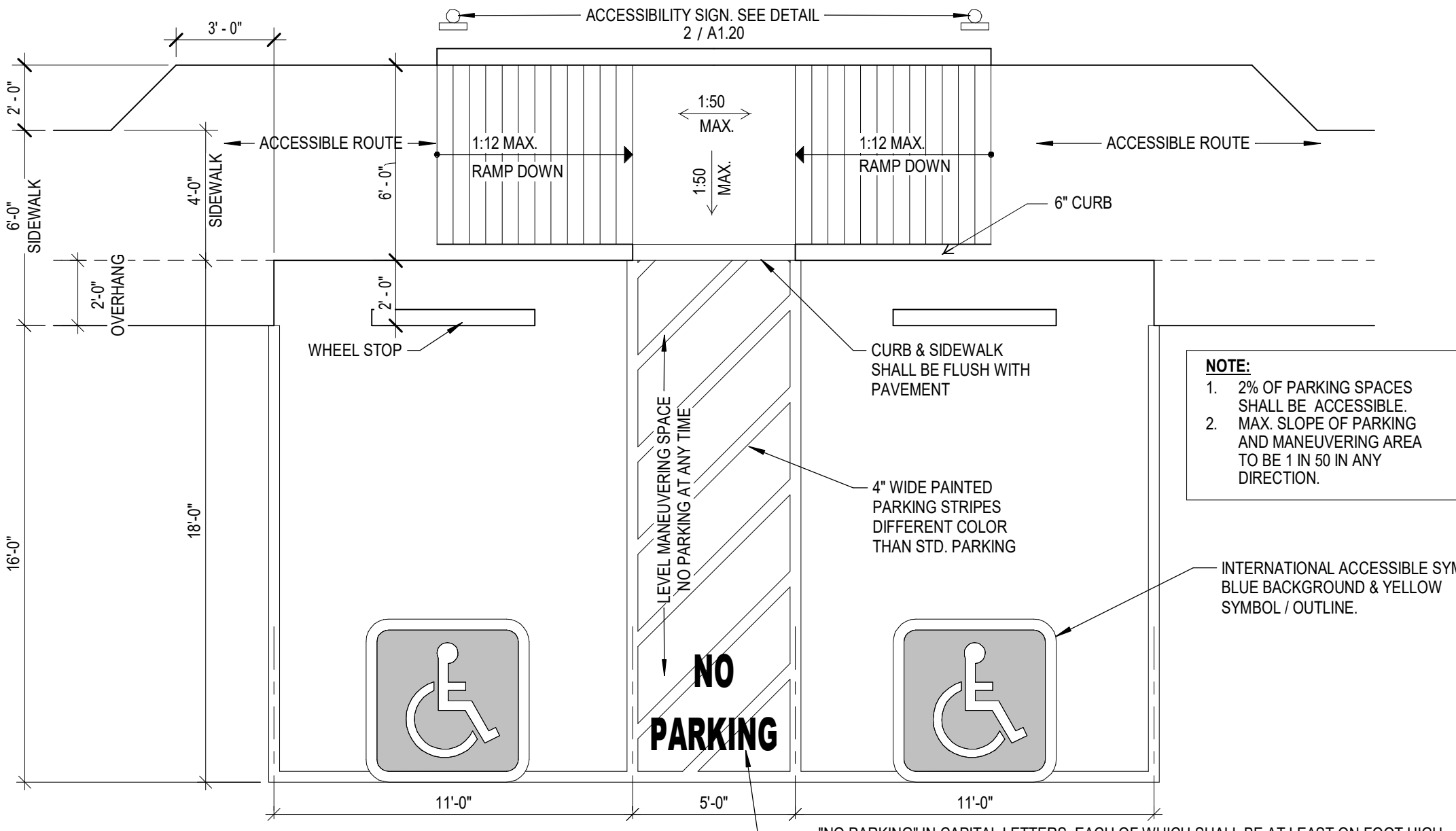

6 TYPICAL ACCESSIBLE PARKING STALL

SCALE: 1/4" = 1'-0"

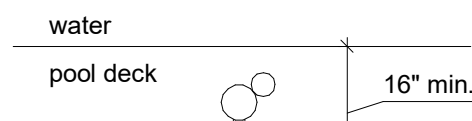

**POOL SEAT LOCATION**

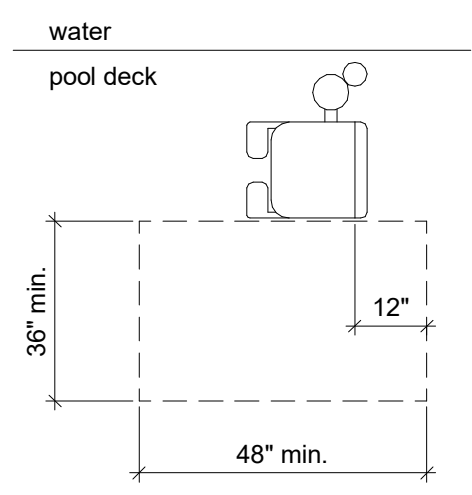

**CLEAR DECK SPACE**

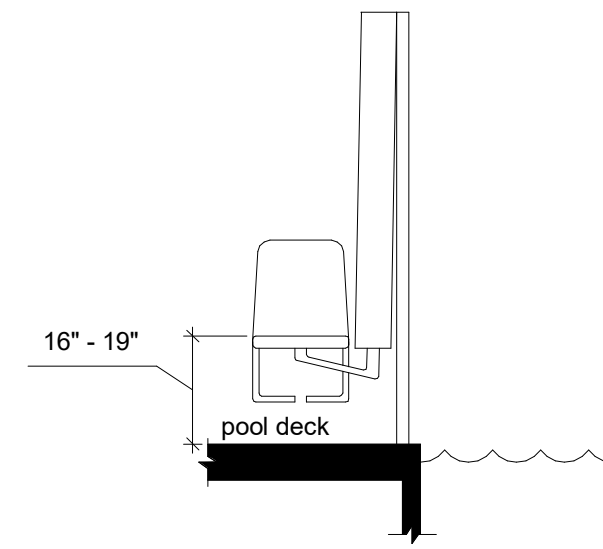

**SEAT HEIGHT**

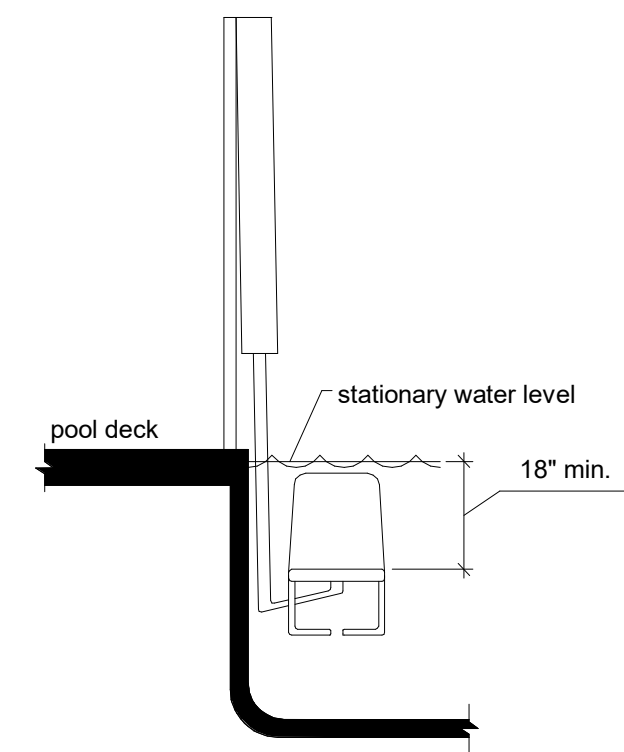

**SUBMERGED DEPTH**

**28 POOL LIFT**

SCALE: 3/8" = 1'-0"

**22 VEHICULAR ENTRY GATE**

SCALE: 3/8" = 1'-0"

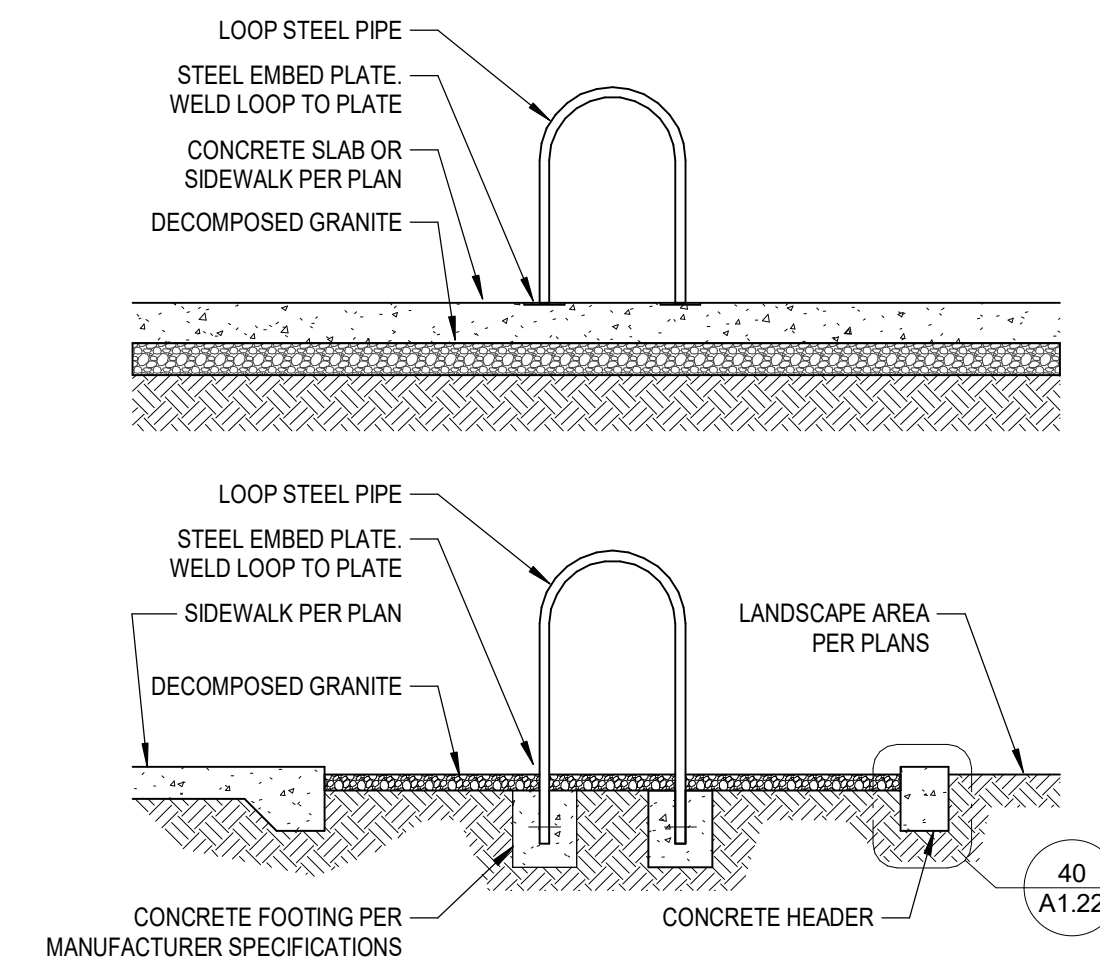

**23 BICYCLE PARKING LOOP**

SCALE: 1/2" = 1'-0"

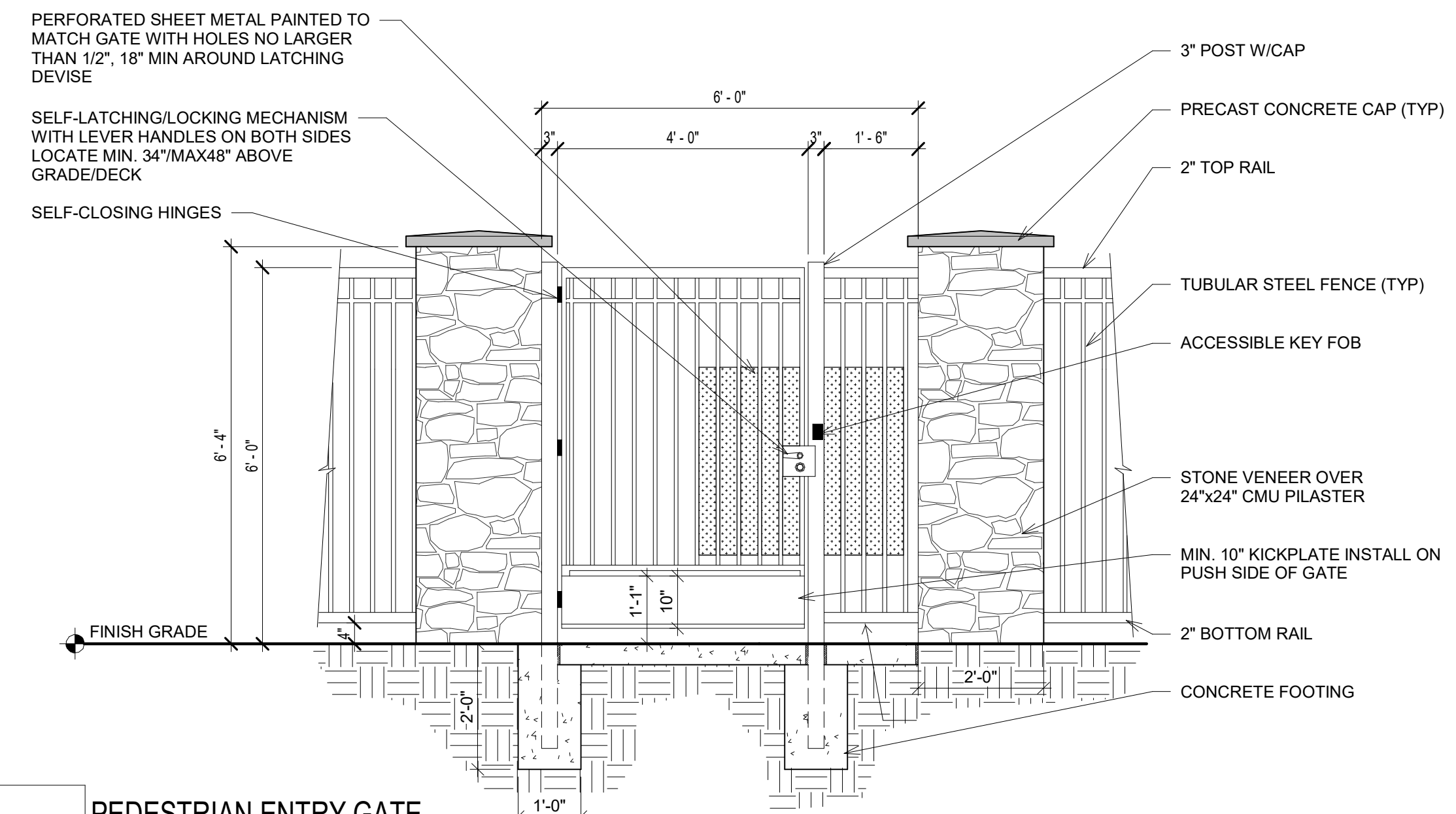

**20 PEDESTRIAN ENTRY GATE**

SCALE: 1/2" = 1'-0"

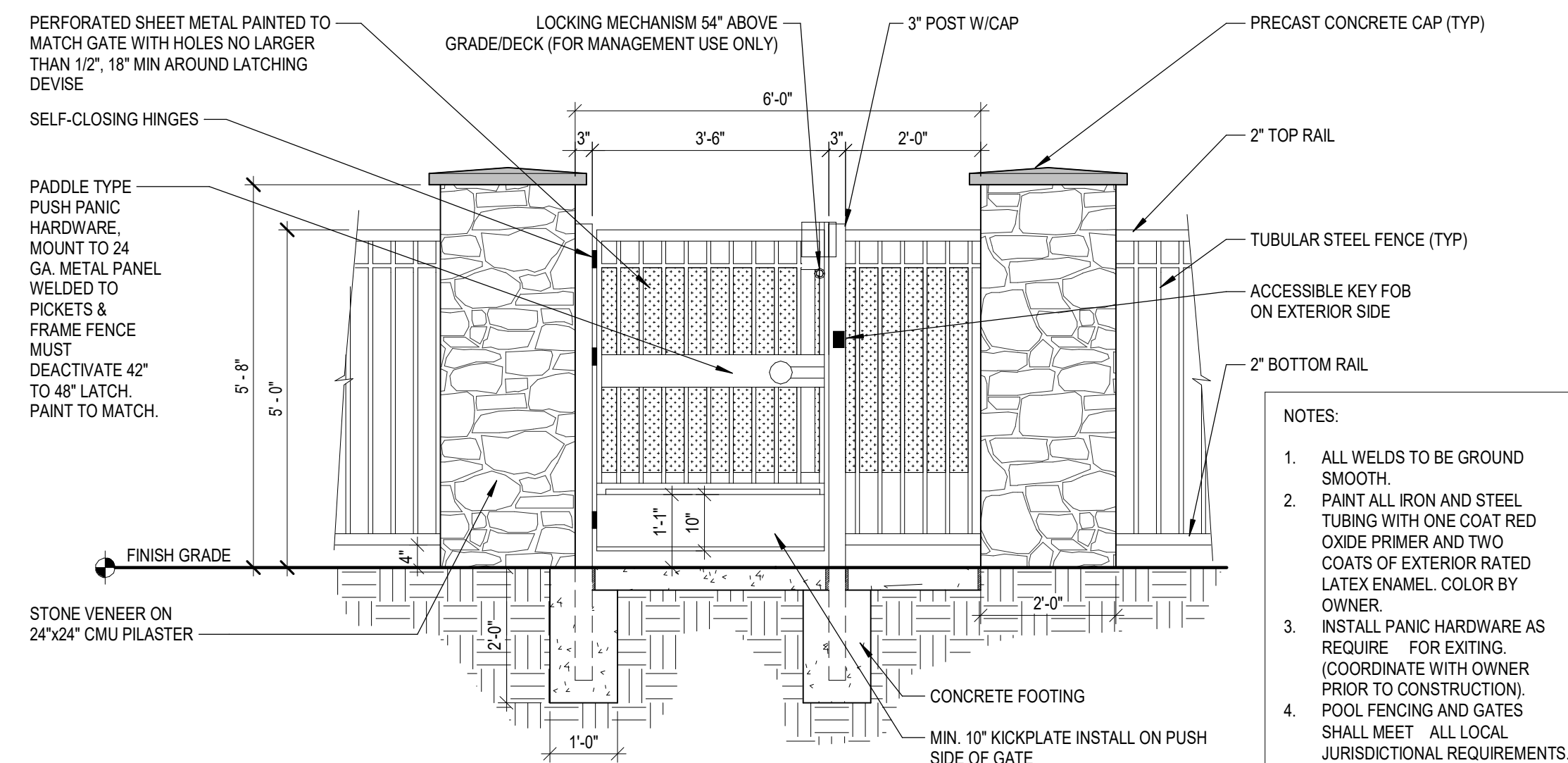

**21 PEDESTRIAN ENTRY GATE AT POOL FENCE**

SCALE: 1/2" = 1'-0"

- NOTES:
1. ALL WELDS TO BE GROUND SMOOTH.
  2. PAINT ALL IRON AND STEEL TUBING WITH ONE COAT RED OXIDE PRIMER AND TWO COATS OF EXTERIOR RATED LATEX ENAMEL. COLOR BY OWNER.
  3. INSTALL PANIC HARDWARE AS REQUIRE FOR EXITING (COORDINATE WITH OWNER PRIOR TO CONSTRUCTION).
  4. POOL FENCING AND GATES SHALL MEET ALL LOCAL JURISDICTIONAL REQUIREMENTS.



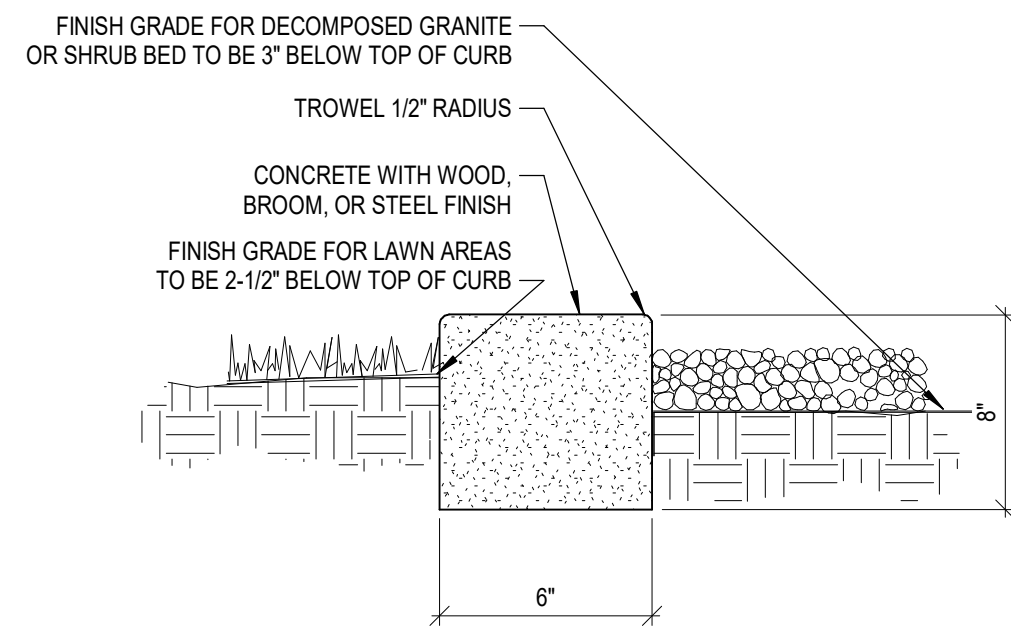

**NOTE:**

1. LANDSCAPE ARCHITECT TO APPROVE FORM WORK PRIOR TO PLACING CONCRETE.
2. HEADER SHOULD BE FLUSH WITH ADJOINING WALK OR CURB.
3. CONCRETE TO BE CLASS A (3000 PSI).
4. EXPANSION JOINTS AT 20'-0" O.C.
5. STRAIGHT SECTIONS TO BE FORMED WITH MIN. OF 2"x6" LUMBER.
6. CURVED SECTIONS TO BE FORMED IN SMOOTH, EVEN CURVES AS SHOWN ON PLAN - FORM WITH 5/8"x6" PLYWOOD.
7. FORM STAKING SHALL NOT ALLOW DEFORMING OF LEAKING - ALL SPILL OR EXCESS CONCRETE SHALL BE CLEANED UP AND REMOVED FROM SITE BY CURB CONTRACTOR.
8. GRADING AT CURB SHALL BE BY CURB CONTRACTOR.

**40 CONCRETE HEADER**

NOT TO SCALE

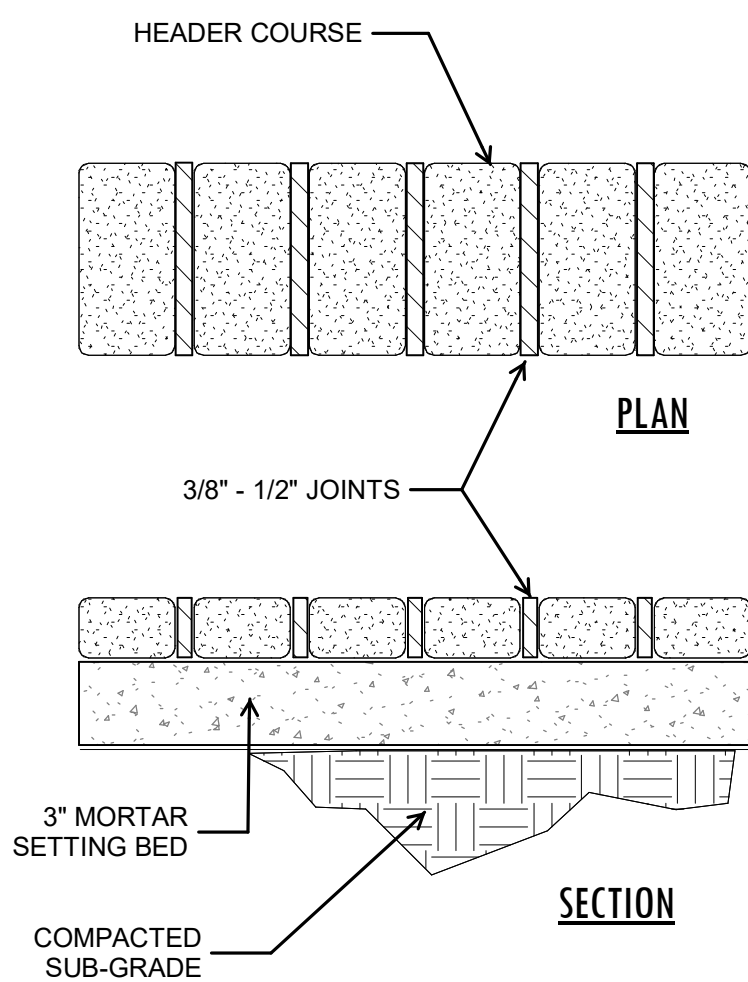

**41 PAVER HEADER**

NOT TO SCALE

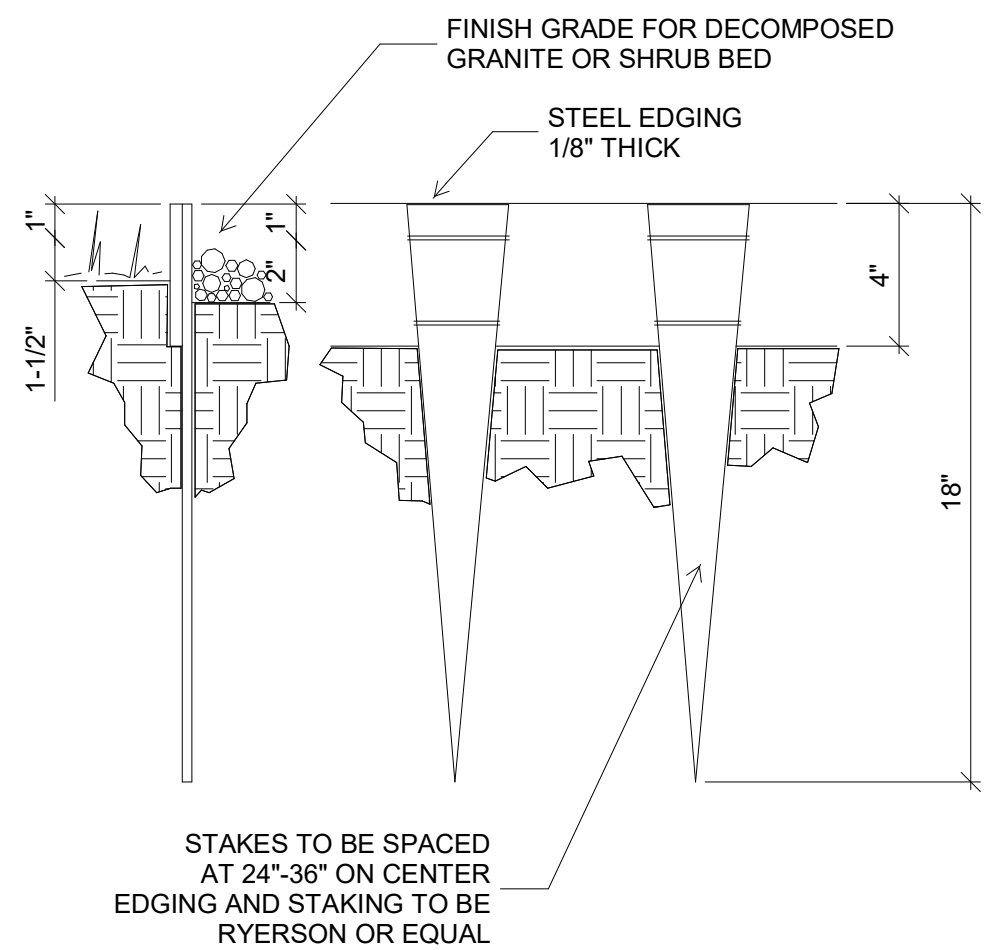

**NOTE:**

1. FINISH GRADE TO BE 3" BELOW TOP OF WALK BEFORE INSTALLATION OF DECOMPOSED GRANITE (2-1/2" FOR SOD OR SEED)

**42 STEEL HEADER**

NOT TO SCALE

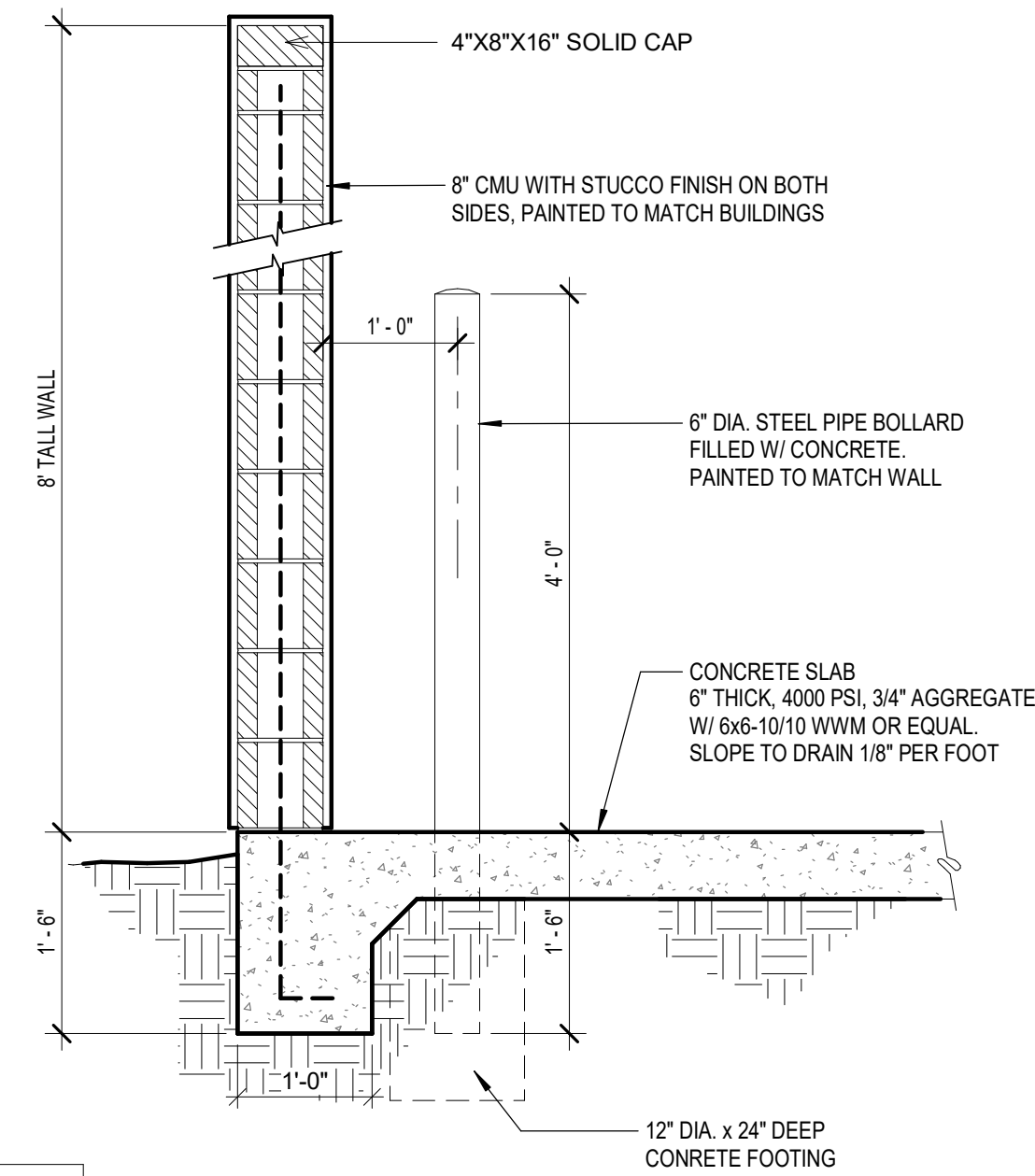

**37 TRASH ENCLOSURE WALL**

SCALE: 3/4" = 1'-0"

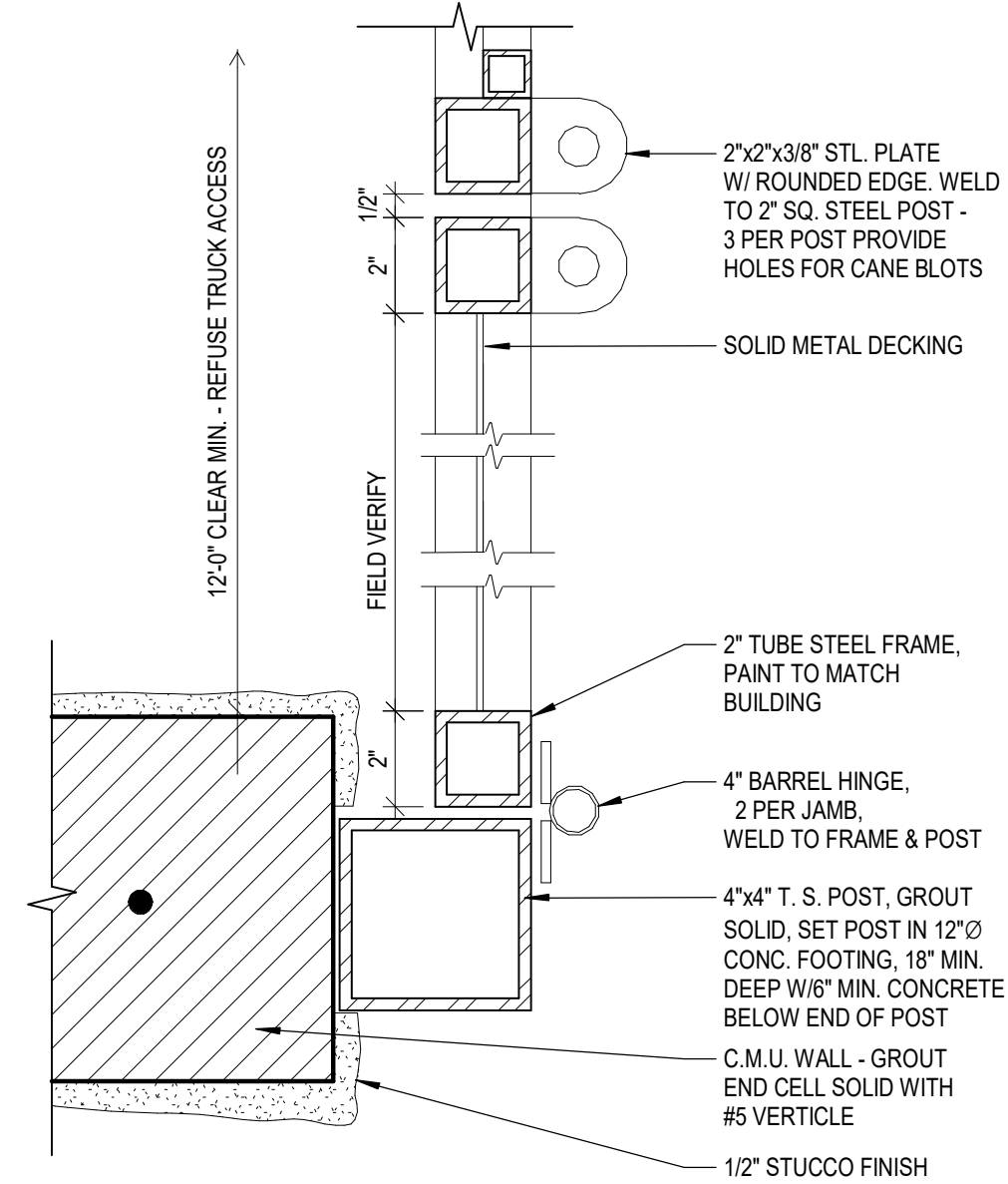

**38 TRASH ENCLOSURE GATE**

SCALE: 3" = 1'-0"

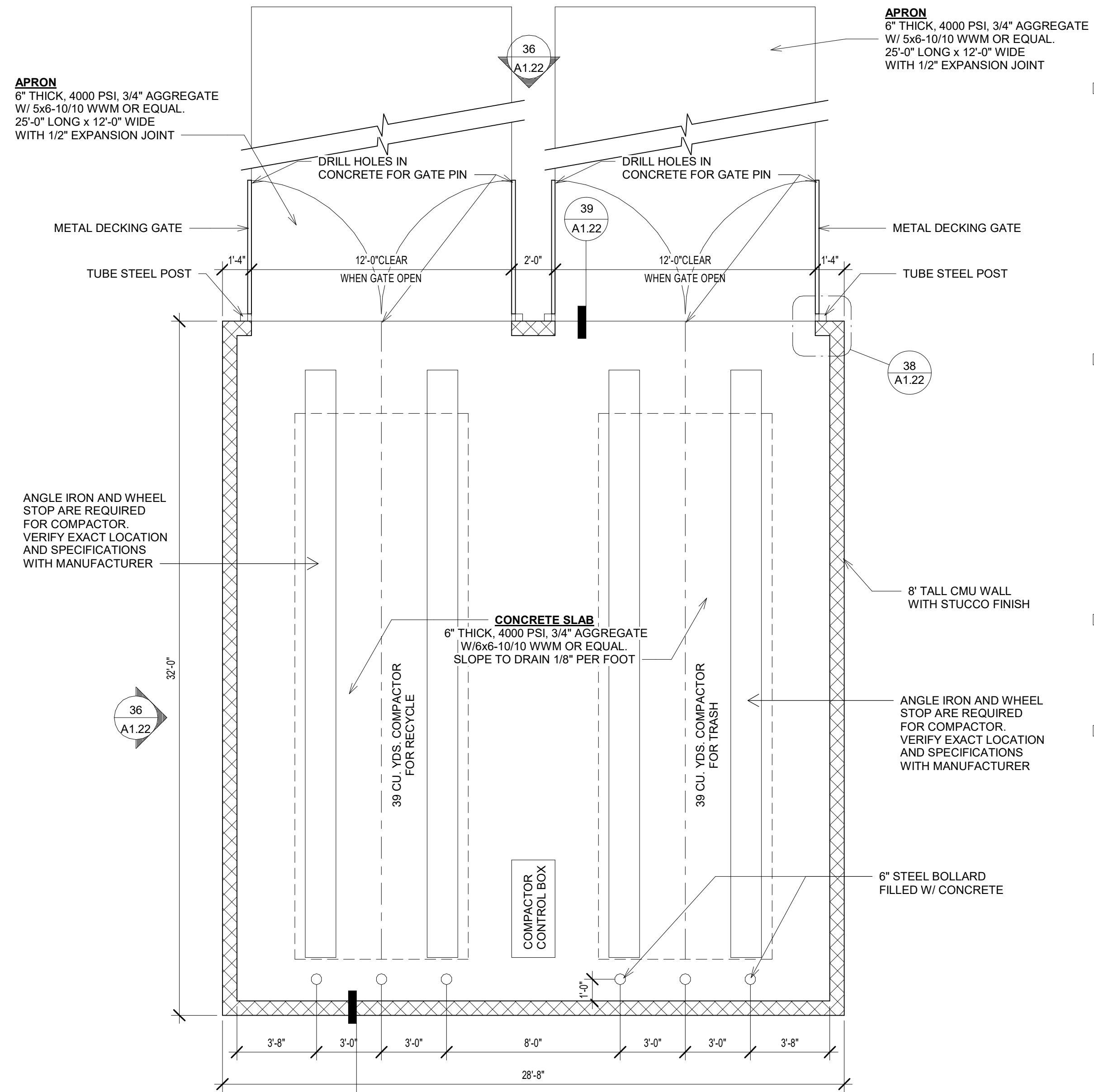

**35 TRASH ENCLOSURE PLAN**

SCALE: 1/4" = 1'-0"

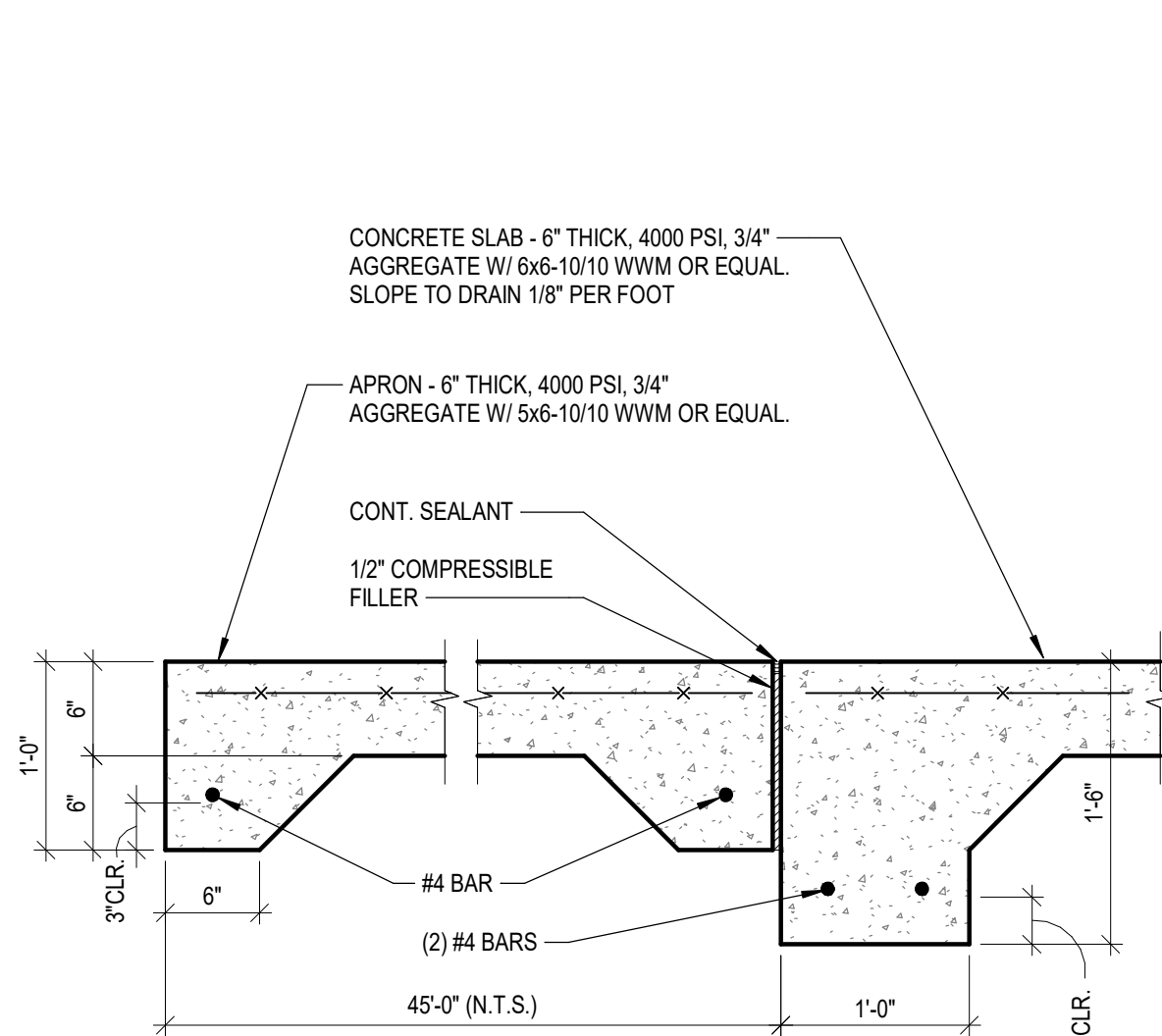

**39 TRASH ENCLOSURE SLAB JOINT**

SCALE: 1" = 1'-0"

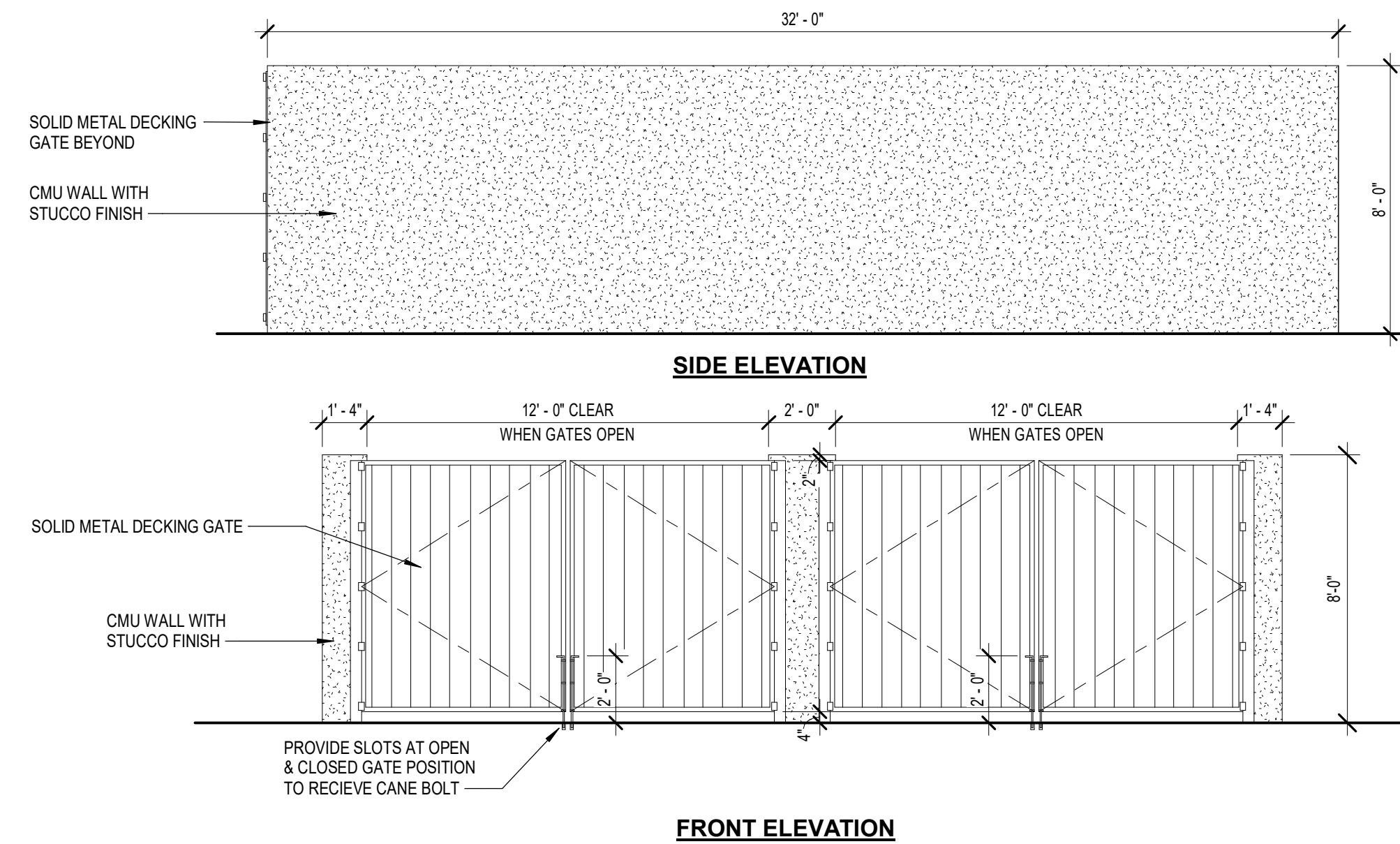

**36 REFUSE ENCLOSURE ELEVATIONS**

SCALE: 1/4" = 1'-0"

**LANDSCAPE CALCULATIONS**

TOTAL AREA OF PROJECT	699,323 SF
LESS BUILDING	371,996 SF
NET LOT AREA	327,327 SF
<b>REQUIRED LANDSCAPE AREA</b>	
MINIMUM 15% OF NET LOT AREA	49,099 SF
ACTUAL LANDSCAPE AREA	148,031 SF
LANDSCAPE AREA REQUIREMENT EXCEEDED	98,932 SF
<b>LANDSCAPE COVERAGE REQUIRED - 75%</b>	
REQUIRED	102,834 SF
ACTUAL PROVIDED	103,291 SF
REQUIREMENT EXCEEDED	457 SF
<b>REQUIRED 25% COVERAGE BY GROUND-LEVEL PLANTS</b>	
REQUIRED	25,708 SF
ACTUAL PROVIDED	29,488 SF
REQUIREMENT EXCEEDED	3,780 SF
<b>SOD ALLOWED (10%)</b>	
REQUIRED	10,283 SF
ACTUAL PROVIDED	10,204 SF
<b>PARKING LOT TREES (1 TREE PER 10 PARKING SPACES)</b>	
380 PARKING SPACES PROVIDED	
REQUIRED (380 / 10)	38 TREES
PROVIDED	56 TREES
<b>PARKING LOT AREA</b>	
REQUIRED LANDSCAPE AREA 15%	201,167 SF
ACTUAL LANDSCAPE AREA	30,175 SF
ACTUAL LANDSCAPE AREA	31,704 SF
<b>STREET TREES REQUIRED (1 TREE PER 30 LF)</b>	
<ul style="list-style-type: none"> <li>SAN ANTONIO DRIVE NE IS NOT CONSIDERED AN ARTERIAL OR COLLECTOR PER THE LONG RANGE ROADWAY SYSTEM 2040 MAP NOR IS THE STREET WITHIN 20' OF THE PROPERTY.</li> <li>TRAMWAY BOULEVARD NE IS NOT WITHIN 20' OF THE PROPERTY.</li> </ul>	
<b>DWELLING UNIT TREES REQUIRED</b>	
(1 TREE PER 1ST STORY UNIT + 1 TREE PER 2ND STORY UNIT. 281 UNITS TOTAL)	281 TREES
PROVIDED	313 TREES

THIS IS A GENERAL CONCEPT AND IS SUBJECT TO REFINEMENT AS THE PROJECT DESIGN PROGRESSES.



**REFERENCE NOTES SCHEDULE**





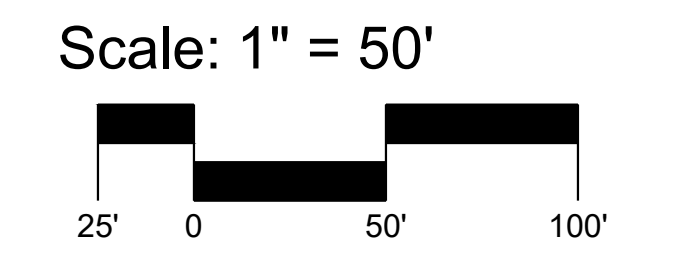
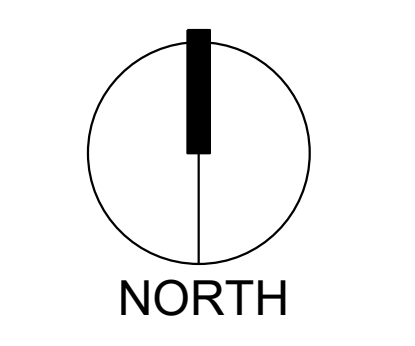
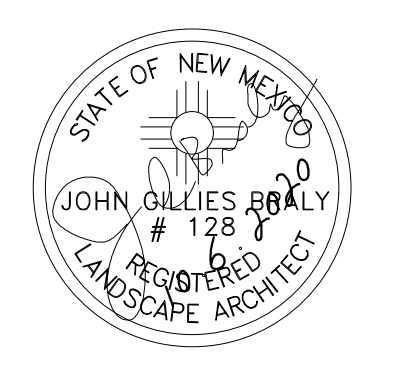







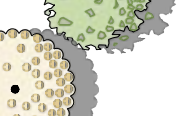
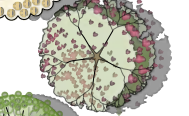
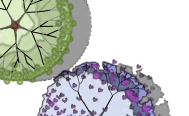
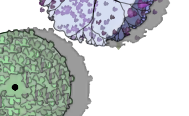



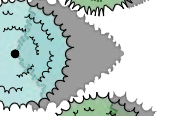

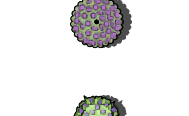
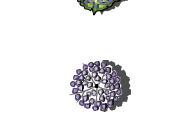
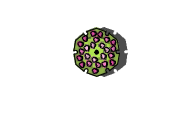

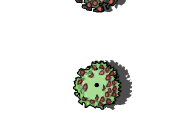

SYMBOL	DESCRIPTION	QTY	DETAIL
	BOULDER	24	
	GRAVEL MULCH	126,488 SF	
	GRASS	10,204 SF	
	REVEGETATION SEEDING	28,503 SF	
	NATURAL PATH	7,756 SF	
	FLOWERS	356 SF	
	GRAVEL MULCH2	6,269 SF	
	PARKING LOT AREA		

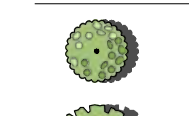
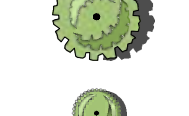
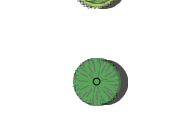
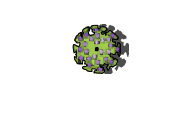
SEE SHEET LP-02 FOR PLANT LEGEND



Landscape Plan

# PLANT SCHEDULE

DECIDUOUS TREES	QTY	BOTANICAL / COMMON NAME	SIZE	WATER USAGE	H X W
	54	CHILOPSIS LINEARIS / DESERT WILLOW	2" B&B	RW	20' X25'
	11	COTINUS COGGYGRIA / SMOKE TREE	2" B&B	MEDIUM	15' X 15'
	46	FORESTIERA NEOMEXICANA / NEW MEXICAN PRIVET	24" BOX	MEDIUM	15' X15'
	27	FRAXINUS AMERICANA 'JUNGINGER' TM / AUTUMN PURPLE WHITE ASH	2" B&B	MEDIUM +	30' X30'
	9	LAGERSTROEMIA INDICA / CRAPE MYRTLE	2" B&B	HIGH	15' X 15'
	36	PISTACIA CHINENSIS / CHINESE PISTACHE	2" B&B	MEDIUM	40' X 40'
	18	PRUNUS CERASIFERA 'THUNDERCLOUD' / THUNDERCLOUD PURPLELEAF PLUM	2" B&B	LOW +	15' X12'
	12	QUERCUS / OAK	2" B&B	MEDIUM	40' X 40'
	40	ULMUS PARVIFOLIA 'ALLEE' / ALLEE LACEBARK ELM	2" B&B	MEDIUM	40' X 40'
	14	VITEX AGNUS-CASTUS / CHASTE TREE	24" BOX	MEDIUM	20' X20'
	27	PINUS NIGRA / AUSTRIAN BLACK PINE	2" B&B	MEDIUM +	25' X 35'
	8	CEDRUS ATLANTICA 'GLAUCA PENDULA' / WEEPING BLUE ATLAS CEDAR	4'-6'	MEDIUM +	15' X15'
	11	JUNIPERUS SCOOPULORUM / ROCKY MOUNTAIN JUNIPER	2" B&B	LOW +	40' X 20'
	11	CARYOPTERIS X CLANDONENSIS 'DARK KNIGHT' / BLUE MIST SPIREA	1 GAL	LOW+	3' X 3'
	131	PEROVSKIA ATRIPLICIFOLIA / RUSSIAN SAGE	5 GAL	MEDIUM	5' X 5'
	59	POTENTILLA FRUTICOSA / BUSH CINQUEFOIL	5 GAL	MEDIUM+	3' X 3'
	43	RHUS AROMATICA 'GRO-LOW' / GRO-LOW FRAGRANT SUMAC	5 GAL	LOW+	2' X 6'
	66	ROSA X 'KNOCKOUT' TM / ROSE	5 GAL	MEDIUM	6' X 5'
	79	SALVIA GREGGII / AUTUMN SAGE CHERRY	1 GAL	LOW+	2' X 3'
	41	HESPERALOE PARVIFLORA 'YELLOW' / YELLOW YUCCA	5 GAL	LOW+	4' X 5'
	52	NOLINA MICROCARPA / BEARGRASS	5 GAL	RW	5' X 6'
	25	YUCCA GLAUCA / SOAPWEED	5 GAL	RW	3' X 3'
	175	CERCOCARPUS LEDIFOLIUS / CURL-LEAF MOUNTAIN MAHOGANY	5 GAL	LOW+	12' X 8'
	93	COTONEASTER PARNEYI / COTONEASTER	5 GAL	MEDIUM	8' X 10'
	119	ERICAMERIA LARICIFOLIA / TURPENTINE BUSH	5 GAL	LOW	3' X 4'
	66	JUNIPERUS SABINA 'BUFFALO' / BUFFALO JUNIPER	5 GAL	LOW+	1' X 4'
	59	LAVANDULA ANGUSTIFOLIA / ENGLISH LAVENDER	1 GAL	MEDIUM	3' X 3'
	35	NANDINA DOMESTICA / HEAVENLY BAMBOO	5 GAL	MEDIUM+	8' X 5'
	64	PHOTINIA X FRASERI / RED TIP PHOTINIA	5 GAL	MEDIUM+	8' X 8'
	46	RHAPHIOLEPIS INDICA / INDIAN HAWTHORN	5 GAL	MEDIUM	3' X 4'
	134	MUHLLENBERGIA RIGIDA / PURPLE MUHLY	5 GAL	LOW+	2' X 3'
	211	CALAMAGROSTIS X ACUTIFLORA 'KARL FOERSTER' / FEATHER REED GRASS	1 GAL	MEDIUM	30' X 24'
	43	LONICERA JAPONICA 'HALLIANA' / HALLS HONEYSUCKLE FLOWERING VINE	5 GAL	MEDIUM+	CLIMBING + 12'

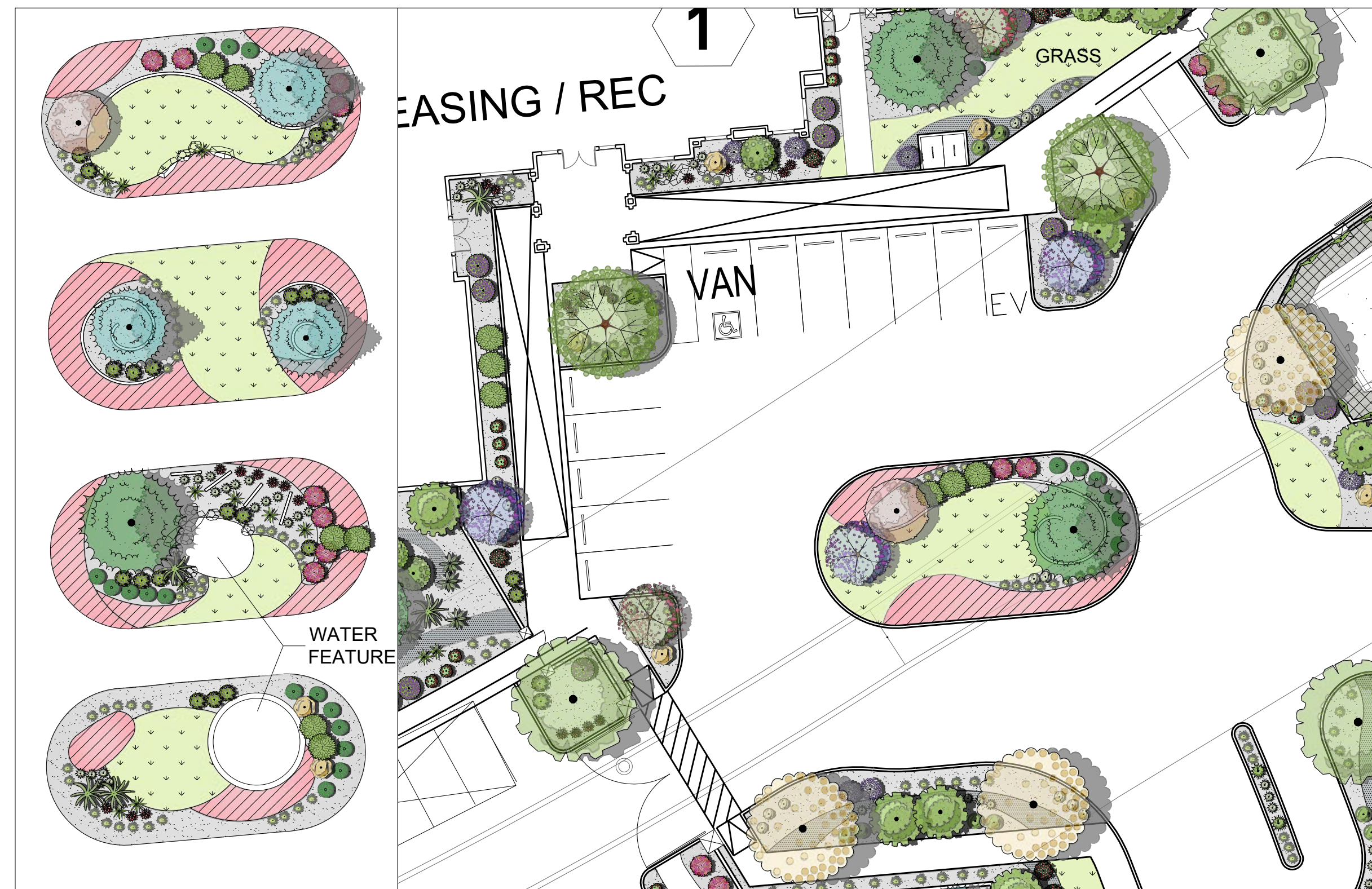

ENTRY EXHIBITS

ENTRY

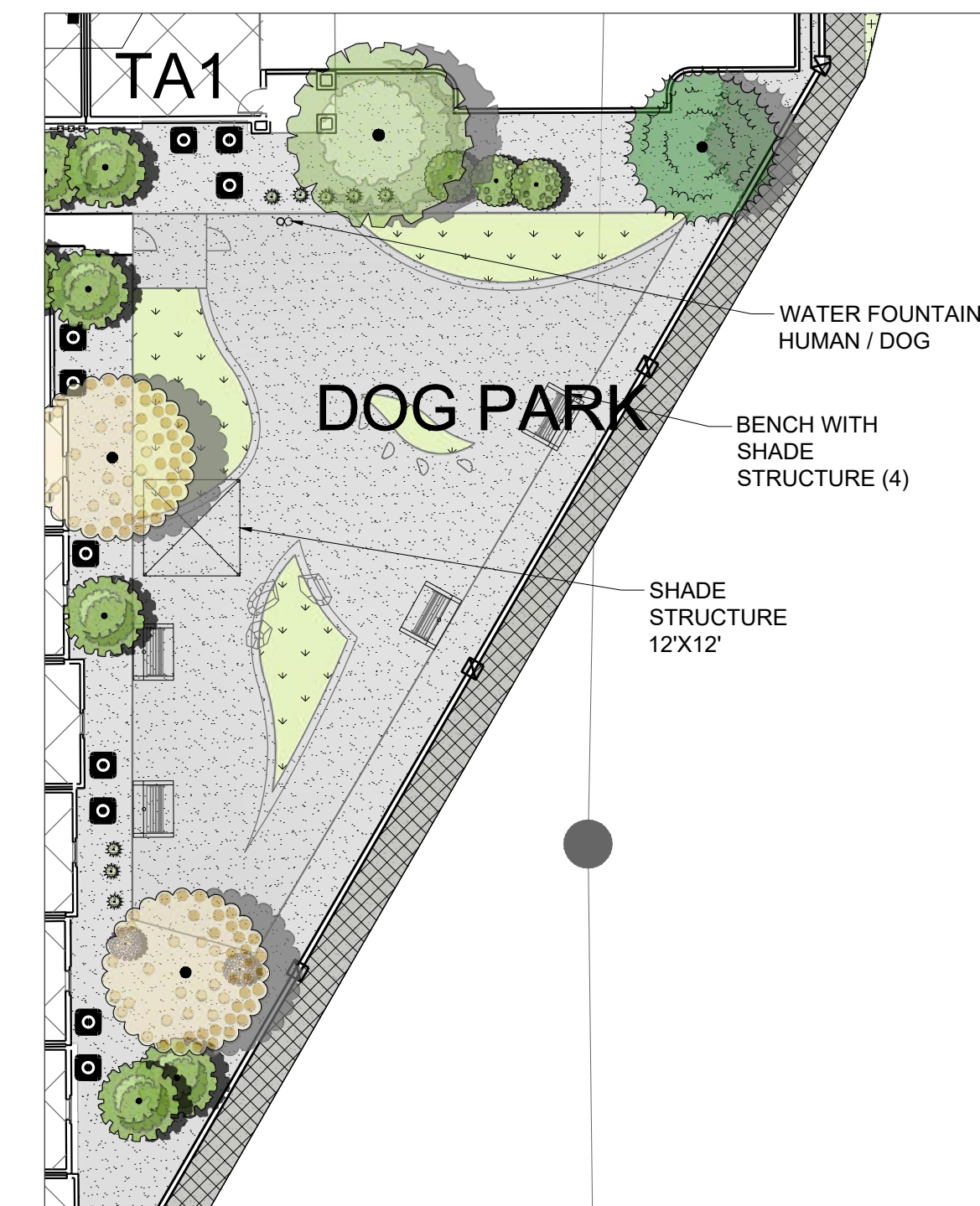

DOG PARK

MEMORIAL PARK

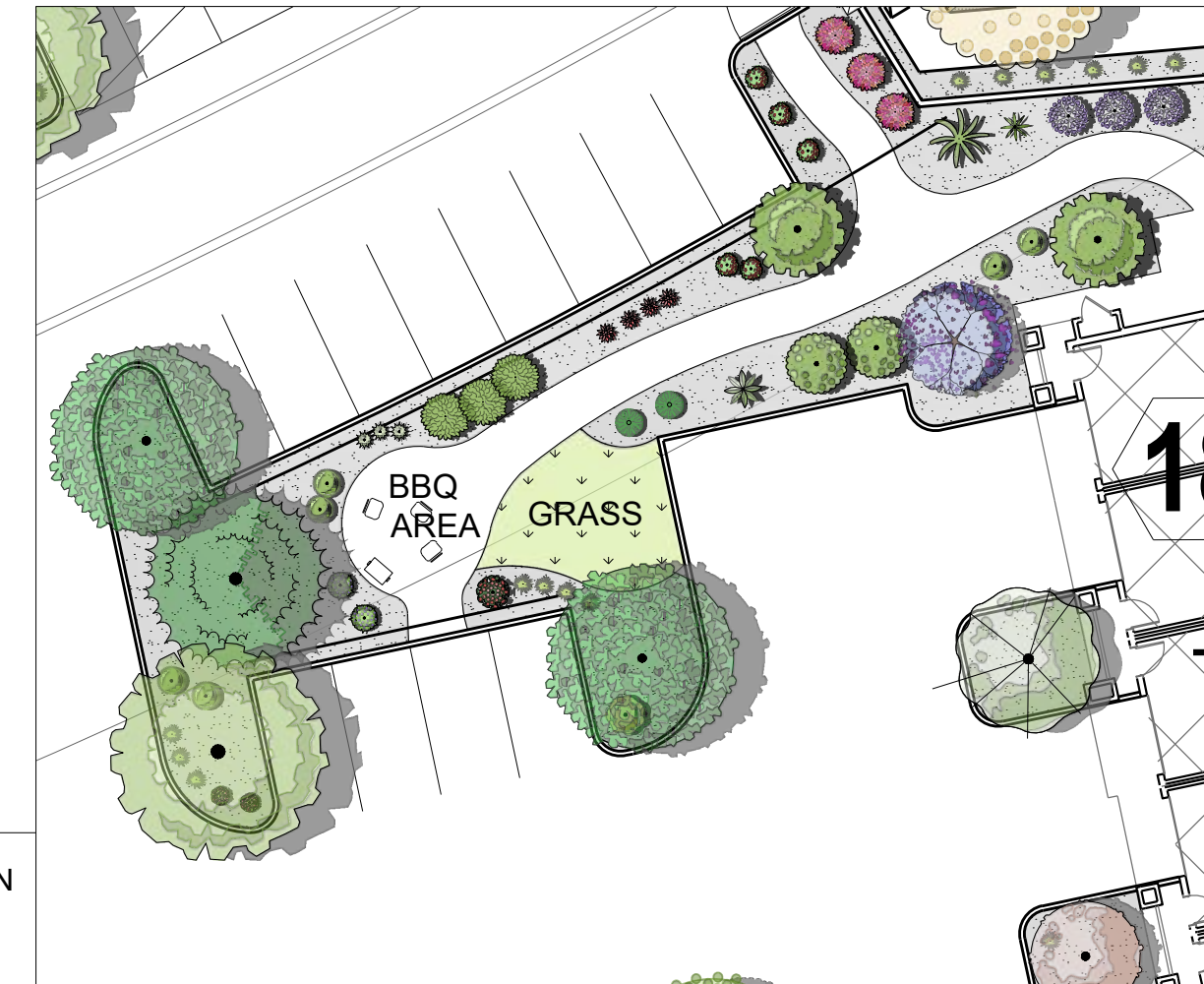

BBQ AREA

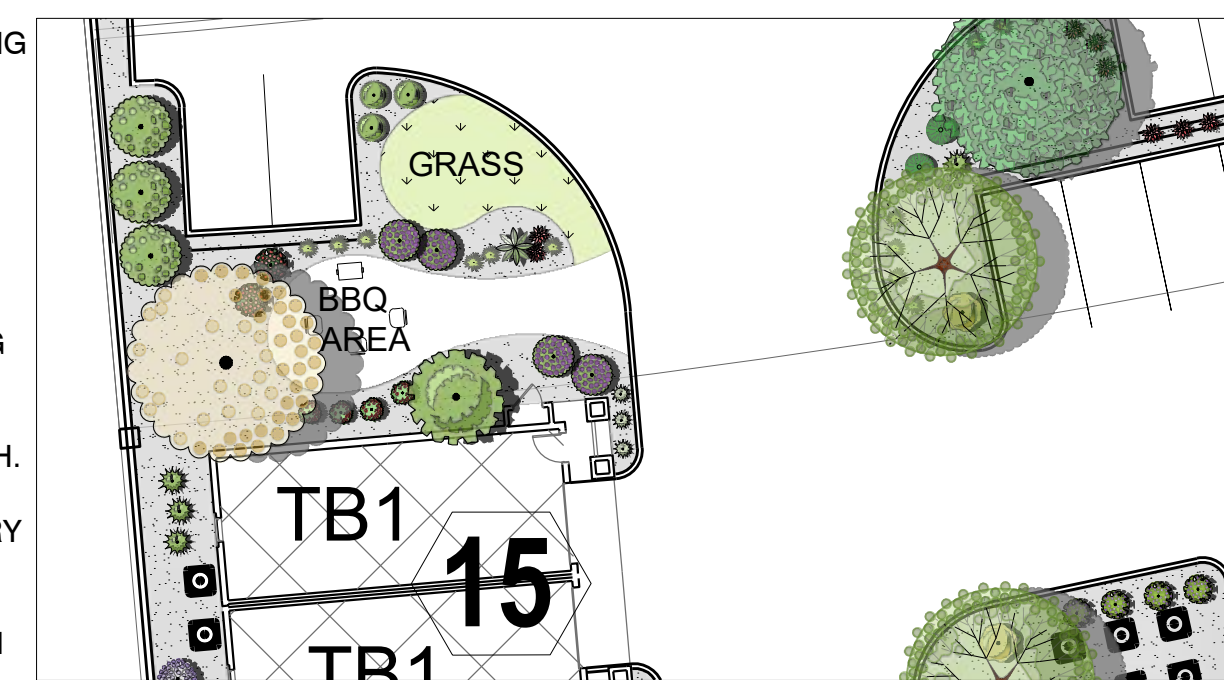

BBQ AREA



BBQ AREA

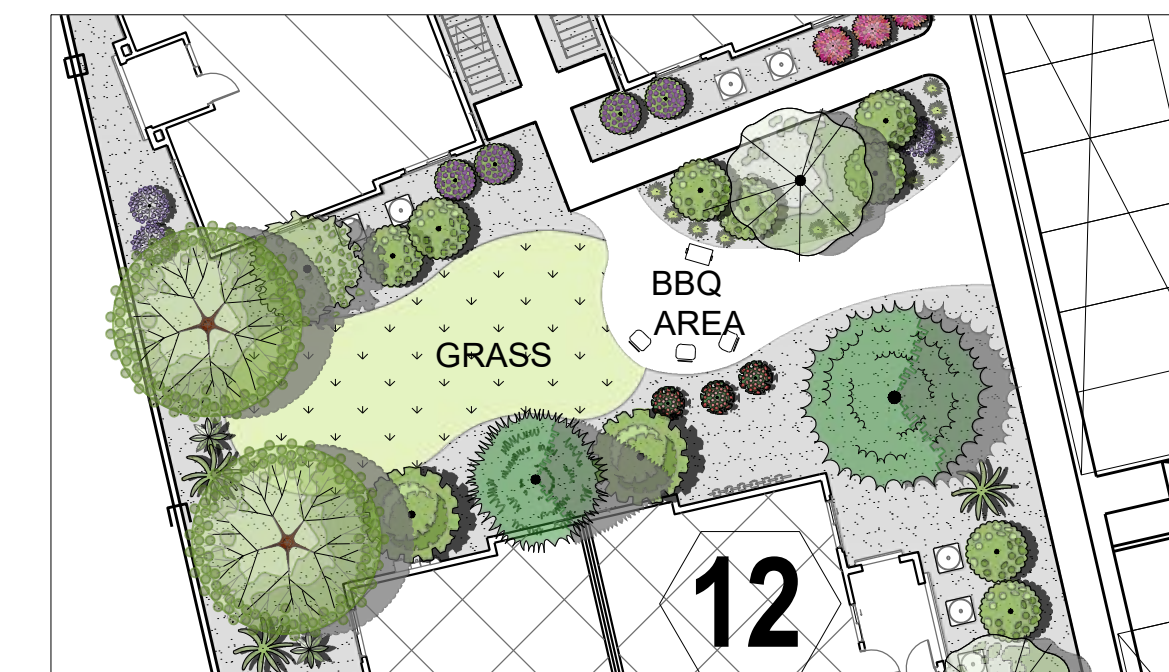
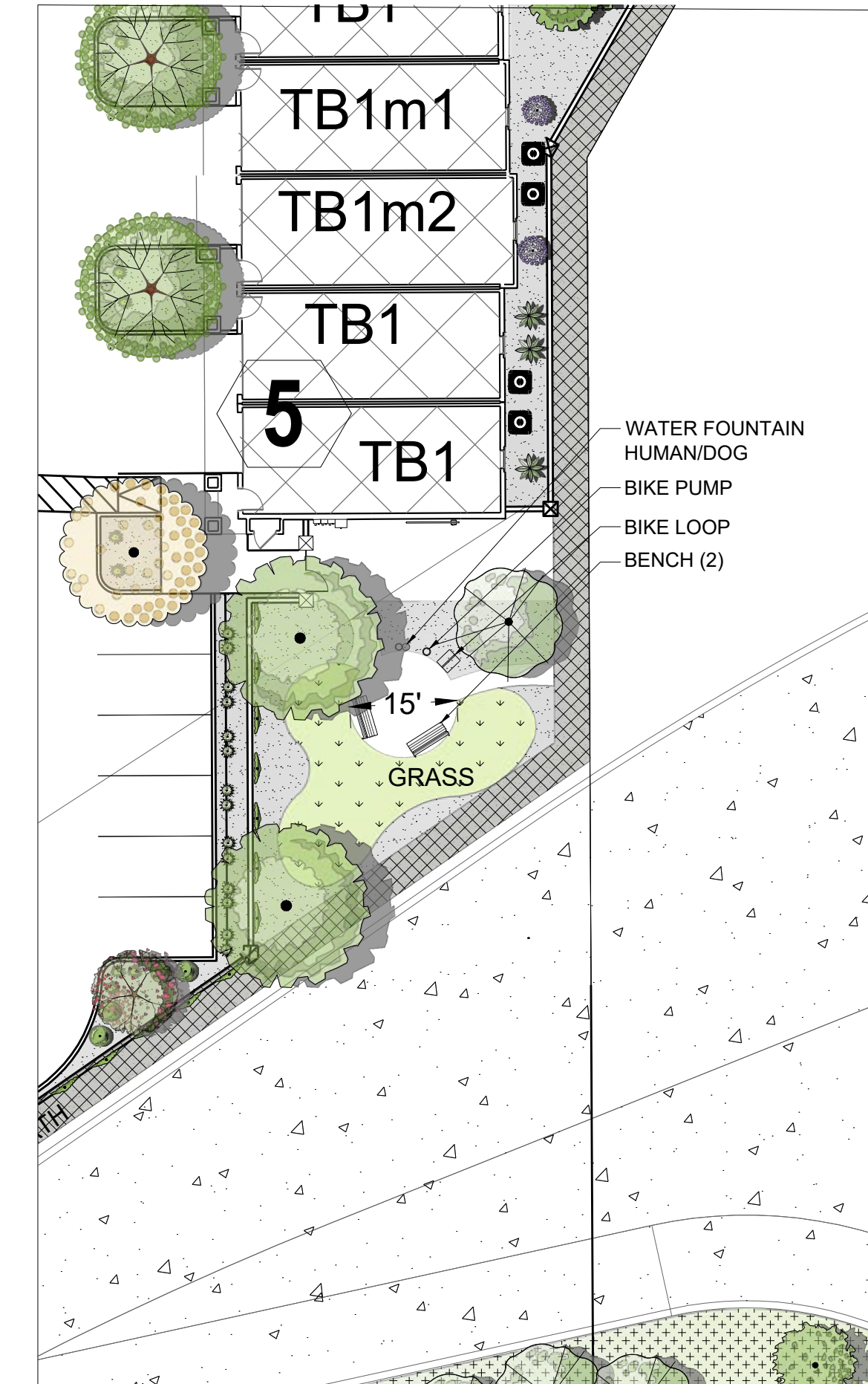

BBQ AREA

## GENERAL LANDSCAPE NOTES

- CONTRACTOR TO VERIFY EXISTING UTILITY LOCATIONS BEFORE EXCAVATION AND PLANTING.
- RESPONSIBILITY FOR MAINTENANCE: THE CONTRACTOR WILL BE RESPONSIBLE FOR MAINTENANCE OF THE LANDSCAPE DURING CONSTRUCTION AND DURING A 90 DAY-MAINTENANCE PERIOD FOLLOWING SUBSTANTIAL COMPLETION. THE OWNER WILL BE RESPONSIBLE FOR MAINTENANCE FOLLOWING THE 90-DAY MAINTENANCE PERIOD. THE PROPERTY OWNER SHALL MAINTAIN RIGHT-OF-WAY (ROW) LANDSCAPING IN A NEAT AND HEALTHY CONDITION.
- STATEMENT OF COMPLIANCE WITH CITY OF ALBUQUERQUE: THE LANDSCAPING SHALL COMPLY WITH THE CITY OF ALBUQUERQUE ZONING CODE INCLUDING, BUT NOT LIMITED TO, GENERAL LANDSCAPING REGULATIONS, WATER CONSERVATION LANDSCAPING AND WATER WASTE REGULATIONS, POLLEN-RELATED REGULATIONS, MINIMUM VEGETATIVE COVERAGE REQUIREMENTS AND STREET TREE REGULATIONS.
- TIMING OF LANDSCAPE INSTALLATION: INSTALLATION OF THE LANDSCAPING SHALL BE COMPLETE WITHIN 60 DAYS OF THE RELATED BUILDING'S OCCUPANCY.
- SURFACE TREATMENT: LANDSCAPE AREAS SHALL BE COVERED WITH MULCH. LANDSCAPE, FENCING, AND SIGNING WILL NOT INTERFERE WITH CLEAR SIGHT REQUIREMENTS. THEREFORE, SIGNS, WALLS, TREES, AND SHRUBBERY BETWEEN 3' AND 8' (AS MEASURED FROM THE GUTTER PAN) WILL NOT BE ACCEPTABLE IN THIS AREA.
- LANDSCAPING WILL BE WATERED WITH AN AUTOMATED IRRIGATION SYSTEM THAT INCLUDES DRIP ZONES FOR LANDSCAPING.
- MINIMUM PLANT SIZES ARE AS PER CITY OF ALBUQUERQUE STANDARDS: 2" CALIPER TREES, 6" HEIGHT CONIFERS, AND 1 GALLON SHRUBS.
- AREAS DISTURBED DURING CONSTRUCTION, INCLUDING AREAS NOT WITHIN THE PROPERTY LINE, WILL BE STABILIZED.
- ROOF DRAINS: SURFACE DRAINAGE OFF DOWNSPOUTS SHALL BE DIRECTED AWAY FROM BUILDINGS INTO LANDSCAPE AREAS OR ENGINEERED DRAINAGE SYSTEMS. REFER TO CIVIL.
- VEGETATIVE SCREENING SURROUNDING GROUND-MOUNTED TRANSFORMERS AND UTILITY PADS SHALL ALLOW 10' OF CLEARANCE IN FRONT OF THE EQUIPMENT DOOR AND 5' OF CLEARANCE ON THE REMAINING SIDES FOR SAFE OPERATION AND MAINTENANCE.
- NEW PLANTINGS DO NOT INCLUDE HIGH WATER TURF.
- ORGANIC BARK MULCH IS PROVIDED AT EACH TREE FROM ROOT BALL EXTENDING OUT TO DRIPLENE PER CITY OF ALBUQUERQUE IDO 14-16-5-6(C)(5)(b)
- WHERE MULCH IS ADJACENT TO CONCRETE OR ASPHALT, FINISH GRADE OF MULCH SHALL 1/2" BELOW TOP OF CONCRETE, UNLESS OTHERWISE INDICATED.
- PLANT MATERIAL SHALL BE FREE OF DISEASE AND INSECTS AND SHALL CONFORM TO THE AMERICAN STANDARD FOR NURSERY STOCK (ASNA) OF THE AMERICAN NURSERY AND LANDSCAPE ASSOCIATION.
- ALL LANDSCAPING CONTIGUOUS TO INDIGENOUS AREAS TO BE PLANTED WITH INDIGENOUS TREES AND SHRUBS.

## ALLASO HIGH DESERT

S.W. TENNYSON STREET AND SAN ANTONIO DR.  
Albuquerque, New Mexico

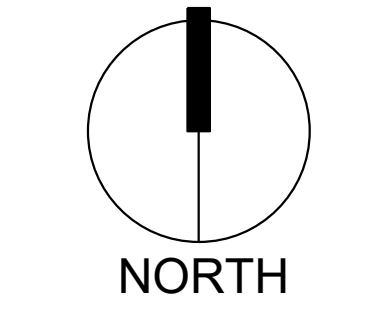
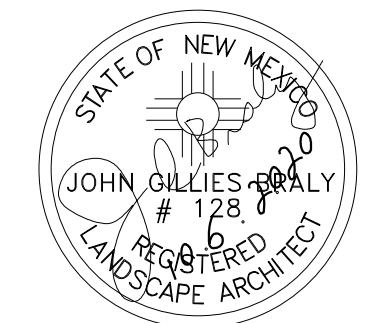

Scale: 1" = 20'

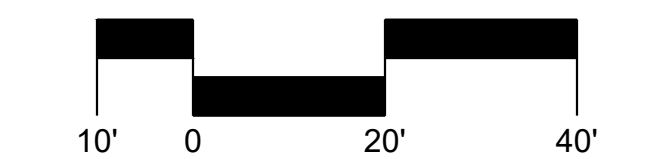

## Landscape Plan

DRB SUBMITTAL

DATE: OCTOBER 5, 2020 ORB #19-209  
OCTOBER 6, 2020

# LP-02

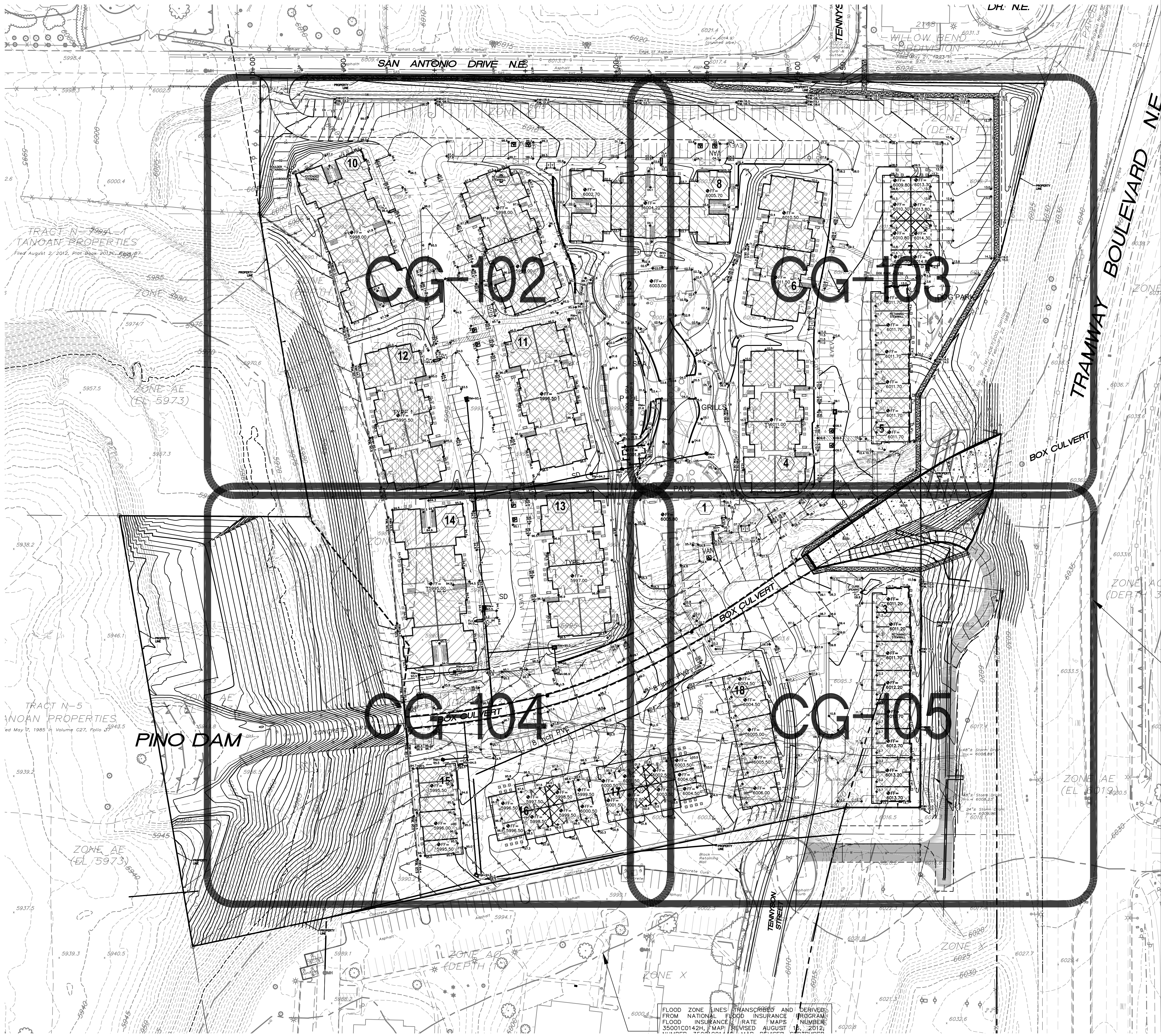

### NOTES

- A. THIS SHEET IS A KEY FOR THE GRADING SHEETS FOLLOWING.
- B. CALCULATIONS ARE PROVIDED SEPARATELY WITHIN THE SUPPLEMENTAL INFORMATION PACKET.
- C. NOT ALL KEYED NOTES WILL BE USED ON EVERY SHEET.
- D. ALL ELEVATIONS SHOWN ARE TOP OF THE DESIGNED MATERIAL SUCH AS ASPHALT PAVING, SIDEWALK, FINISHED FLOOR, LANDSCAPING, ETC. THE CONTRACTOR SHALL GRADE TO TOP OF SUBGRADE ELEVATION AS NEEDED.
- E. ALL PRIVATE CURBS ARE 6" HIGH. WHERE ONLY FLOWLINE ELEVATIONS ARE SHOWN, TOP OF CURB ELEVATIONS ARE 0.5' HIGHER.
- F. STORM WATER QUALITY VOLUME WILL BE ADDRESSED BY FEE-IN-LIEU WITHIN THE PINO DAM POOL.
- G. PINO ARROYO CONCRETE BOX CULVERT, OPEN CHANNEL, PUBLIC STORM DRAIN, AND MAINTENANCE ACCESS ROAD TO BE CONSTRUCTED PER PUBLIC WORK ORDER PLANS (CPN 502980) BY SEPARATE CONTRACT. ALL GRADES ARE AT LEAST 1.0' ABOVE THE TOP OF BOX CULVERT. IF DISCREPACIES ARE FOUND, CONTACT THE ENGINEER IMMEDIATELY.
- H. WORK WITHIN TENNYSON ST AND SAN ANTONIO DR PUBLIC RIGHT-OF-WAY TO BE CONSTRUCTED PER PUBLIC WORK ORDER PLANS BY SEPARATE CONTRACT.
- I. WORK WITHIN NMDOT RIGHT-OF-WAY TO BE PERMITTED BY NMDOT. CONTRACTOR TO CONTACT NMDOT PRIOR TO GRADING OPERATIONS.
- J. WORK WITHIN PINO DAM POOL TO BE INSPECTED BY AMAFCA. CONTACT AMAFCA PRIOR TO GRADING OPERATIONS.

## ALLASO HIGH DESERT

SWC TENNYSON STREET AND SAN ANTONIO DR.  
Albuquerque, New Mexico

Office of Rich Barber  
**ORB**  
 Architecture, LLC  
 WorldHQ@ORBArch.com



Contractor must verify all dimensions at project before proceeding with this work.  
 Do not reproduce these drawings and specifications without the expressed written permission of the architect. The drawings and specifications are instruments of service and shall remain the property of the architect whether the project for which they are made is executed or not. These drawings and specifications shall not be used by anyone on any other project, for additions to this project, or for completion of this project by others except by the expressed written permission of the architect.  
 © ORB Architecture, LLC 2015

### REVISIONS

### EPC SUBMITTAL

DATE: JULY 28, 2020 ORB # 19-209

### OVERALL GRADING & DRAINAGE PLAN

CG-101

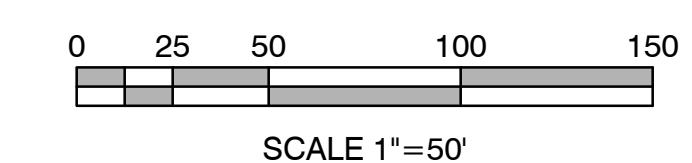

- 60.30- EXISTING CONTOUR
- 6029.4 EXISTING SPOT ELEVATION
- 65 PROPOSED 1.0' CONTOUR
- - - - -65.5- - - - - PROPOSED 0.5' CONTOUR
- ◆65.4 PROPOSED SPOT ELEVATION
- FLOW DIRECTION
- FF = 4966.00 FINISH FLOOR ELEVATION
- ====○==== EXISTING STORM DRAIN / MANHOLE
- PROPOSED STORM DRAIN / INLET

FLOOD ZONE LINES TRANSCRIBED AND DERIVED FROM NATIONAL FLOOD INSURANCE PROGRAM FLOOD INSURANCE RATE MAPS NUMBER 35001C01424, MAP REVISED AUGUST 1, 2012.







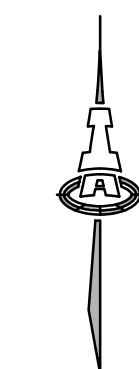



**KEYED NOTES**

1. PAVING TO BE INSTALLED AT GRADES SHOWN. SEE PAVING PLAN FOR PAVING SECTIONS.
2. CONCRETE SIDEWALK AND FLATWORK INSTALLED AT ELEVATIONS SHOWN. 5.0% MAXIMUM LONGITUDINAL SLOPE, 2.0% MAXIMUM CROSS-SLOPE. SEE ARCHITECTURAL SITE PLAN FOR DETAILS.
3. INSTALL RETAINING WALL WITH GROUND ELEVATIONS SHOWN IN THIS PLAN AT TOP AND BOTTOM OF RETAINING. SEE ARCHITECTURAL SITE PLAN/LANDSCAPING PLAN FOR MATERIALS, AND STRUCTURAL PLANS FOR STRUCTURAL DESIGN OF WALL.
4. STEPPED FINISHED FLOOR ELEVATION. SEE STRUCTURAL PLANS FOR FOUNDATION DESIGN.
5. RETAINING STEM WALL WITH FINISHED FLOOR AND GROUND ELEVATIONS SHOWN. SEE STRUCTURAL PLANS FOR STEM WALL DESIGN.
6. ADA PARKING. 1.5% PREFERRED, 2.0% MAXIMUM SLOPE IN ANY DIRECTION. SEE PAVING PLANS FOR DETAILS.
7. CURB RAMP PER DETAILS ON PAVING PLANS.
8. ADA RAMP AT 7.5% PREFERRED, 8.0% MAXIMUM SLOPE. SEE ARCHITECTURAL SITE PLAN FOR DETAILS.
9. STEPS. SEE ARCHITECTURAL SITE PLAN FOR DETAILS.
10. STORM INLET INSTALLED AT RIM ELEVATION SHOWN. STORM DRAIN DESIGN AND DETAILS ON SHEET CG-502.
11. TRENCH DRAINS INSTALLED AT RIM ELEVATIONS SHOWN. STORM DRAIN DESIGN AND DETAILS ON SHEET CG-502.
12. FRENCH DRAIN INSTALLED PER DETAIL ON SHEET CG-501.
13. 20 LF 6" PVC OR ADS N-12 PIPE @ 1.0% MINIMUM SLOPE.
14. CMU WALL OPENING PER DETAIL ON SHEET CG-501 TO ALLOW WATER TO PASS THROUGH.
15. COLLECTION POND FOR OFFSITE BASIN.
16. 2' WIDE CURB OPENING PER DETAIL ON SHEET CG-501.
17. 2' SIDEWALK CULVERT PER DETAIL ON SHEET CG-501.
18. AMAFCA MAINTENANCE ACCESS. SEE PAVING PLAN FOR DETAILS.
19. 4" HIGH ROLLED CURB.
20. 5' WIDE DIRT TRAIL. THIS PATH IS NOT ADA.
21. GARBAGE COMPACTORS. SEE ARCHITECTURAL SITE PLAN FOR DETAILS.
22. ROCK ARMOUR 2:1 SLOPE

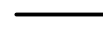

SCALE 1"=20'

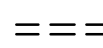

	EXISTING CONTOUR
	EXISTING SPOT ELEVATION
	PROPOSED 1.0' CONTOUR
	PROPOSED 0.5' CONTOUR
	PROPOSED SPOT ELEVATION
	FLOW DIRECTION
	FINISH FLOOR ELEVATION
	EXISTING STORM DRAIN / MANHOLE
	PROPOSED STORM DRAIN / INLET

**ALLASO HIGH DESERT**  
 SWC TENNYSON STREET AND SAN ANTONIO DR.  
 Albuquerque, New Mexico



WorldHQ@ORBArch.com



Contractor must verify all dimensions at project before proceeding with this work.  
 Do not reproduce these drawings and specifications without the expressed written permission of the architect. The drawings and specifications are instruments of service and shall remain the property of the architect whether the project for which they are made is executed or not. These drawings and specifications shall not be used by anyone on any other project, for additions to this project, or for completion of this project by others except by the expressed written permission of the architect.  
 © ORB Architecture, LLC 2015

**REVISIONS**



**EPC SUBMITTAL**

DATE: JULY 28, 2020 ORB # 19-209

**GRADING & DRAINAGE**  
 PLAN 1 OF 4

**CG-102**

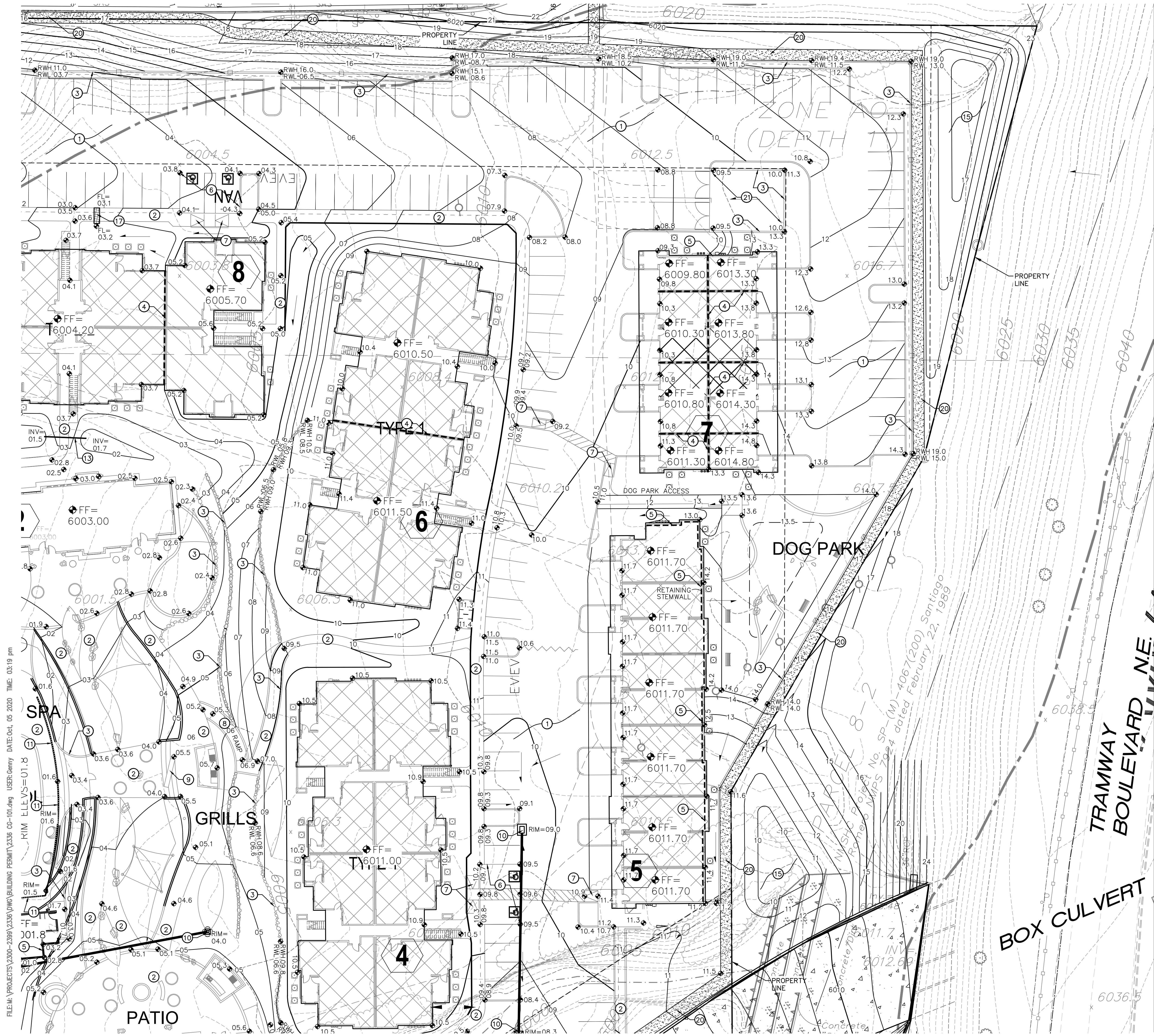



KEYED NOTES

1. PAVING TO BE INSTALLED AT GRADES SHOWN. SEE PAVING PLAN FOR PAVING SECTIONS.
2. CONCRETE SIDEWALK AND FLATWORK INSTALLED AT ELEVATIONS SHOWN. 5.0% MAXIMUM LONGITUDINAL SLOPE, 2.0% MAXIMUM CROSS-SLOPE. SEE ARCHITECTURAL SITE PLAN FOR DETAILS.
3. INSTALL RETAINING WALL WITH GROUND ELEVATIONS SHOWN IN THIS PLAN AT TOP AND BOTTOM OF RETAINING. SEE ARCHITECTURAL SITE PLAN/LANSCAPING PLAN FOR MATERIALS, AND STRUCTURAL PLANS FOR STRUCTURAL DESIGN OF WALL.
4. STEPPED FINISHED FLOOR ELEVATION. SEE STRUCTURAL PLANS FOR FOUNDATION DESIGN.
5. RETAINING STEM WALL WITH FINISHED FLOOR AND GROUND ELEVATIONS SHOWN. SEE STRUCTURAL PLANS FOR STEM WALL DESIGN.
6. ADA PARKING. 1.5% PREFERRED, 2.0% MAXIMUM SLOPE IN ANY DIRECTION. SEE PAVING PLANS FOR DETAILS.
7. CURB RAMP PER DETAILS ON PAVING PLANS.
8. ADA RAMP AT 7.5% PREFERRED, 8.0% MAXIMUM SLOPE. SEE ARCHITECTURAL SITE PLAN FOR DETAILS.
9. STEPS. SEE ARCHITECTURAL SITE PLAN FOR DETAILS.
10. STORM INLET INSTALLED AT RIM ELEVATION SHOWN. STORM DRAIN DESIGN AND DETAILS ON SHEET CG-502.
11. TRENCH DRAINS INSTALLED AT RIM ELEVATIONS SHOWN. STORM DRAIN DESIGN AND DETAILS ON SHEET CG-502.
12. FRENCH DRAIN INSTALLED PER DETAIL ON SHEET CG-501.
13. 20 LF 6" PVC OR ADS N-12 PIPE @ 1.0% MINIMUM SLOPE.
14. CMU WALL OPENING PER DETAIL ON SHEET CG-501 TO ALLOW WATER TO PASS THROUGH.
15. COLLECTION POND FOR OFFSITE BASIN.
16. 2' WIDE CURB OPENING PER DETAIL ON SHEET CG-501.
17. 2' SIDEWALK CULVERT PER DETAIL ON SHEET CG-501.
18. AMAFCA MAINTENANCE ACCESS. SEE PAVING PLAN FOR DETAILS.
19. 4" HIGH ROLLED CURB.
20. 5' WIDE DIRT TRAIL. THIS PATH IS NOT ADA.
21. GARBAGE COMPACTORS. SEE ARCHITECTURAL SITE PLAN FOR DETAILS.
22. ROCK ARMOUR 2:1 SLOPE

Contractor must verify all dimensions at project before proceeding with this work.

Do not reproduce these drawings and specifications without the expressed written permission of the architect. The drawings and specifications are instruments of service and shall remain the property of the architect whether the project for which they are made is executed or not. These drawings and specifications shall not be used by anyone on any other project, for additions to this project, or for completion of this project by others except by the expressed written permission of the architect.

© ORB Architecture, LLC 2015

**REVISIONS**

△	
△	
△	
△	
△	
△	
△	

EPC SUBMITTAL

DATE: JULY 28, 2020 ORB # 19-209

GRADING & DRAINAGE  
PLAN 2 OF 4

**CG-103**

---	6030	EXISTING CONTOUR
---	6029.4	EXISTING SPOT ELEVATION
---	65	PROPOSED 1.0' CONTOUR
---	65.5	PROPOSED 0.5' CONTOUR
◆	65.4	PROPOSED SPOT ELEVATION
→		FLOW DIRECTION
FF =	4966.00	FINISH FLOOR ELEVATION
---		EXISTING STORM DRAIN / MANHOLE
---		PROPOSED STORM DRAIN / INLET

**ALLASO HIGH DESERT**  
SWC TENNYSON STREET AND SAN ANTONIO DR.  
Albuquerque, New Mexico



FILE: \\PROJECTS\2300-2399\2336\DWG\BUILDING PERMIT\2336 CG-101.dwg USER: Genny DATE: 04/05/2020 TIME: 03:19 pm

MUSCO PARKWAY No. SP (M) 4067(200) Santiago  
Concrete Note: Retard. Agent, No SP (M) 4067(200) dated February 22, 1989



**KEYED NOTES**

1. PAVING TO BE INSTALLED AT GRADES SHOWN. SEE PAVING PLAN FOR PAVING SECTIONS.
2. CONCRETE SIDEWALK AND FLATWORK INSTALLED AT ELEVATIONS SHOWN. 5.0% MAXIMUM LONGITUDINAL SLOPE, 2.0% MAXIMUM CROSS-SLOPE. SEE ARCHITECTURAL SITE PLAN FOR DETAILS.
3. INSTALL RETAINING WALL WITH GROUND ELEVATIONS SHOWN IN THIS PLAN AT TOP AND BOTTOM OF RETAINING. SEE ARCHITECTURAL SITE PLAN/LANDSCAPING PLAN FOR MATERIALS, AND STRUCTURAL PLANS FOR STRUCTURAL DESIGN OF WALL.
4. STEPPED FINISHED FLOOR ELEVATION. SEE STRUCTURAL PLANS FOR FOUNDATION DESIGN.
5. RETAINING STEM WALL WITH FINISHED FLOOR AND GROUND ELEVATIONS SHOWN. SEE STRUCTURAL PLANS FOR STEM WALL DESIGN.
6. ADA PARKING. 1.5% PREFERRED, 2.0% MAXIMUM SLOPE IN ANY DIRECTION. SEE PAVING PLANS FOR DETAILS.
7. CURB RAMP PER DETAILS ON PAVING PLANS.
8. ADA RAMP AT 7.5% PREFERRED, 8.0% MAXIMUM SLOPE. SEE ARCHITECTURAL SITE PLAN FOR DETAILS.
9. STEPS. SEE ARCHITECTURAL SITE PLAN FOR DETAILS.
10. STORM INLET INSTALLED AT RIM ELEVATION SHOWN. STORM DRAIN DESIGN AND DETAILS ON SHEET CG-502.
11. TRENCH DRAINS INSTALLED AT RIM ELEVATIONS SHOWN. STORM DRAIN DESIGN AND DETAILS ON SHEET CG-502.
12. FRENCH DRAIN INSTALLED PER DETAIL ON SHEET CG-501.
13. 20 LF 6" PVC OR ADS N-12 PIPE @ 1.0% MINIMUM SLOPE.
14. CMU WALL OPENING PER DETAIL ON SHEET CG-501 TO ALLOW WATER TO PASS THROUGH.
15. COLLECTION POND FOR OFFSITE BASIN.
16. 2' WIDE CURB OPENING PER DETAIL ON SHEET CG-501.
17. 2' SIDEWALK CULVERT PER DETAIL ON SHEET CG-501.
18. AMAFCA MAINTENANCE ACCESS. SEE PAVING PLAN FOR DETAILS.
19. 4" HIGH ROLLED CURB.
20. 5' WIDE DIRT TRAIL. THIS PATH IS NOT ADA.
21. GARBAGE COMPACTORS. SEE ARCHITECTURAL SITE PLAN FOR DETAILS.
22. ROCK ARMOUR 2:1 SLOPE

**ALLASO HIGH DESERT**  
 SWC TENNYSON STREET AND SAN ANTONIO DR.  
 Albuquerque, New Mexico



WorldHQ@ORBArch.com



Contractor must verify all dimensions at project before proceeding with this work.  
 Do not reproduce these drawings and specifications without the expressed written permission of the architect. The drawings and specifications are instruments of service and shall remain the property of the architect whether the project for which they are made is executed or not. These drawings and specifications shall not be used by anyone on any other project, for additions to this project, or for completion of this project by others except by the expressed written permission of the architect.  
 © ORB Architecture, LLC 2015

**REVISIONS**

△	
△	
△	
△	
△	

**EPC SUBMITTAL**

DATE: JULY 28, 2020 ORB # 19-209

**GRADING & DRAINAGE PLAN 3 OF 4**

**CG-104**

0 10 20 40 60  
 SCALE 1"=20'

- - - - - 60.30 EXISTING CONTOUR
- 6029.4 EXISTING SPOT ELEVATION
- 65 — PROPOSED 1.0' CONTOUR
- - - - - 65.5 - - - PROPOSED 0.5' CONTOUR
- ◆ 65.4 PROPOSED SPOT ELEVATION
- FLOW DIRECTION
- FF = 4966.00 FINISH FLOOR ELEVATION
- — — — — ○ — — — — — EXISTING STORM DRAIN / MANHOLE
- — — — — ● — — — — — PROPOSED STORM DRAIN / INLET

FILE: \\H:\PROJECTS\2300-2399\2336\DWG\BUILDING PERMIT\2336 CG-101.dwg USER: Genny DATE: Oct, 05 2020 TIME: 03:20 pm



### KEYED NOTES

- PAVING TO BE INSTALLED AT GRADES SHOWN. SEE PAVING PLAN FOR PAVING SECTIONS.
- CONCRETE SIDEWALK AND FLATWORK INSTALLED AT ELEVATIONS SHOWN. 5.0% MAXIMUM LONGITUDINAL SLOPE, 2.0% MAXIMUM CROSS-SLOPE. SEE ARCHITECTURAL SITE PLAN FOR DETAILS.
- INSTALL RETAINING WALL WITH GROUND ELEVATIONS SHOWN IN THIS PLAN AT TOP AND BOTTOM OF RETAINING. SEE ARCHITECTURAL SITE PLAN/LANDSCAPING PLAN FOR MATERIALS, AND STRUCTURAL PLANS FOR STRUCTURAL DESIGN OF WALL.
- STEPPED FINISHED FLOOR ELEVATION. SEE STRUCTURAL PLANS FOR FOUNDATION DESIGN.
- RETAINING STEM WALL WITH FINISHED FLOOR AND GROUND ELEVATIONS SHOWN. SEE STRUCTURAL PLANS FOR STEM WALL DESIGN.
- ADA PARKING. 1.5% PREFERRED, 2.0% MAXIMUM SLOPE IN ANY DIRECTION. SEE PAVING PLANS FOR DETAILS.
- CURB RAMP PER DETAILS ON PAVING PLANS.
- ADA RAMP AT 7.5% PREFERRED, 8.0% MAXIMUM SLOPE. SEE ARCHITECTURAL SITE PLAN FOR DETAILS.
- STEPS. SEE ARCHITECTURAL SITE PLAN FOR DETAILS.
- STORM INLET INSTALLED AT RIM ELEVATION SHOWN. STORM DRAIN DESIGN AND DETAILS ON SHEET CG-502.
- TRENCH DRAINS INSTALLED AT RIM ELEVATIONS SHOWN. STORM DRAIN DESIGN AND DETAILS ON SHEET CG-502.
- FRENCH DRAIN INSTALLED PER DETAIL ON SHEET CG-501.
- 20 LF 6" PVC OR ADS N-12 PIPE @ 1.0% MINIMUM SLOPE.
- CMU WALL OPENING PER DETAIL ON SHEET CG-501 TO ALLOW WATER TO PASS THROUGH.
- COLLECTION POND FOR OFFSITE BASIN.
- 2' WIDE CURB OPENING PER DETAIL ON SHEET CG-501.
- 2' SIDEWALK CULVERT PER DETAIL ON SHEET CG-501.
- AMAFCA MAINTENANCE ACCESS. SEE PAVING PLAN FOR DETAILS.
- 4" HIGH ROLLED CURB.
- 5' WIDE DIRT TRAIL. THIS PATH IS NOT ADA.
- GARBAGE COMPACTORS. SEE ARCHITECTURAL SITE PLAN FOR DETAILS.
- ROCK ARMOUR 2:1 SLOPE

SCALE 1"=20'

---	EXISTING CONTOUR
●	EXISTING SPOT ELEVATION
---	PROPOSED 1.0' CONTOUR
---	PROPOSED 0.5' CONTOUR
◆	PROPOSED SPOT ELEVATION
→	FLOW DIRECTION
FF = 4966.00	FINISH FLOOR ELEVATION
---	EXISTING STORM DRAIN / MANHOLE
---	PROPOSED STORM DRAIN / INLET

# ALLASO HIGH DESERT

SWC TENNYNISON STREET AND SAN ANTONIO DR. Albuquerque, New Mexico

Office of Rich Barber Architecture, LLC

# ORB

WorldHQ@ORBArch.com

---

TITAN DEVELOPMENT

---

Contractor must verify all dimensions at project before proceeding with this work.

Do not reproduce these drawings and specifications without the expressed written permission of the architect. The drawings and specifications are instruments of service and shall remain the property of the architect whether the project for which they are made is executed or not. These drawings and specifications shall not be used by anyone on any other project, for additions to this project, or for completion of this project by others except by the expressed written permission of the architect.

© ORB Architecture, LLC 2015

### REVISIONS

△	
△	
△	
△	
△	

EPC SUBMITTAL

DATE: JULY 28, 2020 ORB # 19-209

GRADING & DRAINAGE PLAN 4 OF 4

CG-105

FILE: \\PROJECTS\2300-2399\2336\DWG\BUILDING PERMIT\2336 CG-101.dwg  
 USER: Genny DATE: Oct, 05 2020 TIME: 03:20 pm

FILE: H:\PROJECTS\2300-2399\2336\DWG\BUILDING PERMIT\2336 CG-101.dwg USER: Genny DATE: Oct, 05 2020 TIME: 03:20 pm

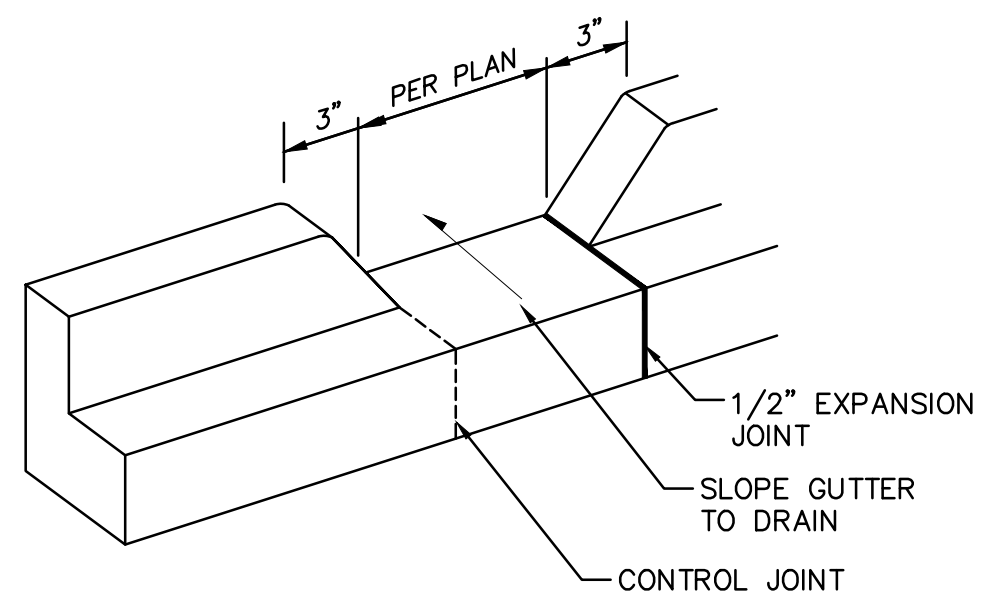

**CURB OPENING**

SCALE: N.T.S.

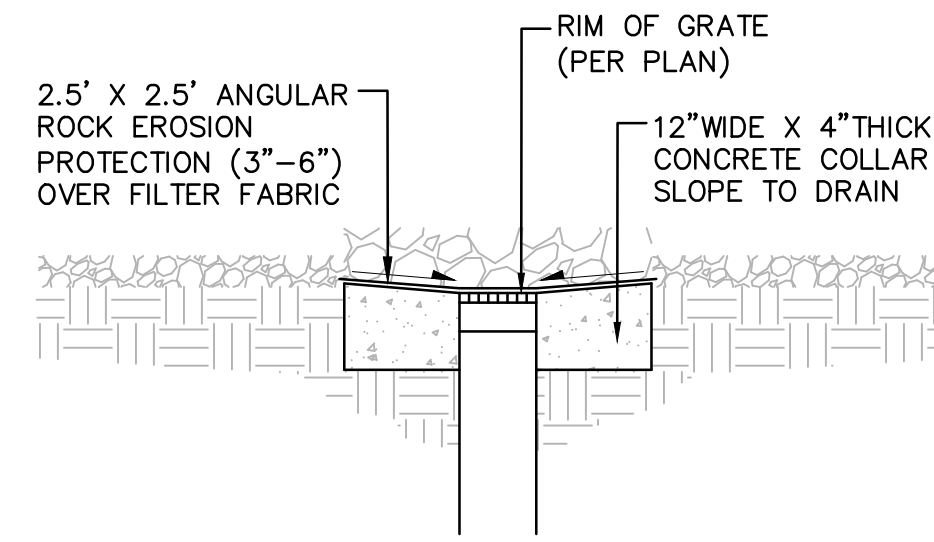

**LANDSCAPE AREA DRAIN**

SCALE: N.T.S.

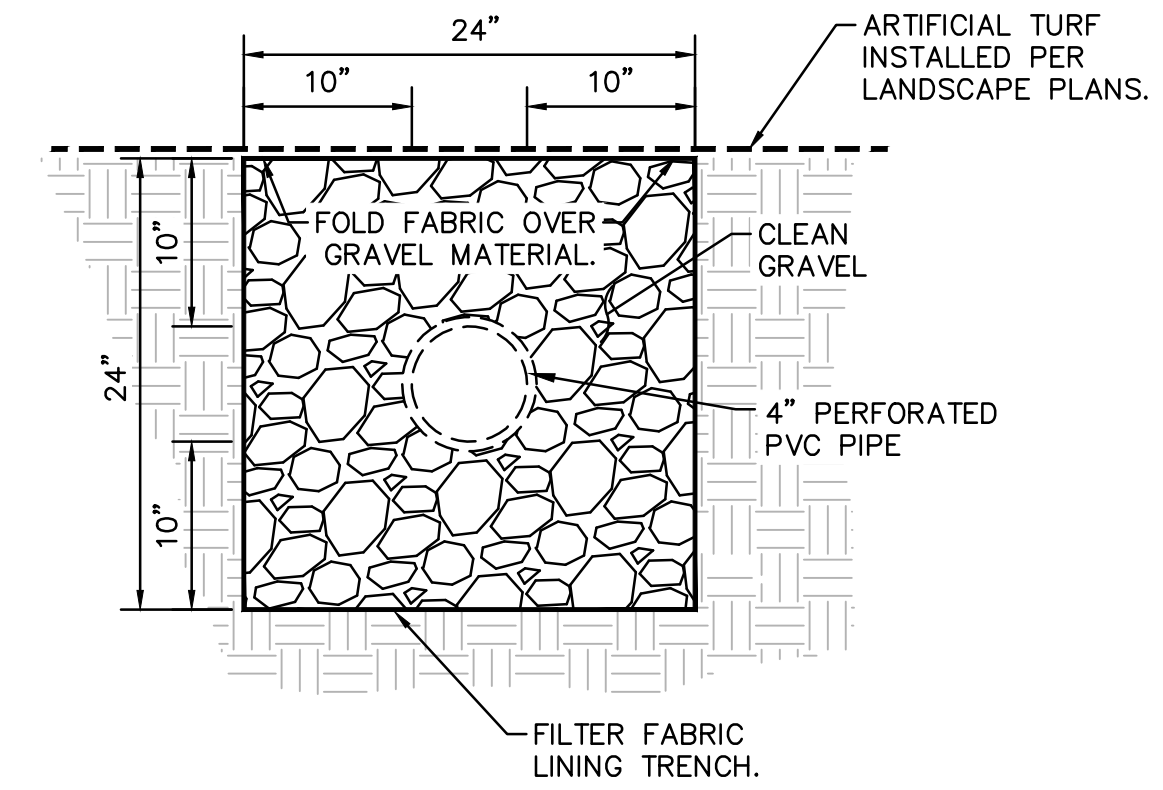

**FRENCH DRAIN**

SCALE: N.T.S.

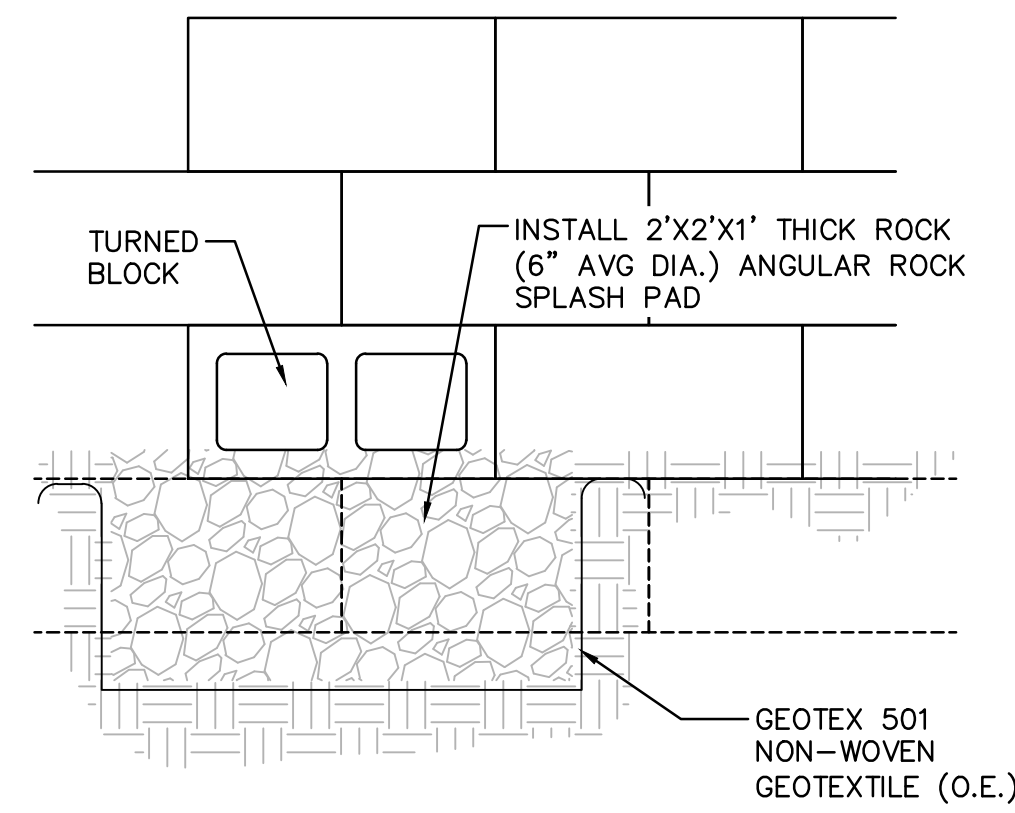

**CMU WALL OPENING(S)**

SCALE: N.T.S.

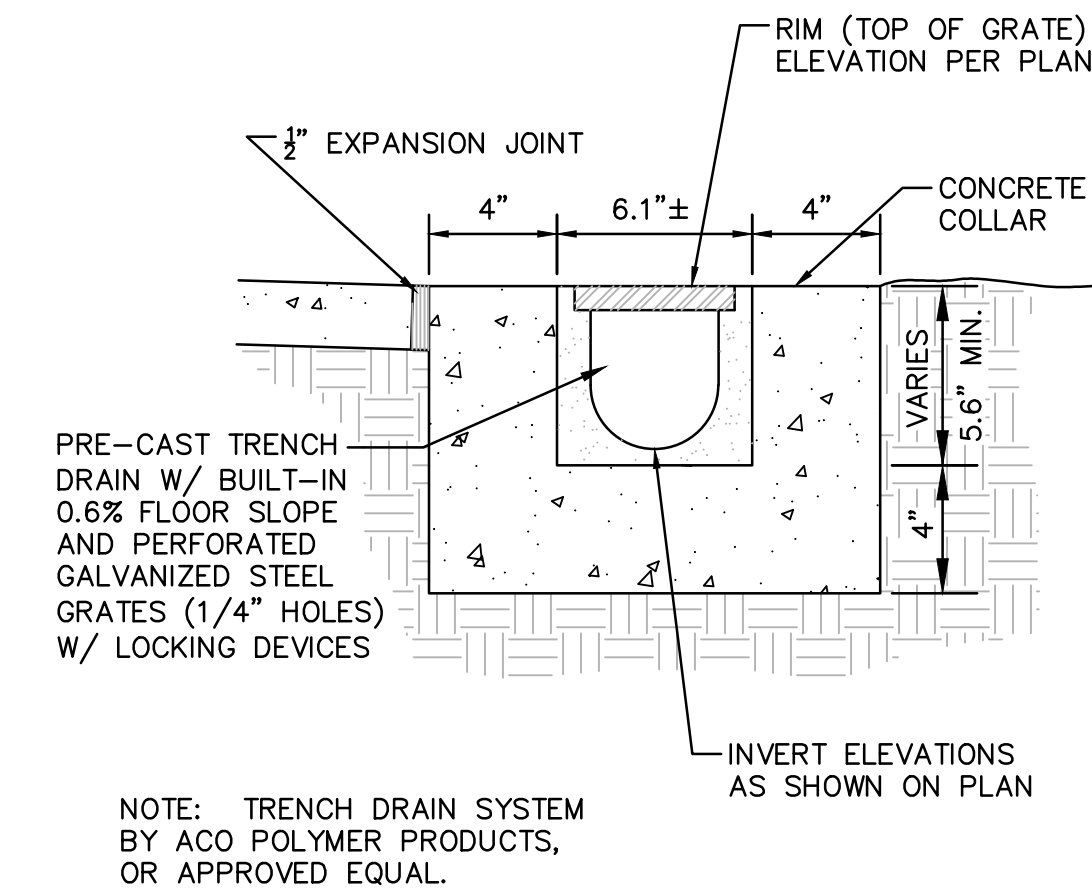

**TRENCH DRAIN**

SCALE: N.T.S.

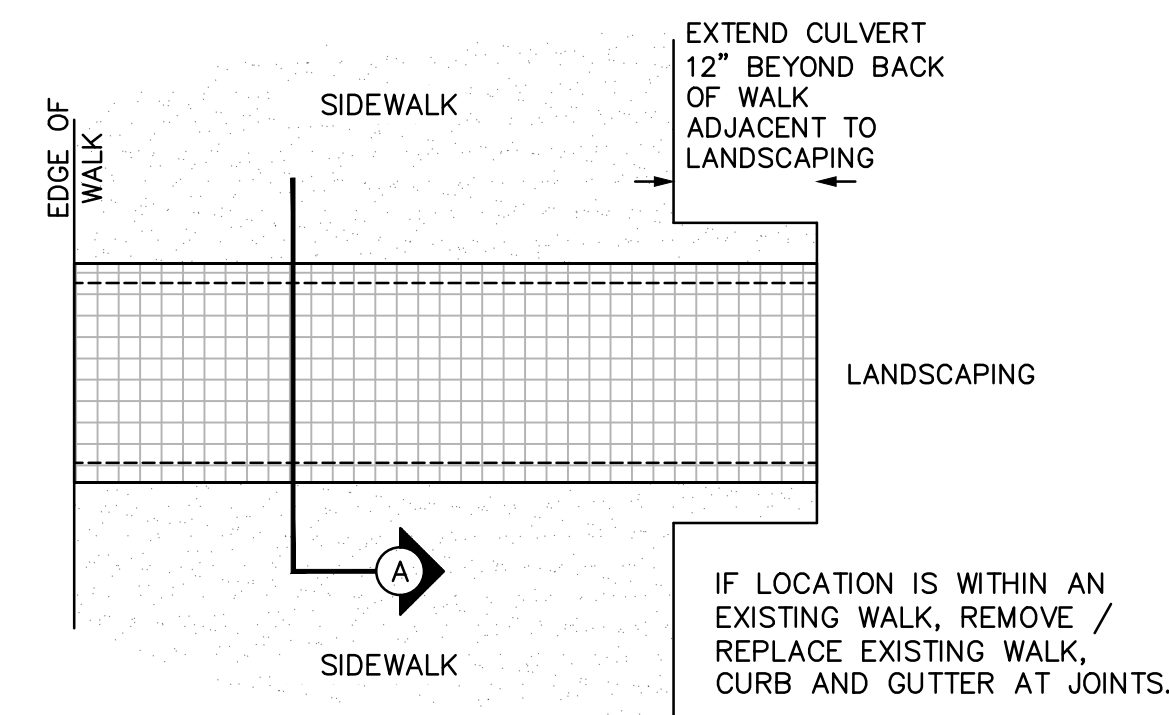

**COVERED SIDEWALK CULVERT**

CONSTRUCT PER COA STD. DWG 2236 WITH MODIFICATIONS PER THIS DETAIL

SCALE: N.T.S.

WELD 1/8" THICK, 5/8" MIN. DIAMETER OVER ALL SCREWS. COMPLETELY COVER SCREW HEADS. GRIND EDGES SMOOTH.

FOR SECURING PLATE USE 1"X5" S.S. ROD ANCHOR, "RED HEAD MULTI-SET II SRM-38 ANCHOR" OR APPROVED EQUAL. INSTALL PER MANUFACTURER'S INSTRUCTIONS AT MAX. 24" O.C., A MINIMUM OF 2 PER SIDE AND ONE WITHIN 6" OF EACH END.

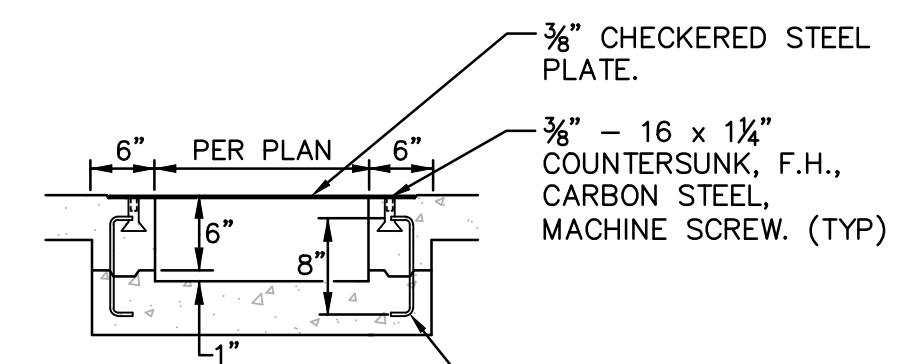

USE NO. 3 DEFORMED BAR DOWELS. SPACED DOWELS AT 18" O.C. MAXIMUM. 1-1/2" MINIMUM FROM FACE OF CONCRETE

SECTION A

Contractor must verify all dimensions of project before proceeding with this work.  
Do not reproduce these drawings and specifications without the expressed written permission of the Architect. The drawings and specifications are instruments of service and shall remain the property of the Architect whether the project for which they are made is executed or not. These drawings and specifications shall not be used by anyone on any other project, for additions to this project, or for completion of this project by others except by the expressed written permission of the Architect.  
© ORB Architecture, LLC 2015

**REVISIONS**

EPC SUBMITTAL

DATE: JULY 28, 2020 ORB # 19-209

GRADING DETAILS

CG-501

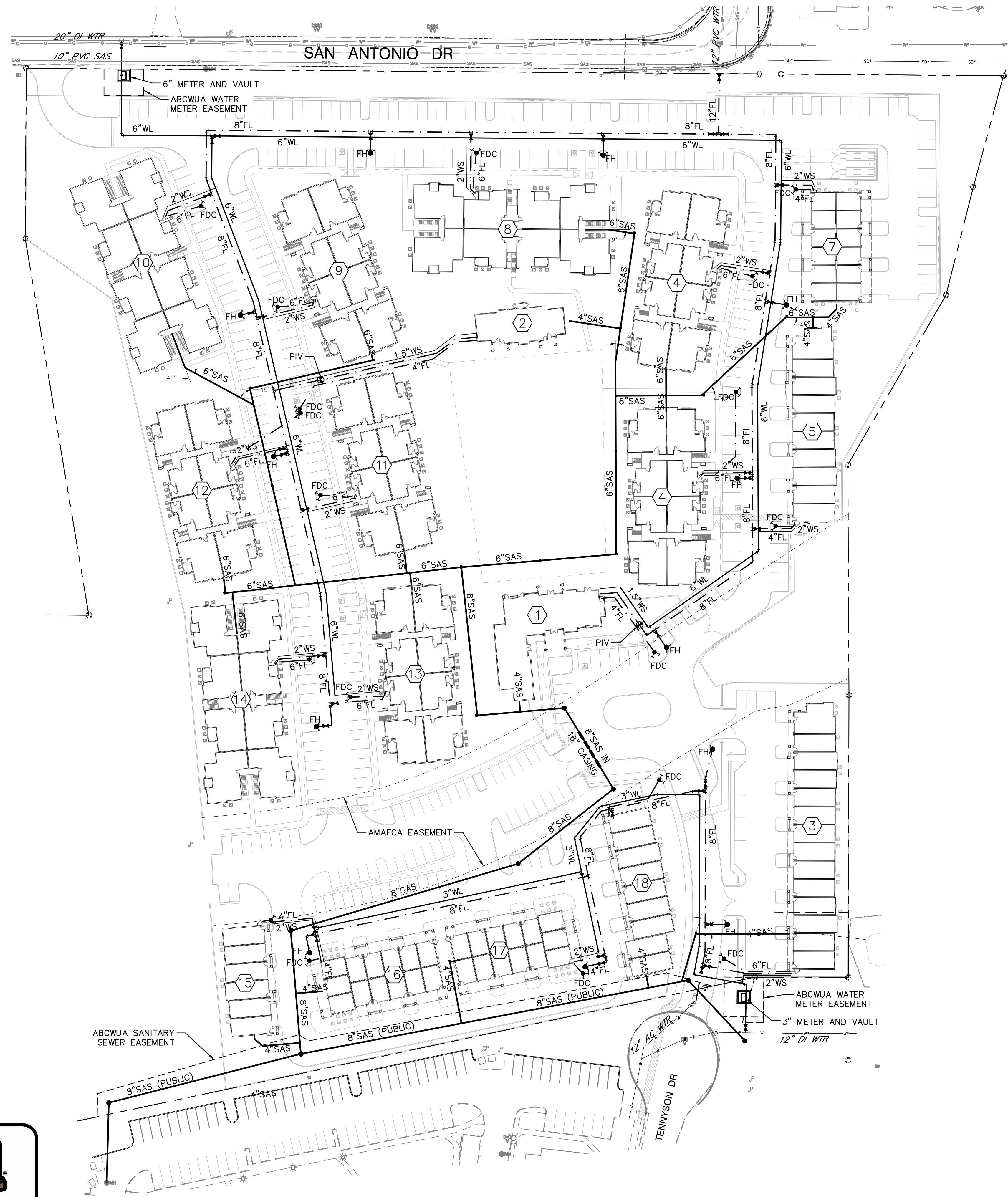

TRAMWAY BLVD

SAN ANTONIO DR

TENNYSON DR

FILE: M:\PROJECTS\2300-2399\2336\DWG\CONCEPTUAL\2236 CU-101-CONCEPTUAL.dwg USER: Geny DATE: Jul 29 2020 TIME: 05:21 pm



# ALLASO HIGH DESERT

SWC TENNYSON STREET AND SAN ANTONIO DR.  
Albuquerque, New Mexico



Contractor must verify all dimensions at project before proceeding with this work. Do not reproduce these drawings and specifications without the expressed written permission of the Architect. The drawings and specifications are instruments of service and shall remain the property of the Architect whether the project for which they are made is executed or not. These drawings and specifications shall not be used by anyone on any other project, for additions to this project or for completion of this project by others except by the expressed written permission of the Architect.  
© ORB Architecture, LLC 2015

## REVISIONS



## EPC SUBMITTAL

DATE: JULY 28, 2020 ORB # 19-209

# CONCEPTUAL SITE UTILITY PLAN

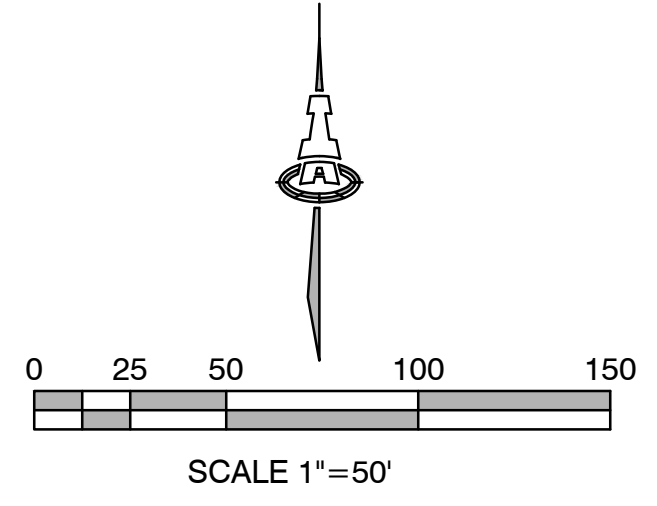
## CU-101

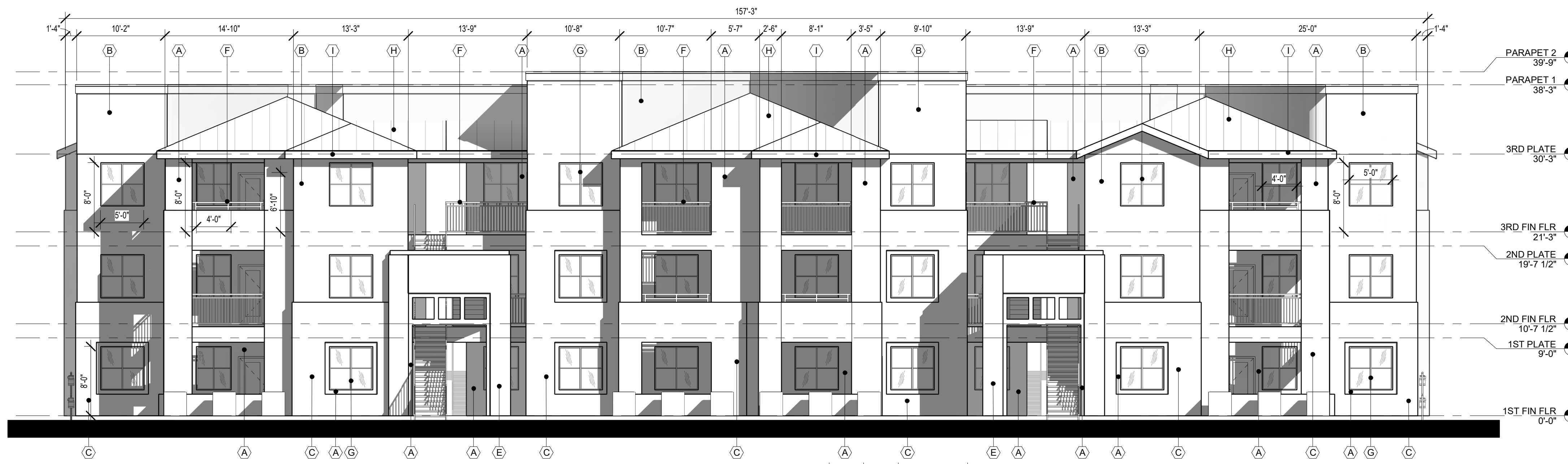



1 BLDG TYPE 1 - FRONT ELEVATION

MATERIAL AND COLOR KEY

A	STUCCO LIGHT YELLOW LRV 50
B	STUCCO LIGHT BROWN LRV 42
C	STUCCO DARK BROWN LRV 27
D	GARAGE DOOR PAINTED DARK BROWN LRV 27
E	STUCCO LIGHT RED LRV 20
F	METAL RAILINGS COLOR WHITE
G	VINYL WINDOWS COLOR WHITE
H	GREY METAL ROOF LRV TO BE BETWEEN 20 & 50
I	METAL FASCIA COLOR WHITE

**ALLASO  
HIGH DESERT**  
SWC TENNYSON STREET AND SAN ANTONIO DR.  
ALBUQUERQUE, NEW MEXICO

Office of Rich Barber  
**ORB**  
Architecture  
WorldHQ@ORBArch.com

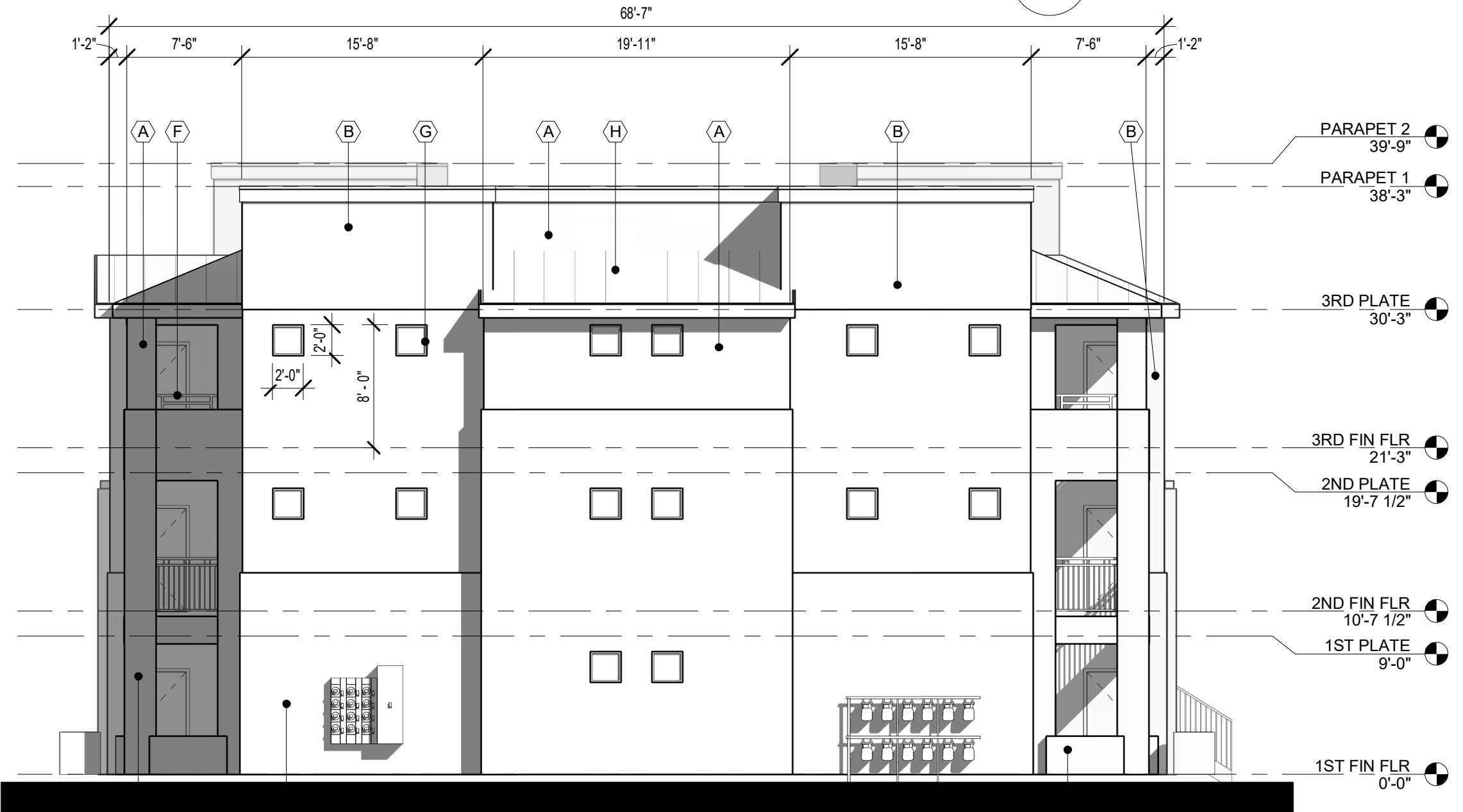

3 BLDG TYPE 1 - LEFT ELEVATION

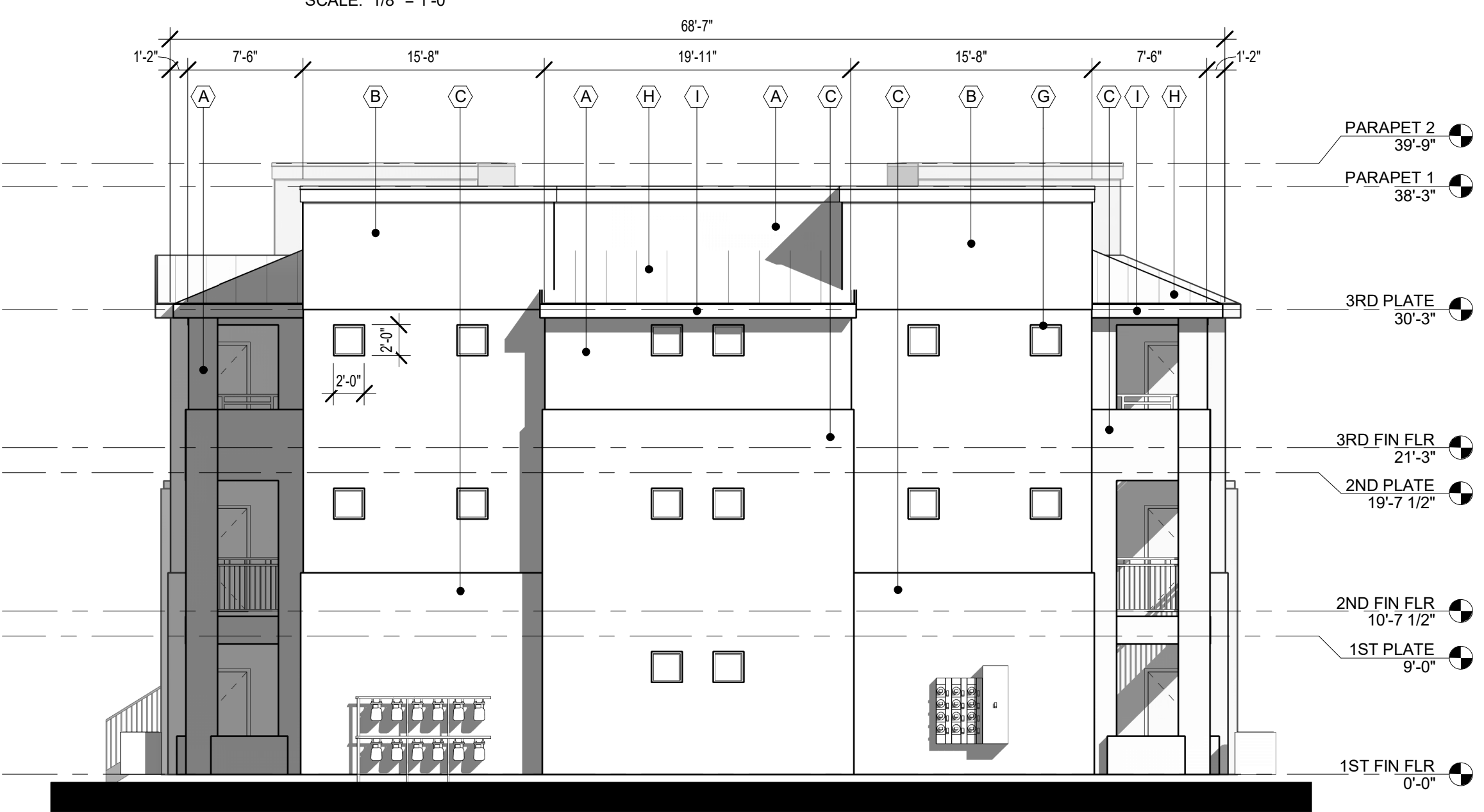

2 BLDG TYPE 1 - RIGHT ELEVATION



4 BLDG TYPE 1 - REAR ELEVATION

DRB SUBMITTAL  
DATE: OCTOBER 5, 2020 ORB #: 19-209

**A3.13**  
BUILDING TYPE 1 - EXTERIOR  
ELEVATIONS

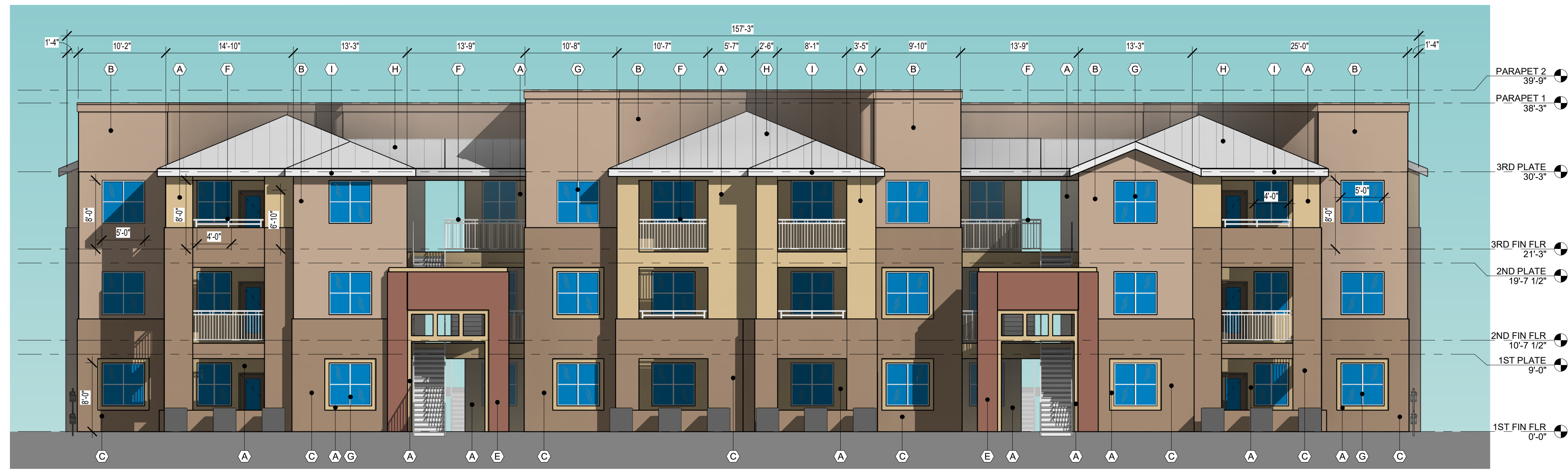

1 BLDG TYPE 1 - FRONT ELEVATION  
SCALE: 1/8" = 1'-0"

**MATERIAL AND COLOR KEY**

A	STUCCO LIGHT YELLOW LRV 50
B	STUCCO LIGHT BROWN LRV 42
C	STUCCO DARK BROWN LRV 27
D	GARAGE DOOR PAINTED DARK BROWN LRV 27
E	STUCCO LIGHT RED LRV 20
F	METAL RAILINGS COLOR WHITE
G	VINYL WINDOWS COLOR WHITE
H	GREY METAL ROOF LRV TO BE BETWEEN 20 & 50
I	METAL FASCIA COLOR WHITE

**ALLASO HIGH DESERT**  
SWC TENNYSON STREET AND SAN ANTONIO DR.  
ALBUQUERQUE, NEW MEXICO

Office of Rich Barber  
**ORB** Architecture  
WorldHQ@ORBArch.com



**TITAN** DEVELOPMENT

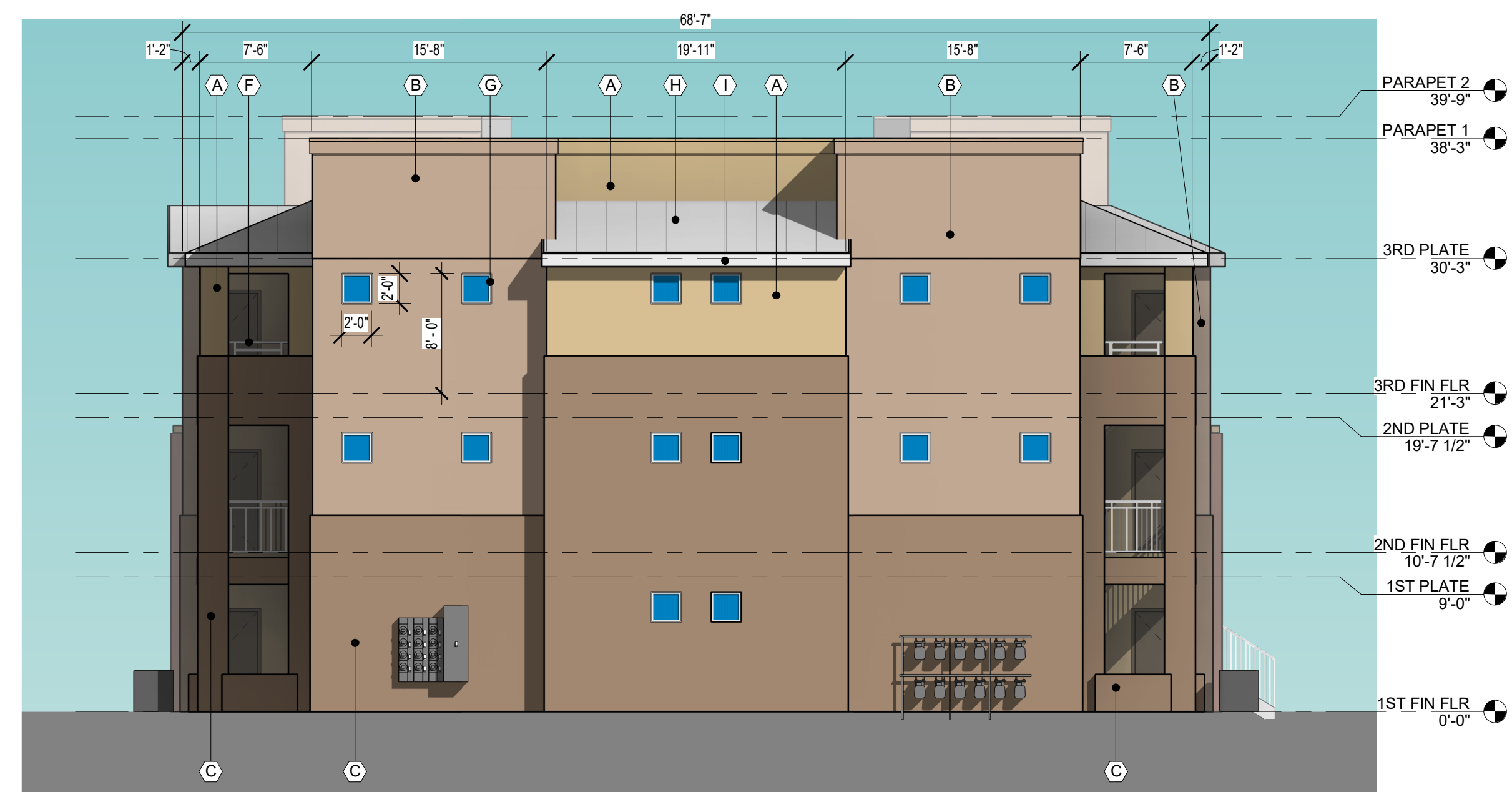

3 BLDG TYPE 1 - LEFT ELEVATION  
SCALE: 1/8" = 1'-0"

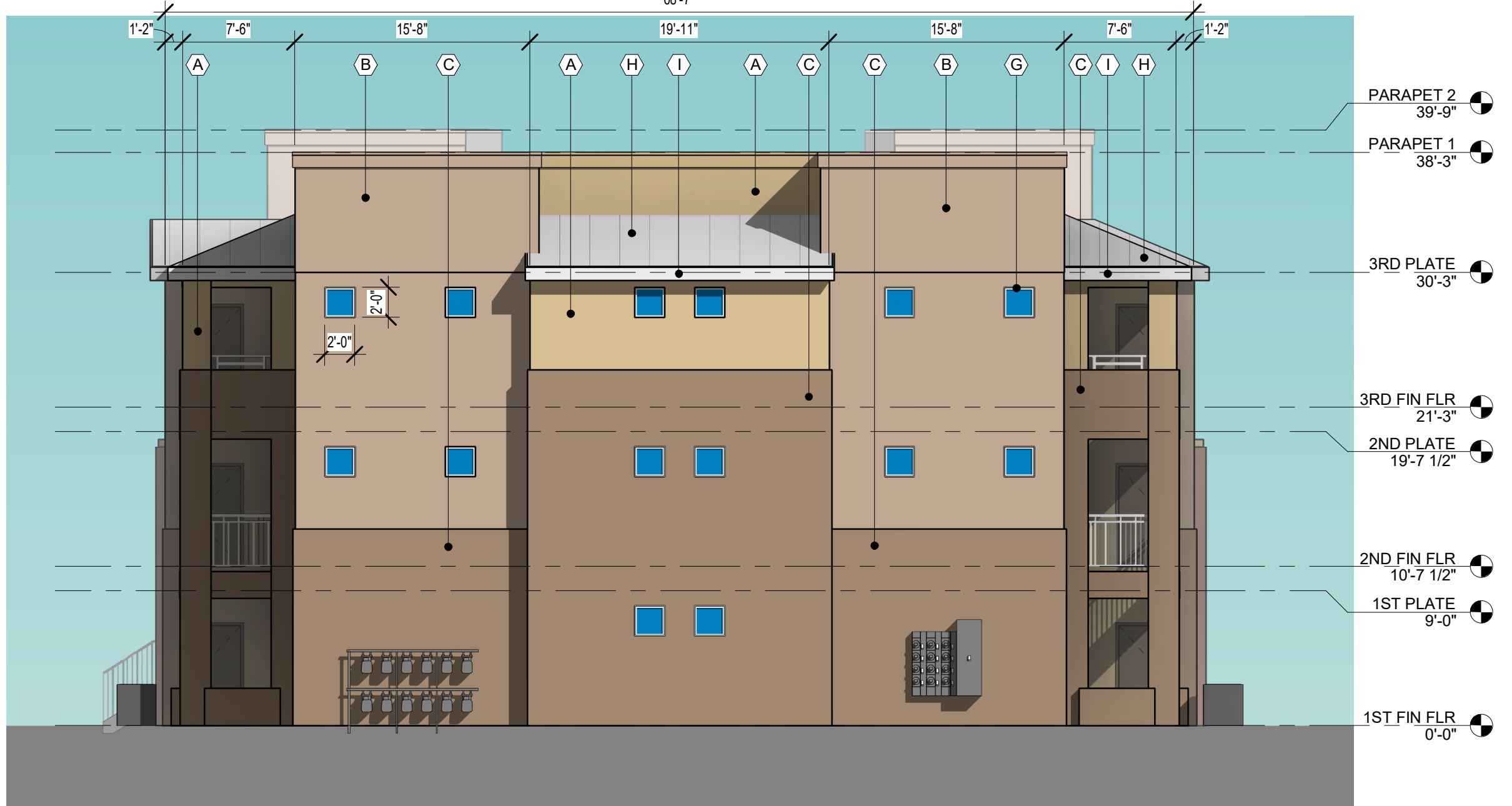

2 BLDG TYPE 1 - RIGHT ELEVATION  
SCALE: 1/8" = 1'-0"



4 BLDG TYPE 1 - REAR ELEVATION  
SCALE: 1/8" = 1'-0"

DRB SUBMITTAL  
DATE: OCTOBER 5, 2020 DRB #: 19-209

**A3.13C**  
BUILDING TYPE 1 - COLOR EXTERIOR ELEVATIONS



1 BLDG TYPE 2 - FRONT ELEVATION  
SCALE: 1/8" = 1'-0"

**MATERIAL AND COLOR KEY**

A	STUCCO LIGHT YELLOW LRV 50
B	STUCCO LIGHT BROWN LRV 42
C	STUCCO DARK BROWN LRV 27
D	GARAGE DOOR PAINTED DARK BROWN LRV 27
E	STUCCO LIGHT RED LRV 20
F	METAL RAILINGS COLOR WHITE
G	VINYL WINDOWS COLOR WHITE
H	GREY METAL ROOF LRV TO BE BETWEEN 20 & 50
I	METAL FASCIA COLOR WHITE

**ALLASO HIGH DESERT**  
SWC TENNYSON STREET AND SAN ANTONIO DR.  
ALBUQUERQUE, NEW MEXICO

Office of Rich Barber  
**ORB** Architecture  
WorldHQ@ORBArch.com



**TITAN** DEVELOPMENT



3 BLDG TYPE 2 - LEFT ELEVATION  
SCALE: 1/8" = 1'-0"

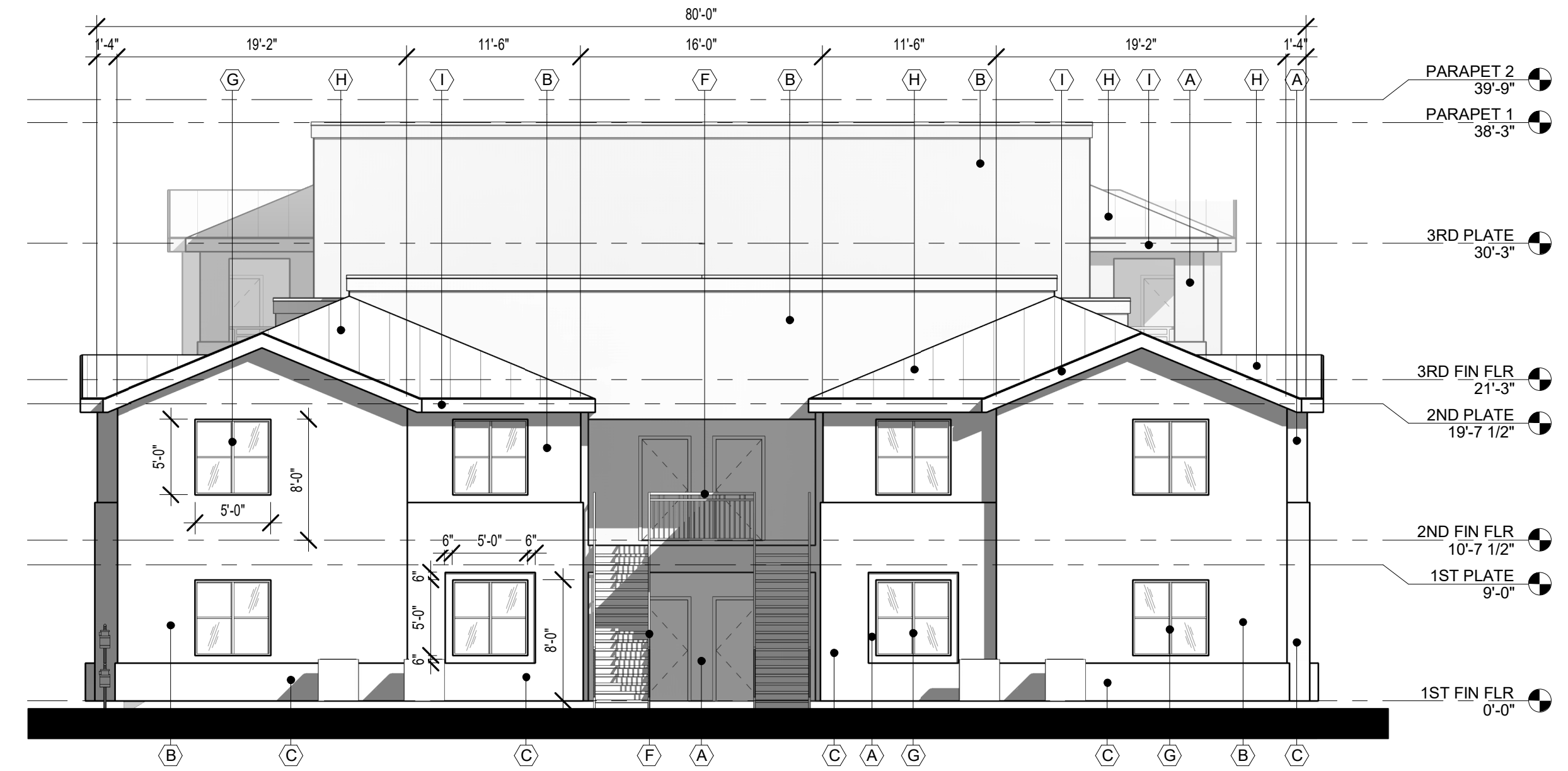

2 BLDG TYPE 2 - RIGHT ELEVATION  
SCALE: 1/8" = 1'-0"



4 BLDG TYPE 2 - REAR ELEVATION  
SCALE: 1/8" = 1'-0"

DRB SUBMITTAL  
DATE: OCTOBER 5, 2020 ORB #: 19-209

**A3.25**  
BUILDING TYPE 2 - EXTERIOR ELEVATIONS



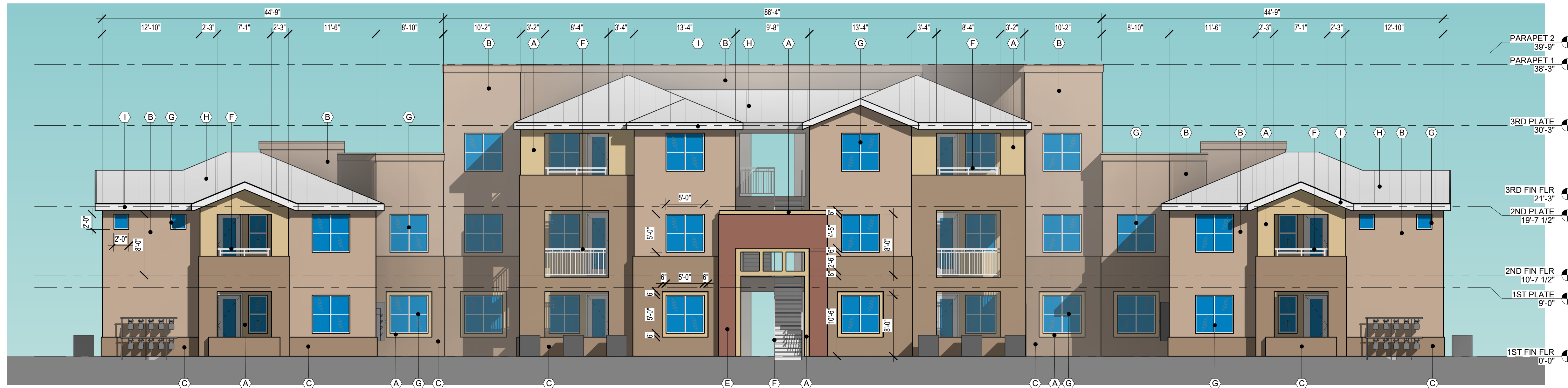

**MATERIAL AND COLOR KEY**

A	STUCCO LIGHT YELLOW LRV 50
B	STUCCO LIGHT BROWN LRV 42
C	STUCCO DARK BROWN LRV 27
D	GARAGE DOOR PAINTED DARK BROWN LRV 27
E	STUCCO LIGHT RED LRV 20
F	METAL RAILINGS COLOR WHITE
G	VINYL WINDOWS COLOR WHITE
H	GREY METAL ROOF LRV TO BE BETWEEN 20 & 50
I	METAL FASCIA COLOR WHITE

1 BLDG TYPE 2 - FRONT ELEVATION  
SCALE: 1/8" = 1'-0"

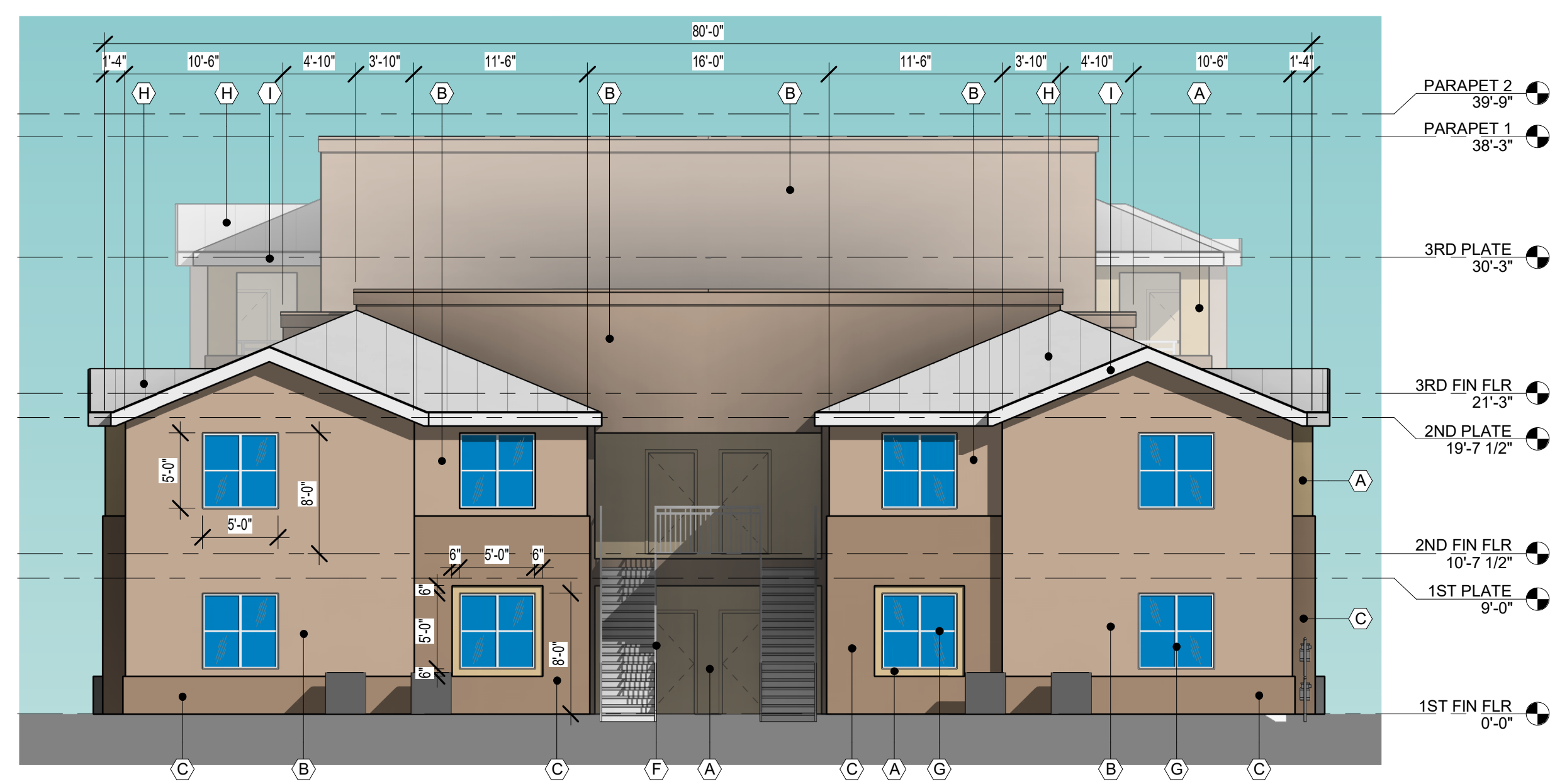

3 BLDG TYPE 2 - LEFT ELEVATION  
SCALE: 1/8" = 1'-0"

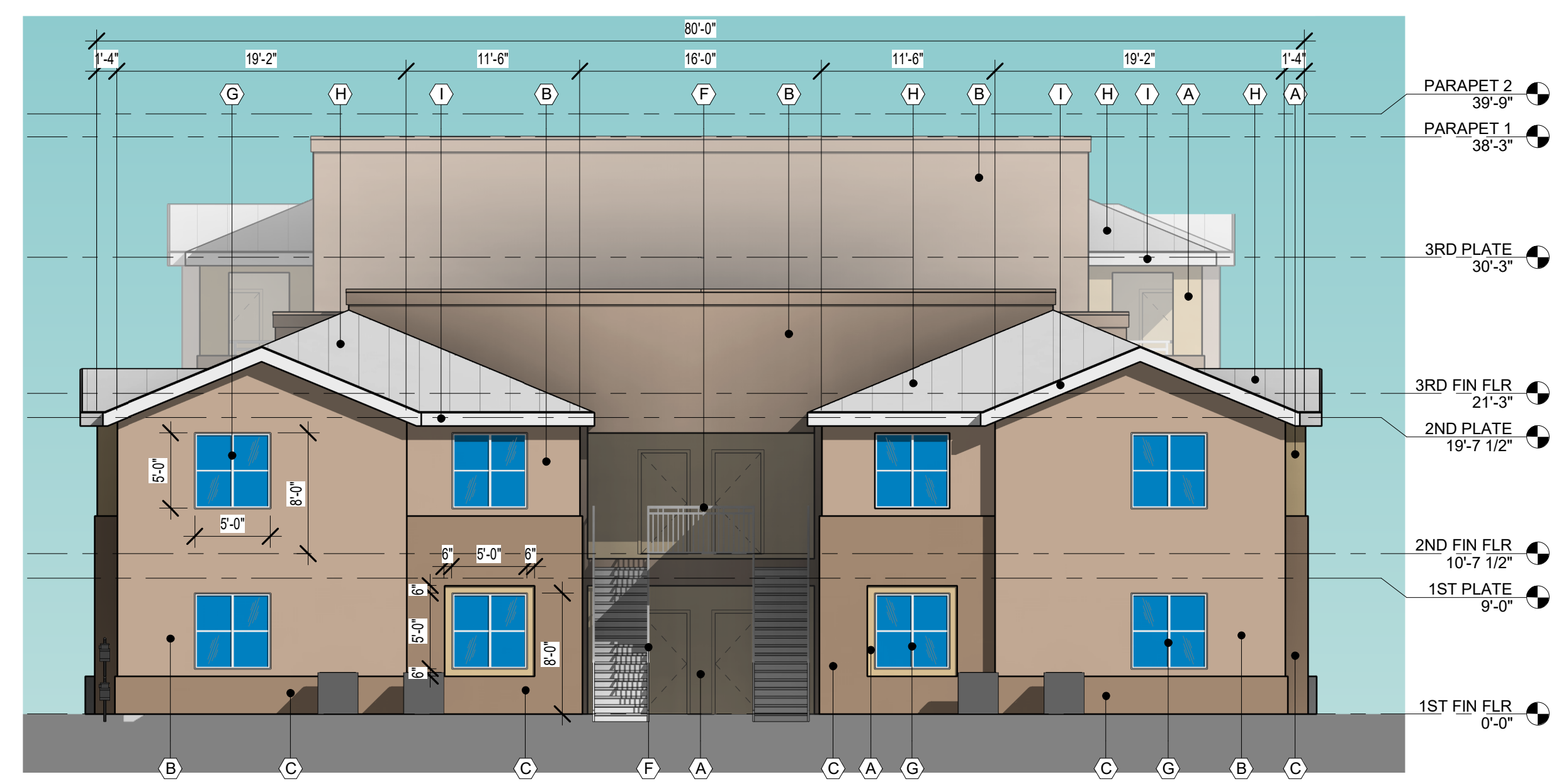

2 BLDG TYPE 2 - RIGHT ELEVATION  
SCALE: 1/8" = 1'-0"

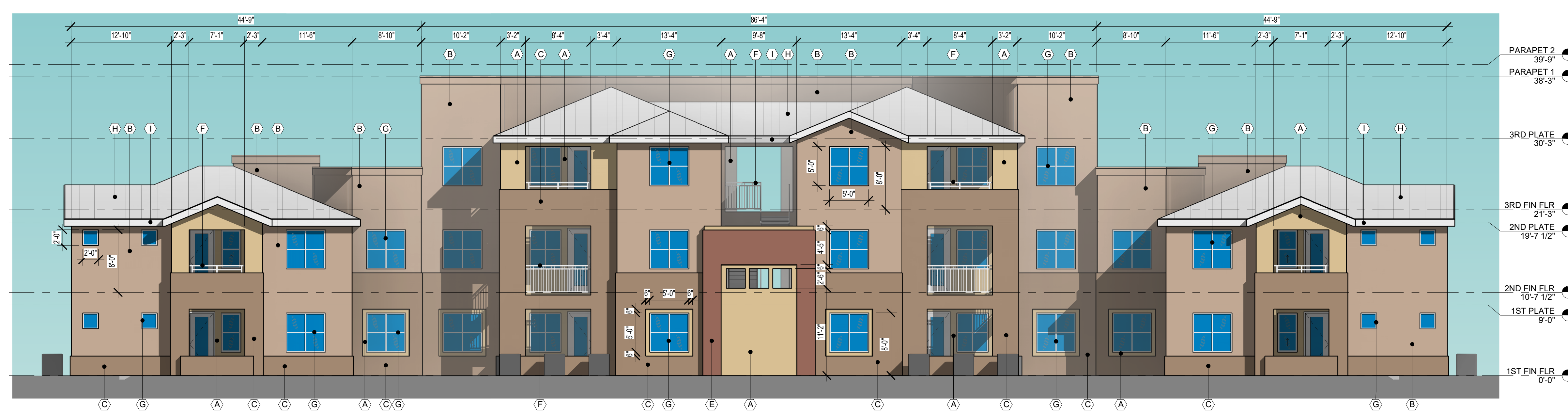

4 BLDG TYPE 2 - REAR ELEVATION  
SCALE: 1/8" = 1'-0"

**ALLASO HIGH DESERT**  
SWC TENNYSON STREET AND SAN ANTONIO DR.  
ALBUQUERQUE, NEW MEXICO

Office of Rich Barber  
**ORB** Architecture  
WorldHQ@ORBArch.com



**TITAN** DEVELOPMENT

DRB SUBMITTAL  
DATE: OCTOBER 5, 2020 ORB #: 19-209  
**A3.25C**  
BUILDING TYPE 2 - COLOR  
EXTERIOR ELEVATIONS

10/11/2020 8:14:01 AM  
Tennison Apartments/19209 Tennison 2020.rvt  
BIM 360://19-

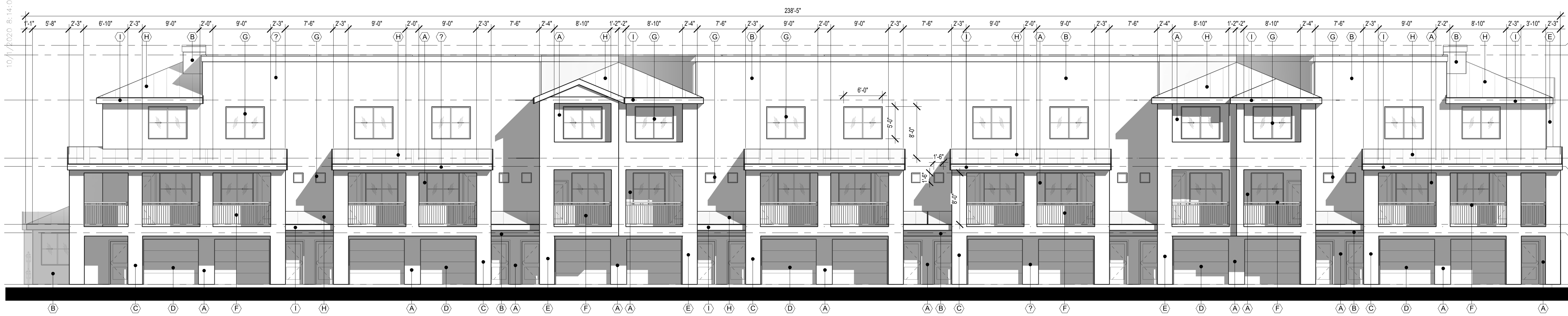

1 BLDG #3 - FRONT ELEVATION  
SCALE: 1/8" = 1'-0"

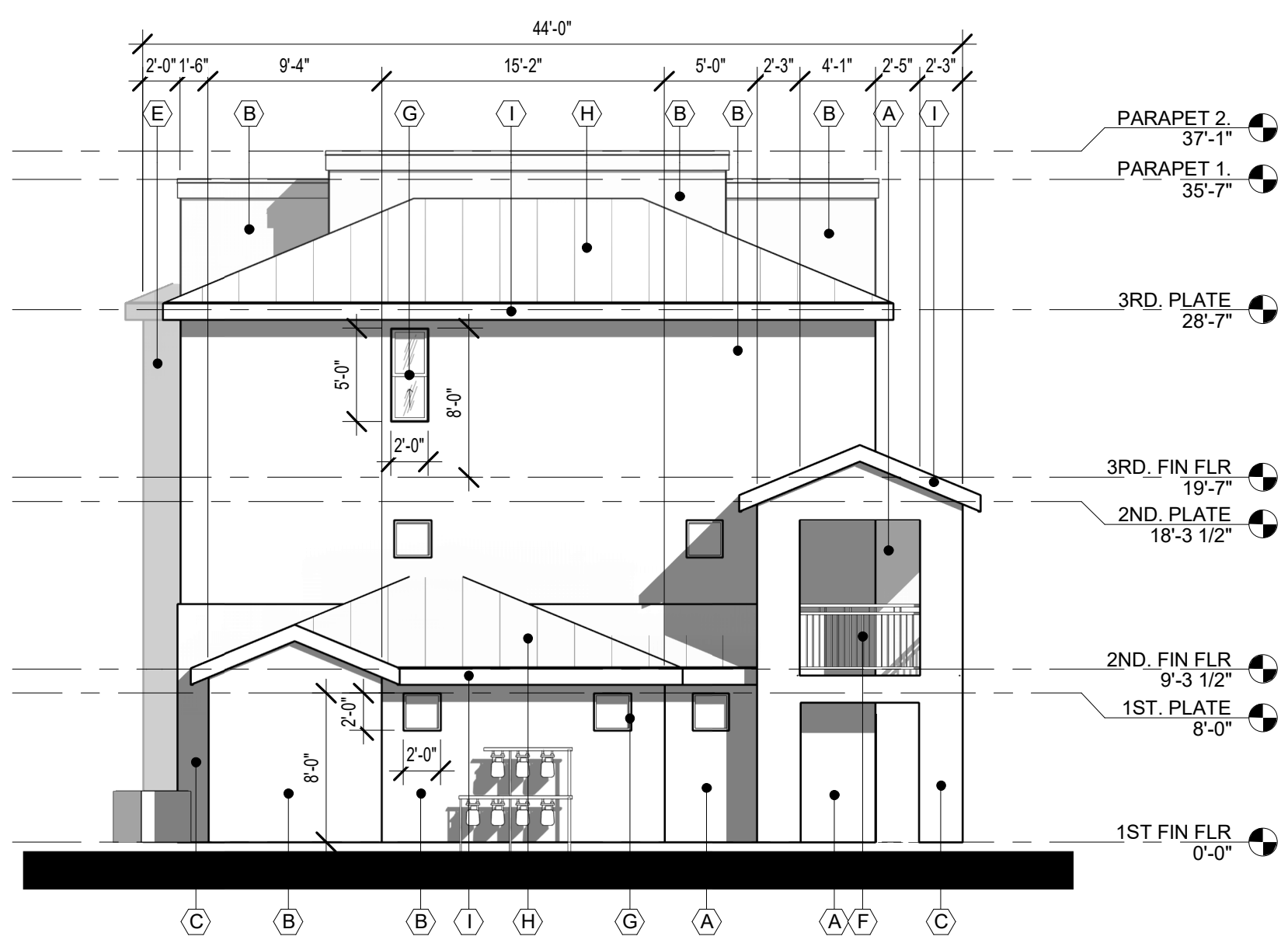

3 BLDG #3 - LEFT ELEVATION  
SCALE: 1/8" = 1'-0"

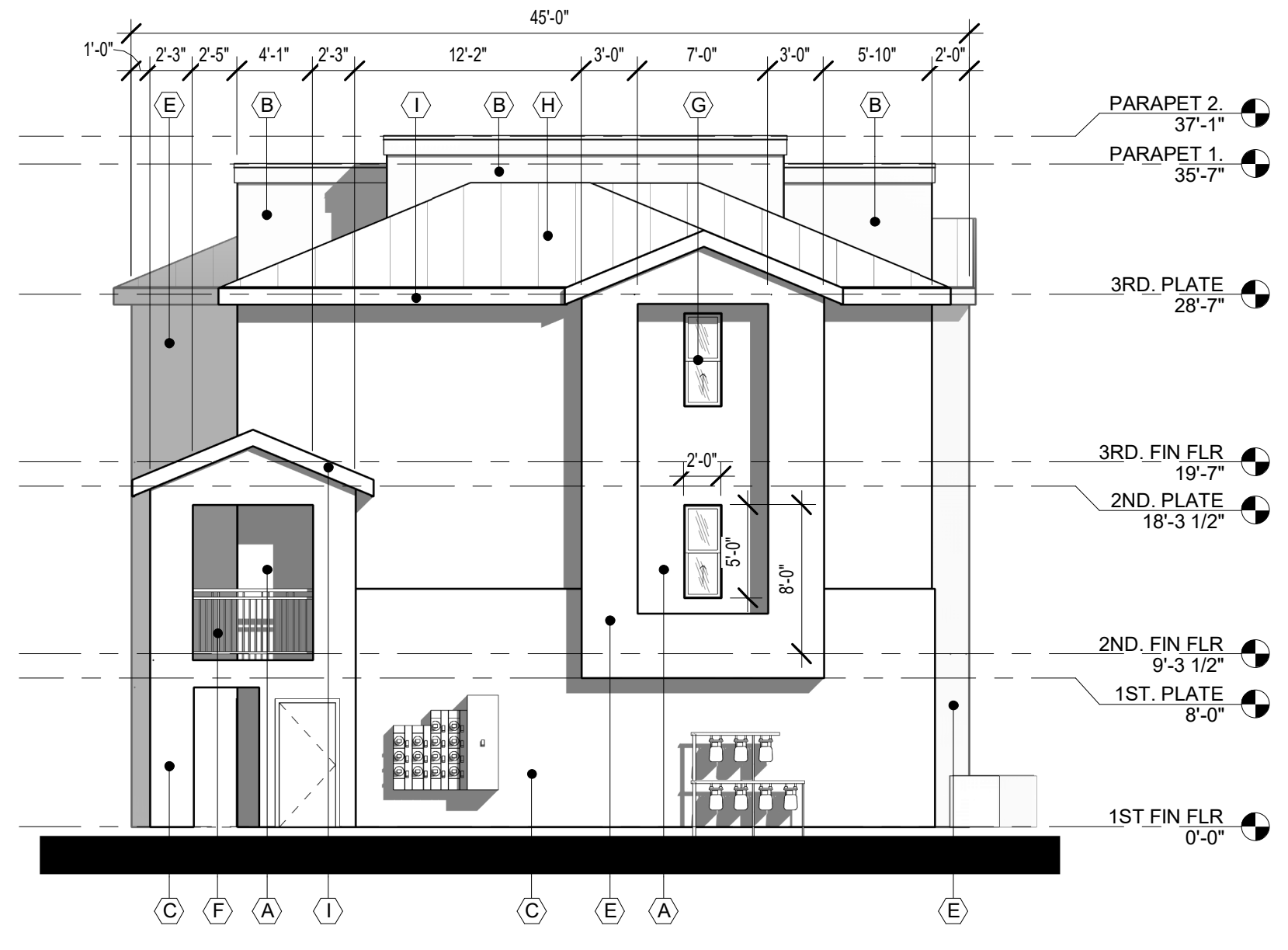

2 BLDG #3 - RIGHT ELEVATION  
SCALE: 1/8" = 1'-0"

MATERIAL AND COLOR KEY

A	STUCCO LIGHT YELLOW LRV 50
B	STUCCO LIGHT BROWN LRV 42
C	STUCCO DARK BROWN LRV 27
D	GARAGE DOOR PAINTED DARK BROWN LRV 27
E	STUCCO LIGHT RED LRV 20
F	METAL RAILINGS COLOR WHITE
G	VINYL WINDOWS COLOR WHITE
H	GREY METAL ROOF LRV TO BE BETWEEN 20 & 50
I	METAL FASCIA COLOR WHITE

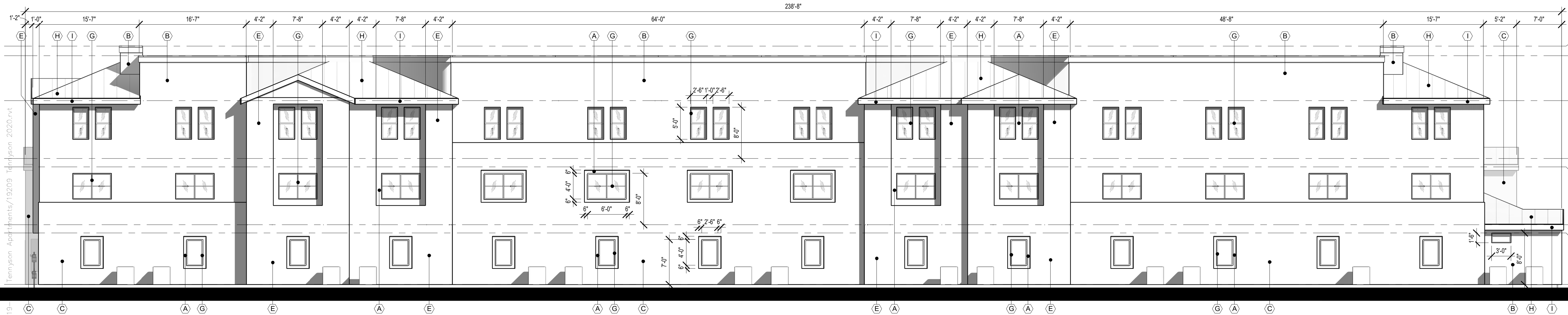

4 BLDG #3 - REAR ELEVATION  
SCALE: 1/8" = 1'-0"

**ALLASO HIGH DESERT**  
SWC TENNISON STREET AND SAN ANTONIO DR.  
ALBUQUERQUE, NEW MEXICO

Office of Rich Barber  
**ORB** Architecture  
WorldHQ@ORBArch.com



**TITAN** DEVELOPMENT

DRB SUBMITTAL  
DATE: OCTOBER 5, 2020 DRB #: 19-209

**A3.33**  
BUILDING #3 - EXTERIOR ELEVATIONS

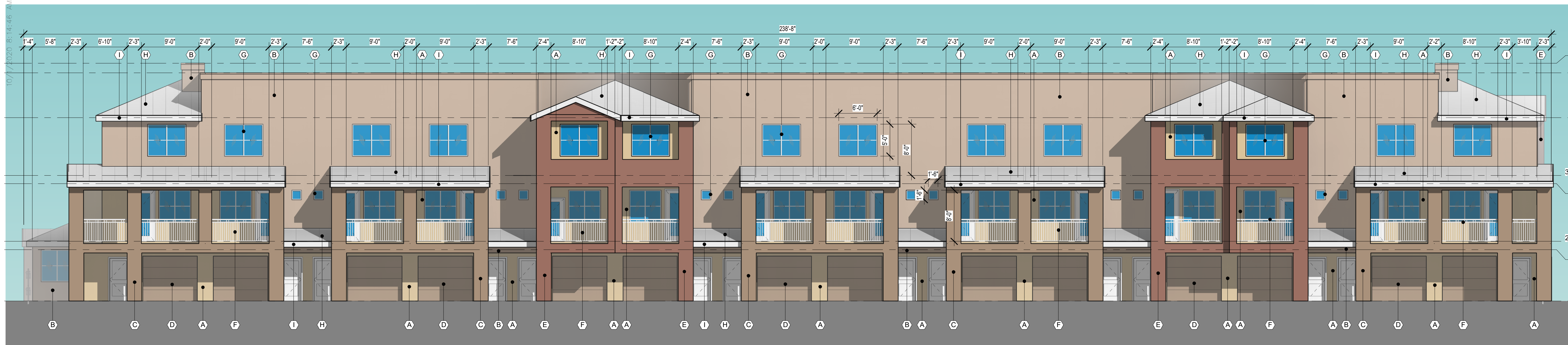

1 BLDG #3 - FRONT ELEVATION  
SCALE: 1/8" = 1'-0"

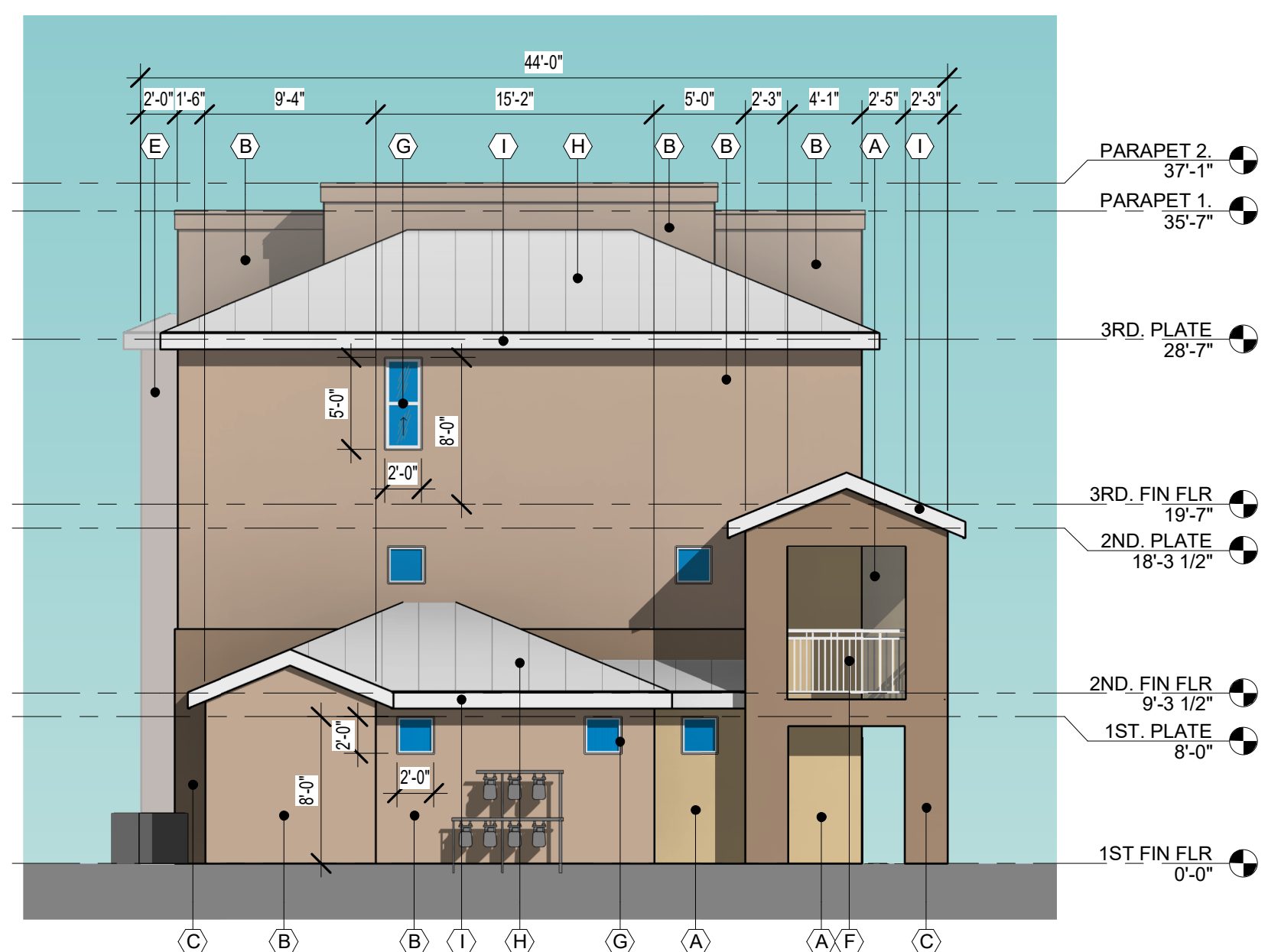

3 BLDG #3 - LEFT ELEVATION  
SCALE: 1/8" = 1'-0"

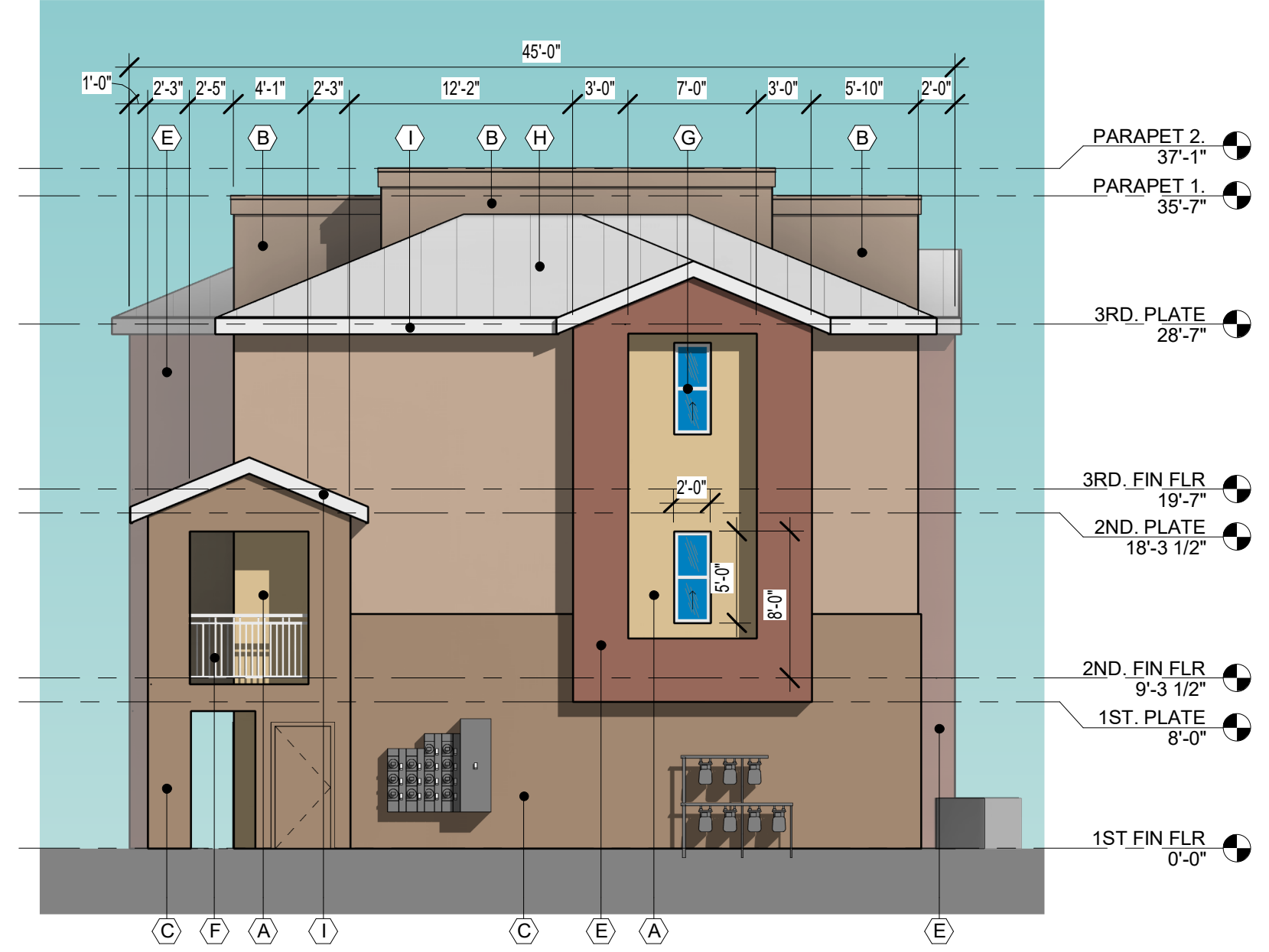

2 BLDG #3 - RIGHT ELEVATION  
SCALE: 1/8" = 1'-0"

MATERIAL AND COLOR KEY

A	STUCCO LIGHT YELLOW LRV 50
B	STUCCO LIGHT BROWN LRV 42
C	STUCCO DARK BROWN LRV 27
D	GARAGE DOOR PAINTED DARK BROWN LRV 27
E	STUCCO LIGHT RED LRV 20
F	METAL RAILINGS COLOR WHITE
G	VINYL WINDOWS COLOR WHITE
H	GREY METAL ROOF LRV TO BE BETWEEN 20 & 50
I	METAL FASCIA COLOR WHITE

**ALLASO HIGH DESERT**  
SWC TENNYSON STREET AND SAN ANTONIO DR.  
ALBUQUERQUE, NEW MEXICO

Office of Rich Barber  
**ORB** Architecture  
WorldHQ@ORBArch.com



TITAN DEVELOPMENT

DRB SUBMITTAL  
DATE: OCTOBER 5, 2020 DRB #: 19-209

**A3.33C**  
BUILDING #3 - COLOR EXTERIOR ELEVATIONS

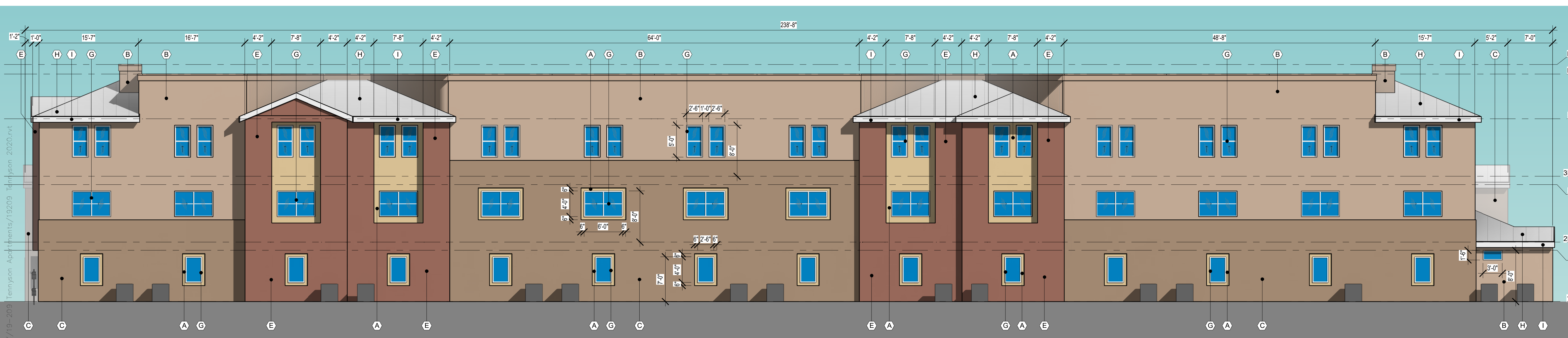

4 BLDG #3 - REAR ELEVATION  
SCALE: 1/8" = 1'-0"

BIM 360://19-209-Tennyson-App4/Plans/19209-Tennyson-2020.rvt



**MATERIAL AND COLOR KEY**

A	STUCCO LIGHT YELLOW LRV 50
B	STUCCO LIGHT BROWN LRV 42
C	STUCCO DARK BROWN LRV 27
D	GARAGE DOOR PAINTED DARK BROWN LRV 27
E	STUCCO LIGHT RED LRV 20
F	METAL RAILINGS COLOR WHITE
G	VINYL WINDOWS COLOR WHITE
H	GREY METAL ROOF LRV TO BE BETWEEN 20 & 50
I	METAL FASCIA COLOR WHITE

**ALLASO HIGH DESERT**  
SWC TENNYSON STREET AND SAN ANTONIO DR.  
ALBUQUERQUE, NEW MEXICO

Office of Rich Barber  
**ORB** Architecture  
WorldHQ@ORBArch.com

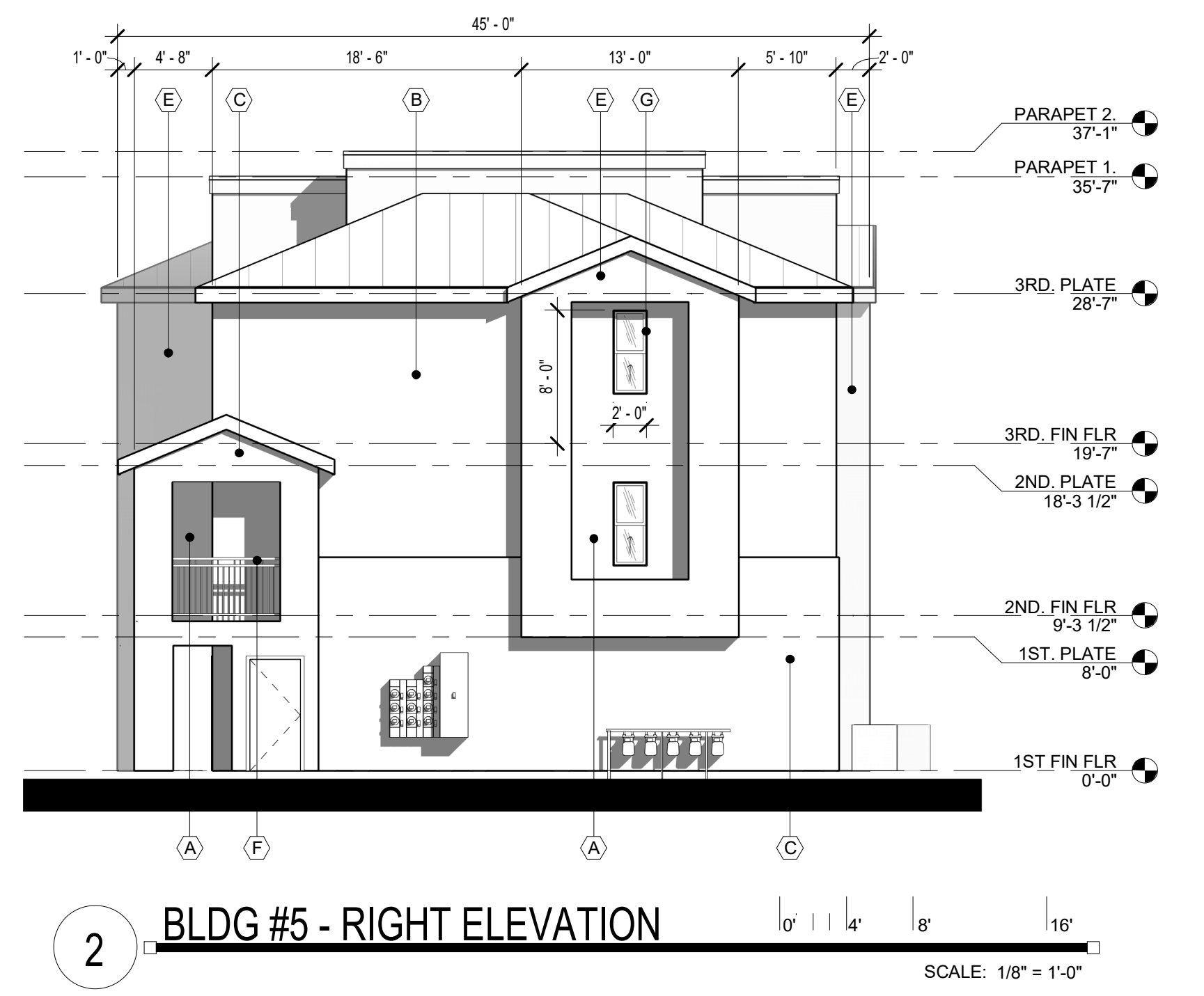
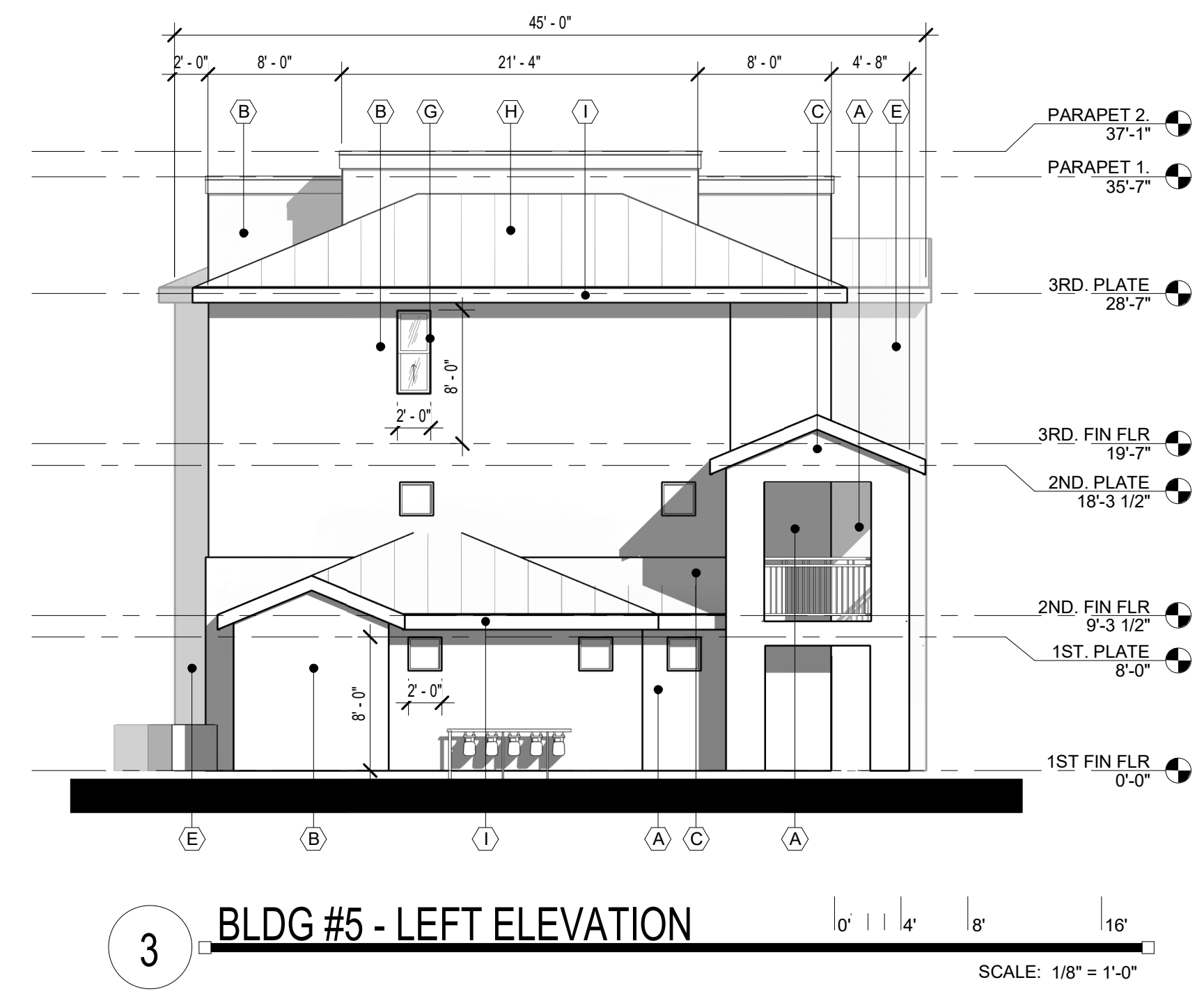

DRB SUBMITTAL  
DATE: OCTOBER 5, 2020 ORB #: 19-209

**A3.43**  
BUILDING #5 - EXTERIOR ELEVATIONS

10/1/2020 8:16:07 AM

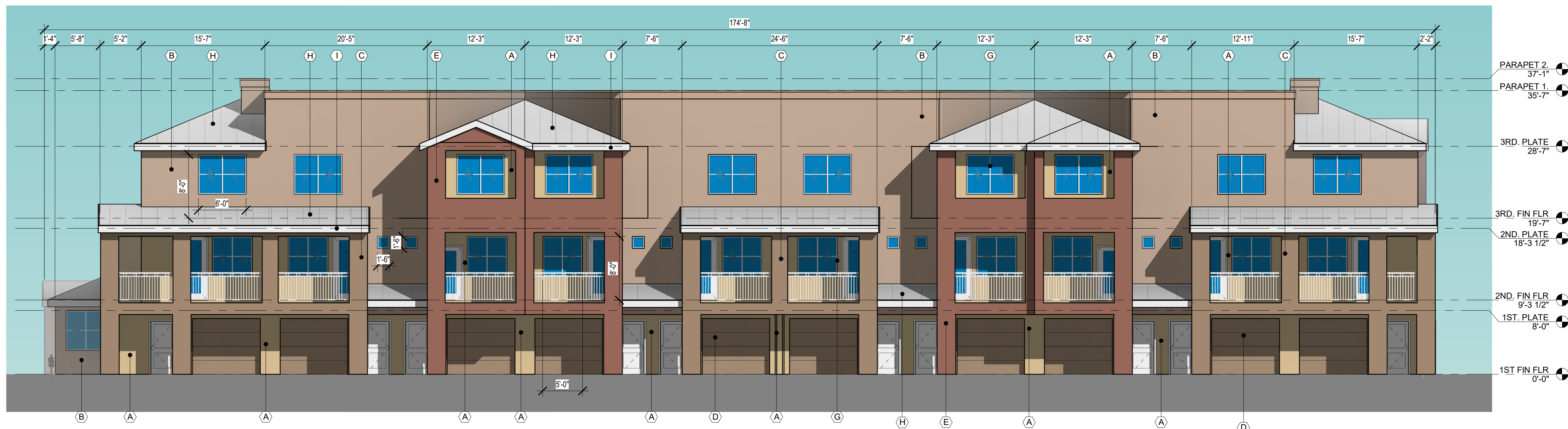

1 BLDG #5 - FRONT ELEVATION  
SCALE: 1/8" = 1'-0"

**MATERIAL AND COLOR KEY**

A	STUCCO LIGHT YELLOW LRV 50
B	STUCCO LIGHT BROWN LRV 42
C	STUCCO DARK BROWN LRV 27
D	GARAGE DOOR PAINTED DARK BROWN LRV 27
E	STUCCO LIGHT RED LRV 20
F	METAL RAILINGS COLOR WHITE
G	VINYL WINDOWS COLOR WHITE
H	GREY METAL ROOF LRV TO BE BETWEEN 20 & 50
I	METAL FASCIA COLOR WHITE

**ALLASO HIGH DESERT**  
SWC TENNYSON STREET AND SAN ANTONIO DR.  
ALBUQUERQUE, NEW MEXICO

Office of Rich Barber  
**ORB** Architecture  
WorldHQ@ORBArch.com



**TITAN** DEVELOPMENT

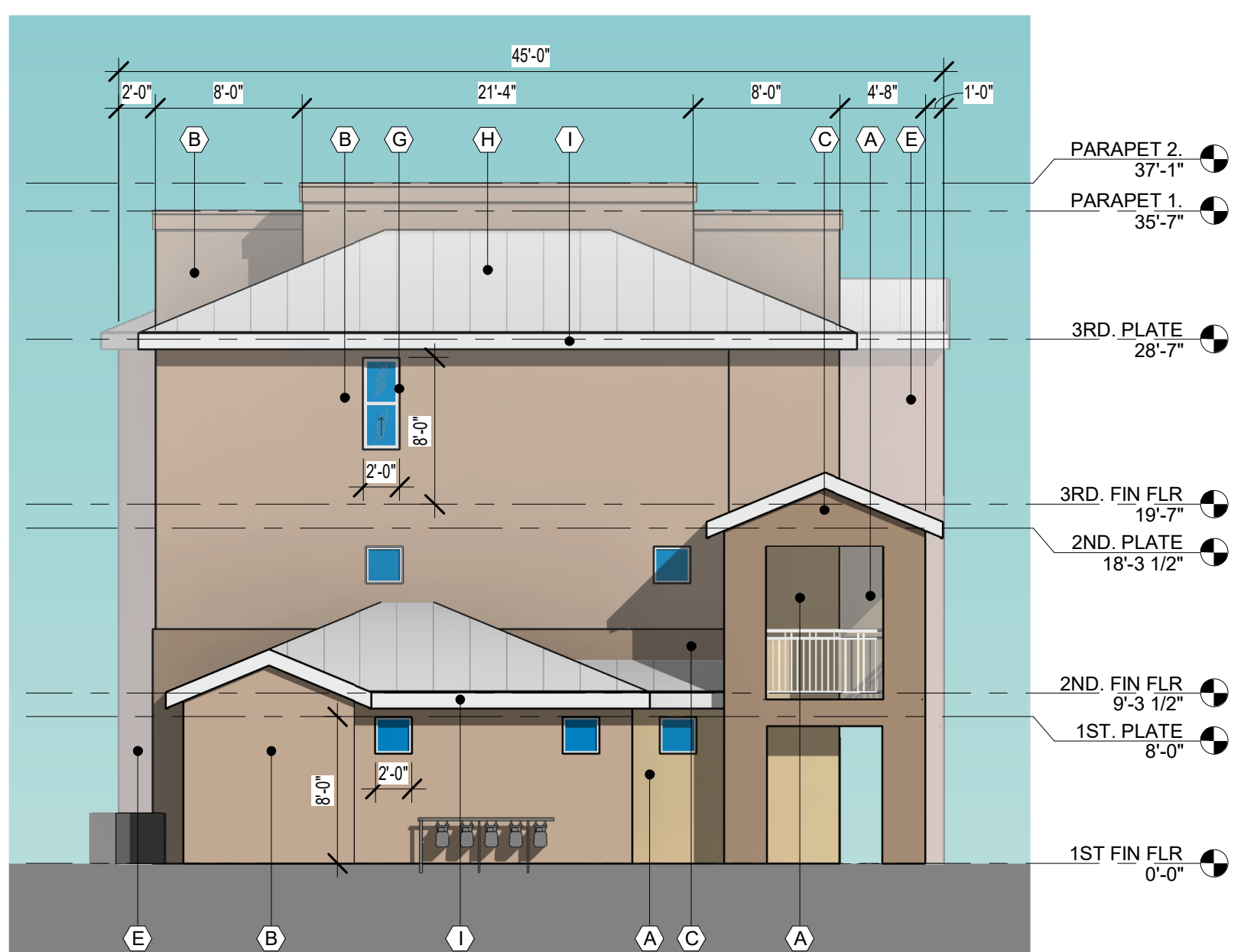

3 BLDG #5 - LEFT ELEVATION  
SCALE: 1/8" = 1'-0"

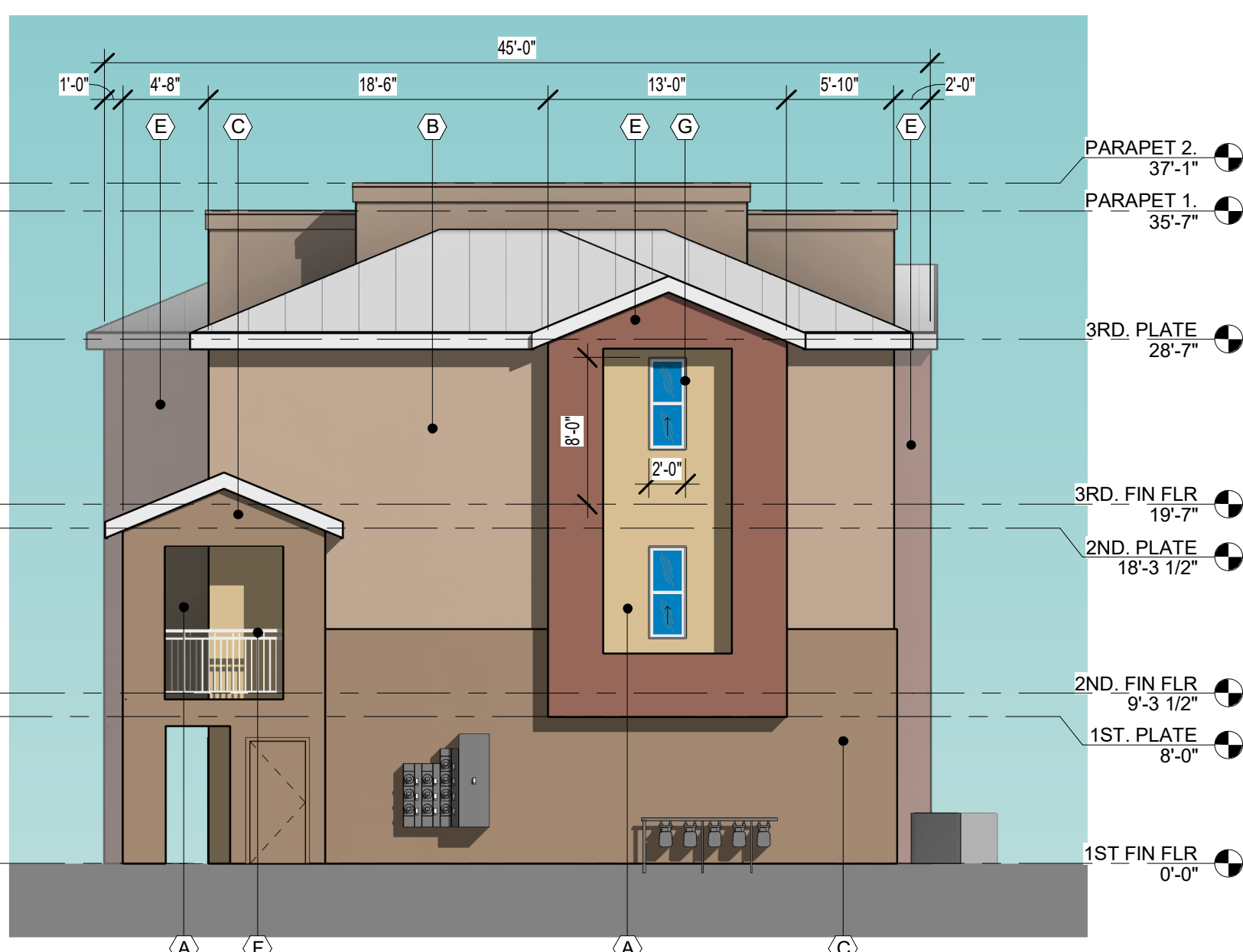

2 BLDG #5 - RIGHT ELEVATION  
SCALE: 1/8" = 1'-0"

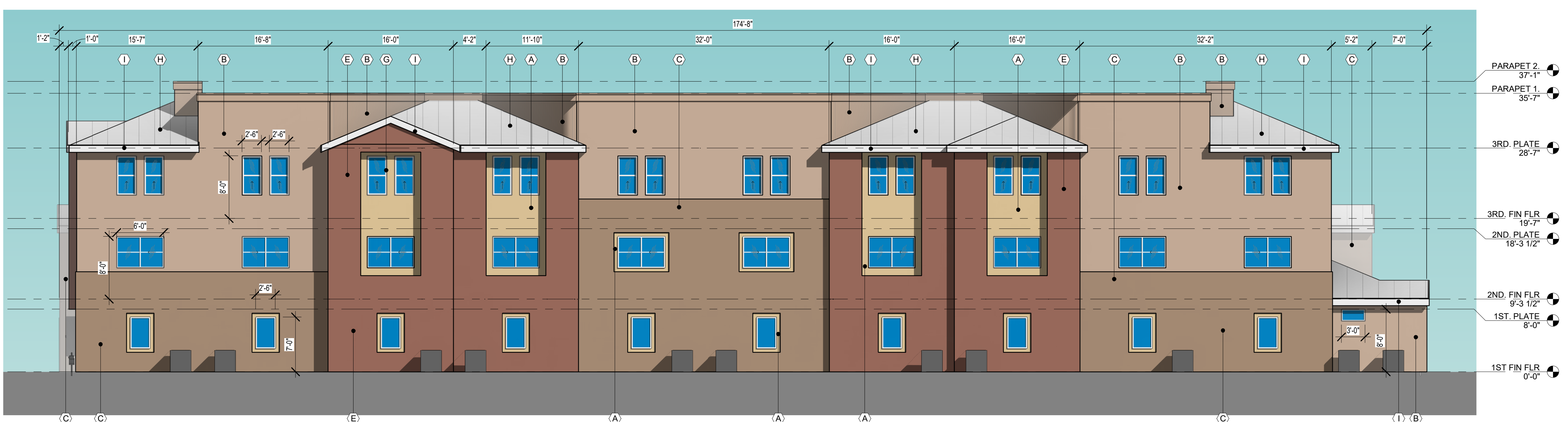

4 BLDG #5 - REAR ELEVATION  
SCALE: 1/8" = 1'-0"

BIM 360://19-209 Tennyson Apartments/19209 Tennyson 2020.rvt

DRB SUBMITTAL  
DATE: OCTOBER 5, 2020 ORB #: 19-209

**A3.43C**  
BUILDING #5 - COLOR EXTERIOR ELEVATIONS

MATERIAL AND COLOR KEY

A	STUCCO LIGHT YELLOW LRV 50
B	STUCCO LIGHT BROWN LRV 42
C	STUCCO DARK BROWN LRV 27
D	GARAGE DOOR PAINTED DARK BROWN LRV 27
E	STUCCO LIGHT RED LRV 20
F	METAL RAILINGS COLOR WHITE
G	VINYL WINDOWS COLOR WHITE
H	GREY METAL ROOF LRV TO BE BETWEEN 20 & 50
I	METAL FASCIA COLOR WHITE

**ALLASO  
HIGH DESERT**  
SWC TENNYSON STREET AND SAN ANTONIO DR.  
ALBUQUERQUE, NEW MEXICO

Office of Rich Barber  
**ORB**  
Architecture  
WorldHQ@ORBArch.com



**TITAN**  
DEVELOPMENT



1 BLDG #7 - FRONT ELEVATION  
SCALE: 1/8" = 1'-0"

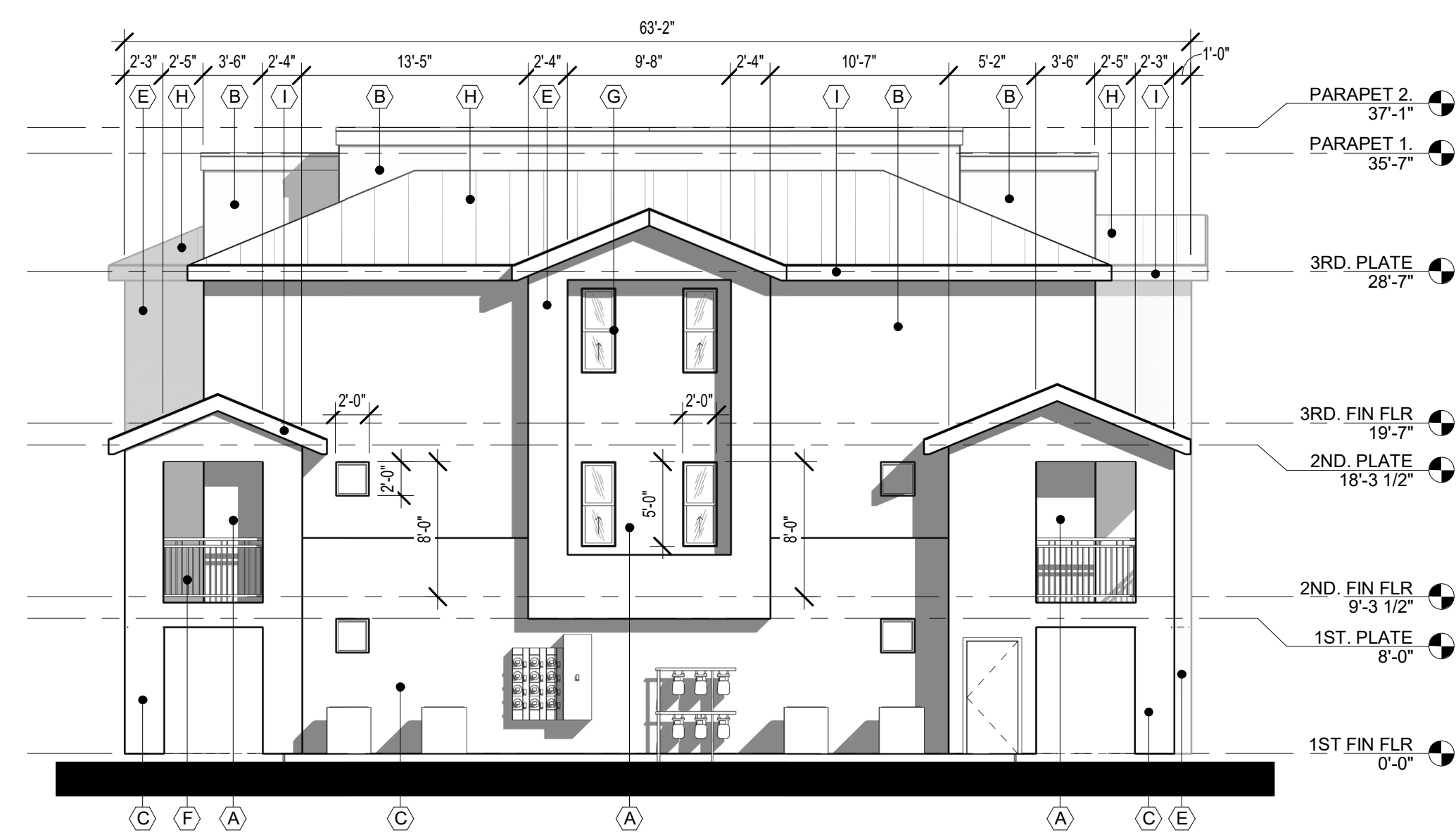

3 BLDG #7 - LEFT ELEVATION  
SCALE: 1/8" = 1'-0"

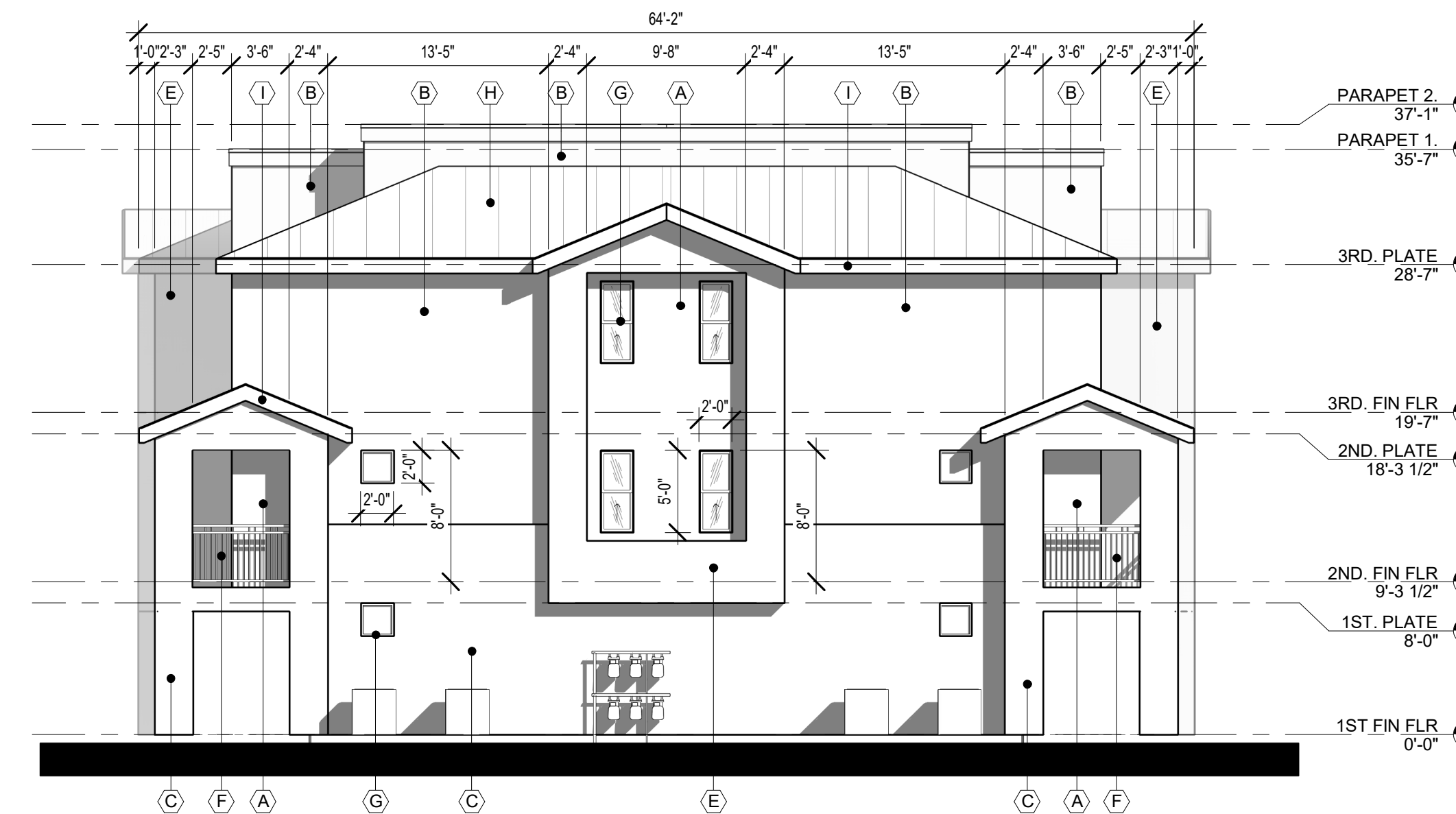

2 BLDG #7 - RIGHT ELEVATION  
SCALE: 1/8" = 1'-0"

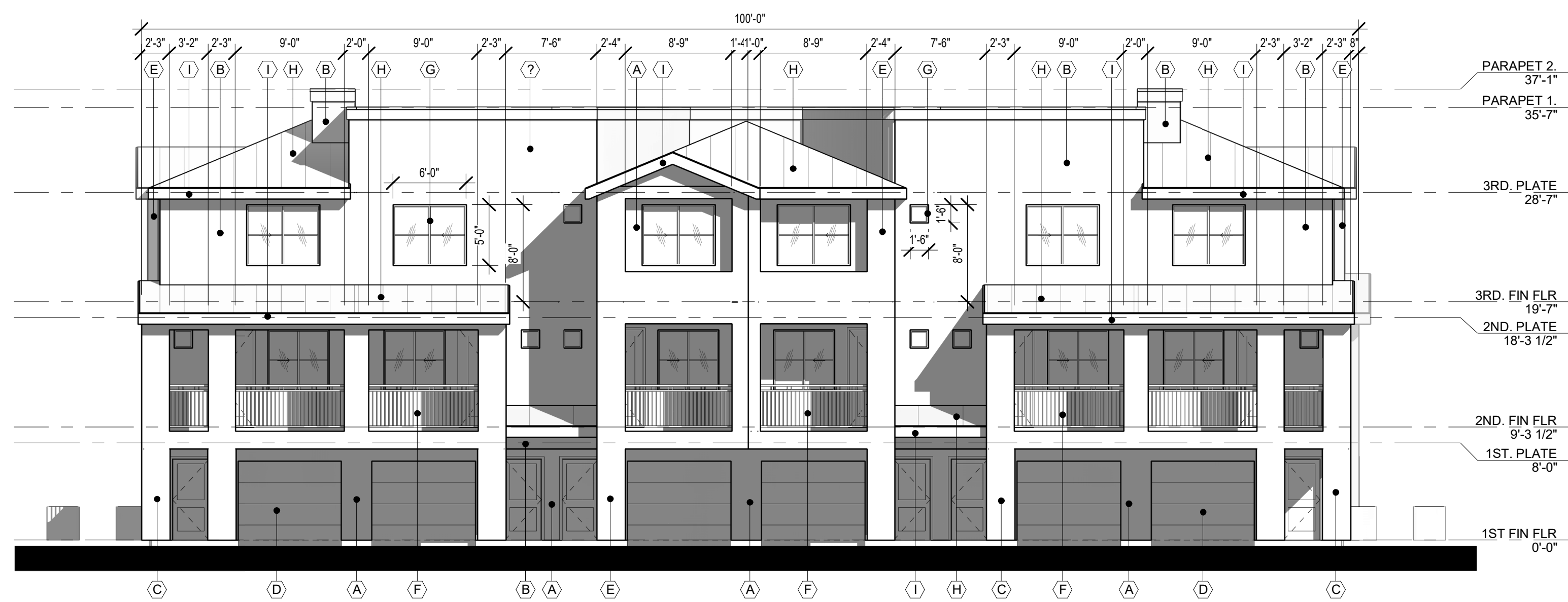

4 BLDG #7 - REAR ELEVATION  
SCALE: 1/8" = 1'-0"

DRB SUBMITTAL  
DATE: OCTOBER 5, 2020 DRB #: 19-209

**A3.53**  
BUILDING #7 - EXTERIOR  
ELEVATIONS

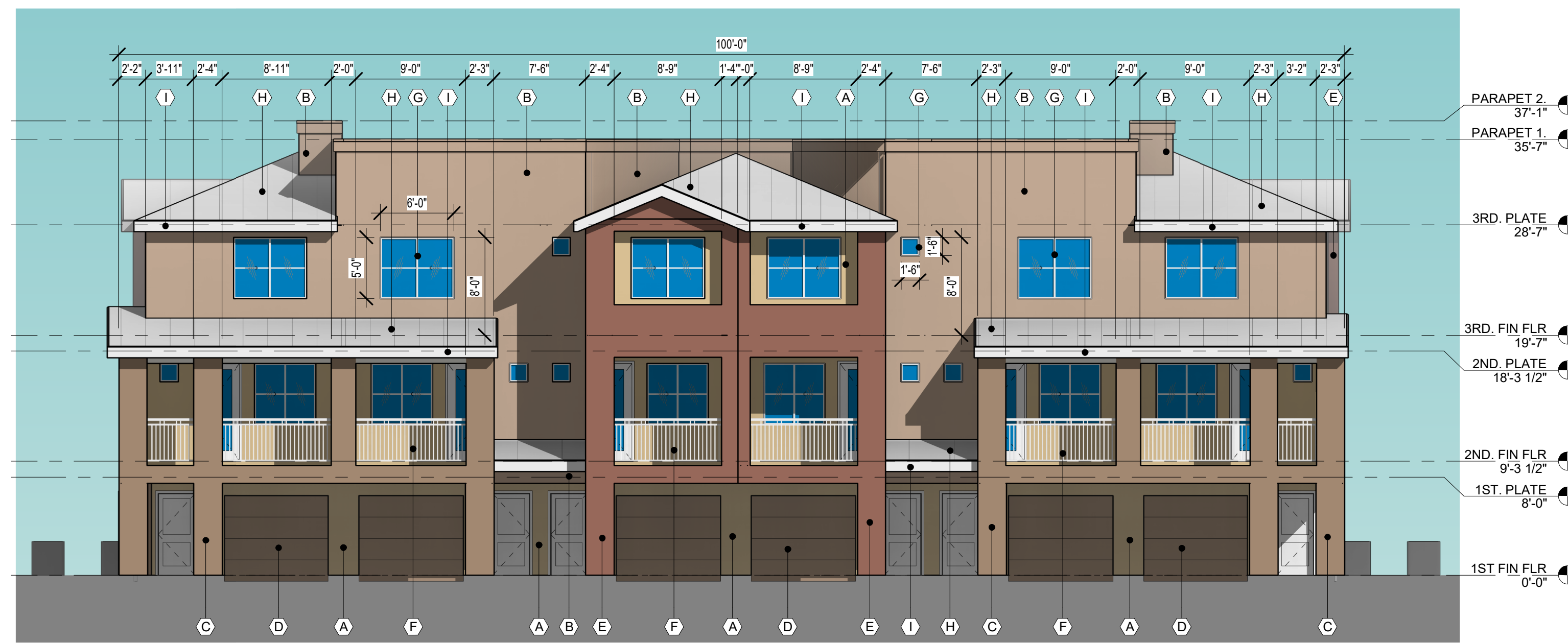

1 BLDG #7 - FRONT ELEVATION  
SCALE: 1/8" = 1'-0"

**MATERIAL AND COLOR KEY**

A	STUCCO LIGHT YELLOW LRV 50
B	STUCCO LIGHT BROWN LRV 42
C	STUCCO DARK BROWN LRV 27
D	GARAGE DOOR PAINTED DARK BROWN LRV 27
E	STUCCO LIGHT RED LRV 20
F	METAL RAILINGS COLOR WHITE
G	VINYL WINDOWS COLOR WHITE
H	GREY METAL ROOF LRV TO BE BETWEEN 20 & 50
I	METAL FASCIA COLOR WHITE

**ALLASO HIGH DESERT**  
SWC TENNYSON STREET AND SAN ANTONIO DR.  
ALBUQUERQUE, NEW MEXICO

Office of Rich Barber  
**ORB** Architecture  
WorldHQ@ORBArch.com



**TITAN** DEVELOPMENT

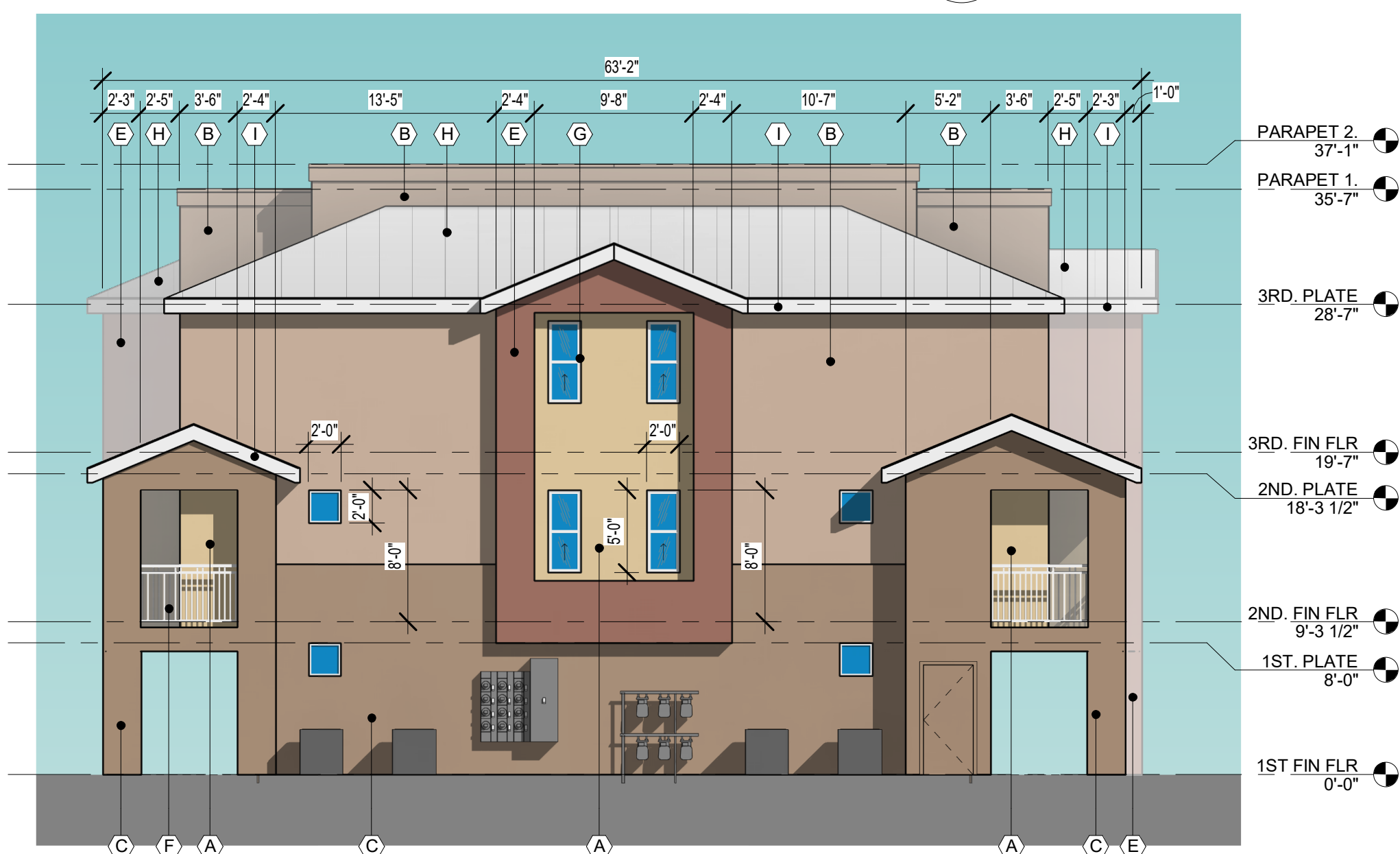

3 BLDG #7 - LEFT ELEVATION  
SCALE: 1/8" = 1'-0"

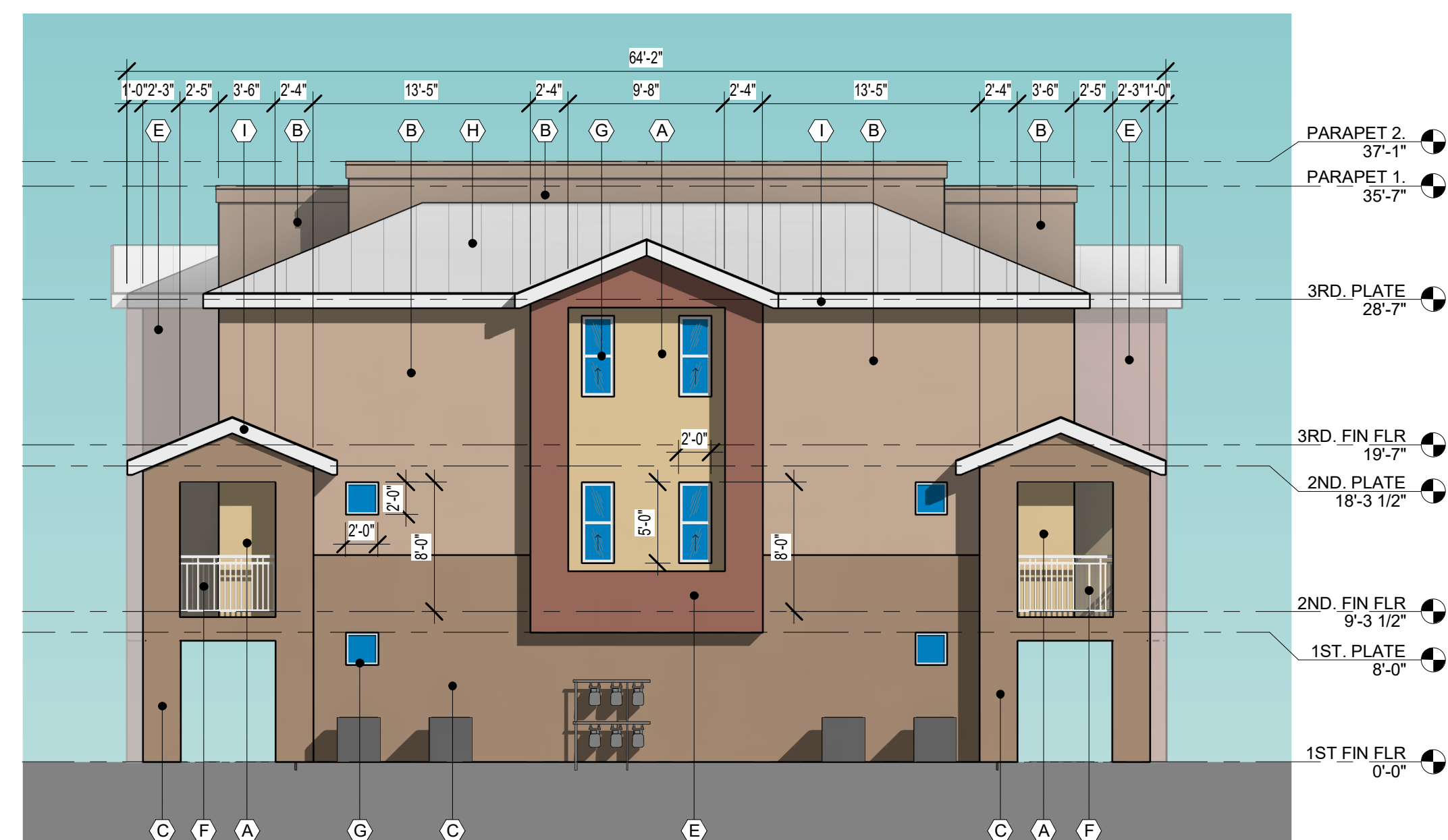

2 BLDG #7 - RIGHT ELEVATION  
SCALE: 1/8" = 1'-0"

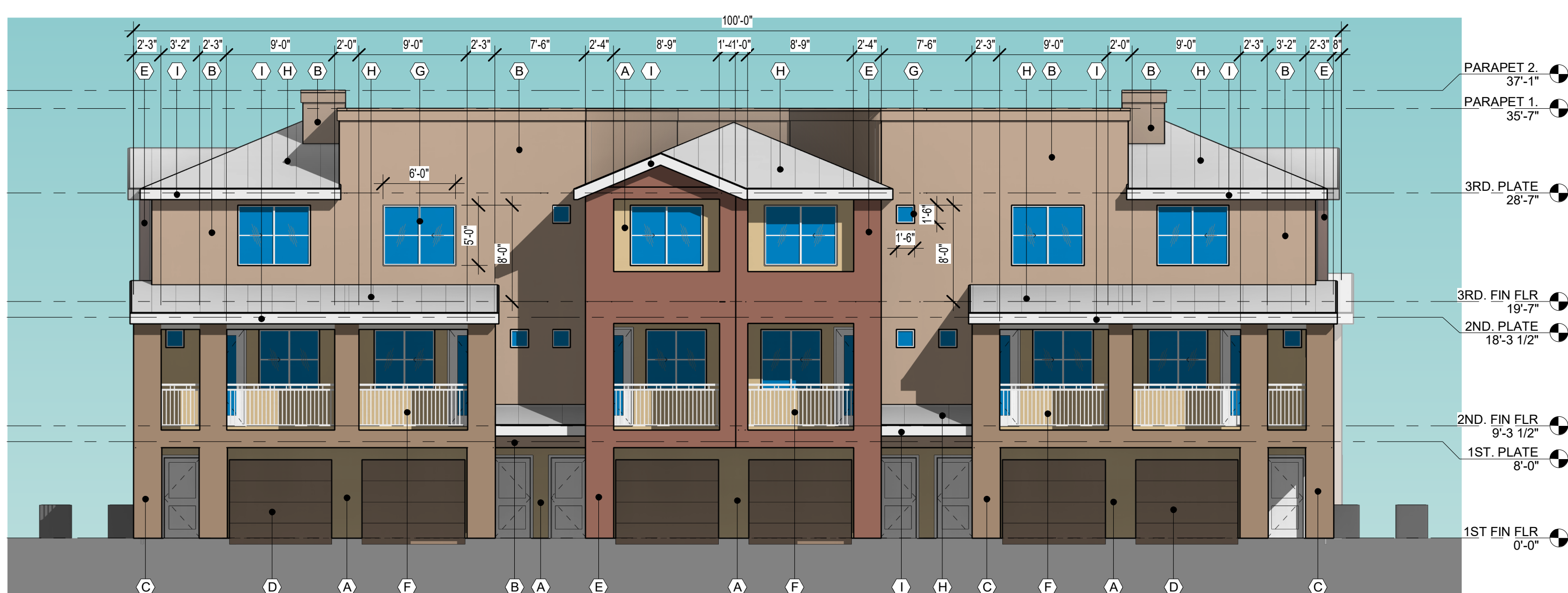

4 BLDG #7 - REAR ELEVATION  
SCALE: 1/8" = 1'-0"

DRB SUBMITTAL  
DATE: OCTOBER 5, 2020 DRB #: 19-209  
**A3.53C**  
BUILDING #7 - COLOR EXTERIOR ELEVATIONS

MATERIAL AND COLOR KEY

A	STUCCO LIGHT YELLOW LRV 50
B	STUCCO LIGHT BROWN LRV 42
C	STUCCO DARK BROWN LRV 27
D	GARAGE DOOR PAINTED DARK BROWN LRV 27
E	STUCCO LIGHT RED LRV 20
F	METAL RAILINGS COLOR WHITE
G	VINYL WINDOWS COLOR WHITE
H	GREY METAL ROOF LRV TO BE BETWEEN 20 & 50
I	METAL FASCIA COLOR WHITE

**ALLASO  
HIGH DESERT**  
SWC TENNYSON STREET AND SAN ANTONIO DR.  
ALBUQUERQUE, NEW MEXICO

Office of Rich Barber  
**ORB**  
Architecture, LLC  
WorldHQ@ORBArch.com



**TITAN**  
DEVELOPMENT

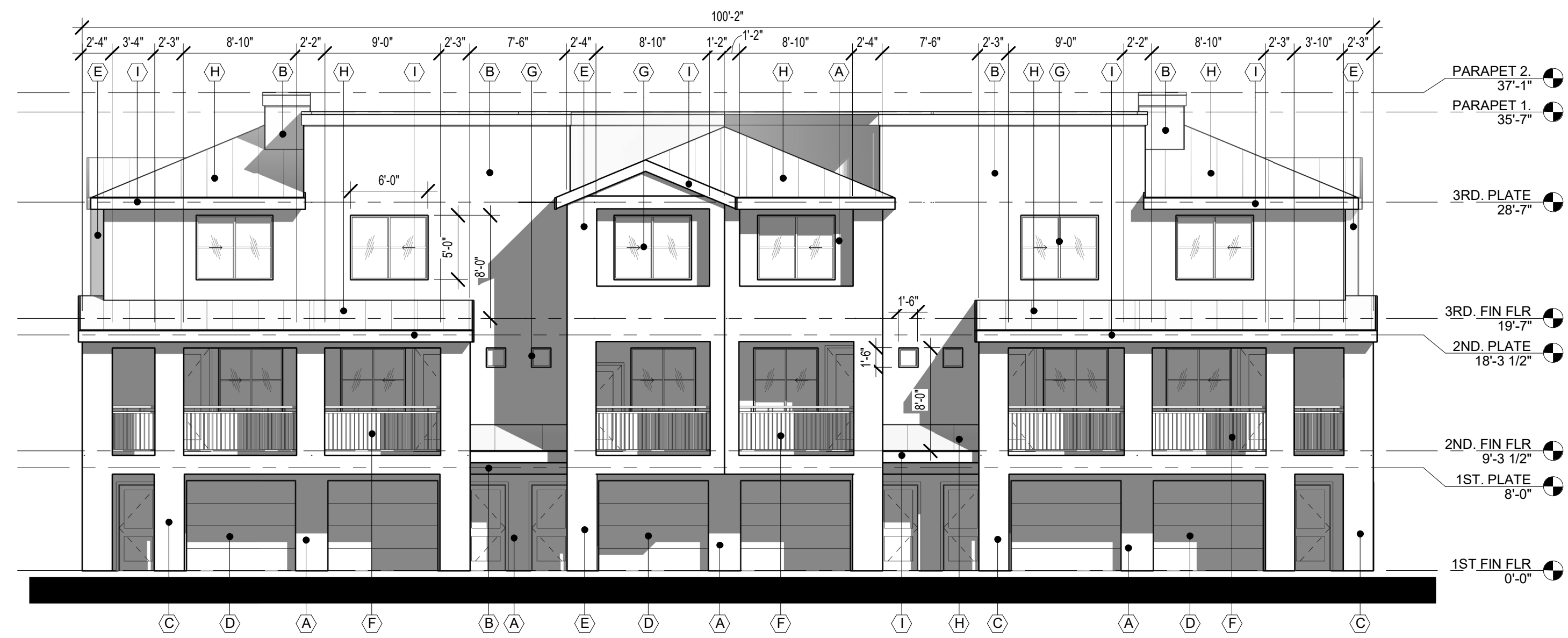

1 BLDG #15 - FRONT ELEVATION  
SCALE: 1/8" = 1'-0"

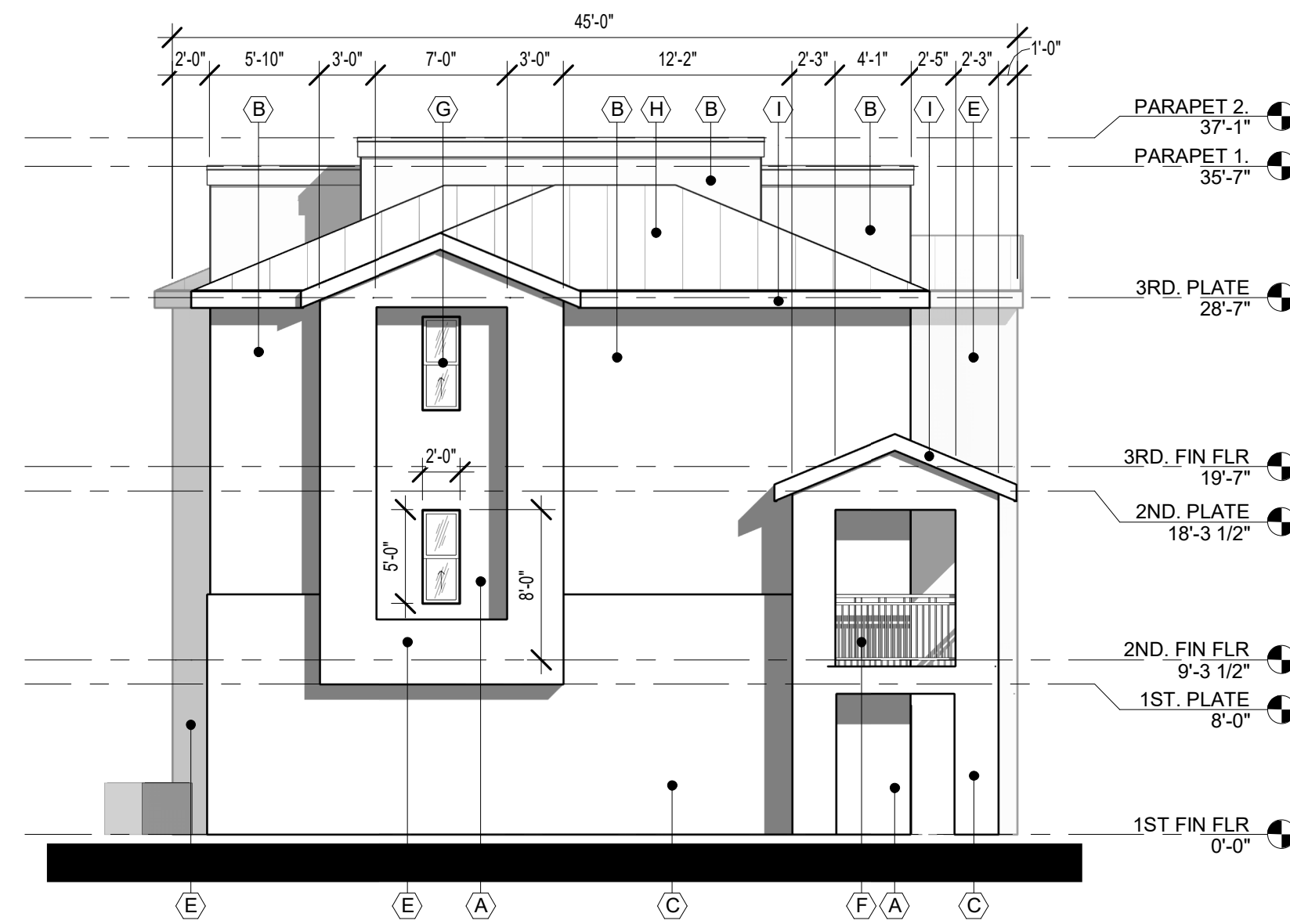

3 BLDG #15 - LEFT ELEVATION  
SCALE: 1/8" = 1'-0"

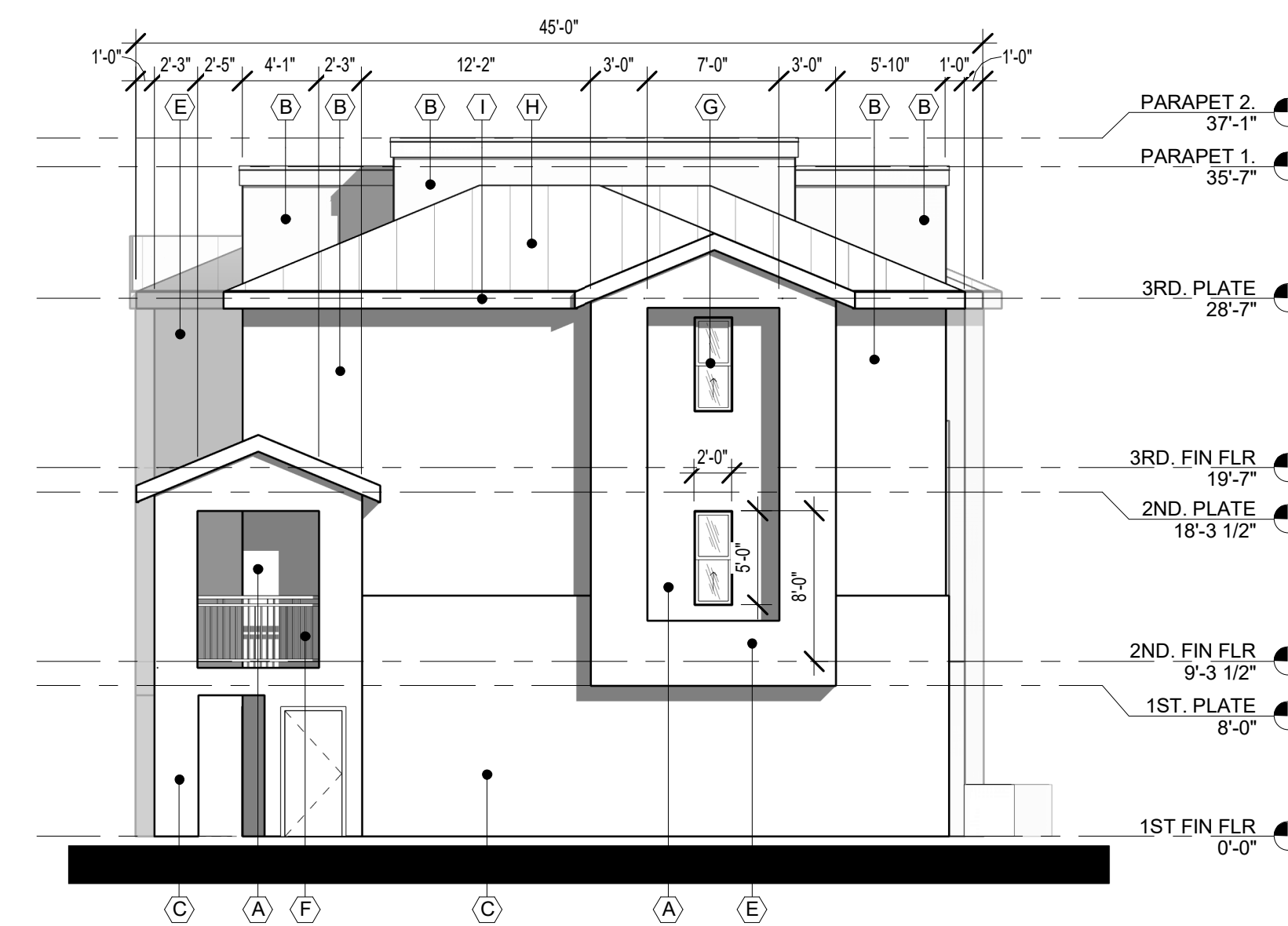

2 BLDG #15 - RIGHT ELEVATION  
SCALE: 1/8" = 1'-0"



4 BLDG #15 - REAR ELEVATION  
SCALE: 1/8" = 1'-0"

DRB SUBMITTAL  
DATE: OCTOBER 5, 2020 ORB #: 19-209

**A3.63**  
BUILDING #15 - EXTERIOR  
ELEVATIONS



**MATERIAL AND COLOR KEY**

A	STUCCO LIGHT YELLOW LRV 50
B	STUCCO LIGHT BROWN LRV 42
C	STUCCO DARK BROWN LRV 27
D	GARAGE DOOR PAINTED DARK BROWN LRV 27
E	STUCCO LIGHT RED LRV 20
F	METAL RAILINGS COLOR WHITE
G	VINYL WINDOWS COLOR WHITE
H	GREY METAL ROOF LRV TO BE BETWEEN 20 & 50
I	METAL FASCIA COLOR WHITE

**ALLASO  
HIGH DESERT**  
SWC TENNYSON STREET AND SAN ANTONIO DR.  
ALBUQUERQUE, NEW MEXICO

Office of Rich Barber  
**ORB**  
Architecture  
WorldHQ@ORBArch.com



**TITAN**  
DEVELOPMENT

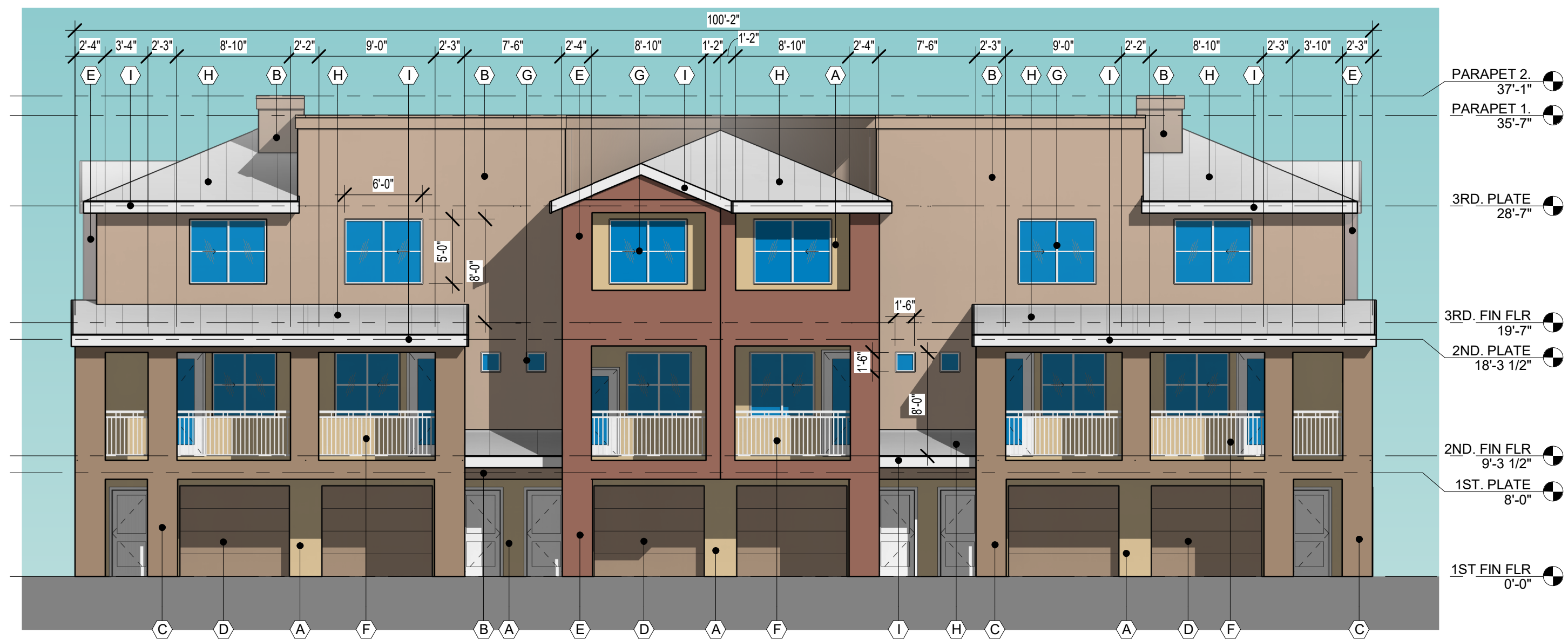

**1 BLDG #15 - FRONT ELEVATION**  
SCALE: 1/8" = 1'-0"

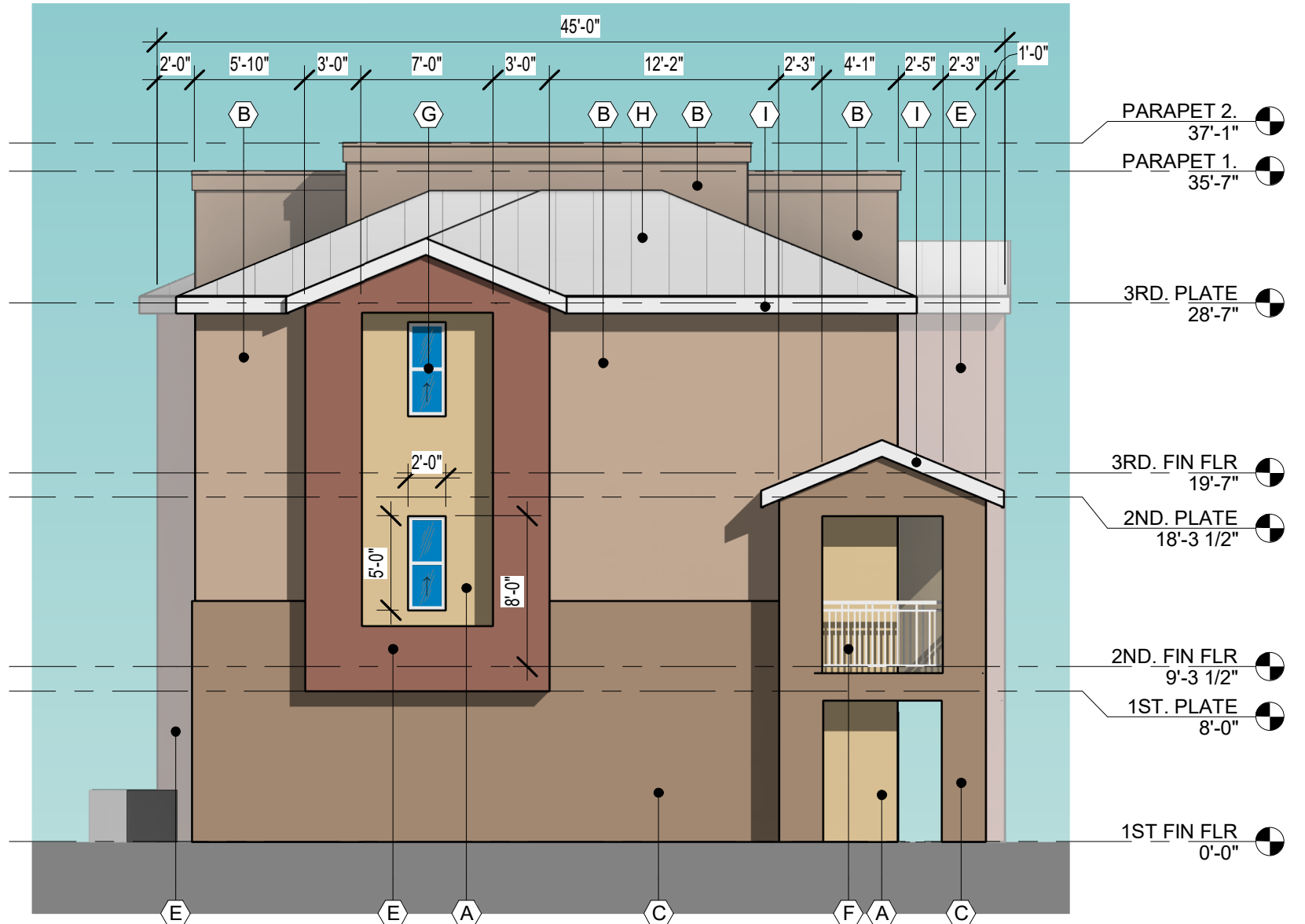

**3 BLDG #15 - LEFT ELEVATION**  
SCALE: 1/8" = 1'-0"

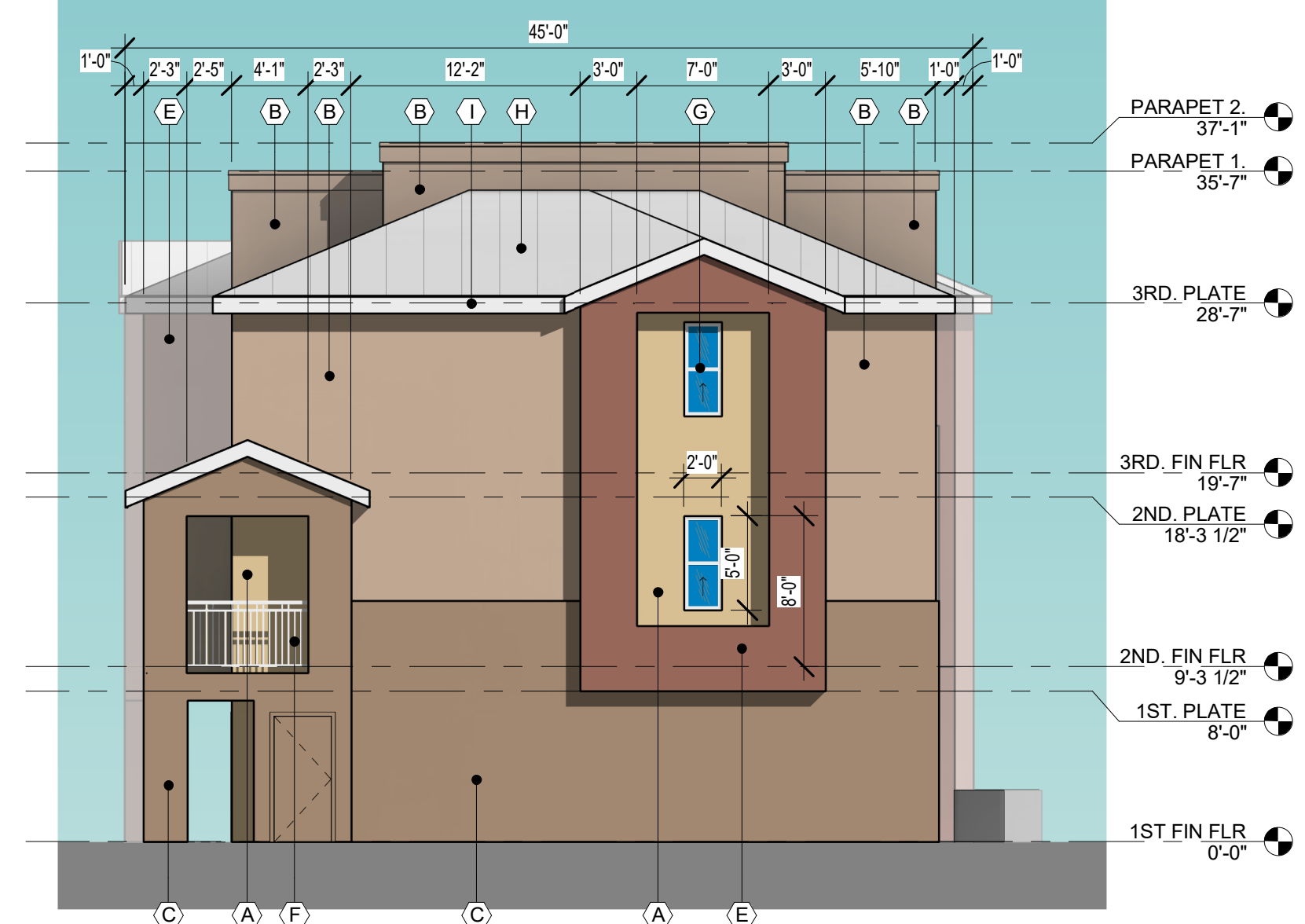

**2 BLDG #15 - RIGHT ELEVATION**  
SCALE: 1/8" = 1'-0"

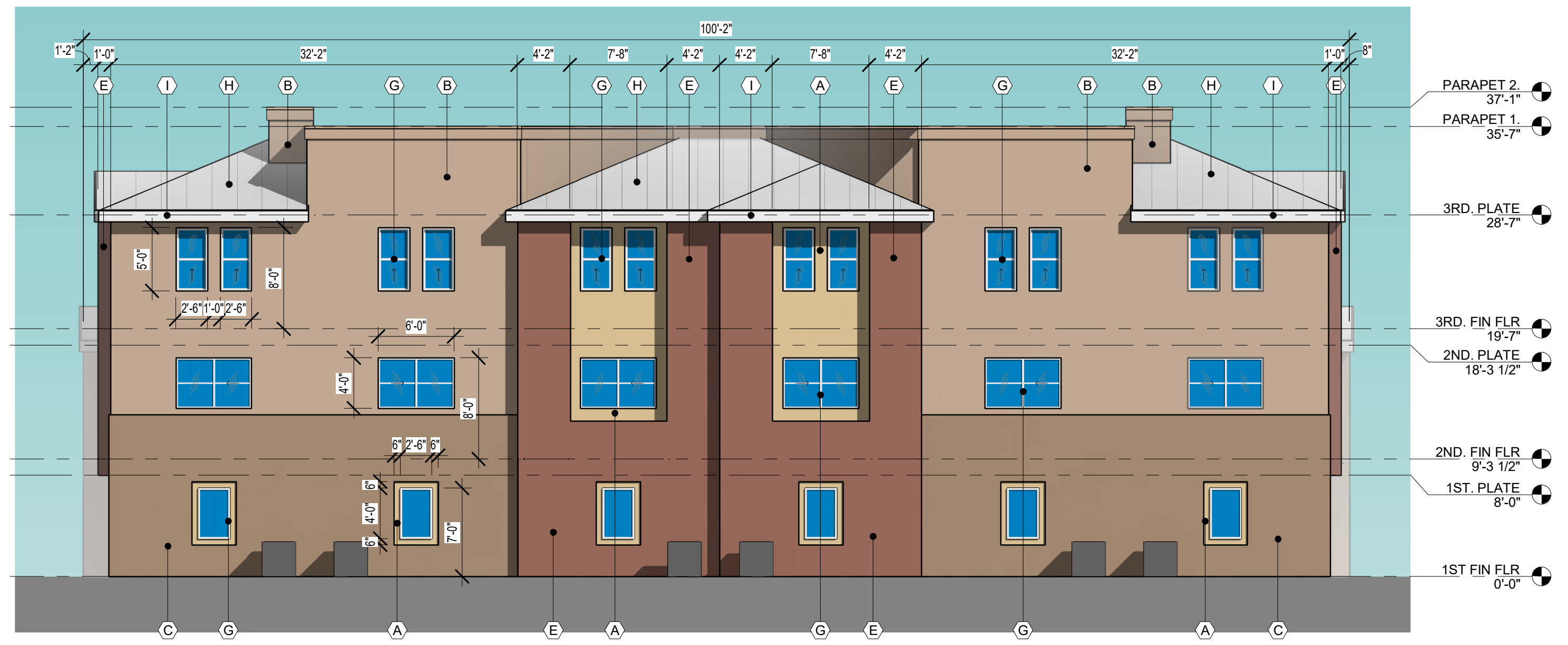

**4 BLDG #15 - REAR ELEVATION**  
SCALE: 1/8" = 1'-0"

DRB SUBMITTAL  
DATE: OCTOBER 5, 2020 ORB #: 19-209

**A3.63C**  
BUILDING #15 - COLOR EXTERIOR  
ELEVATIONS

MATERIAL AND COLOR KEY

A	STUCCO LIGHT YELLOW LRV 50
B	STUCCO LIGHT BROWN LRV 42
C	STUCCO DARK BROWN LRV 27
D	GARAGE DOOR PAINTED DARK BROWN LRV 27
E	STUCCO LIGHT RED LRV 20
F	METAL RAILINGS COLOR WHITE
G	VINYL WINDOWS COLOR WHITE
H	GREY METAL ROOF LRV TO BE BETWEEN 20 & 50
I	METAL FASCIA COLOR WHITE

**ALLASO  
HIGH DESERT**  
SWC TENNYSON STREET AND SAN ANTONIO DR.  
ALBUQUERQUE, NEW MEXICO

Office of Rich Barber  
**ORB**  
Architecture  
WorldHQ@ORBArch.com

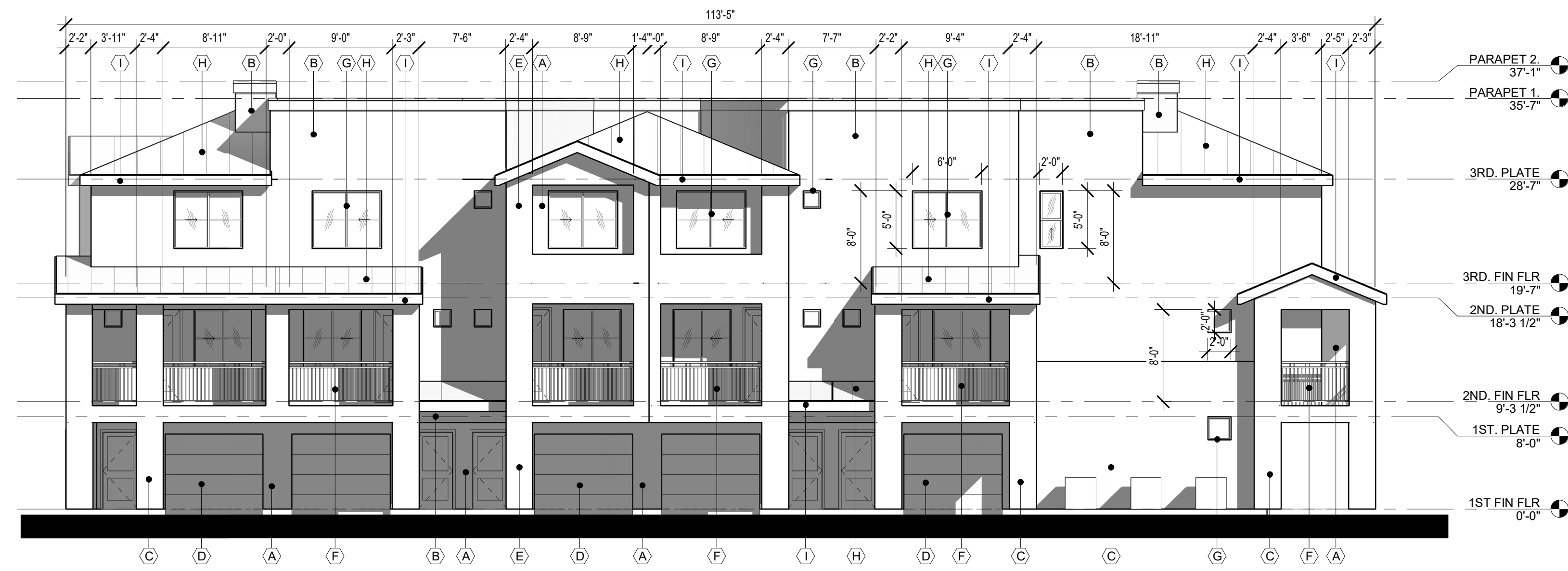

1 BLDG #16 - FRONT ELEVATION  
SCALE: 1/8" = 1'-0"

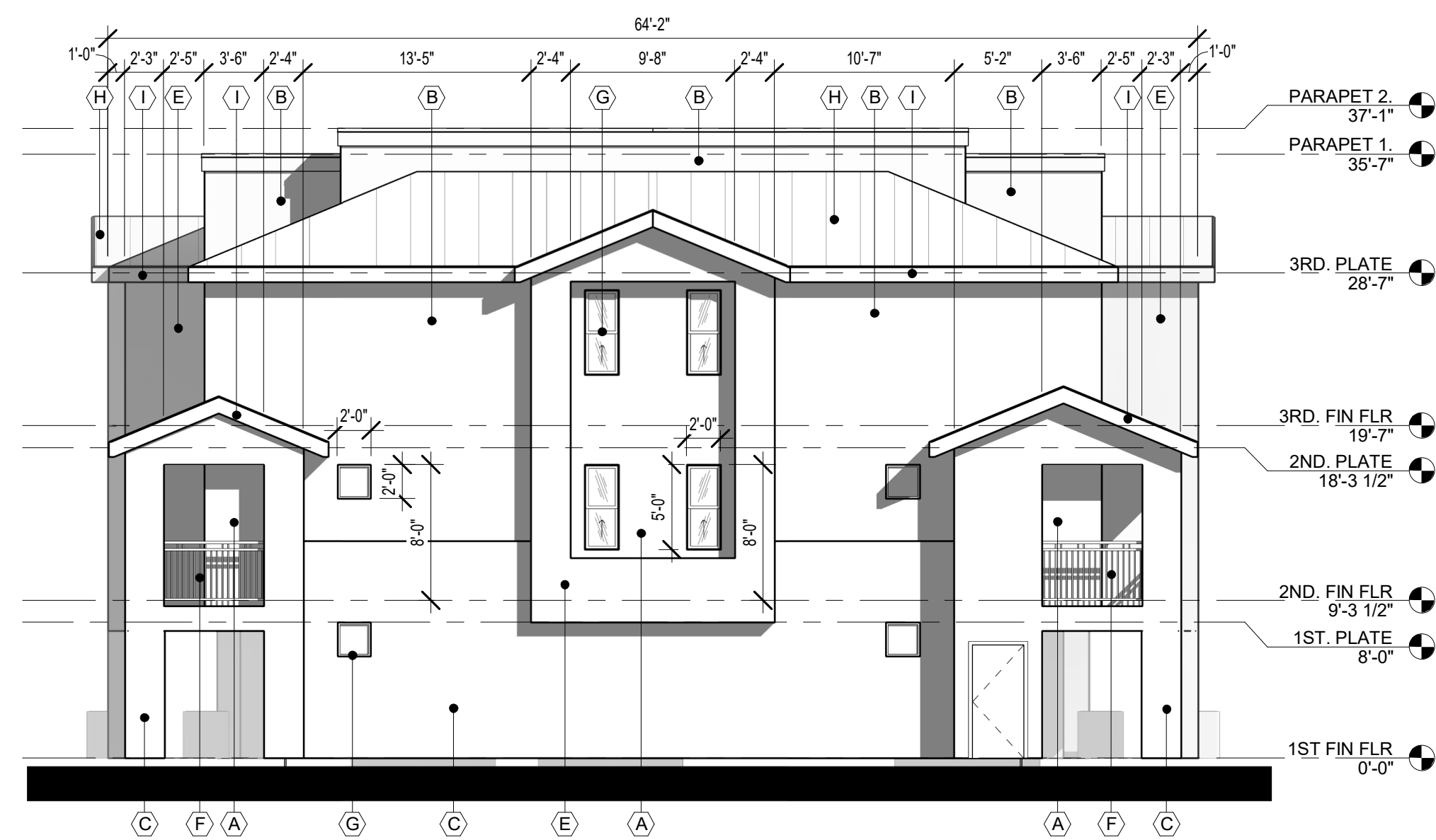

3 BLDG #16 - LEFT ELEVATION  
SCALE: 1/8" = 1'-0"

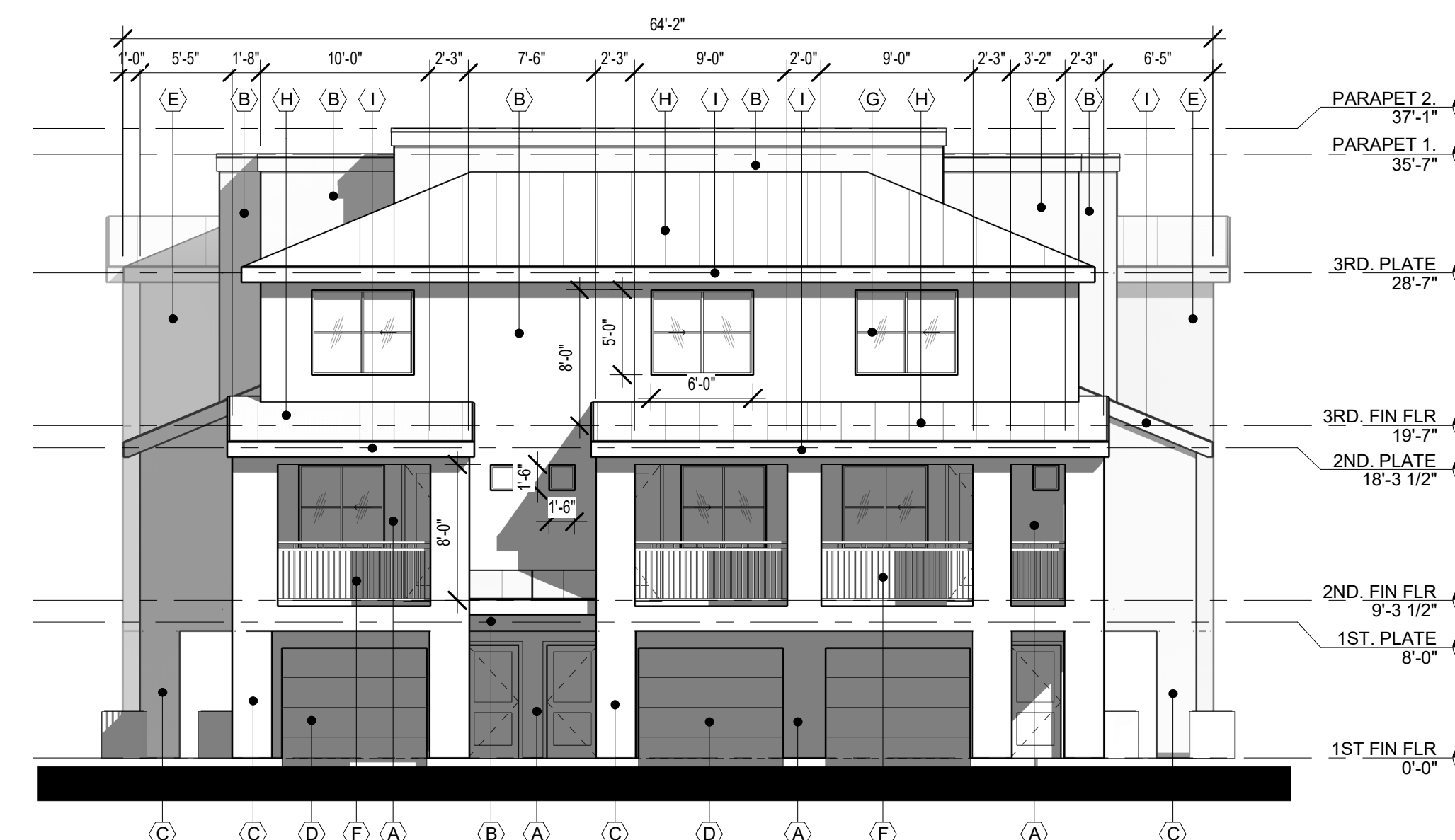

2 BLDG #16 - RIGHT ELEVATION  
SCALE: 1/8" = 1'-0"

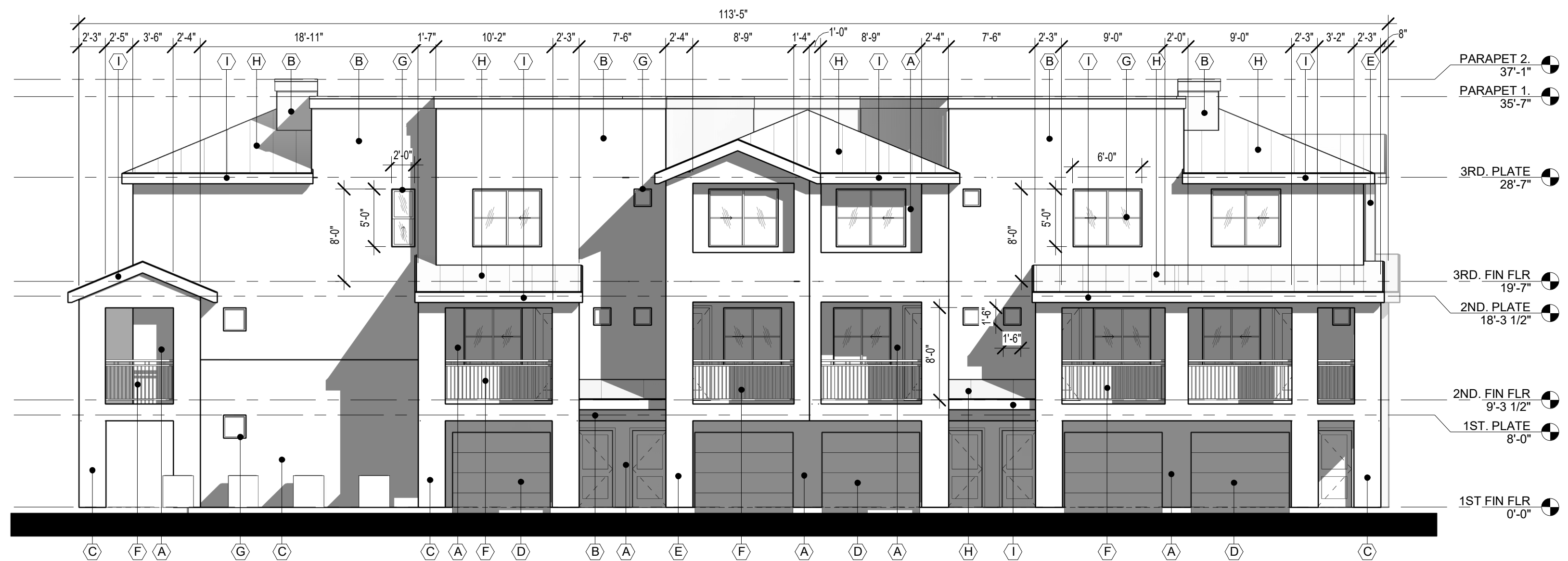

4 BLDG #16 - REAR ELEVATION  
SCALE: 1/8" = 1'-0"

DRB SUBMITTAL  
DATE: OCTOBER 5, 2020 ORB #: 19-209

**A3.73**  
BUILDING #16 - EXTERIOR  
ELEVATIONS

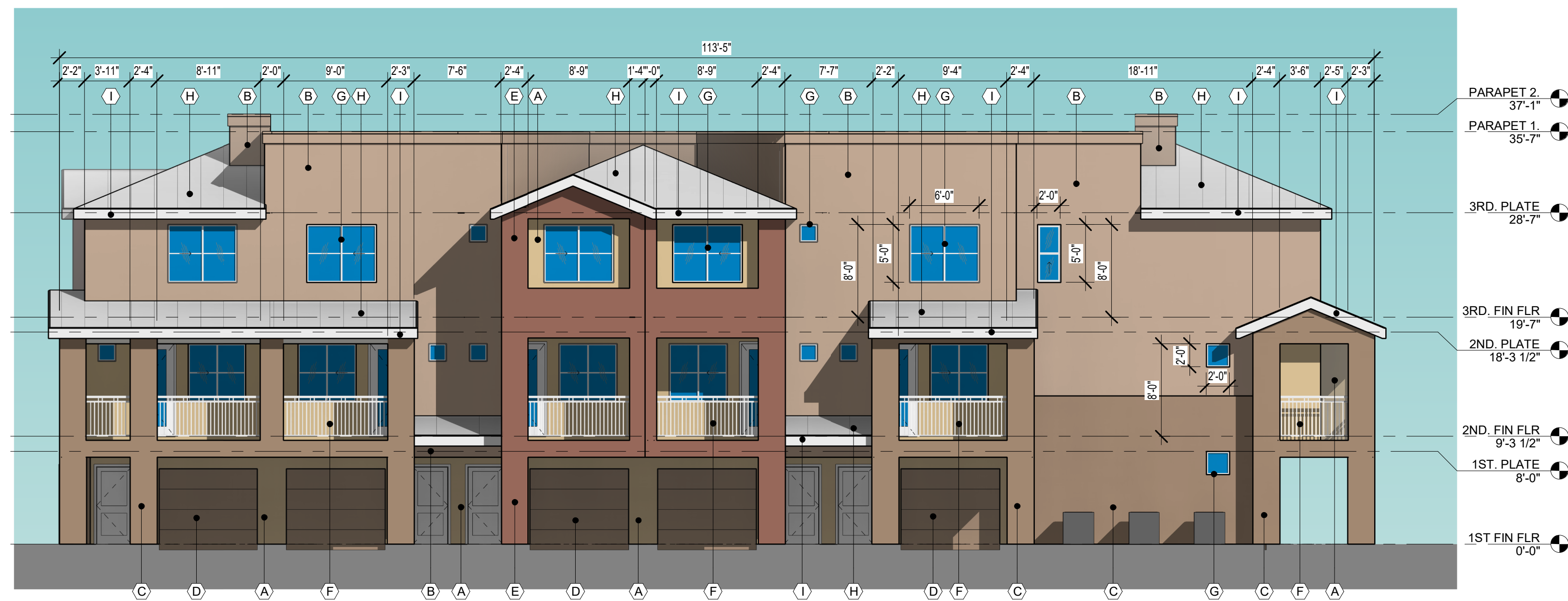

1 BLDG #16 - FRONT ELEVATION  
SCALE: 1/8" = 1'-0"

**MATERIAL AND COLOR KEY**

A	STUCCO LIGHT YELLOW LRV 50
B	STUCCO LIGHT BROWN LRV 42
C	STUCCO DARK BROWN LRV 27
D	GARAGE DOOR PAINTED DARK BROWN LRV 27
E	STUCCO LIGHT RED LRV 20
F	METAL RAILINGS COLOR WHITE
G	VINYL WINDOWS COLOR WHITE
H	GREY METAL ROOF LRV TO BE BETWEEN 20 & 50
I	METAL FASCIA COLOR WHITE

**ALLASO HIGH DESERT**  
 SWC TENNYSON STREET AND SAN ANTONIO DR.  
 ALBUQUERQUE, NEW MEXICO

Office of Rich Barber  
**ORB** Architecture  
 WorldHQ@ORBArch.com

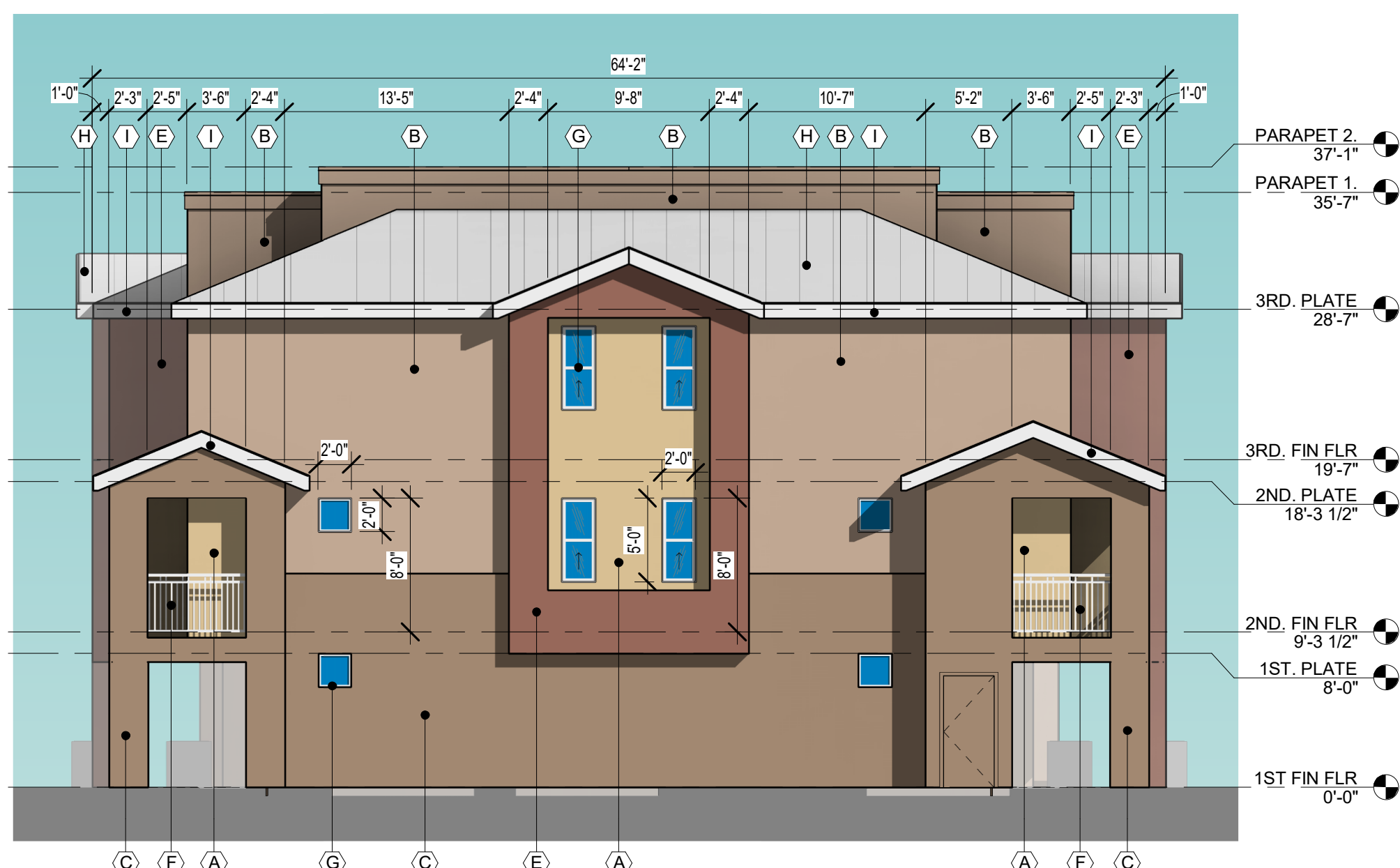

3 BLDG #16 - LEFT ELEVATION  
SCALE: 1/8" = 1'-0"

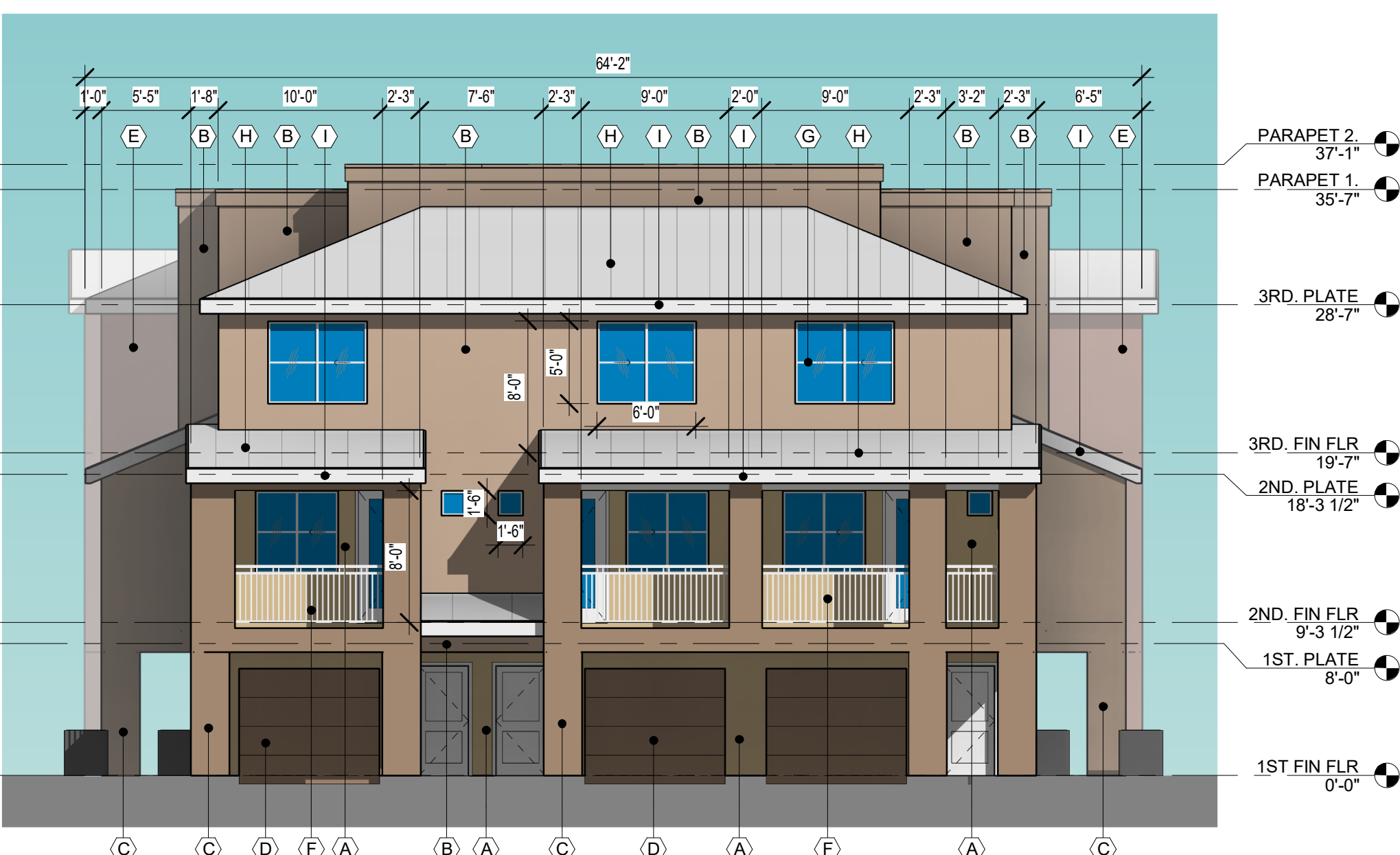

2 BLDG #16 - RIGHT ELEVATION  
SCALE: 1/8" = 1'-0"

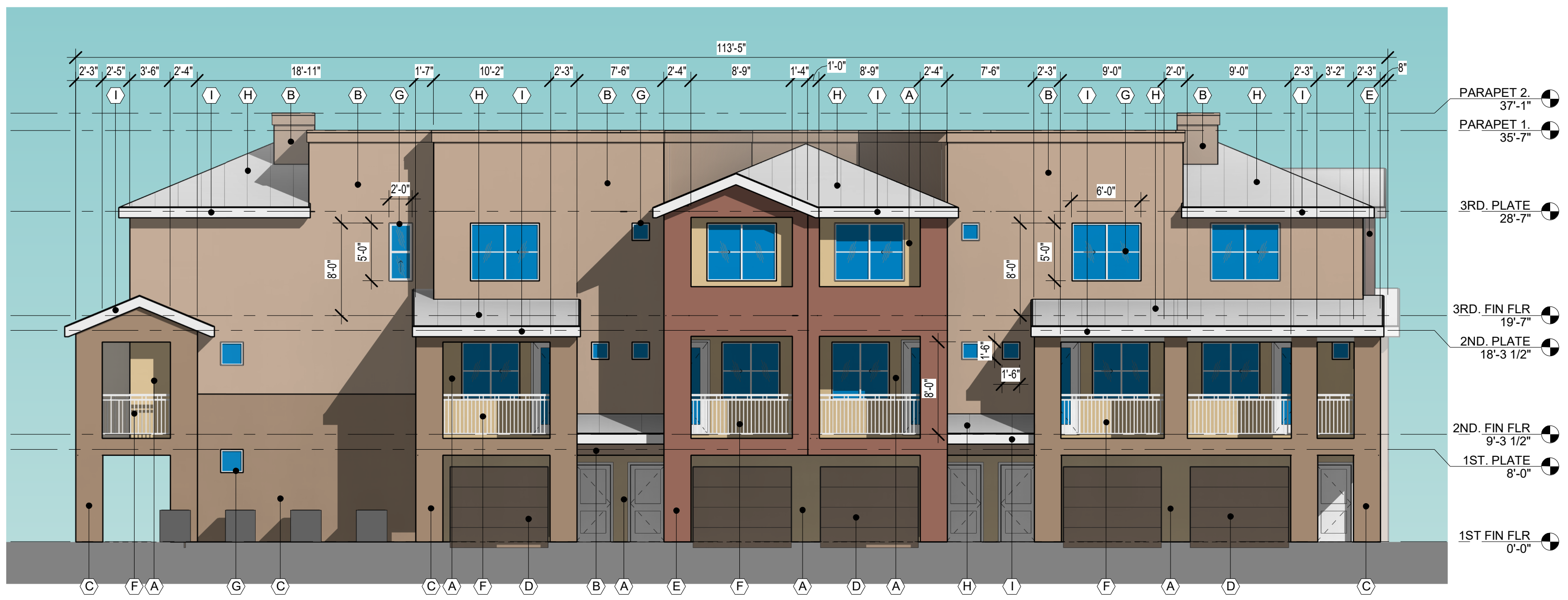

4 BLDG #16 - REAR ELEVATION  
SCALE: 1/8" = 1'-0"

DRB SUBMITTAL  
 DATE: OCTOBER 5, 2020 ORB #: 19-209

**A3.73C**  
 BUILDING #16 - COLOR EXTERIOR ELEVATIONS

MATERIAL AND COLOR KEY

A	STUCCO LIGHT YELLOW LRV 50
B	STUCCO LIGHT BROWN LRV 42
C	STUCCO DARK BROWN LRV 27
D	GARAGE DOOR PAINTED DARK BROWN LRV 27
E	STUCCO LIGHT RED LRV 20
F	METAL RAILINGS COLOR WHITE
G	VINYL WINDOWS COLOR WHITE
H	GREY METAL ROOF LRV TO BE BETWEEN 20 & 50
I	METAL FASCIA COLOR WHITE

**ALLASO  
HIGH DESERT**  
SWC TENNYSON STREET AND SAN ANTONIO DR.  
ALBUQUERQUE, NEW MEXICO

Office of Rich Barber  
**ORB**  
Architecture  
WorldHQ@ORBArch.com



**TITAN**  
DEVELOPMENT

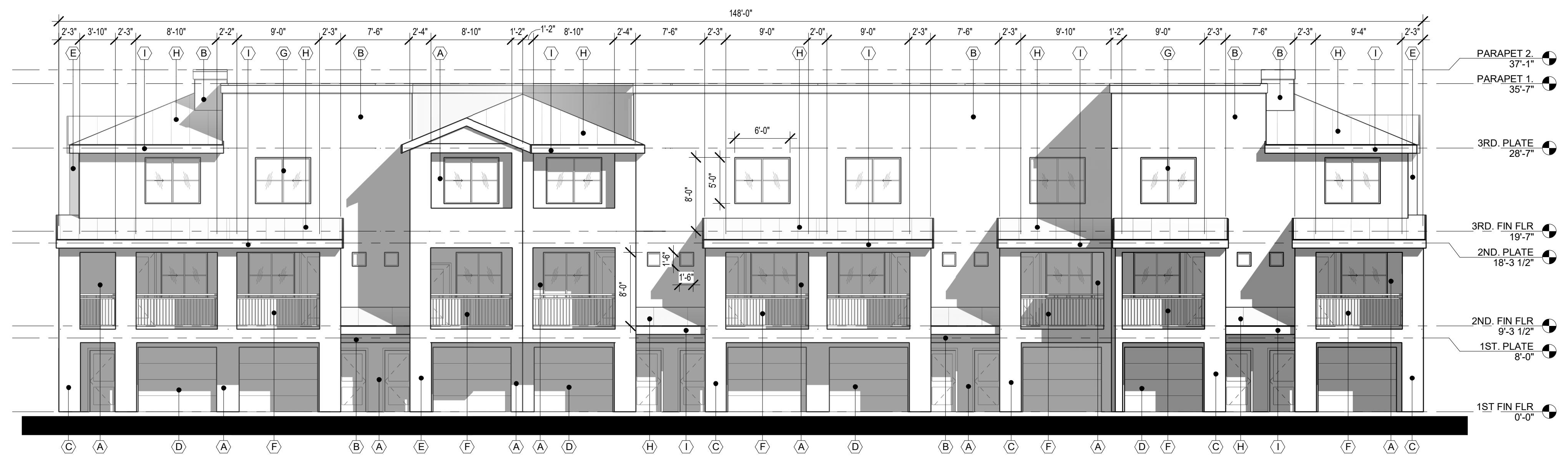

**1 BLDG #18 - FRONT ELEVATION**  
SCALE: 1/8" = 1'-0"

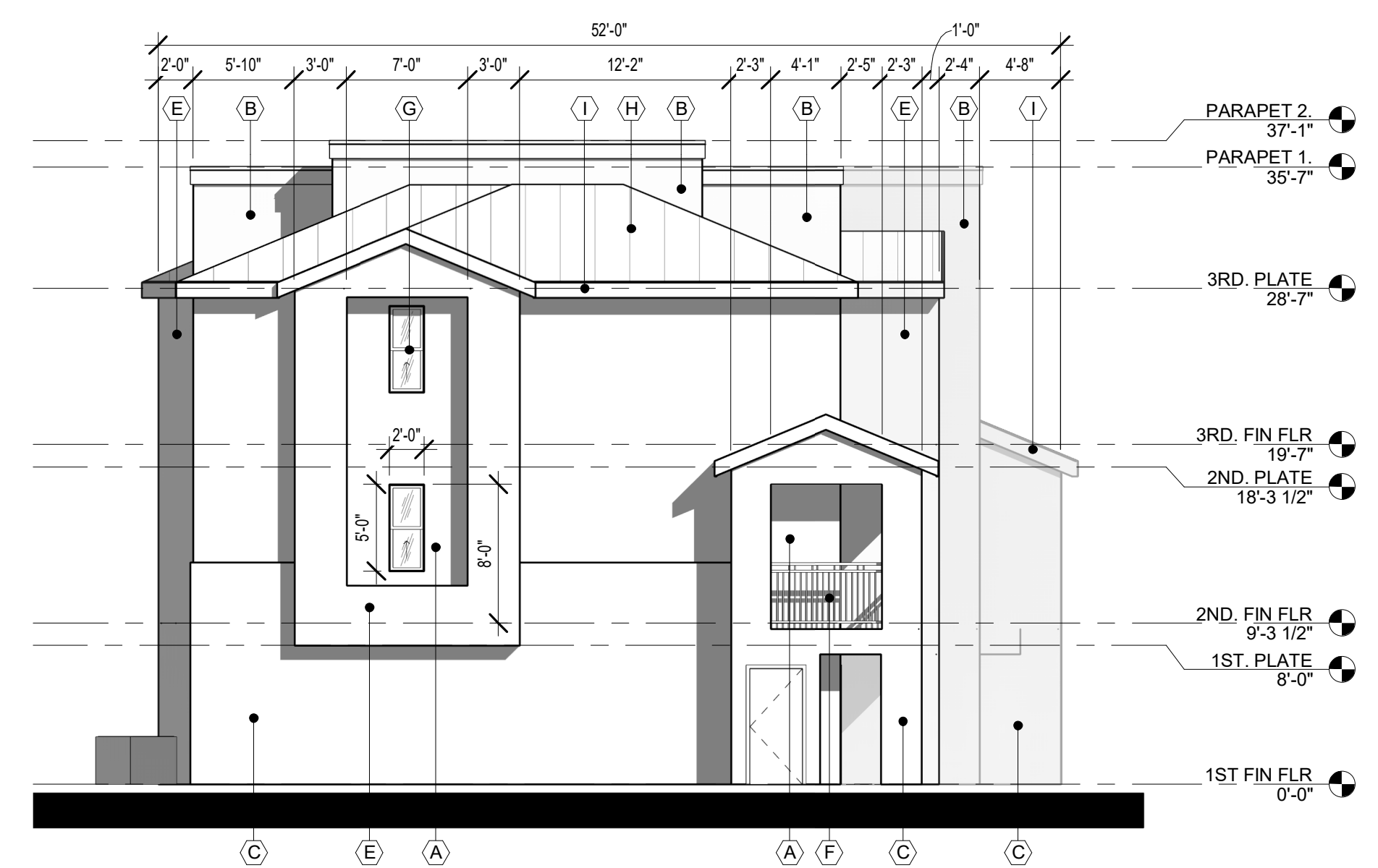

**3 BLDG #18 - LEFT ELEVATION**  
SCALE: 1/8" = 1'-0"

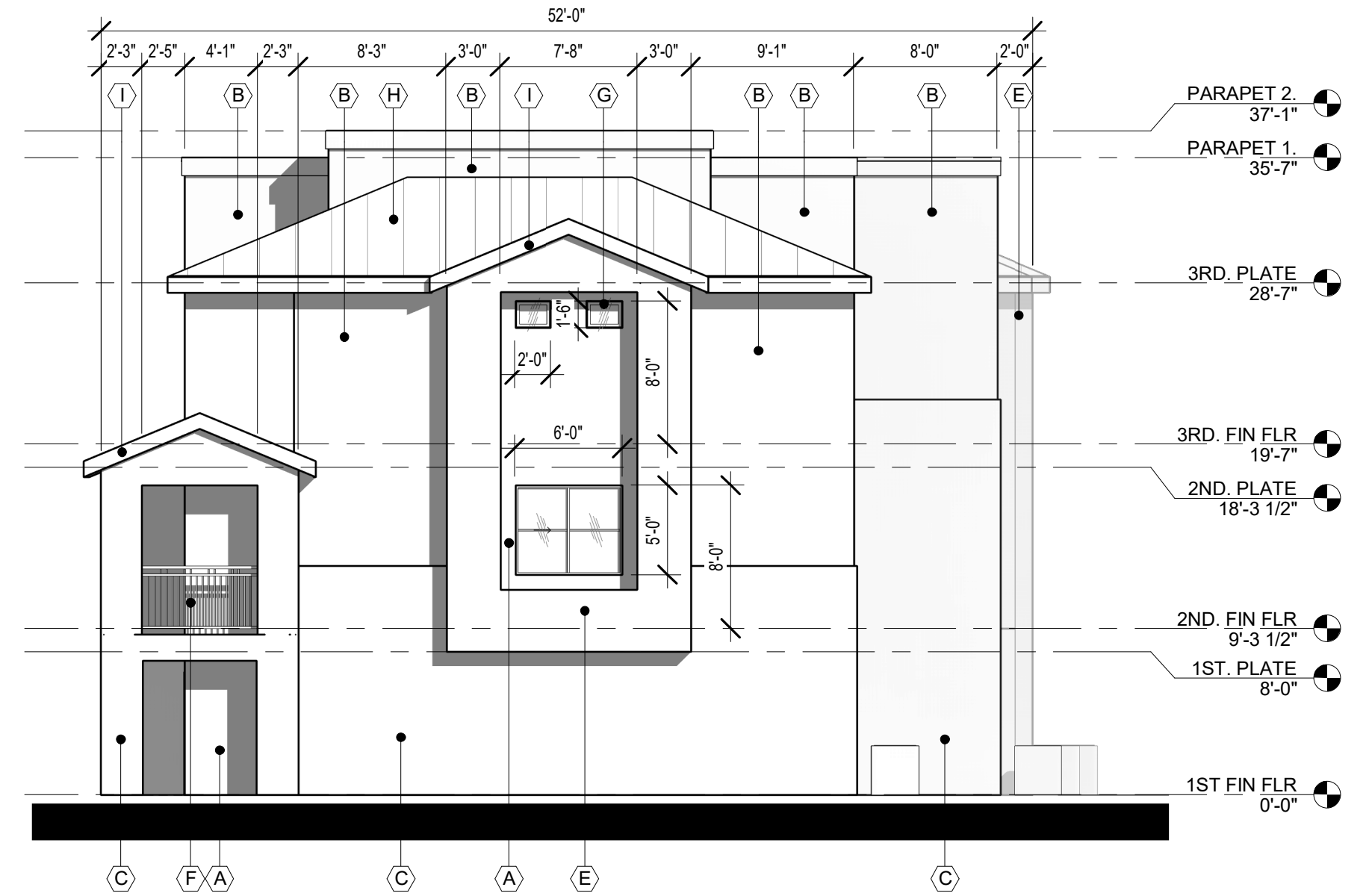

**2 BLDG #18 - RIGHT ELEVATION**  
SCALE: 1/8" = 1'-0"

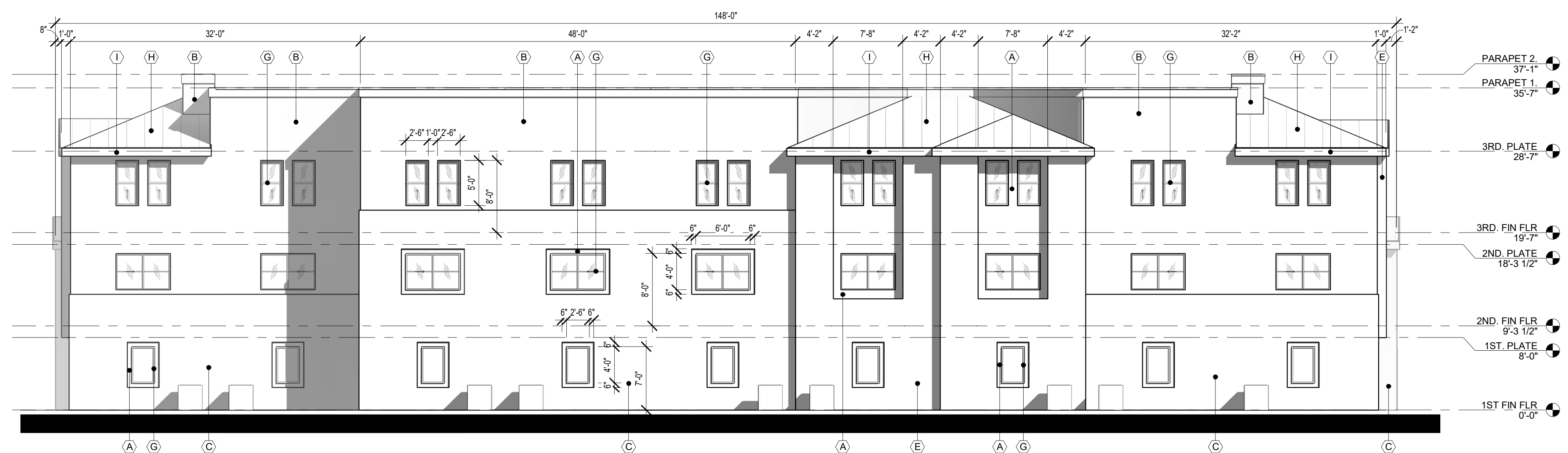

**4 BLDG #18 - REAR ELEVATION**  
SCALE: 1/8" = 1'-0"

DRB SUBMITTAL  
DATE: OCTOBER 5, 2020 DRB #: 19-209

**A3.83**  
BUILDING #18 - EXTERIOR  
ELEVATIONS

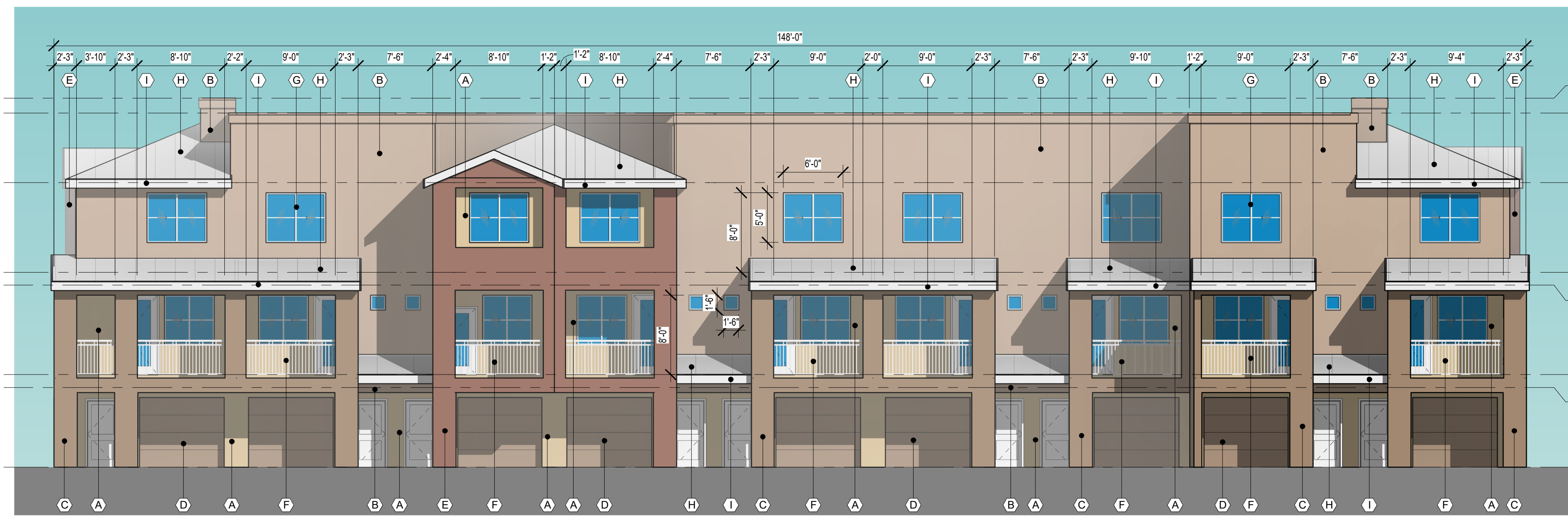

MATERIAL AND COLOR KEY

A	STUCCO LIGHT YELLOW LRV 50
B	STUCCO LIGHT BROWN LRV 42
C	STUCCO DARK BROWN LRV 27
D	GARAGE DOOR PAINTED DARK BROWN LRV 27
E	STUCCO LIGHT RED LRV 20
F	METAL RAILINGS COLOR WHITE
G	VINYL WINDOWS COLOR WHITE
H	GREY METAL ROOF LRV TO BE BETWEEN 20 & 50
I	METAL FASCIA COLOR WHITE

**ALLASO  
HIGH DESERT**  
SWC TENNYSON STREET AND SAN ANTONIO DR.  
ALBUQUERQUE, NEW MEXICO

Office of Rich Barber  
**ORB**  
Architecture  
WorldHQ@ORBArch.com



**TITAN**  
DEVELOPMENT

1 BLDG #18 - FRONT ELEVATION  
SCALE: 1/8" = 1'-0"

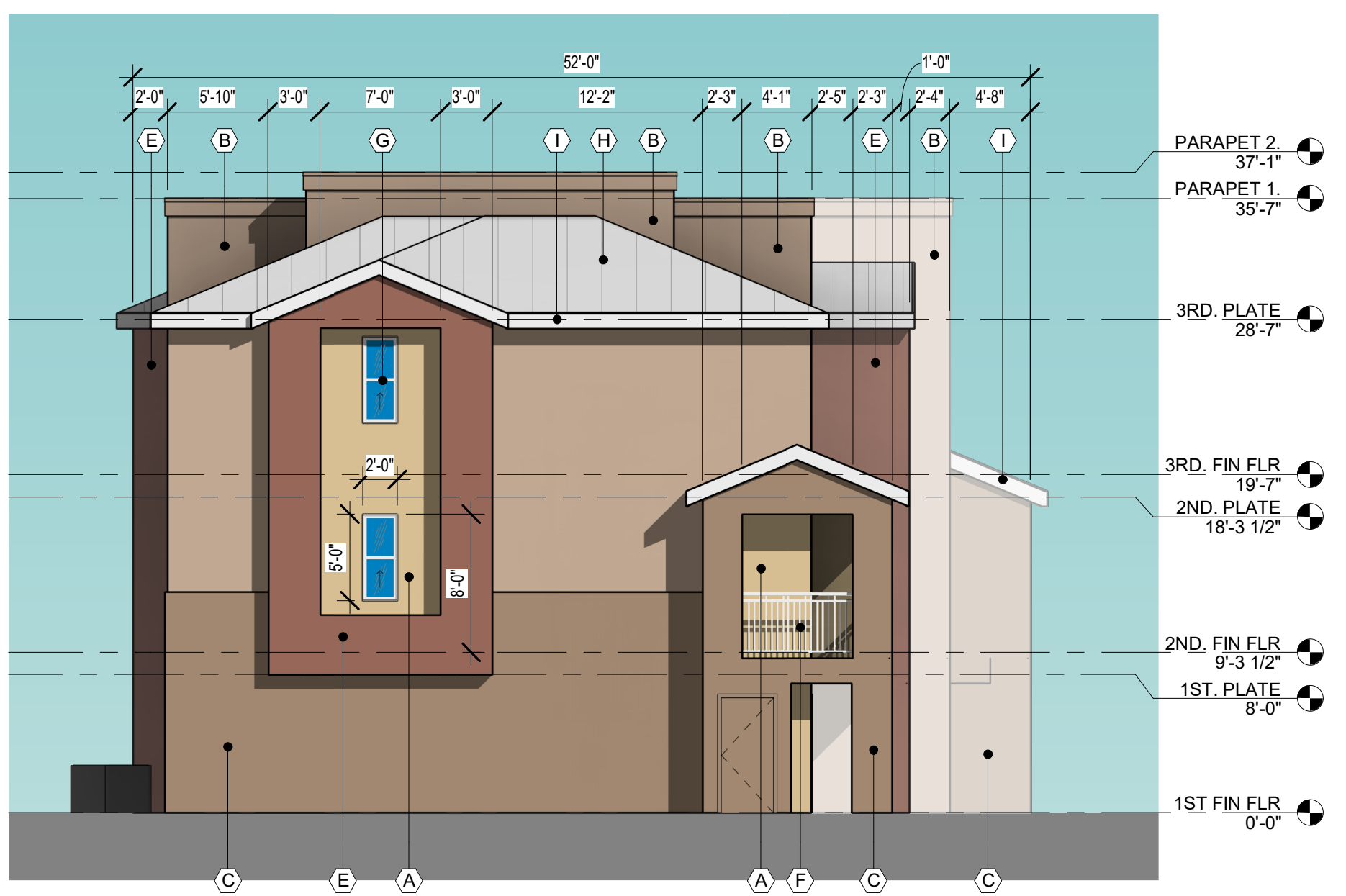

3 BLDG #18 - LEFT ELEVATION  
SCALE: 1/8" = 1'-0"

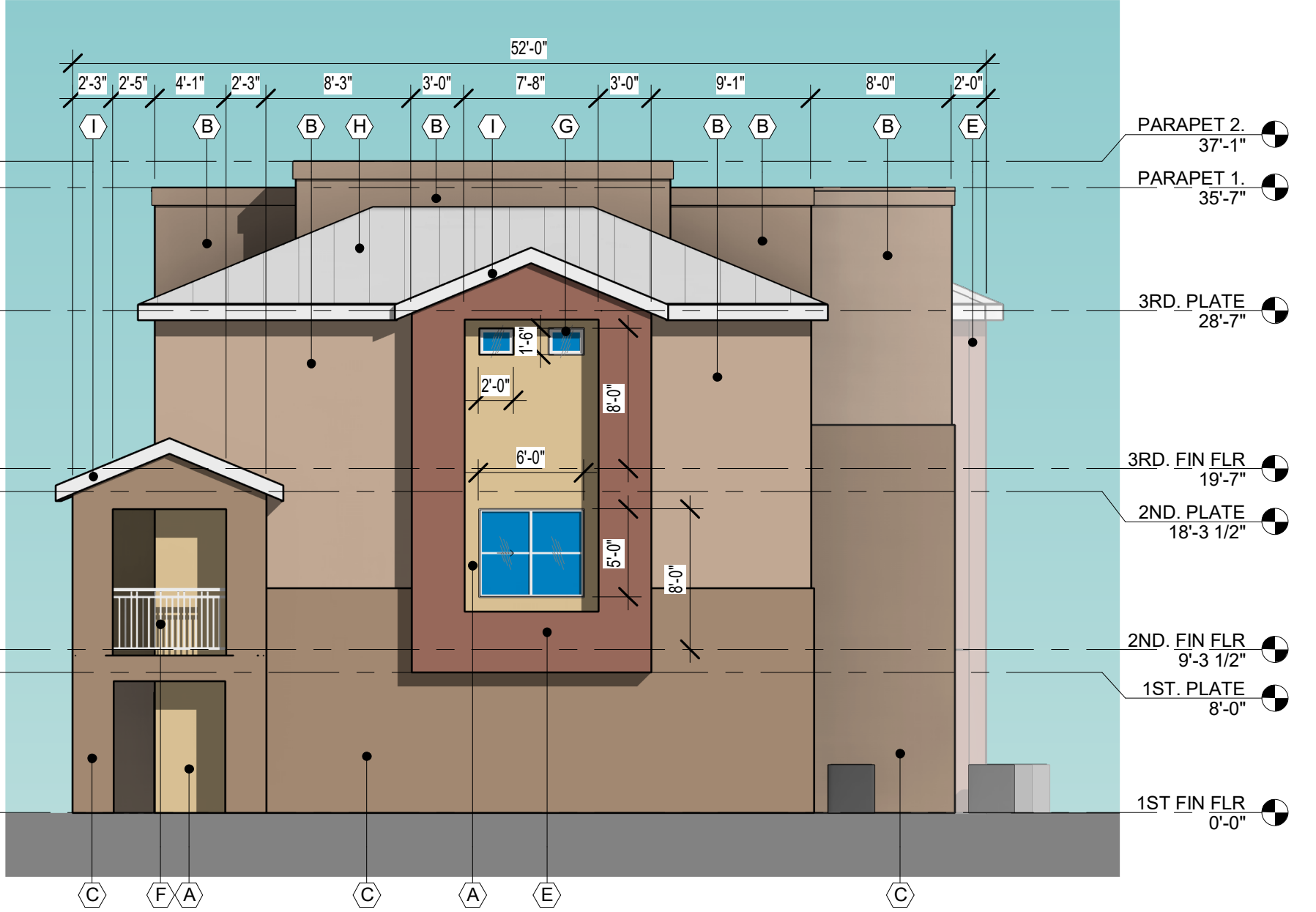

2 BLDG #18 - RIGHT ELEVATION  
SCALE: 1/8" = 1'-0"

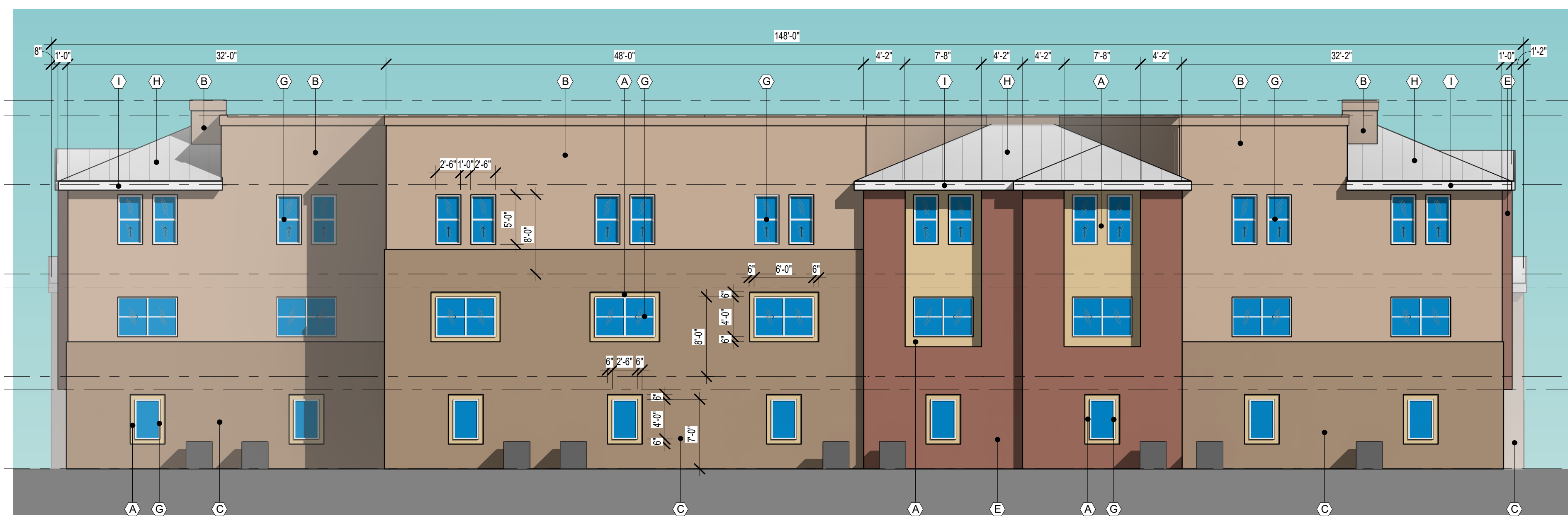

4 BLDG #18 - REAR ELEVATION  
SCALE: 1/8" = 1'-0"

DRB SUBMITTAL  
DATE: OCTOBER 5, 2020 DRB #: 19-209

**A3.83C**  
BUILDING #18 - COLOR EXTERIOR  
ELEVATIONS

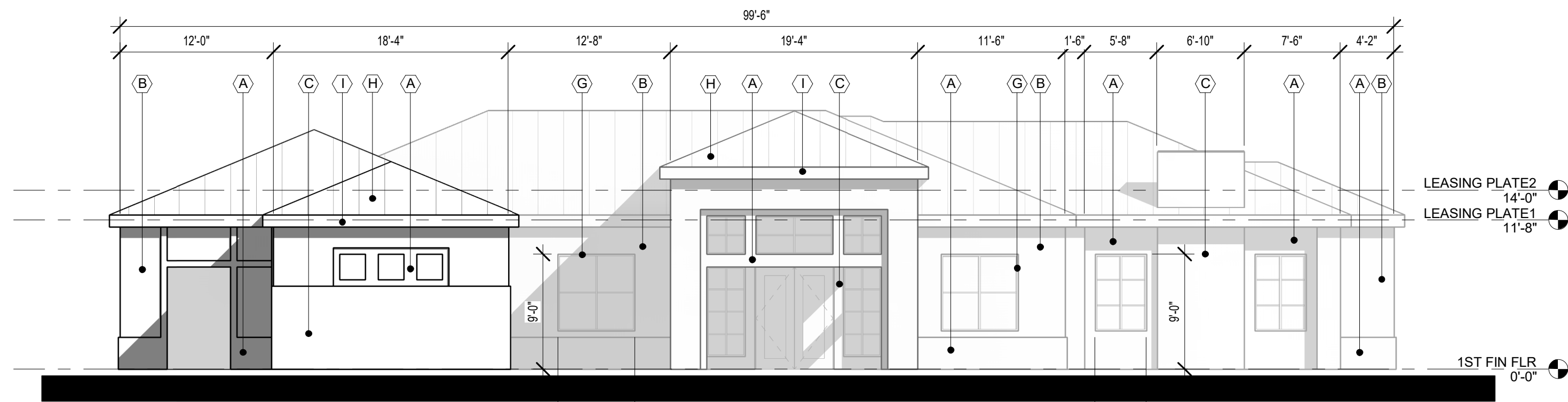

1 LEASING - FRONT ELEVATION  
SCALE: 1/8" = 1'-0"

**MATERIAL AND COLOR KEY**

A	STUCCO LIGHT YELLOW LRV 50
B	STUCCO LIGHT BROWN LRV 42
C	STUCCO DARK BROWN LRV 27
D	GARAGE DOOR PAINTED DARK BROWN LRV 27
E	STUCCO LIGHT RED LRV 20
F	METAL RAILINGS COLOR WHITE
G	VINYL WINDOWS COLOR WHITE
H	GREY METAL ROOF LRV TO BE BETWEEN 20 & 50
I	METAL FASCIA COLOR WHITE

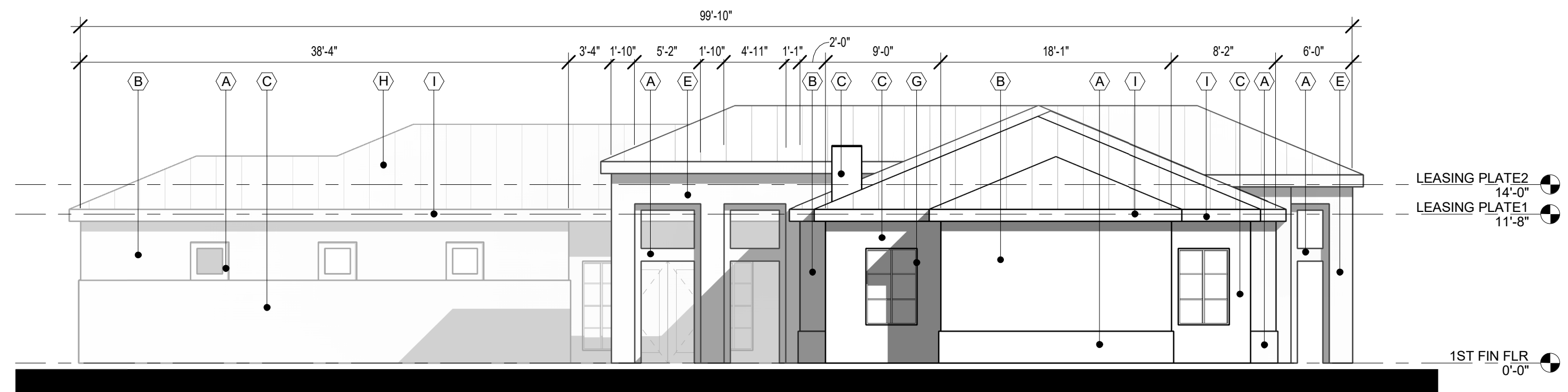

2 LEASING - RIGHT ELEVATION  
SCALE: 1/8" = 1'-0"

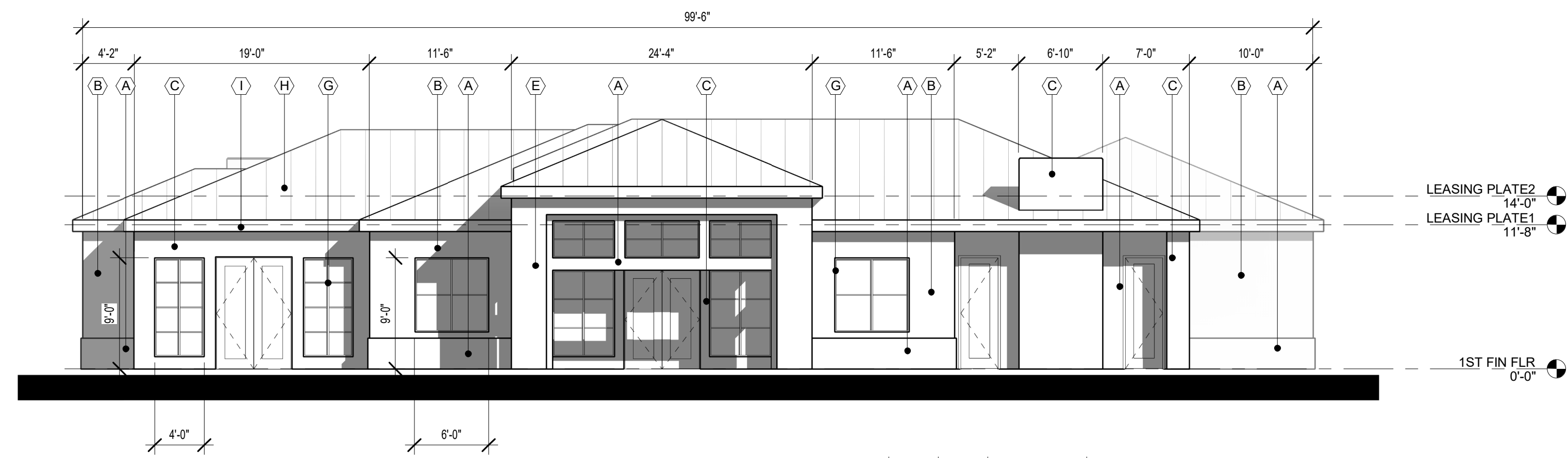

3 LEASING - REAR ELEVATION  
SCALE: 1/8" = 1'-0"

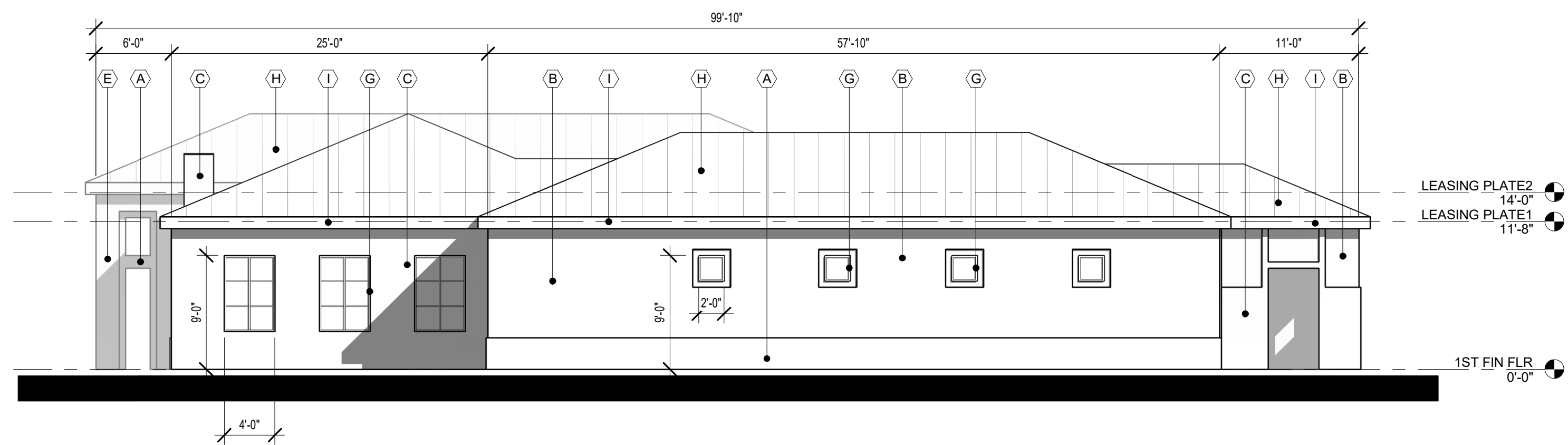

4 LEASING - LEFT ELEVATION  
SCALE: 1/8" = 1'-0"

**ALLASO  
HIGH DESERT**  
SWC TENNYSON STREET AND SAN ANTONIO DR.  
**ALBUQUERQUE, NEW MEXICO**

Office of Rich Barber  
**ORB**  
Architecture  
WorldHQ@ORBArch.com



**TITAN**  
DEVELOPMENT

DRB SUBMITTAL  
DATE: OCTOBER 5, 2020 ORB #: 19-209

**A5.13**  
BUILDING LEASING - EXTERIOR  
ELEVATIONS

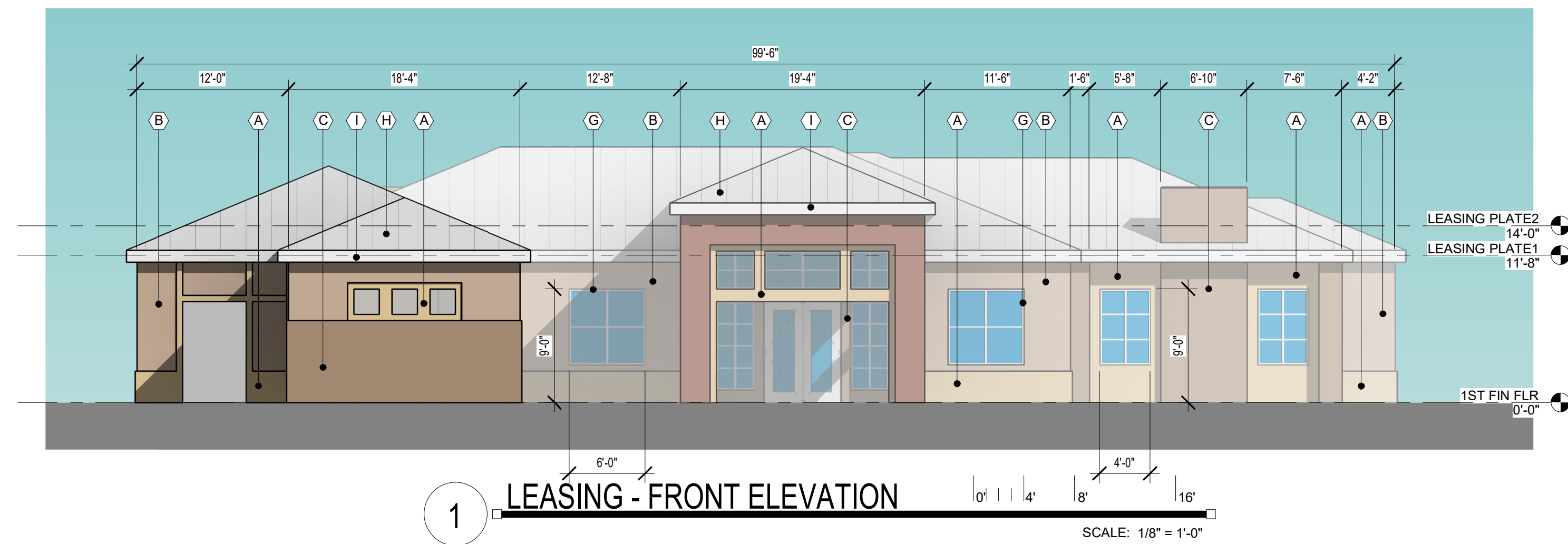

1 LEASING - FRONT ELEVATION  
SCALE: 1/8" = 1'-0"

**MATERIAL AND COLOR KEY**

A	STUCCO LIGHT YELLOW LRV 50
B	STUCCO LIGHT BROWN LRV 42
C	STUCCO DARK BROWN LRV 27
D	GARAGE DOOR PAINTED DARK BROWN LRV 27
E	STUCCO LIGHT RED LRV 20
F	METAL RAILINGS COLOR WHITE
G	VINYL WINDOWS COLOR WHITE
H	GREY METAL ROOF LRV TO BE BETWEEN 20 & 50
I	METAL FASCIA COLOR WHITE

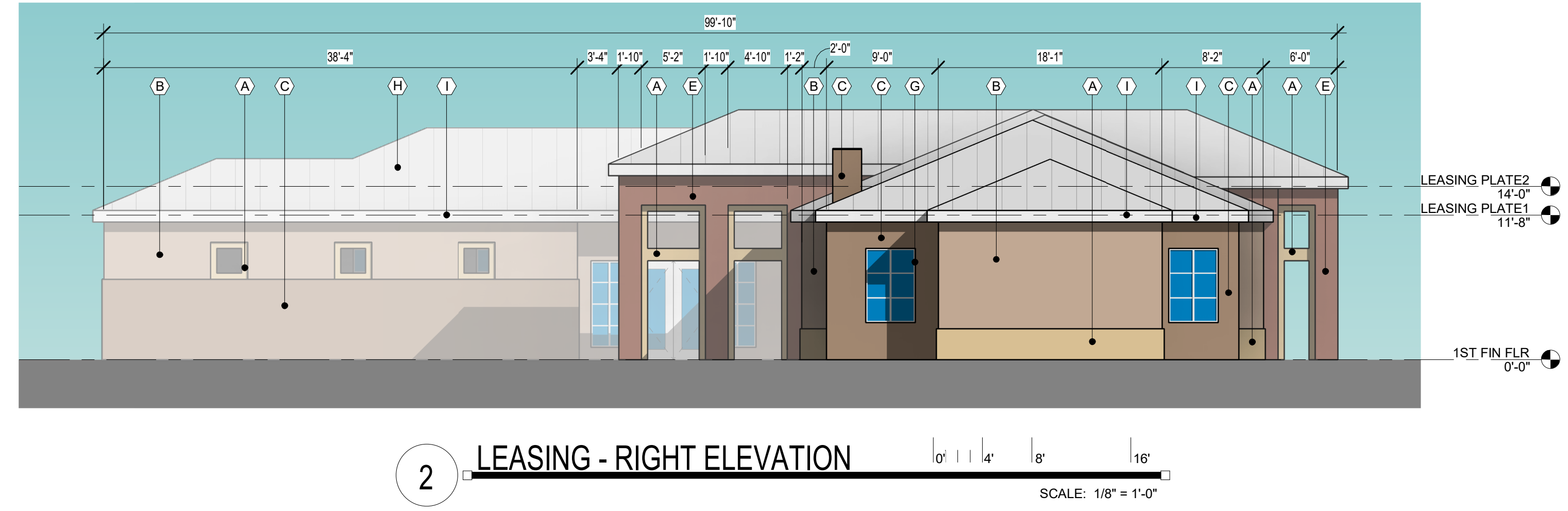

2 LEASING - RIGHT ELEVATION  
SCALE: 1/8" = 1'-0"

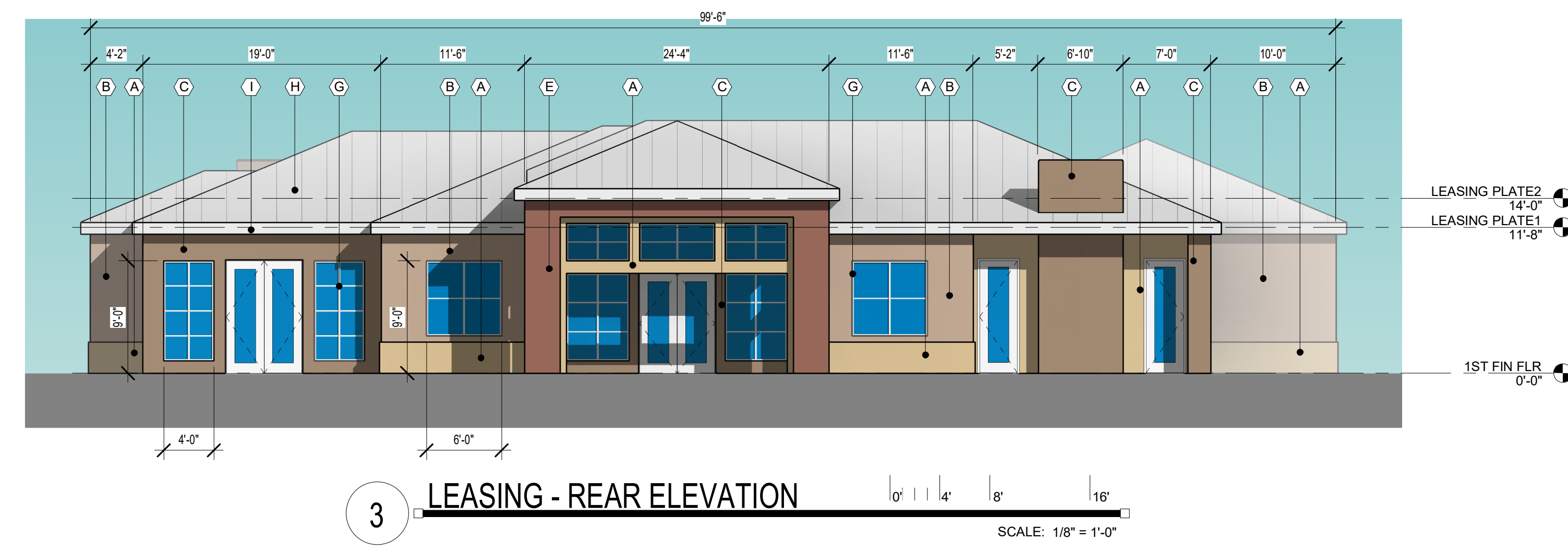

3 LEASING - REAR ELEVATION  
SCALE: 1/8" = 1'-0"

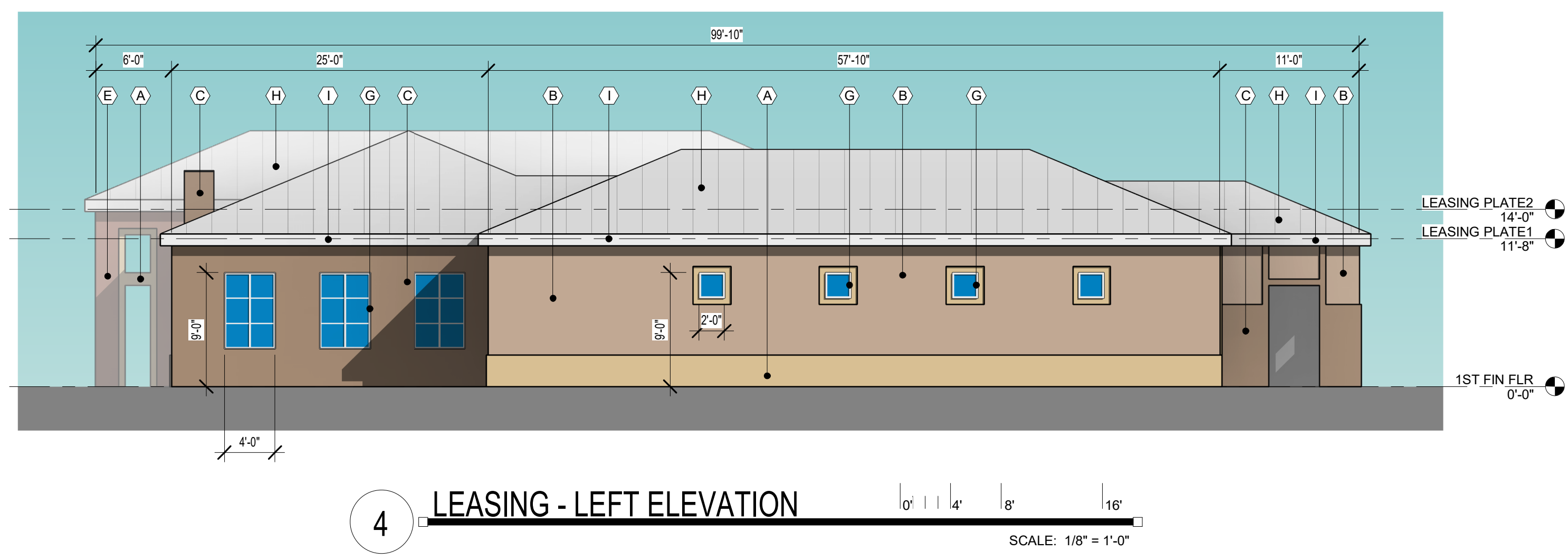

4 LEASING - LEFT ELEVATION  
SCALE: 1/8" = 1'-0"

**ALLASO  
HIGH DESERT**  
SWC TENNYSON STREET AND SAN ANTONIO DR.  
ALBUQUERQUE, NEW MEXICO

Office of Rich Barber  
**ORB**  
Architecture  
WorldHQ@ORBArch.com



**TITAN**  
DEVELOPMENT

DRB SUBMITTAL  
DATE: OCTOBER 5, 2020 ORB #: 19-209

**A5.13C**  
BUILDING LEASING - COLOR  
EXTERIOR ELEVATIONS

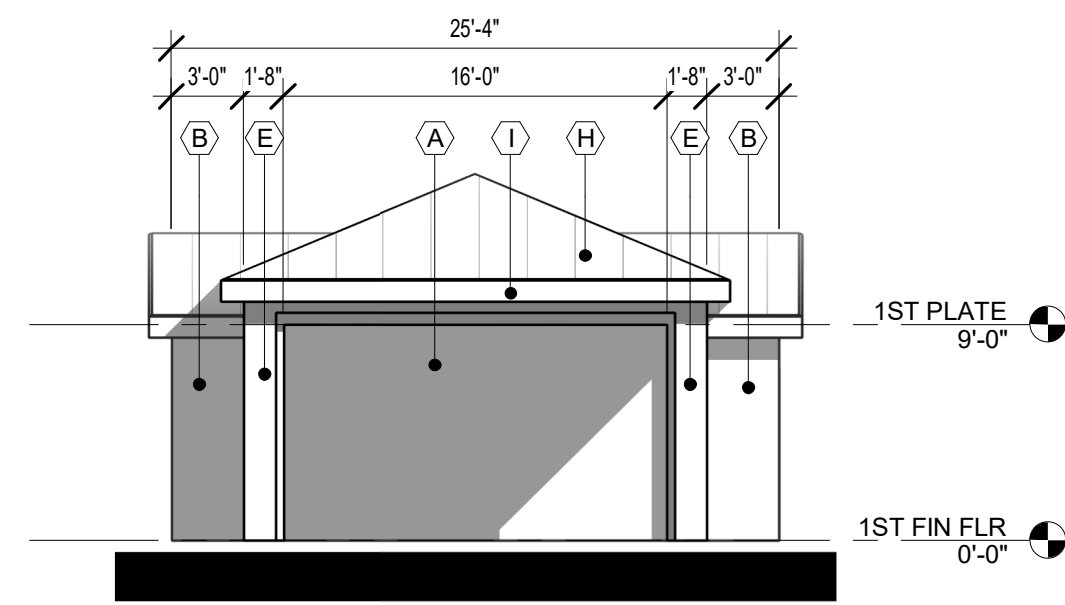

5 EXTERIOR ELEVATIONS  
SCALE: 1/8" = 1'-0"

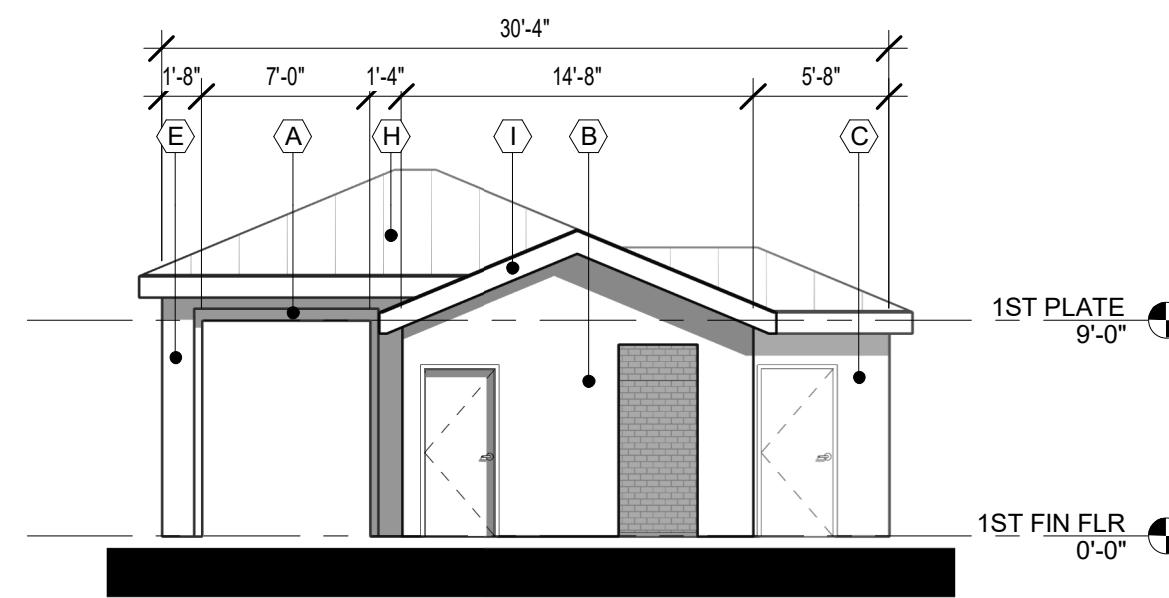

6 POOL EQUIP. - RIGHT ELEVATION  
SCALE: 1/8" = 1'-0"

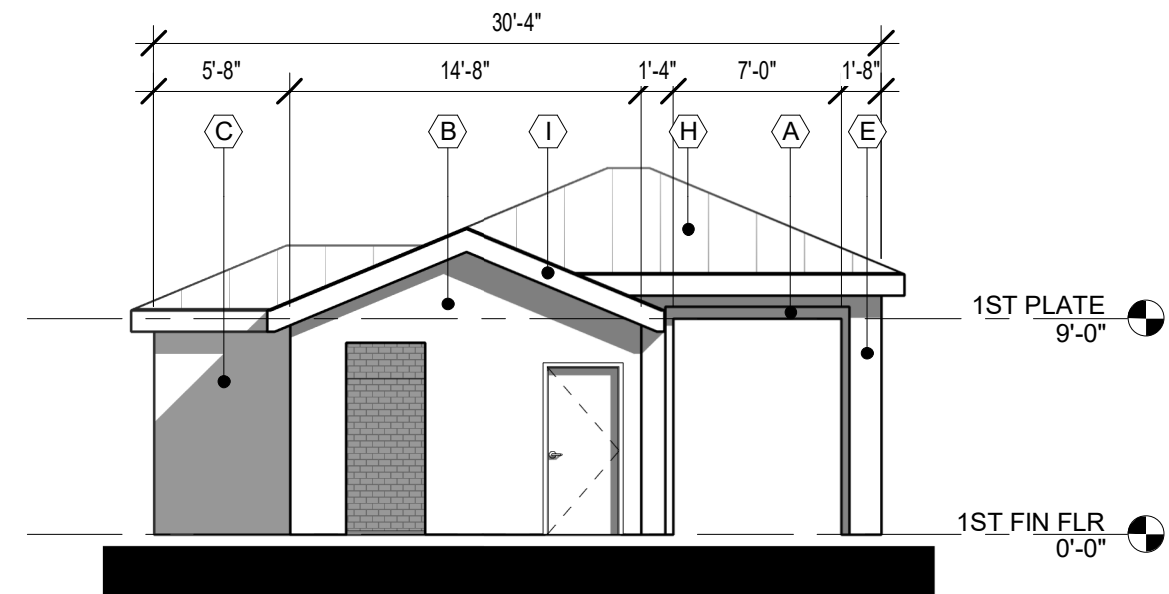

7 POOL EQUIP. - LEFT ELEVATION  
SCALE: 1/8" = 1'-0"

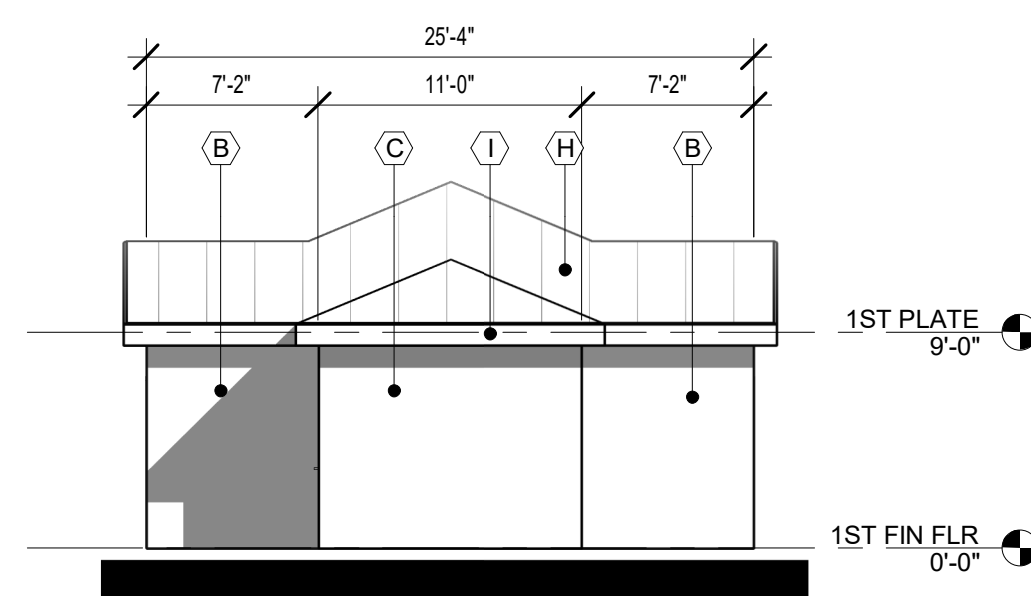

8 POOL EQUIP. - REAR ELEVATION  
SCALE: 1/8" = 1'-0"

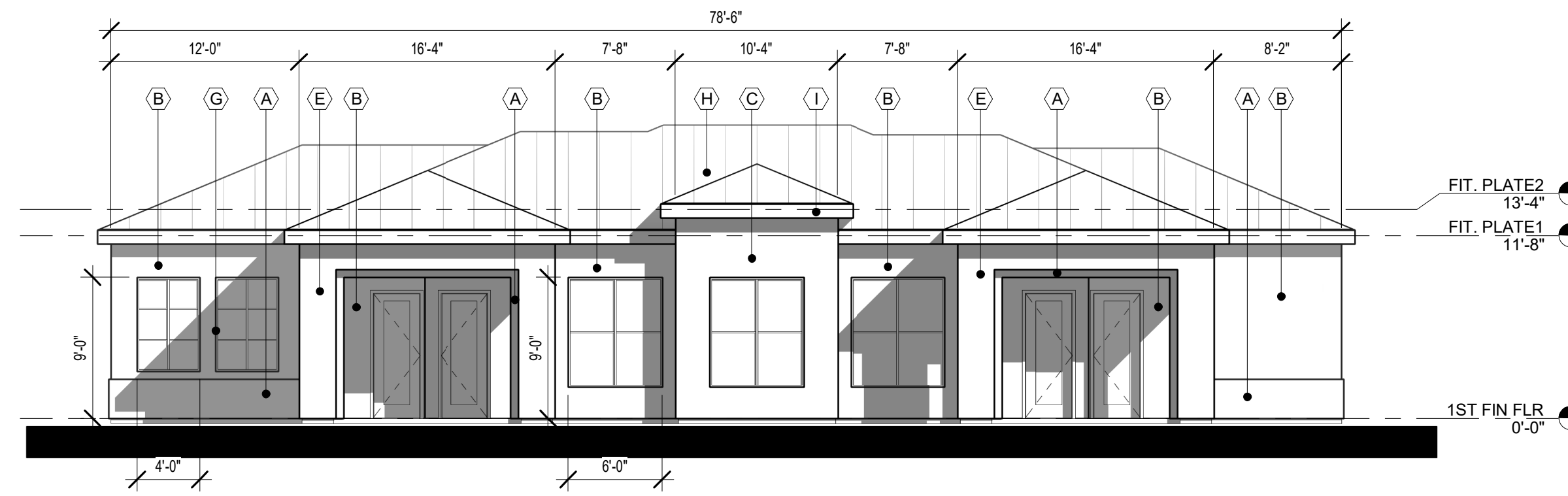

1 EXERCISE - FRONT ELEVATION  
SCALE: 1/8" = 1'-0"

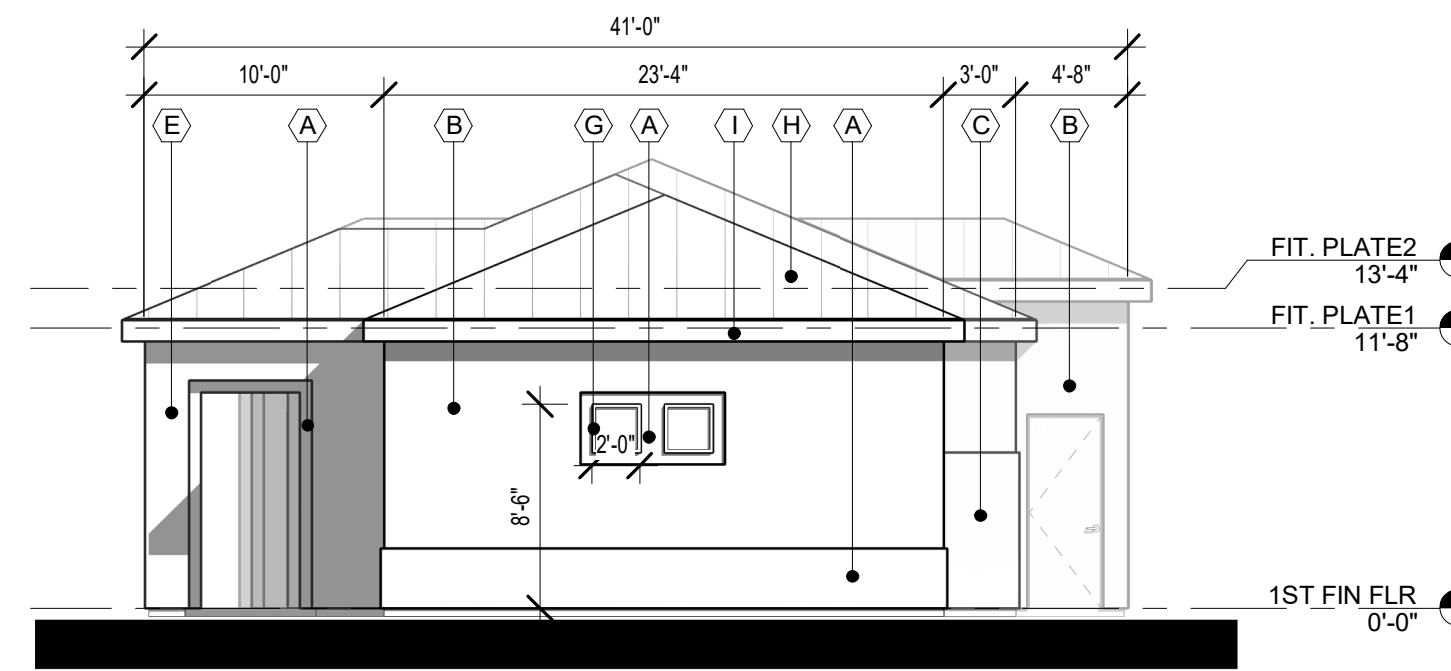

2 EXERCISE - RIGHT ELEVATION  
SCALE: 1/8" = 1'-0"

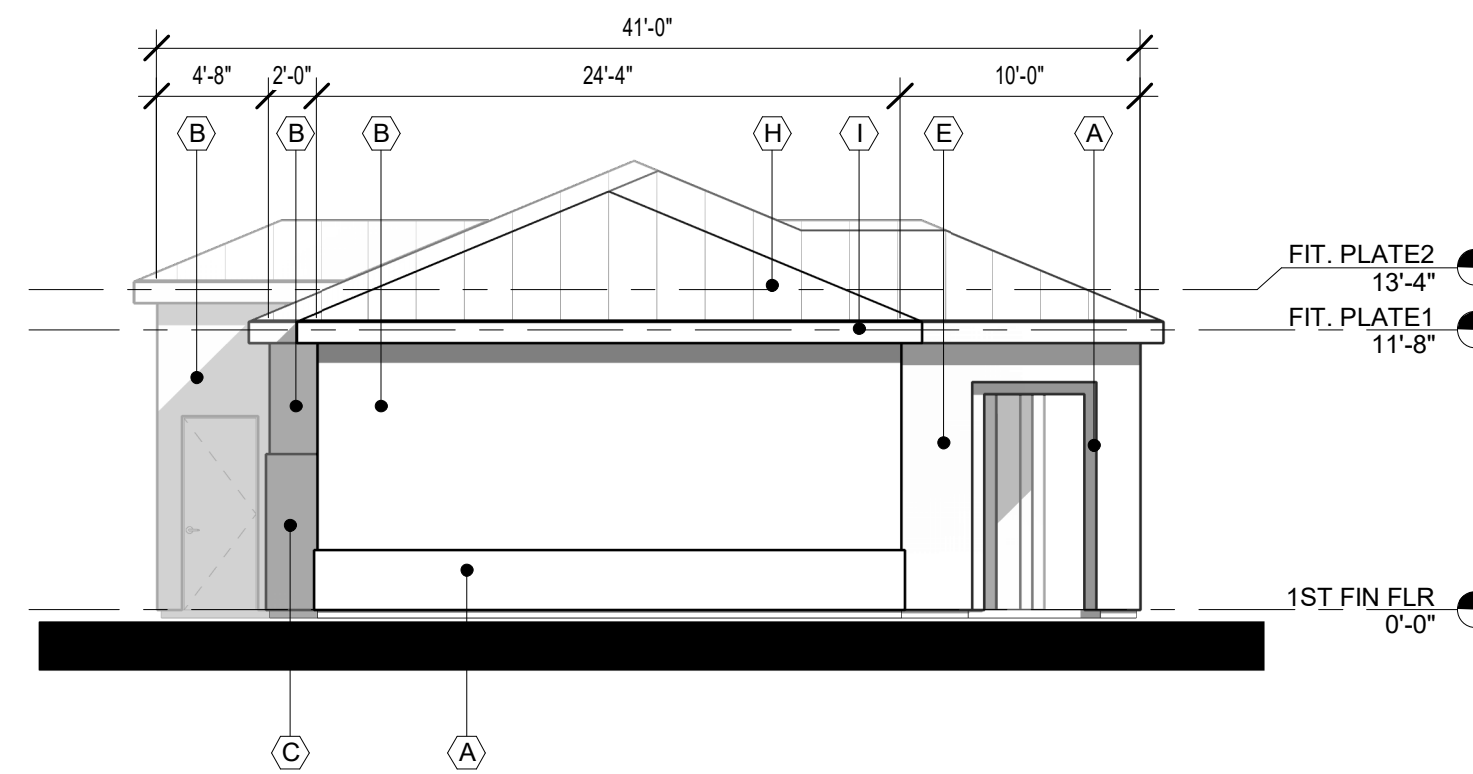

3 EXERCISE - LEFT ELEVATION  
SCALE: 1/8" = 1'-0"

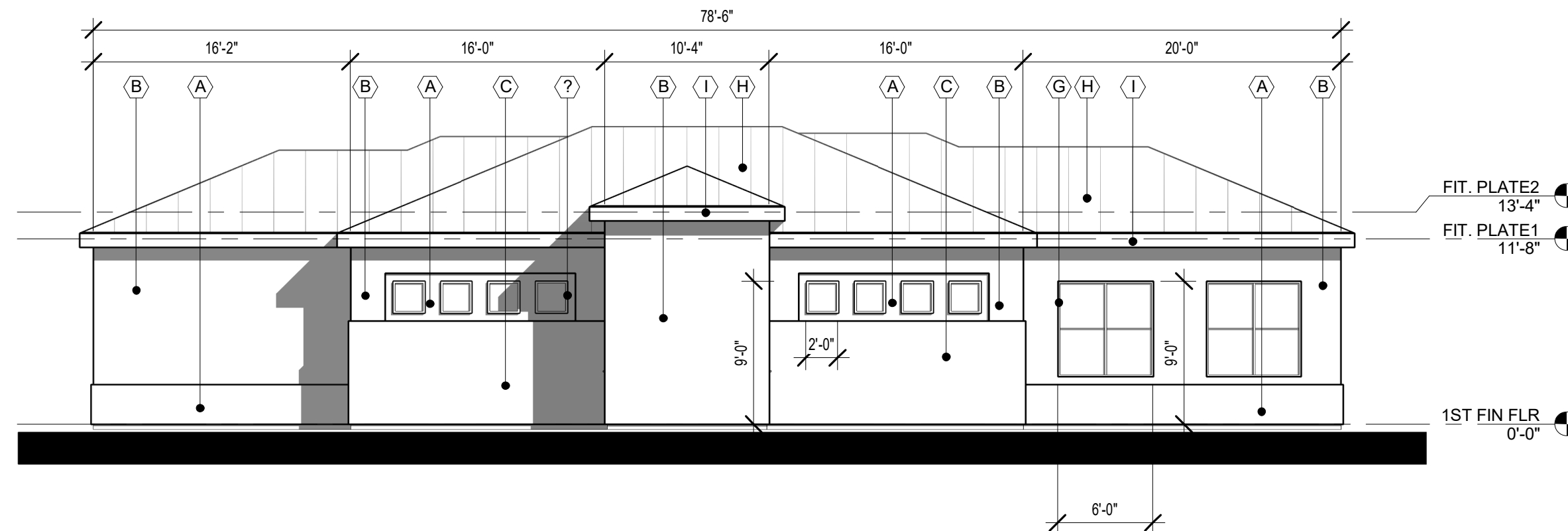

4 EXERCISE - REAR ELEVATION  
SCALE: 1/8" = 1'-0"

MATERIAL AND COLOR KEY

A	STUCCO LIGHT YELLOW LRV 50
B	STUCCO LIGHT BROWN LRV 42
C	STUCCO DARK BROWN LRV 27
D	GARAGE DOOR PAINTED DARK BROWN LRV 27
E	STUCCO LIGHT RED LRV 20
F	METAL RAILINGS COLOR WHITE
G	VINYL WINDOWS COLOR WHITE
H	GREY METAL ROOF LRV TO BE BETWEEN 20 & 50
I	METAL FASCIA COLOR WHITE

**ALLASO  
HIGH DESERT**  
SWC TENNYSON STREET AND SAN ANTONIO DR.  
ALBUQUERQUE, NEW MEXICO

Office of Rich Barber  
**ORB**  
Architecture  
WorldHQ@ORBArch.com



**TITAN**  
DEVELOPMENT

DRB SUBMITTAL  
DATE: OCTOBER 5, 2020 ORB #: 19-209

**A5.23**  
BUILDING EXERCISE & POOL  
RAMADA ELEVATIONS



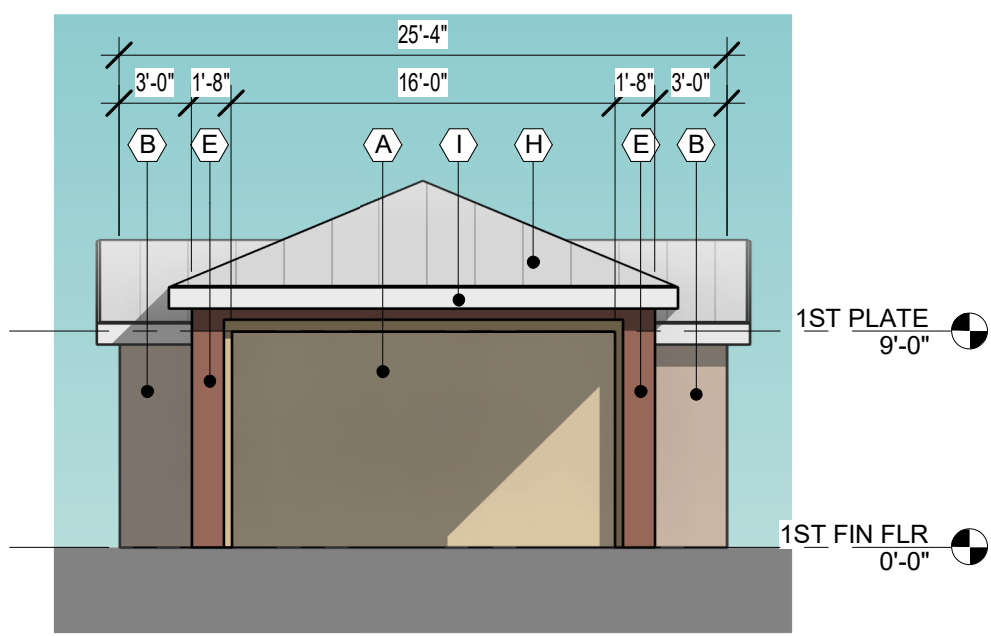

5 POOL RAMADA - FRONT ELEVATION  
SCALE: 1/8" = 1'-0"

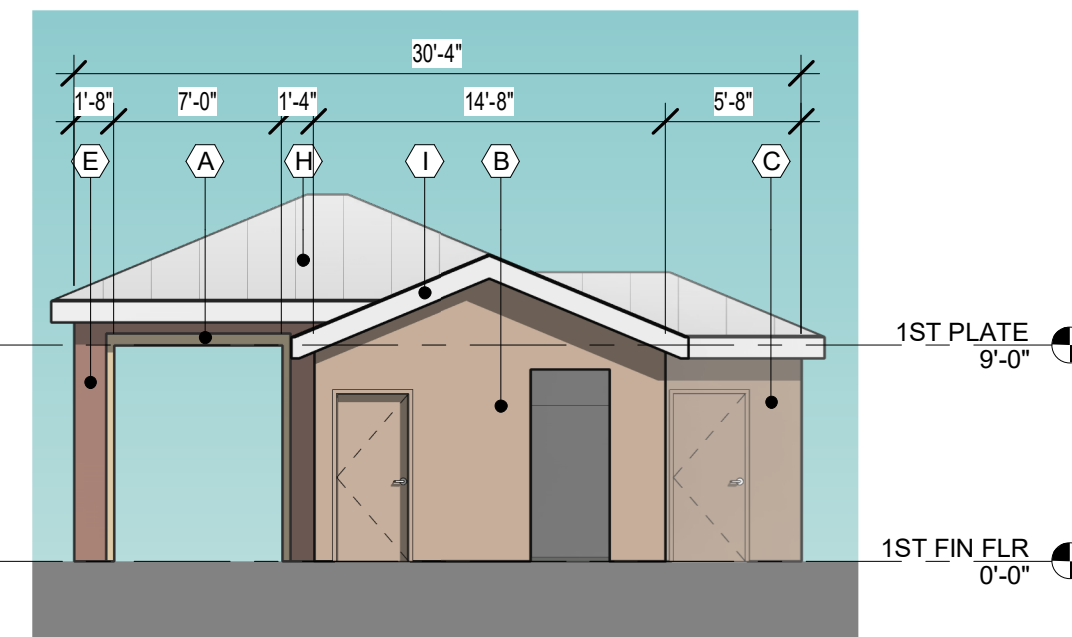

6 POOL RAMADA - RIGHT ELEVATION  
SCALE: 1/8" = 1'-0"

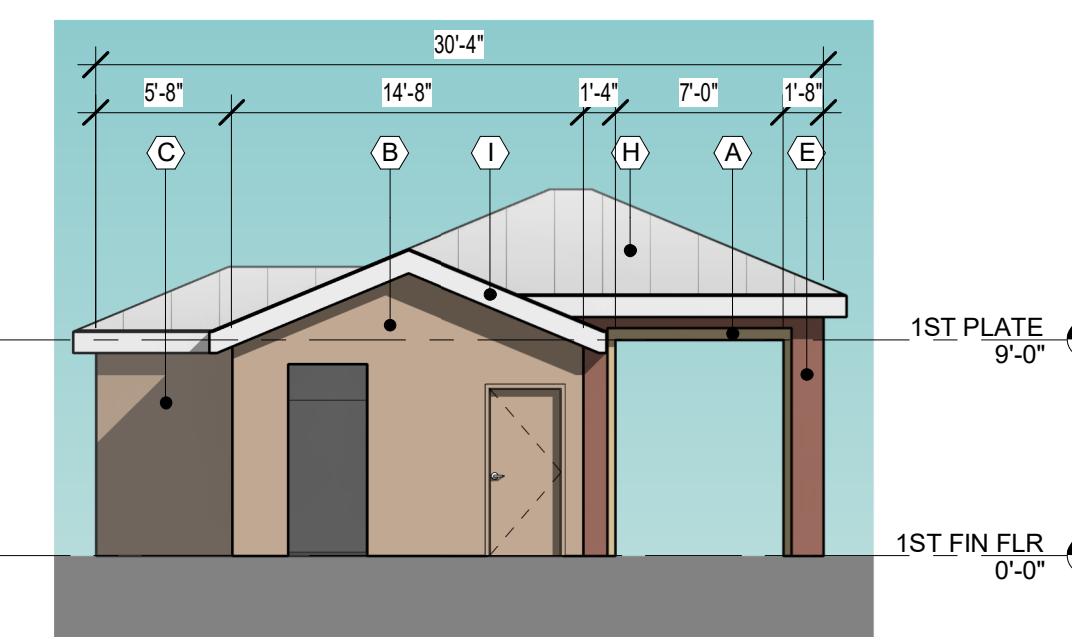

7 POOL RAMADA - LEFT ELEVATION  
SCALE: 1/8" = 1'-0"

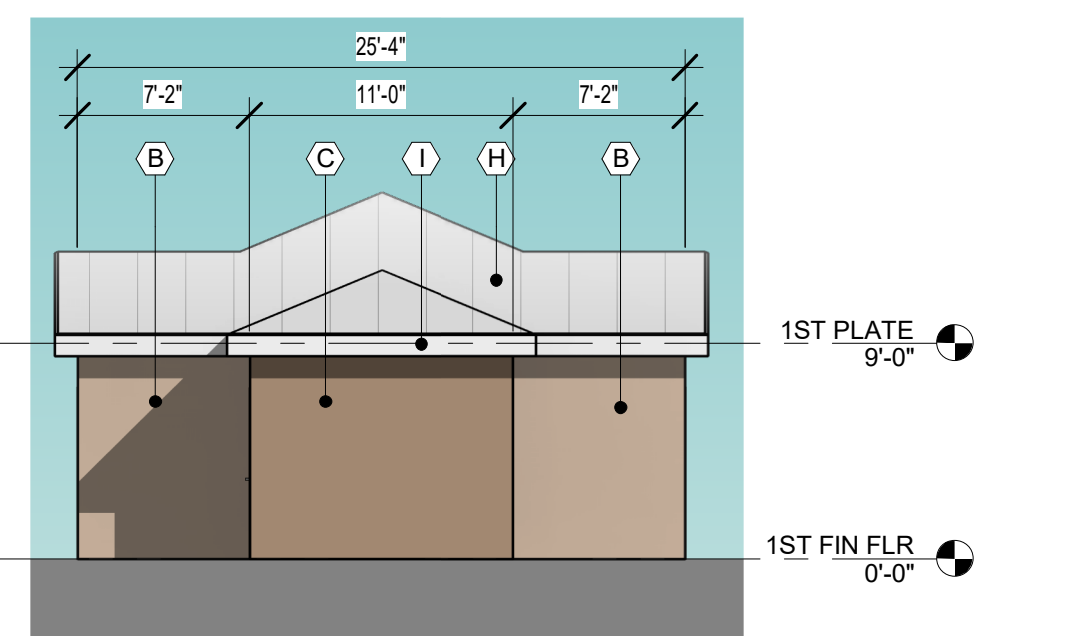

8 POOL RAMADA - REAR ELEVATION  
SCALE: 1/8" = 1'-0"

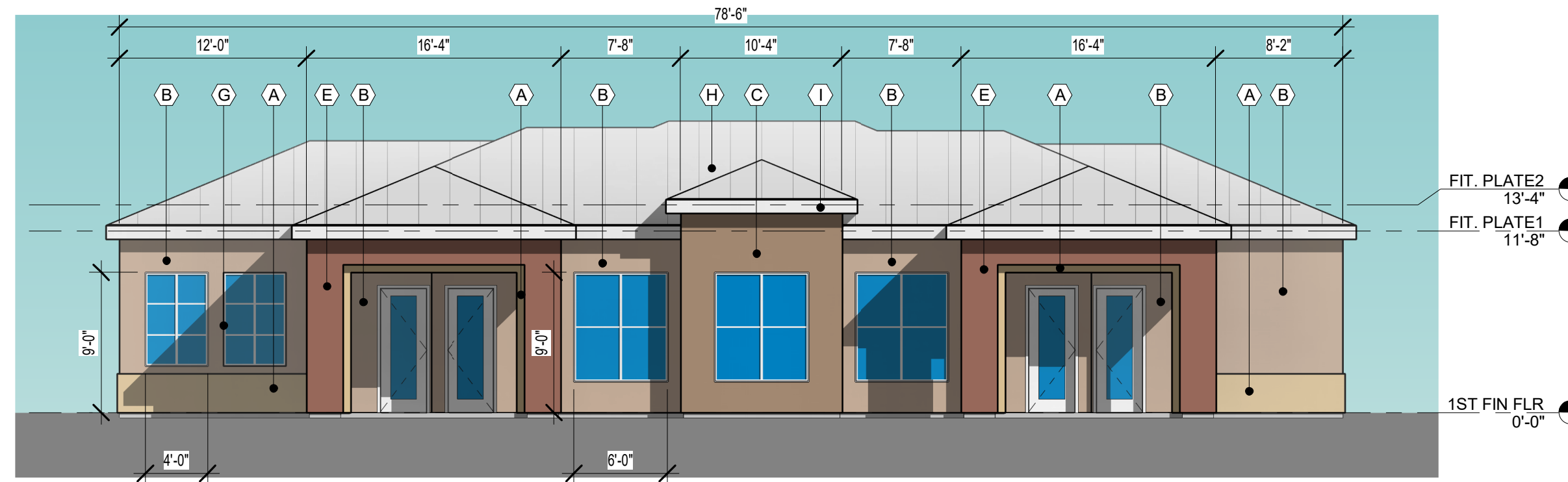

1 EXERCISE - FRONT ELEVATION  
SCALE: 1/8" = 1'-0"

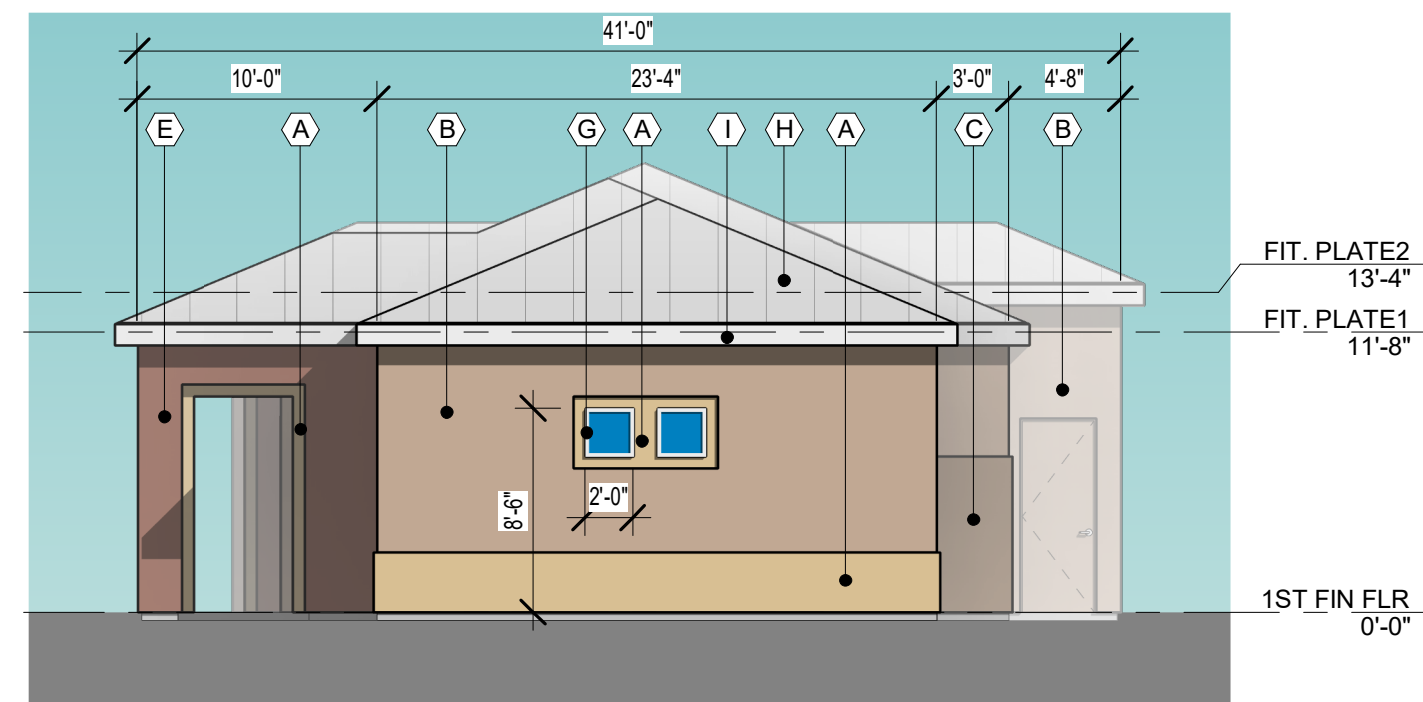

2 EXERCISE - RIGHT ELEVATION  
SCALE: 1/8" = 1'-0"

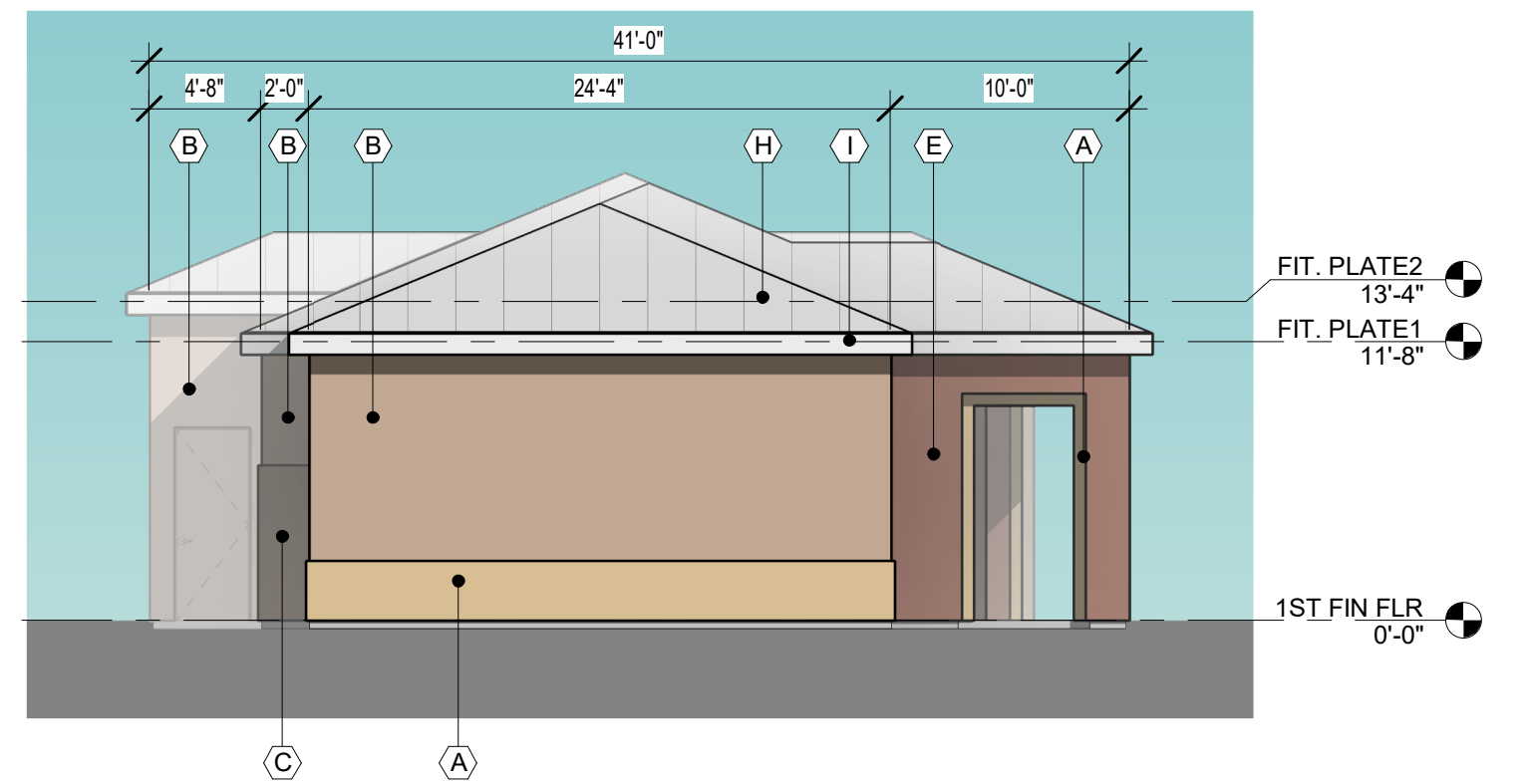

3 EXERCISE - LEFT ELEVATION  
SCALE: 1/8" = 1'-0"

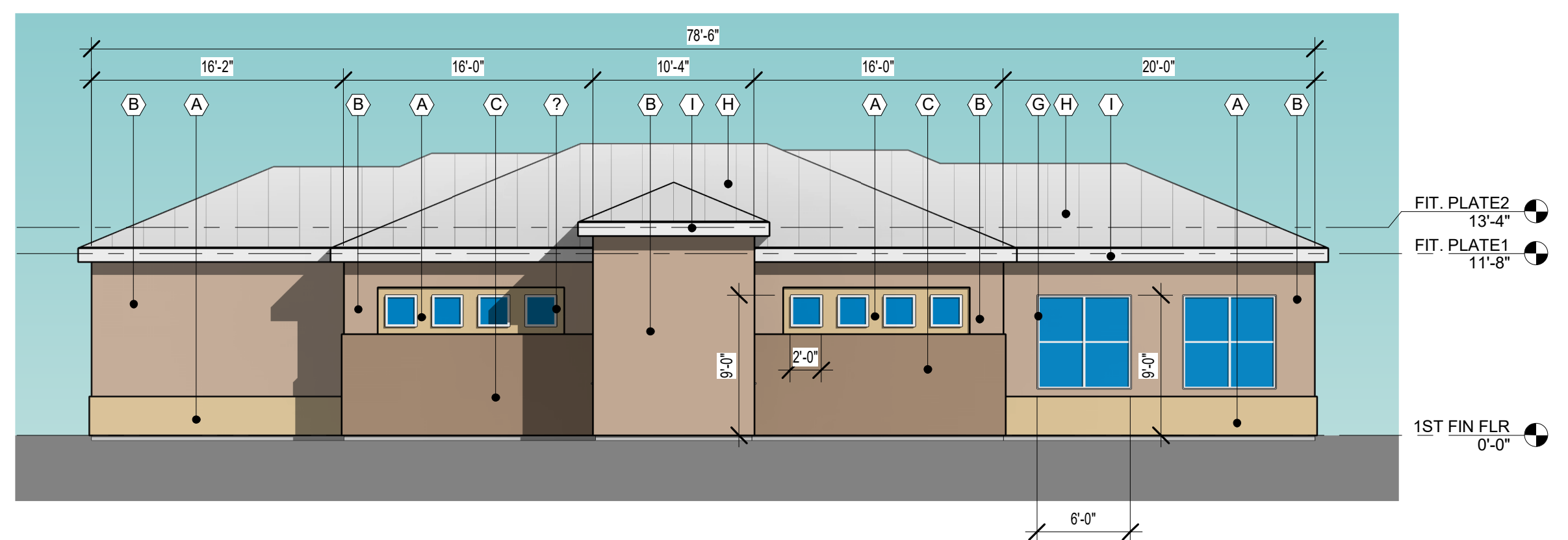

4 EXERCISE - REAR ELEVATION  
SCALE: 1/8" = 1'-0"

MATERIAL AND COLOR KEY

A	STUCCO LIGHT YELLOW LRV 50
B	STUCCO LIGHT BROWN LRV 42
C	STUCCO DARK BROWN LRV 27
D	GARAGE DOOR PAINTED DARK BROWN LRV 27
E	STUCCO LIGHT RED LRV 20
F	METAL RAILINGS COLOR WHITE
G	VINYL WINDOWS COLOR WHITE
H	GREY METAL ROOF LRV TO BE BETWEEN 20 & 50
I	METAL FASCIA COLOR WHITE

ALLASO HIGH DESERT  
SWC TENNYSON STREET AND SAN ANTONIO DR.  
ALBUQUERQUE, NEW MEXICO



DRB SUBMITTAL  
DATE: OCTOBER 5, 2020 ORB #: 19-209

A5.23C  
BUILDING EXERCISE & POOL  
RAMADA COLOR ELEVATIONS