

VICINITY MAP (F-18) NO SCALE

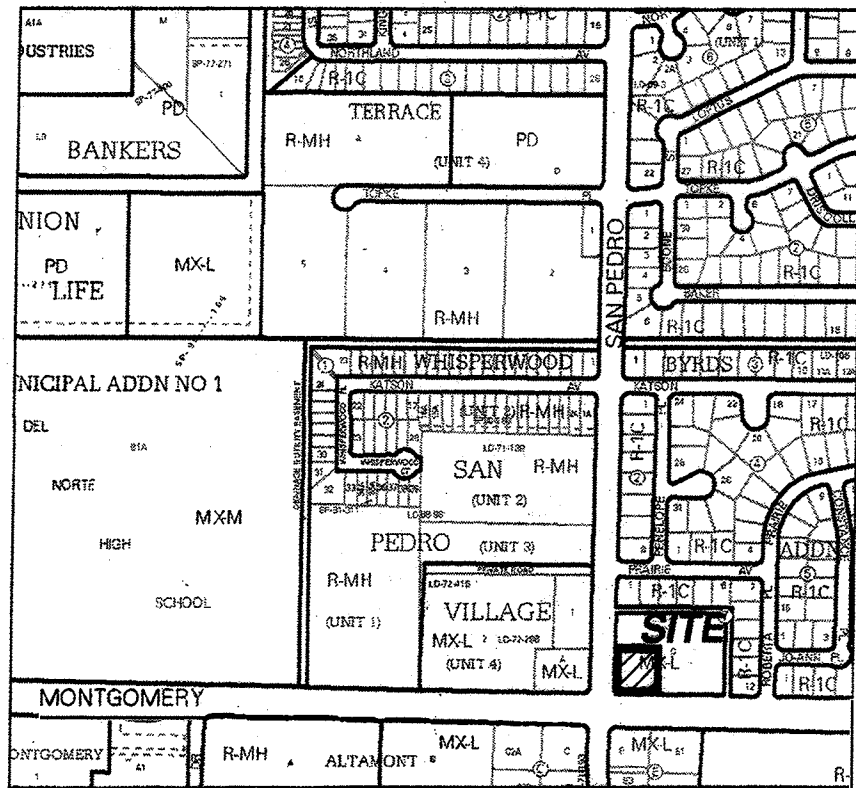

COUNTY CLERK RECORDING LABEL HERE

PLAT OF  
LOTS C-1 AND C-2, BLOCK 7  
BOYD'S ADDITION

A SUBDIVISION OF THE SOUTHWEST PORTION  
OF LOT C, BLOCK 7, BOYD'S ADDITION  
WITHIN SECTION 36, T. 11 N., R. 3 E., N.M.P.M.  
ALBUQUERQUE, BERNALILLO COUNTY, NEW MEXICO  
OCTOBER 2021

SURVEY LEGAL DESCRIPTION

A TRACT OF LAND BEING AND COMPRISING A PORTION OF LOT LETTERED "C" IN BLOCK NUMBERED SEVEN (7) OF BOYD'S ADDITION TO THE CITY OF ALBUQUERQUE, NEW MEXICO, BEING A REPLAT OF TRACTS "C", "D", "E" AND "F" OF THE REPLAT OF MUNICIPAL ADDITION NO. 1, AS THE SAME IS SHOWN AND DESIGNATED ON THE PLAT OF SAID ADDITION, FILED IN THE OFFICE OF THE COUNTY CLERK OF BERNALILLO COUNTY, NEW MEXICO, ON APRIL 10, 1963, AND REFILED APRIL 24, 1963 AND BEING MORE PARTICULARLY DESCRIBED AS FOLLOWS:

BEGINNING AT THE NORTHWEST CORNER OF THE HEREIN DESCRIBED TRACT, SAID CORNER BEING ALSO A POINT ON THE EASTERLY RIGHT-OF-WAY LINE OF SAN PEDRO BOULEVARD, NE., FROM WHENCE THE ALBUQUERQUE CONTROL STATION MONUMENT "9-F18"(X=1539870.687, Y=1504358.281, NM CENTRAL ZONE, NAD83) BEARS N. 67°51'02" W, 2834.00 FEET DISTANT;

THENCE, RUNNING FROM SAID POINT OF BEGINNING, S. 88°56'01"E., 150.06 FEET TO THE NORTHEAST CORNER OF THE TRACT HEREIN DESCRIBED; THENCE, RUNNING S. 01°21'57"W., 150.00 FEET DISTANT TO THE SOUTHEAST CORNER, BEING A POINT ON THE NORTHERLY RIGHT-OF-WAY OF MONTGOMERY BOULEVARD, NE; THENCE, RUNNING ALONG SAID RIGHT-OF-WAY N. 88°49'05" W., 124.91 FEET DISTANT TO A POINT OF CURVATURE; THENCE RUNNING ALONG A CURVE TO THE RIGHT 39.39 FEET DISTANT AND HAVING A RADIUS OF 25 FEET (CHORD: N. 43°44'43" W, 35.44 FEET, CENTRAL ANGLE: 89°42'39"); THENCE RUNNING N. 01°21'14"E, 125.33 FEET DISTANT, ALONG THE EASTERLY RIGHT-OF-WAY OF SAN PEDRO BOULEVARD, NE, TO THE NORTHWEST CORNER AND POINT OF BEGINNING; CONTAINING 0.5143 ACRES MORE OR LESS.

PROJECT NUMBER: PR-2020-004215

Application Number: SD\_2022\_00028

Utility Company Approvals:

*Jeff Estvanko*  
PNM Electric Services  
Digitally signed by Jeff Estvanko  
Date: 2022.02.17 12:48:46 -0700

02/17/2022  
Date

New Mexico Gas Company  
*Natalia Antonia*  
Qwest Corporation D/B/A Centurylink QC

2/15/2022  
Date

*[Signature]*  
City Approvals:

2/21/22  
Date

*[Signature]*  
City Surveyor

2/19/2022  
Date

Real Property Division

Date

Environmental Health Department

Date

Traffic Engineering, Transportation Division

Date

ABCWUA

Date

Parks and Recreation Department

Date

*[Signature]*  
AMAFCA

3/14/2022  
Date

City Engineering/Hydrology

Date

Code Enforcement

Date

DRB Chairperson, Planning Department

Date

PURPOSE OF PLAT

This plat has been prepared for the purpose of creating Two lots from one existing lot.

NOTES

- Bearings shown on this plat are New Mexico State Plane Grid, Central Zone, NAD 83. Bearings and distances in parenthesis are from existing plat.
- Perimeter distances are field measurements made on the ground.
- Monuments recovered and accepted or reset are noted on inscribed plat.
- No property within the area of requested plat shall at any time be subject to a deed restriction, covenant, or binding agreement prohibiting solar collectors from being installed on buildings or erected on the lots or parcels within the area of proposed plat. The foregoing requirement shall be a condition to approval of this plat.
- A 24' Private Cross-Lot Access Easement for the benefit of Lots C1 & C2 granted by this plat. Maintenance of this easement is the responsibility of the owners of Lots C-1 and C-2 respectively.
- A Blanket Drainage Easement for the benefit of Lots C1 & C2 granted by this plat. Maintenance of this easement is the responsibility of the owners of Lots C-1 and C-2 respectively.

FREE CONSENT

The platting of the property as described above is with the free consent and in accordance with the desires of the undersigned owner(s). Said owner(s) warrant(s) that they hold complete and indefeasible title in fee simple to the land subdivided.

Glen Cherry, Authorized Representative of Durban Development Date

ACKNOWLEDGMENT

STATE OF *New Mexico*  
COUNTY OF *Albuquerque*  
On this *27* day of *February*, 2022, the foregoing instrument was acknowledged by:  
Glen Cherry, Authorized Representative of Durban Development.

My Commission expires *April 19, 2025*  
*[Signature]*  
Notary Public

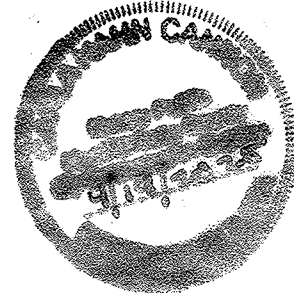

PUBLIC UTILITY EASEMENTS

Public utility easements shown on this plat are granted for the common and joint use of:  
A. Public Service Company of New Mexico ("PNM"), a New Mexico corporation, (PNM Electric) for installation, maintenance, and service of overhead and underground electrical lines, transformers, and other equipment and related facilities reasonably necessary to provide electrical services.  
B. New Mexico Gas Company for installation, maintenance, and service of natural gas lines, valves and other equipment and facilities reasonably necessary to provide natural gas services.  
C. Qwest Corporation d/b/a CenturyLink QC for the installation, maintenance, and service of such lines, cable, and other related equipment and facilities reasonably necessary to provide communication services.  
D. Cable TV for the installation, maintenance, and service of such lines, cable, and other related equipment and facilities reasonably necessary to provide Cable services.  
Included, is the right to build, rebuild, construct, reconstruct, locate, relocate, change, remove, replace, modify, renew, operate and maintain facilities for purposes described above, together with free access to, from, and over said easements, with the right and privilege of going upon, over and across adjoining lands of Grantor for the purposes set forth herein and with the right to utilize the right of way and easement to extend services to customers of Grantee, including sufficient working area space for electric transformers, with the right and privilege to trim and remove trees, shrubs or bushes which interfere with the purposes set forth herein. No building, sign, pool (aboveground or subsurface), hot tub, concrete or wood pool decking, or other structure shall be erected or constructed on said easements, nor shall any well be drilled or operated thereon. Property owners shall be solely responsible for correcting any violations of National Electrical Safety Code by construction of pools, decking, or any structures adjacent to or near easements shown on this plat.  
Easements for electric transformer/switchgears, as installed, shall extend ten (10) feet in front of transformer/switchgear doors and five (5) feet on each side.  
Disclaimer  
In approving this plat, Public Service Company of New Mexico (PNM), New Mexico Gas Company (NMGC) and Qwest Corporation d/b/a CenturyLink (QWEST) did not conduct a Title Search of the properties shown hereon. Consequently, PNM, NMGC and QWEST do not waive or release any easement or easement rights which may have been granted by prior plat, replat or other document and which are not shown on this plat.

SURVEYOR'S CERTIFICATE

I, Thomas D. Johnston, licensed as a Professional Surveyor under the laws of the State of New Mexico, do hereby certify that this plat was prepared by me or under my supervision, that I am responsible for this plat, that it shows all easements of the recorded plat and made known to me by the title company, utility companies or by the owner of record, meets the minimum standards for monumentation and surveys of the Albuquerque Subdivision Ordinance, and meets the Minimum Standards for Land Surveys as adopted by the New Mexico State Board of Licensure for Professional Engineers and Surveyors, effective July 24, 2016 and is true and correct to the best of my knowledge and belief.

*[Signature]*  
Thomas D. Johnston, N.M.P.S. No. 14269  
Date: 2-01-2022

SUBDIVISION DATA

- DRB Project No. PR-2020-004215
- Zone Atlas Index No. F-18
- Gross acreage 0.5144 Ac.
- Existing number of lots 1  
Replatted number of lots 2

FOR BERNALILLO COUNTY TREASURER'S OFFICE USE ONLY  
THIS IS TO CERTIFY THAT TAXES ARE CURRENT AND PAID ON  
UPC# 1 018 081 284 023 401 01

PROPERTY OWNER OF RECORD:  
ETHRIDGE PROPERTIES, LLC  
BERNALILLO COUNTY TREASURER'S OFFICE

1609 2nd STREET NW  
ALBUQUERQUE, N.M. 87102  
PHONE: (505) 255-2052 FAX: (505) 255-2887

INDEXING INFORMATION FOR COUNTY CLERK ETHRIDGE PROPERTIES LLC	DRAWN: JTK	SCALE: 1" = 20'	FILE NO. SP-9-03-2021
LOCATION: SECTION 36, T11N, R3E BOYD'S ADDITION	CHECKED: TDJ	DRAWING NO. SP-9-03-2021.DWG	SHEET 1 OF 2
		1 FEB 2022	

PLAT OF  
**LOTS C-1 AND C-2, BLOCK 7**  
**BOYD'S ADDITION**

A SUBDIVISION OF THE SOUTHWEST PORTION  
 OF LOT C, BLOCK 7, BOYD'S ADDITION  
 WITHIN SECTION 36, T. 11 N., R. 3 E., N.M.P.M.  
 ALBUQUERQUE, BERNALILLO COUNTY, NEW MEXICO  
 OCTOBER 2021

COUNTY CLERK RECORDING LABEL HERE

ACS MONUMENT "9-F18"  
 x=1,539,870.687 US SURVEY FEET  
 y=1,504,358.281 US SURVEY FEET  
 Ground-to-grid:  
 0.999666141  
 Mapping Angle:  
 -00°11'36.74"  
 NMSZ CENTRAL ZONE  
 NAD 83

REMAINING PORTION OF LOT C  
 BOYD'S ADDITION  
 ( REC 4/24/1963 IN VOL. C5, FOLIO 157 )

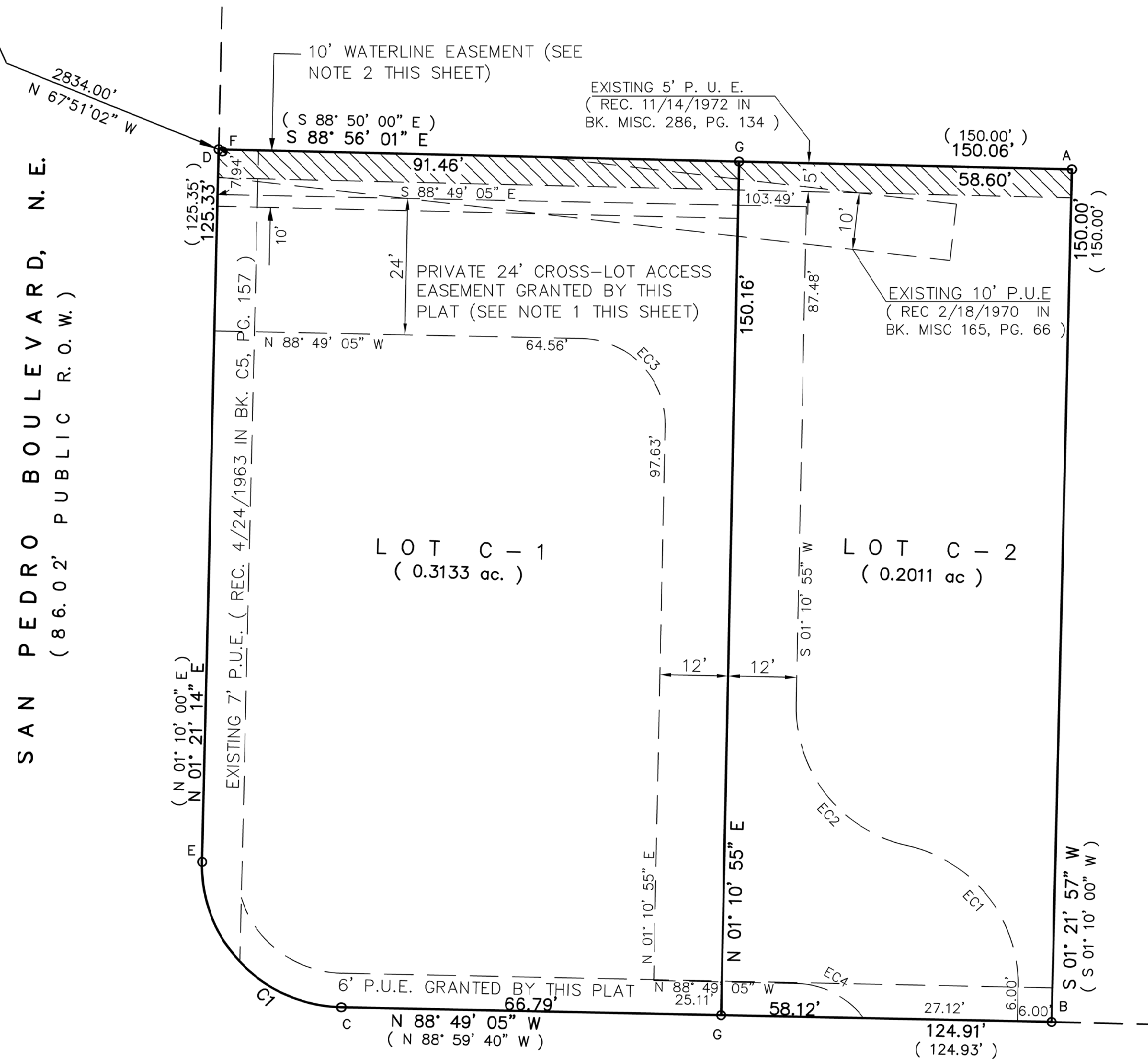

REMAINING PORTION OF LOT C  
 BOYD'S ADDITION  
 ( REC 4/24/1963 IN VOL. C5, FOLIO 157 )

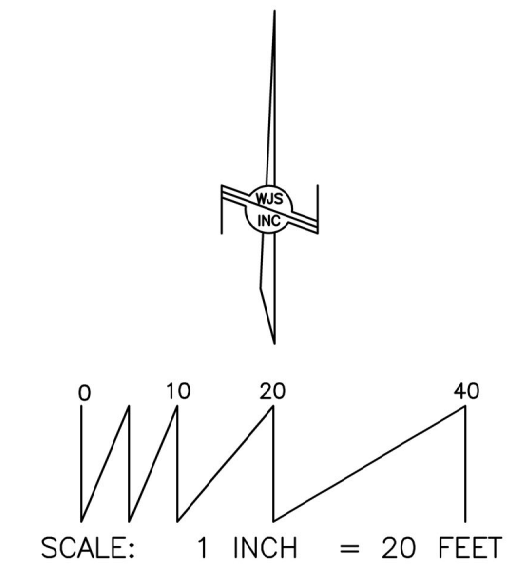

**MONUMENT LEGEND:**  
 ○ = FOUND/SET MONUMENT AS NOTED:  
 A: FOUND #4 REBAR AND CAP "LS 8686"  
 B: FOUND PK NAIL AND DISK "LS 8686"  
 C: FOUND PK NAIL AND DISK "PS 14271"  
 D: FENCE CORNER AT PROPERTY CORNER  
 E: FOUND "+" IN CONCRETE  
 F: FOUND #5 REBAR - NOT ACCEPTED  
 G: SET PK NAIL AND DISK "PS 14269"

The subject properties (as shown hereon) appear to lie within "Zone X" (Area of minimal flood hazard and determined to be outside the 1% annual chance floodplain) as shown on the National Flood Insurance Program Flood Insurance Rate Map Number 35001C0139G Revised September 26, 2008.

**MONTGOMERY BOULEVARD, N.E.**  
 ( 118' PUBLIC R.O.W. )

CURVE TABLE				
CURVE NO.	RADIUS	LENGTH	CENTRAL ANGLE	CHORD
C1	25.00'	39.39'	89° 42' 39"	N 43° 44' 43" W, 35.44'
(C1)	25.00'	39.34'	--	--
EC1	25.00'	34.29'	78° 35' 50"	N 38° 07' 00" W, 31.67'
EC2	25.00'	34.29'	78° 35' 50"	N 38° 07' 00" W, 31.67'
EC3	15.00'	23.56'	90° 00' 00"	N 43° 49' 05" W, 21.21'
EC4	15.00'	13.72'	52° 24' 38"	S 62° 36' 46" E, 13.25'

NOTE 1: 24' PRIVATE CROSS-LOT ACCESS EASEMENT FOR THE BENEFIT OF LOTS C-1 AND C-2 IS GRANTED BY THIS PLAT. MAINTENANCE OF THIS EASEMENT IS THE RESPONSIBILITY OF THE OWNERS OF LOTS C-1 AND C-2.

NOTE 2: 10' PRIVATE WATERLINE EASEMENT IS GRANTED FOR THE BENEFIT LOT C-2 BY THIS PLAT. MAINTENANCE OF THIS EASEMENT IS THE RESPONSIBILITY OF THE OWNER OF LOT C-2.

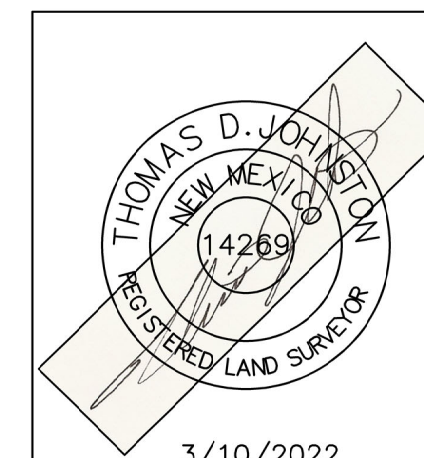

1609 2nd STREET NW  
 ALBUQUERQUE, N.M. 87102  
 PHONE: (505) 255-2052 FAX: (505) 255-2887

INDEXING INFORMATION FOR COUNTY CLERK  
 ETHRIDGE PROPERTIES LLC  
 LOCATION: SECTION 36, T11N, R3E  
 BOYD'S ADDITION

DRAWN: J T K  
 CHECKED: T D J  
 DRAWING NO.  
 SP-9-03-2021.DWG

SCALE:  
 1" = 20'  
 1 FEB 2022

FILE NO.  
 SP-9-03-2021  
 SHEET 2 OF 2