

SUBDIVISION PLAT

LOT 17A NORTH ALBUQUERQUE ACRES
TRACT 3 UNIT 3 BLOCK 9
BEING COMPRISED OF
LOTS 17-19 NAA TRACT 3 UNIT 3 BLOCK 9
AND
LOT 4 UNIT 1 DESERT RIDGE
CITY OF ALBUQUERQUE
BERNALILLO COUNTY, NEW MEXICO
OCTOBER 2020

PURPOSE

1. COMBINE LOTS AS SHOWN HEREON.
2. GRANT EASEMENTS AS SHOWN HEREON.
3. DEDICATE ROW TO CITY OF ALBUQUERQUE AS SHOWN HEREON.

SUBDIVISION DATA

GROSS AREA: 3.895 AC
ZONE ATLAS PAGE NO.: C20
NUMBER OF EXISTING LOTS: 4
NUMBER OF PROPOSED LOTS: 1
RIGHT-OF-WAY DEDICATION TO THE CITY OF ALBUQUERQUE: 0.55 AC

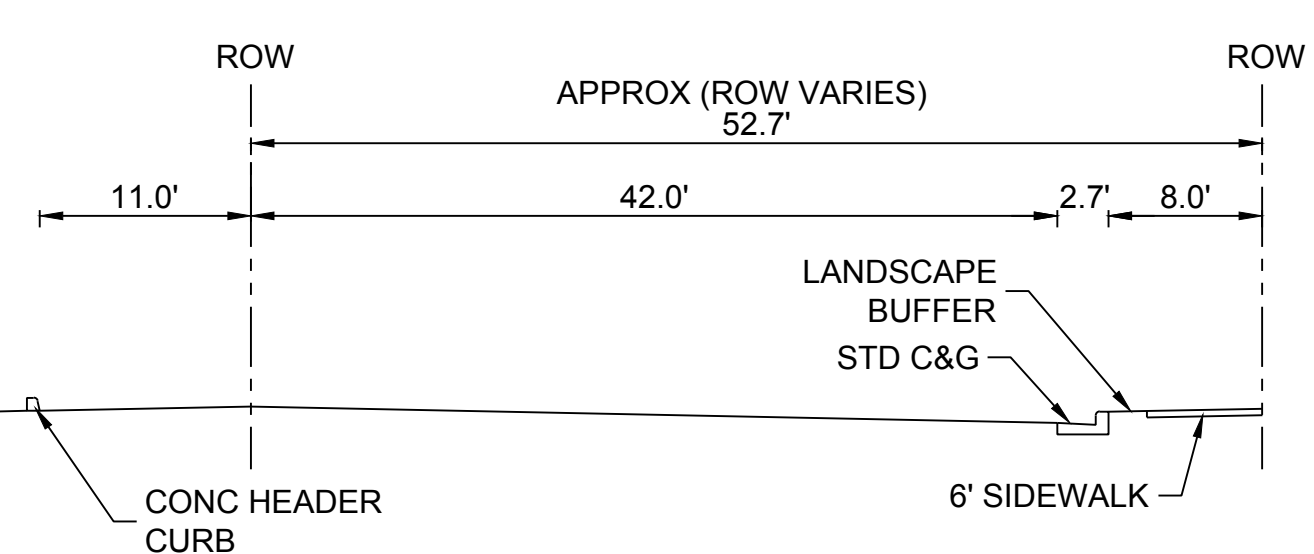
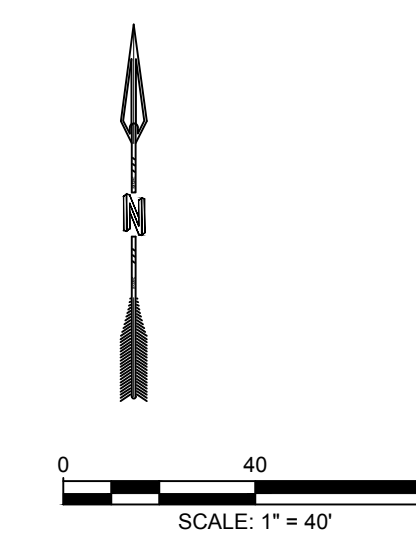
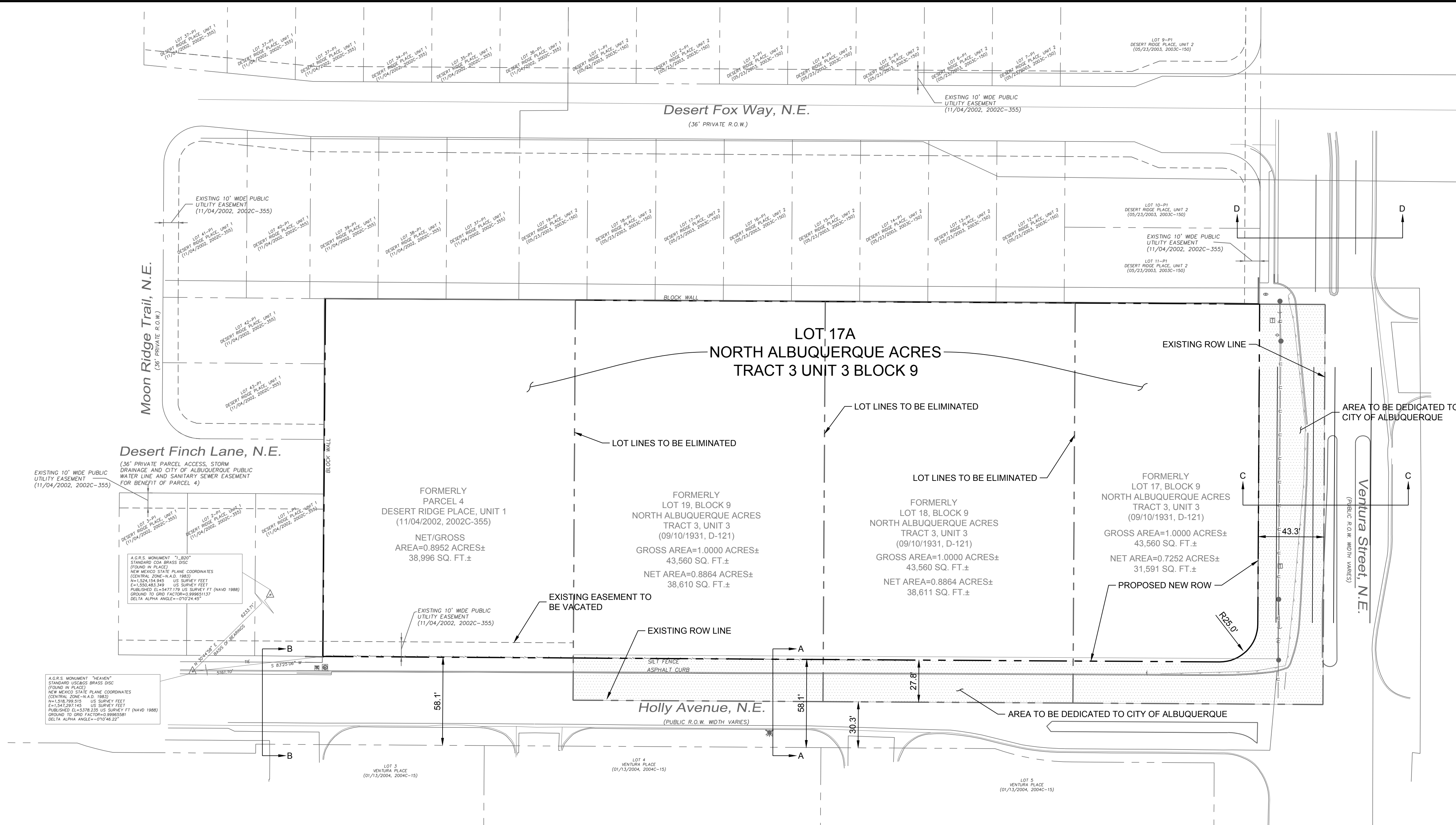

EXISTING SECTION C-C
SCALE: 1" = 10'

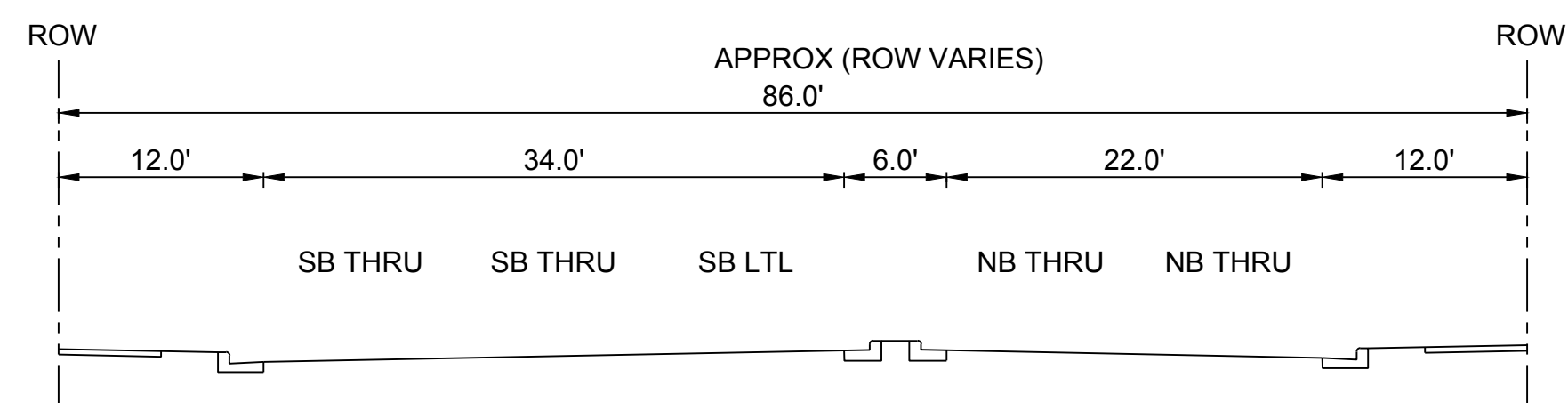

EXISTING SECTION D-D
SCALE: 1" = 10'

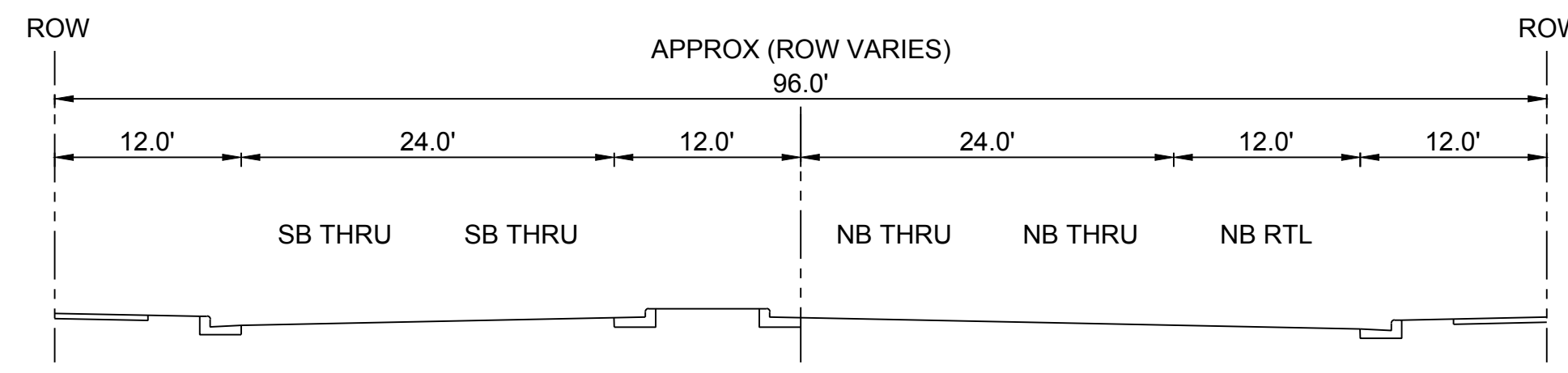

PROPOSED SECTION C-C (TO MATCH D-D PLUS NB TURN)
SCALE: 1" = 10'

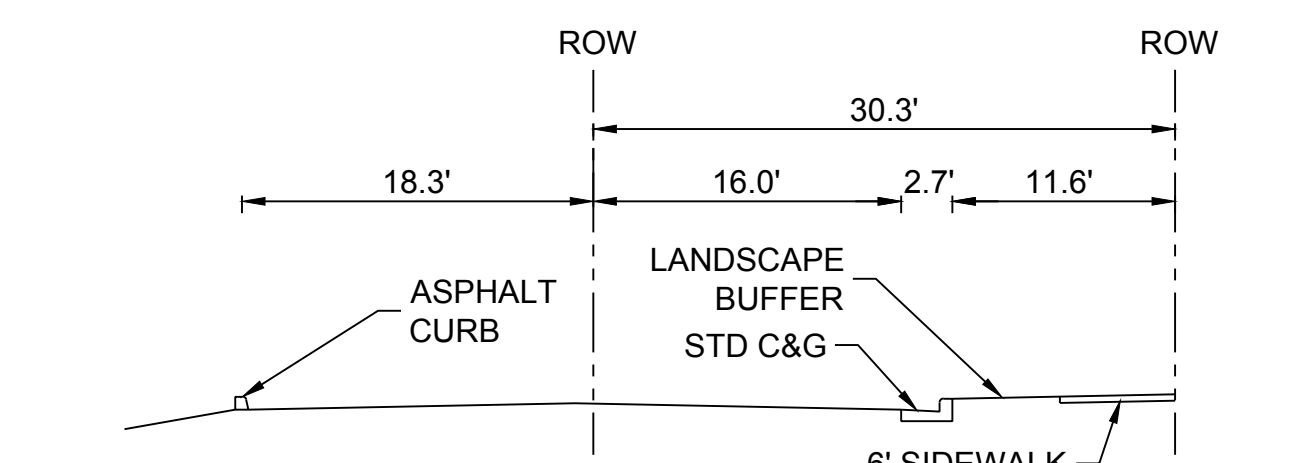

EXISTING SECTION A-A
SCALE: 1" = 10'

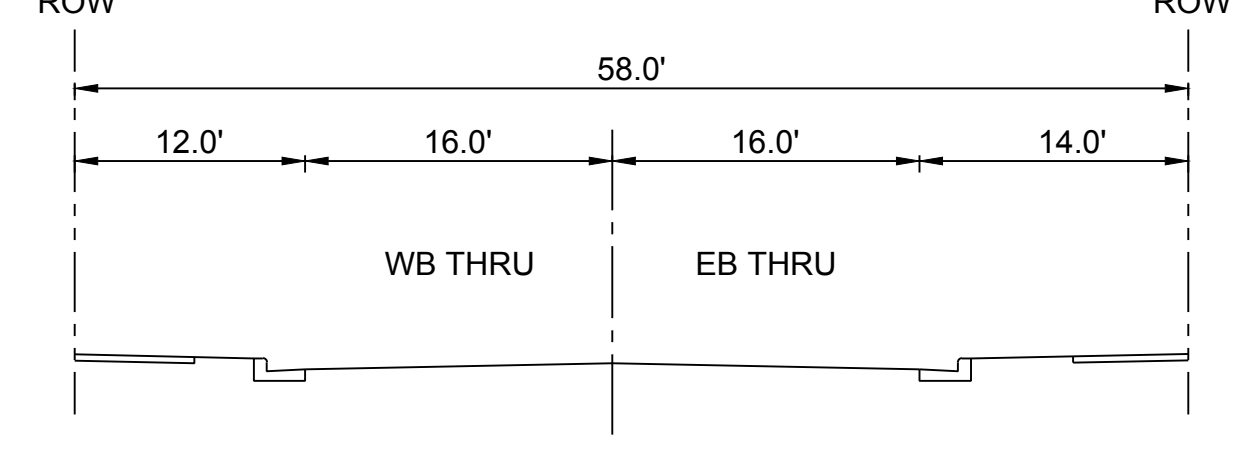

EXISTING SECTION B-B
SCALE: 1" = 10'

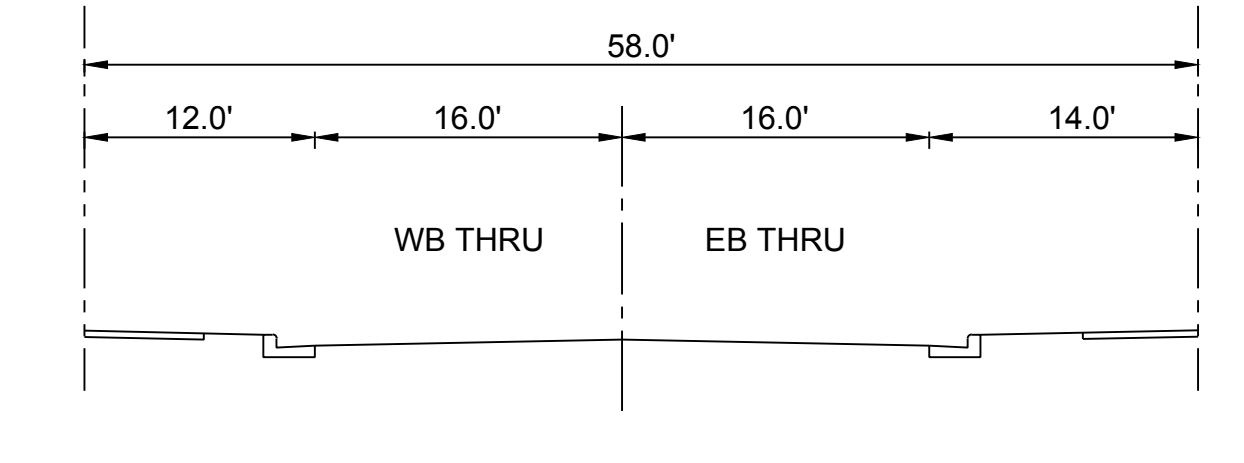

PROPOSED SECTION A-A (TO MATCH B-B)
SCALE: 1" = 10'



RESPEC

5971 JEFFERSON STREET SUITE 101
ALBUQUERQUE, NEW MEXICO 87109
WATER & NATURAL RESOURCES
WWW.RESPEC.COM 505.243.2287