

# CITY OF ALBUQUERQUE

Planning Department  
Alan Varela, Director



Mayor Timothy M. Keller

March 20, 2026

John T. Measels, PE  
JM Civil Engineering  
1101 Central Expressway S.  
Suite 215  
Allen, TX 75013

**Re: Circle K, INC**  
**9800 De Vargas Rd. SW**  
**Albuquerque, NM 87121**  
**Traffic Circulation Layout**  
Engineer's Stamp 11-12-25 (M09D012A)

Dear Mr. Measels,

The TCL submittal received 02-19-2026 is approved for Building Permit by Transportation. A copy of the stamped and signed plan will be needed for each of the building permit plans. Please keep the original to be used for certification of the site for final C.O. for Transportation.

PO Box 1293

When the site construction is completed and an inspection for Certificate of Occupancy (C.O.) is requested, use the original City stamped approved TCL for certification. Redline any minor changes and adjustments that were made in the field. A NM registered architect or engineer must stamp, sign, and date the certification TCL along with indicating that the development was built in "substantial compliance" with the TCL. Submit this certification and the TCL to ABQ-Plan for log in and evaluation by Transportation. **SHARED ACCESS EASEMENT AND/OR APPROVED PLAT AND AN APPROVED WORK ORDER ARE CONDITIONS FOR RELEASING THE FINAL CO.**

Albuquerque

NM 87103

[www.cabq.gov](http://www.cabq.gov)

Once verification of certification is completed and approved, notification will be made to Building Safety to issue Final C.O. To confirm that a final C.O. has been issued, call Building Safety at 924-3690.

Sincerely,

Ernest Armijo, P.E.  
Principal Engineer, Planning Dept.  
Development Review Services

C: CO Clerk, File

**CAUTION NOTICE TO CONTRACTOR**  
 THE CONTRACTOR IS SPECIFICALLY CAUTIONED THAT THE LOCATION AND/OR ELEVATION OF EXISTING UTILITIES AS SHOWN ON THESE PLANS ARE BASED ON RECORDS OF THE VARIOUS UTILITY COMPANIES AND, WHERE POSSIBLE, MEASUREMENTS TAKEN IN THE FIELD. THE INFORMATION IS NOT TO BE RELIED ON AS BEING EXACT OR COMPLETE. THE CONTRACTOR MUST CALL THE APPROPRIATE UTILITY COMPANY AT LEAST 7 DAYS BEFORE ANY EXCAVATION TO REQUEST EXACT FIELD LOCATION OF UTILITIES. IT SHALL BE THE RESPONSIBILITY OF THE CONTRACTOR TO RELOCATE ALL EXISTING UTILITIES HORIZONTALLY AND VERTICALLY WHICH CONFLICT WITH THE PROPOSED IMPROVEMENTS SHOWN ON THE PLANS.

**FLOODNOTE**  
 BASED UPON SCALING THIS PROPERTY LIES WITHIN FLOOD ZONE "X" WHICH IS DEFINED AS AN AREA OF MINIMAL FLOOD HAZARD AS DETERMINED BY FEMA AND SHOWN ON THE FLOOD INSURANCE RATE MAP NO. 35001C0336H AS PER ALTA SURVEY

**BENCHMARKS**  
 ACS MONUMENT 2-L7 NAD 1983 CENTRAL ZONE-NAVD 1988. X=1486604.908 Y=1480475.091 ELEVATION=5415.511'  
 ACS MONUMENT 11L-10 NAD 1983 CENTRAL ZONE-NAVD 1988. X=1499894.295 Y=1479206.196 ELEVATION=5081.821'

SITE DATA TABLE		
LOCATION:	SNOW VISTA BLVD DE VARGAS RD SW ALBUQUERQUE, NM 87121	
LOT AREA:	1.9274 AC. (83,955 S.F.)	
ZONING:	ZONING - NRC	
CURRENT USE:	VACANT	
PROPOSED USE:	C STORE W FUEL DISPENSING	
<b>BUILDING DATA:</b>		
BUILDING AREA:	5,200 S.F.	
BUILDING HEIGHT:	38' (1 STORY)	
BUILDING COVERAGE:	6.19%	
F.A.R.:	16:1	
<b>PARKING SUMMARY:</b>		
1 SP PER 200 SF (5,200 SF)	REQUIRED	PROVIDED
PARKING SPACES	25	25
ACCESSIBLE SPACES	1	2
TOTAL SPACES	26	27
MOTORCYCLE	2	2
BICYCLE	3	3

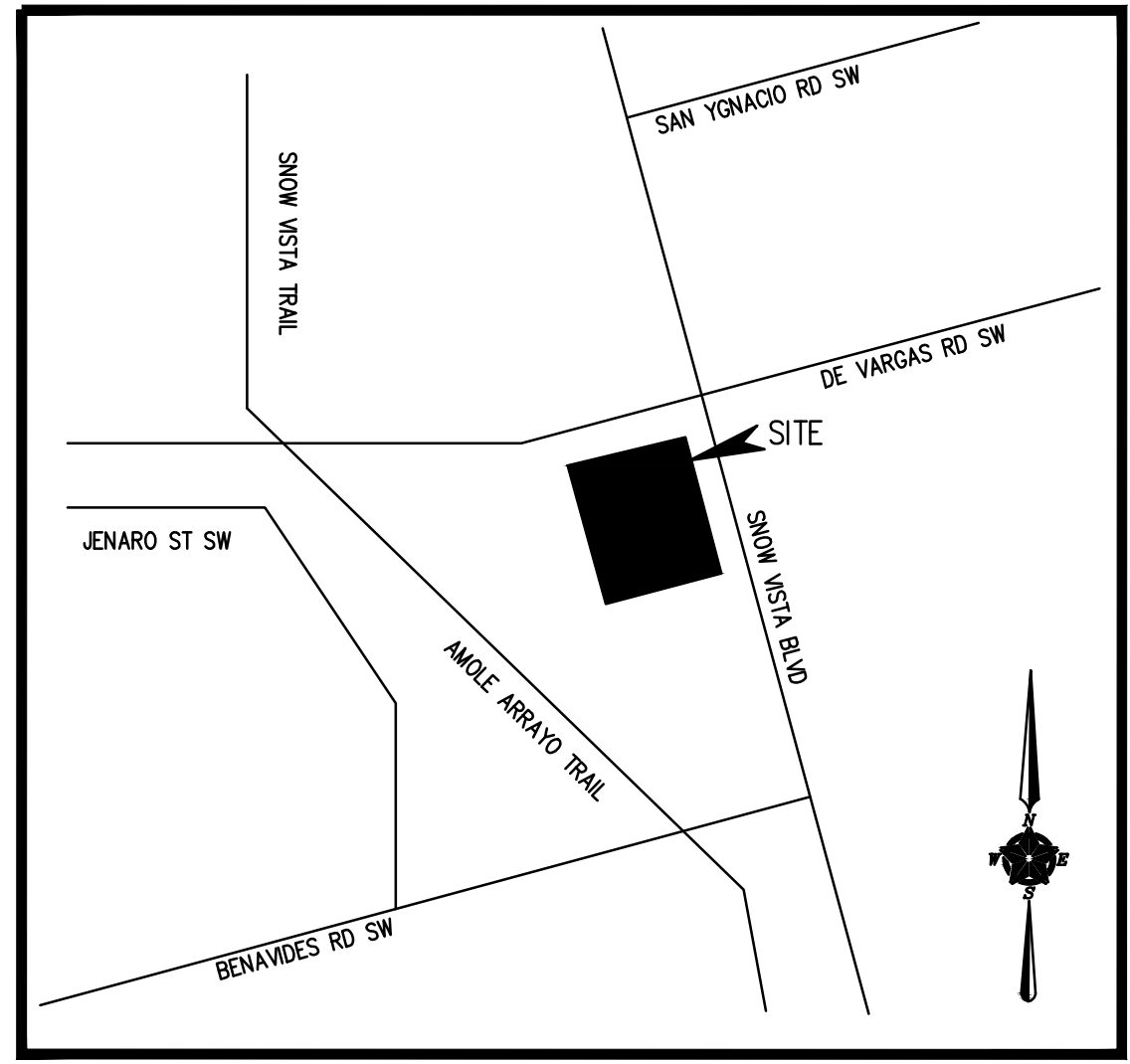

**LOCATION MAP**  
 ZONE ATLAS MAP NO. M-9-Z  
 NOT TO SCALE

- NOTES:**
- ALL BROKEN OR CRACKED SIDEWALK MUST BE REPLACED WITH SIDEWALK AND CURB AND GUTTER.
  - LANDSCAPING AND SIGNAGE WILL NOT INTERFERE WITH CLEAR SIGHT REQUIREMENT. THEREFORE, SIGNS WALLS, TREES AND SHRUBBERY BETWEEN 3 AND 8 FEET TALL (AS MEASURED FROM THE GUTTER PAN) WILL NOT BE ACCEPTABLE IN THE CLEAR SIGHT TRIANGLE.

**JM CIVIL**  
 1101 Central Expressway South  
 Suite 215  
 Allen, TX 75013  
 Ph. 214-491-1830  
 John Measles, PE  
 CIVIL ENGINEER

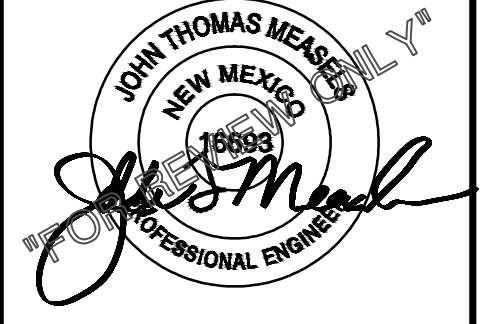

03/05/2026

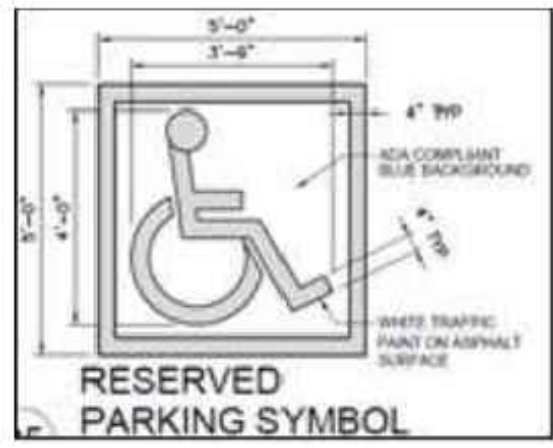
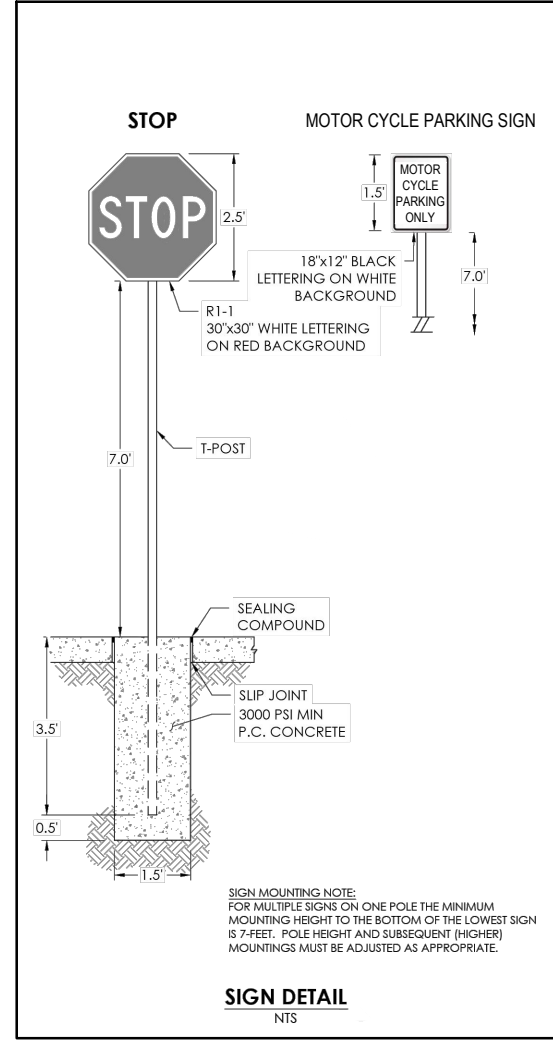

**HANDICAPPED STRIPING DETAIL**

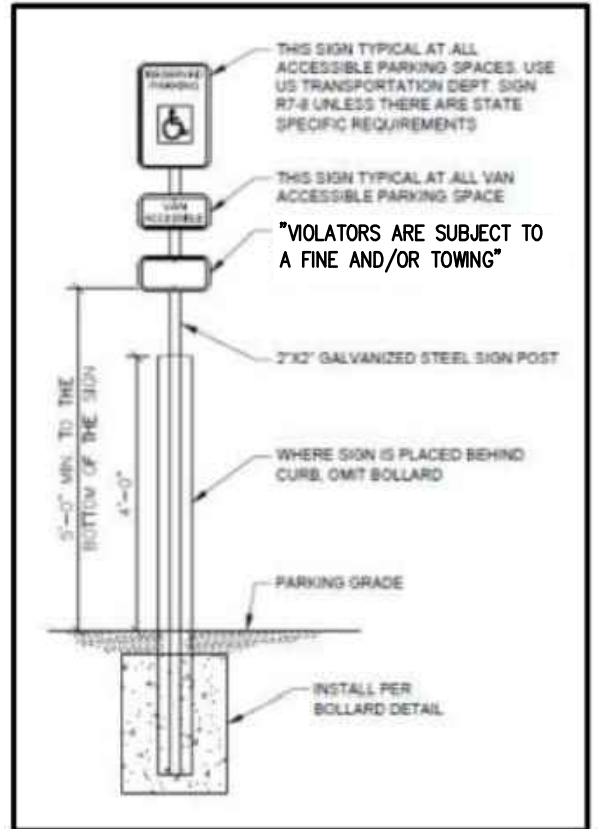

**HANDICAPPED SIGN DETAIL**

**TRAFFIC CIRCULATION LAYOUT APPROVED**  
 Ernest Armijo 3/20/2026  
 Signed Date

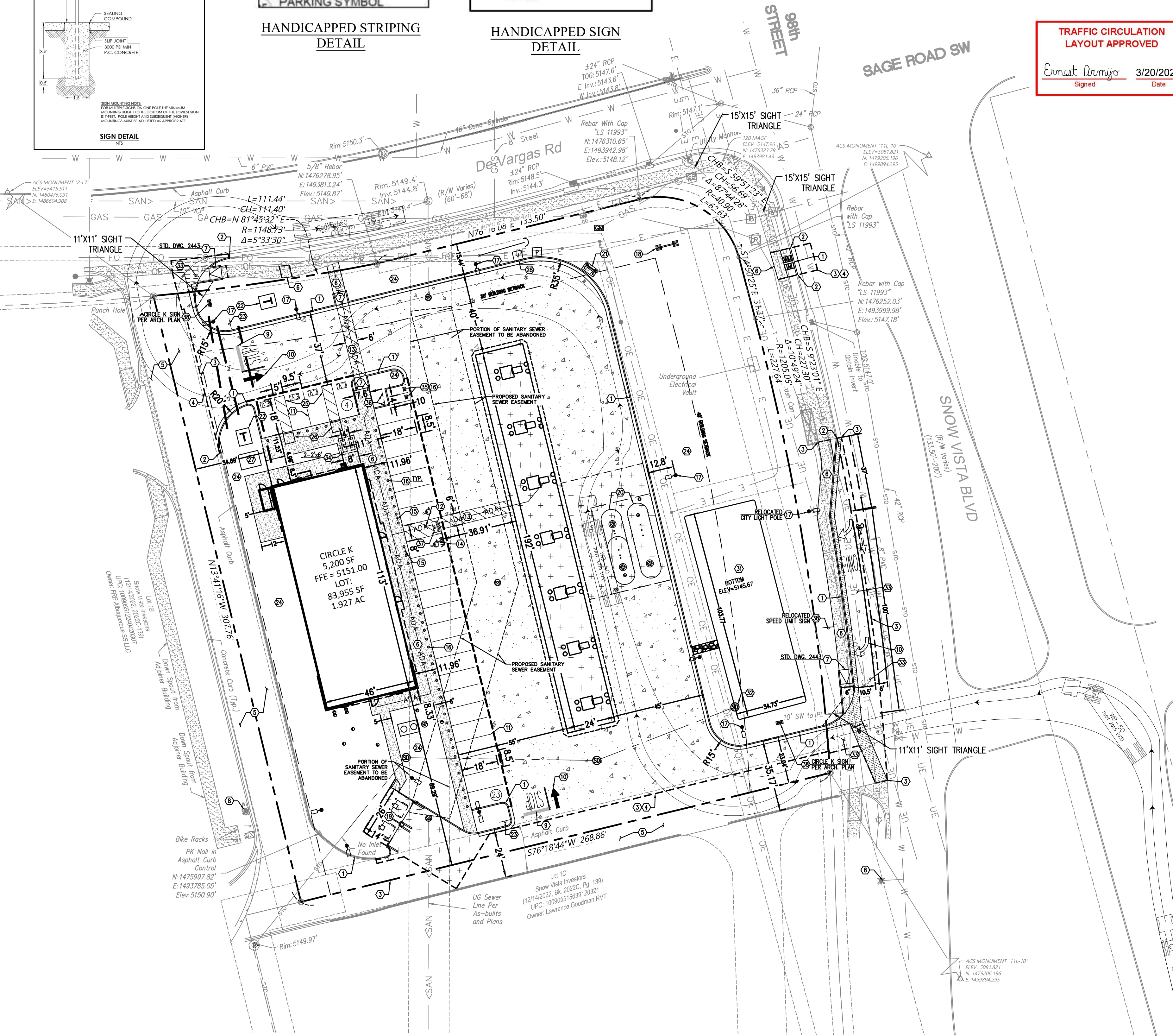

**SITE KEY NOTES:**

- CONCRETE CURB AND GUTTER. (CITY DETAIL #2415A & #2415B)
- TAPER CURB TO MATCH EXISTING.
- MATCH EXISTING PAVEMENT ELEVATION.
- LIMITS OF FULL DEPTH SAWCUT AND PAVEMENT REMOVAL.
- EXISTING PAVEMENT TO REMAIN.
- CONCRETE SIDEWALK. 2% MAX. CROSS SLOPE AND 5% MAX. STRAIGHT SLOPE. (CITY DETAIL #2430)
- SIDEWALK RAMP @ 8.33% MAX. (CITY DETAIL #2443)
- EXISTING FIRE HYDRANT.
- STOP BAR. (PER LOCAL CODES)
- DIRECTIONAL TRAFFIC ARROW. (PER LOCAL CODES)
- PARKING STALL STRIPING. (PER LOCAL CODES)
- 4" WIDE PAINTED STRIPES, 2" OFF CENTER @ 45'. (ALL HANDICAPPED PAINT SHALL BE BLUE)
- PEDESTRIAN/ACCESSIBLE CROSSWALK STRIPING.
- ACCESSIBLE STRIPING & SYMBOL. (TYPICAL-PER ADA AND LOCAL REQUIREMENTS)
- ACCESSIBLE SIGNS. (TYPICAL-PER ADA AND LOCAL REQUIREMENTS)
- BOLLARD.
- PROPOSED LIGHT POLE.
- MONUMENT/PYLON SIGN. (PER ARCH. PLANS)
- REFUSE/SOLID WASTE. (DETAIL PER ARCH. PLANS)
- FUEL STORAGE TANKS (PER M.E.P. PLANS)
- FUEL TANK VENTS (PER M.E.P. PLANS)
- PROPOSED PAD MOUNTED TRANSFORMER.
- "STOP" SIGN.
- LANDSCAPE AREA. (PER LANDSCAPE PLAN)
- EV PARKING STALLS.
- EV CHARGING EQUIPMENT.
- EV POWER BANK/GENERATOR.
- AIR/VAC. UNIT
- DIRECTIONAL SIGN FOR DRIVE THRU.
- STORAGE UNIT. (PER ARCH. PLANS)
- DETENTION BASIN.
- INLET. (SEE PLAN FOR SIZE)
- FLEXIBLE CITY PAVEMENT PER DETAIL #2405B
- BICYCLE PARKING. (PER ARCH. PLANS)
- MOTORCYCLE PARKING & "MC" STRIPING.
- MOTORCYCLE PARKING SIGN PER COA ZONING CODE.
- "NO PARKING" STRIPING.

**SITE LEGEND:**

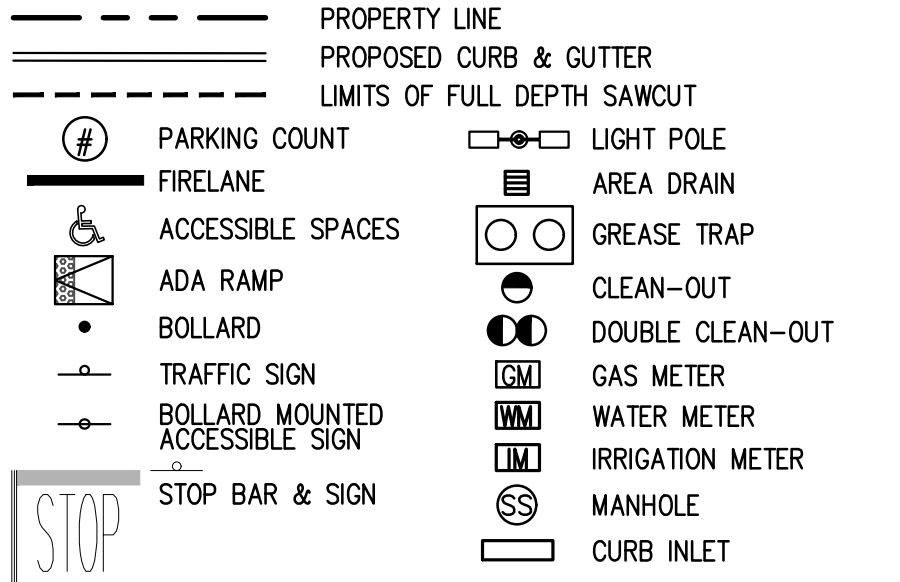

**PROPOSED PAVING LEGEND:**

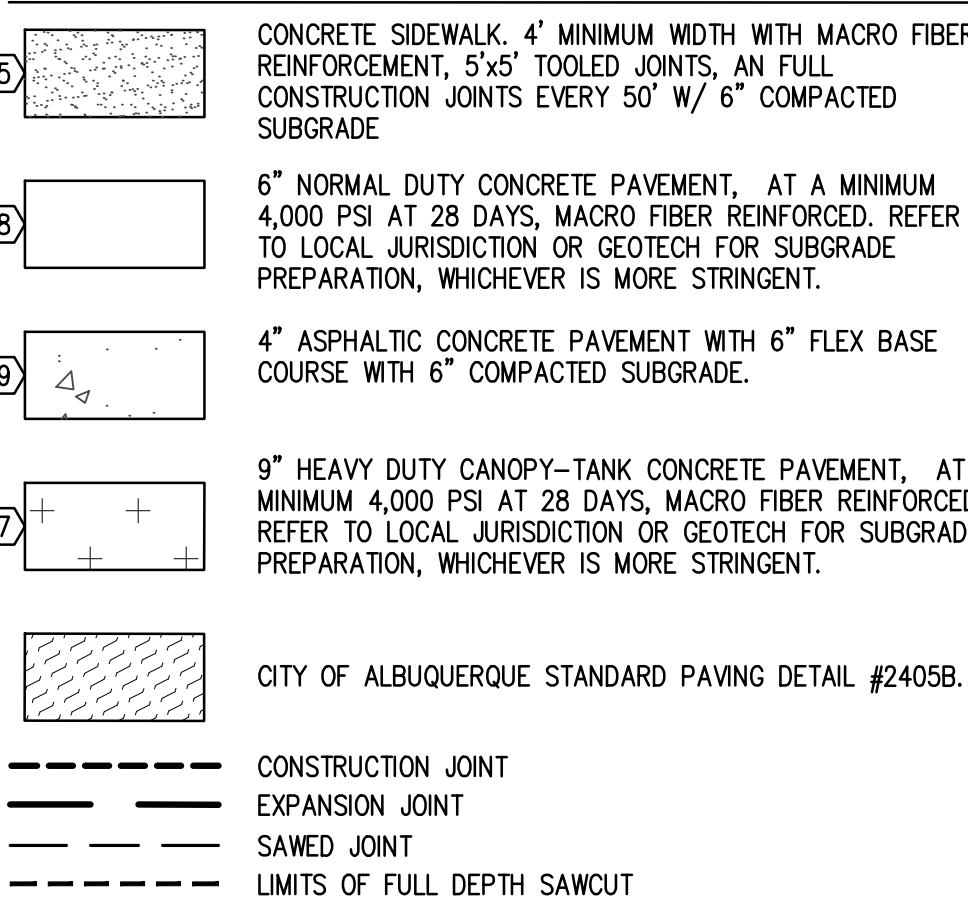

**EXISTING LEGEND:**

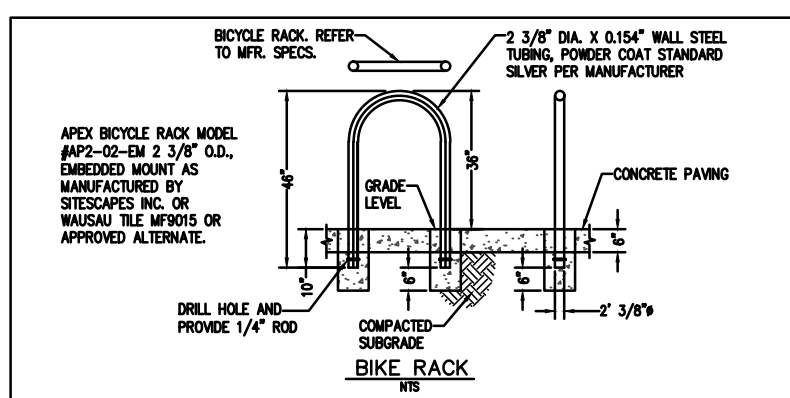
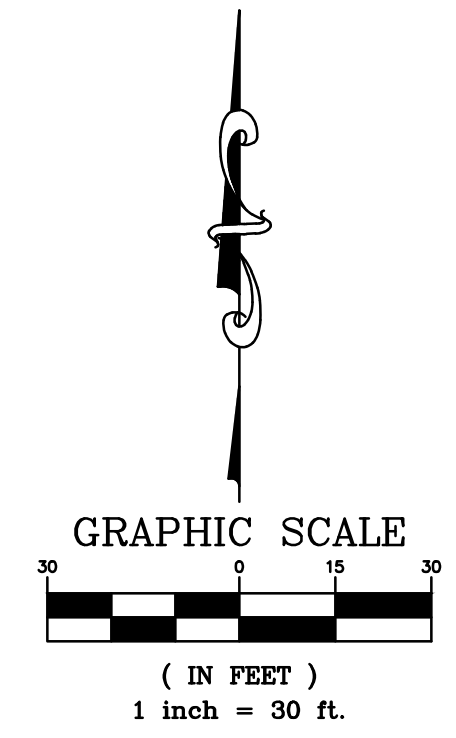
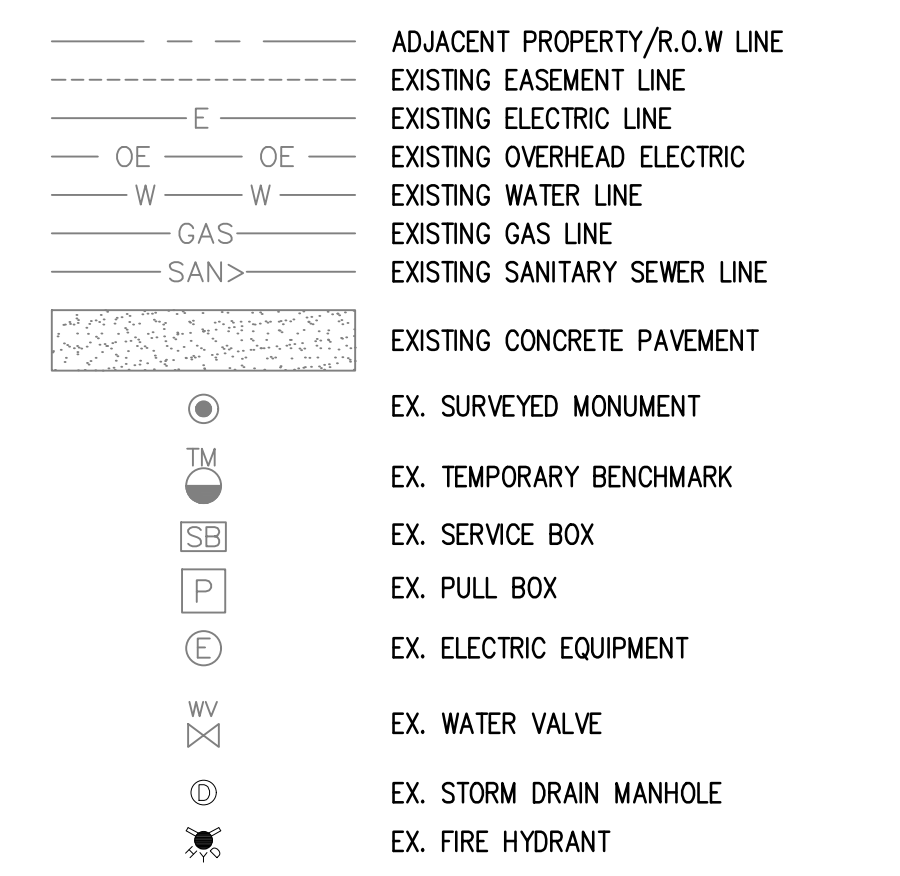

**TRAFFIC CIRCULATION LAYOUT (TCL)**  
 CIRCLE K, INC  
 LOT 1A, SNOW VISTA INVESTORS  
 9800 DE VARGAS RD.  
 ALBUQUERQUE, NEW MEXICO 87121

PROJECT NO.	DATE	DESCRIPTION
JM-DW25001	11/17/25	INITIAL SUBMITTAL
	12/18/25	2ND SUBMITTAL

NAME	DATE	REVISION
CSK		
CPK		

PROJECT NO.	DRAWN BY	CHECKED BY	DATE
JM-DW25001	ASR, JK, GPK	ASR, JK, GPK	03/09/2026

**C 800**

J:\CIRCLE K\DW25001 98TH DE VARGAS RD - ALBUQUERQUE, NM\_CURRENT DRAWINGS\JM-DW25001 - 98TH & DE VARGAS, ALBUQUERQUE, NM - 24X36 MASTER.DWG 3/9/2026 2:20 PM JOSEPH KIFFE