

REVISIONS

1	3/12/2021	ADDENDUM 002
2		
3		
4		

DRAWN BY	A. SANTI
REVIEWED BY	G. EVERETT
DATE	02/25/2021
PROJECT NO.	20-0023
DRAWING NAME	

SITE DETAILS

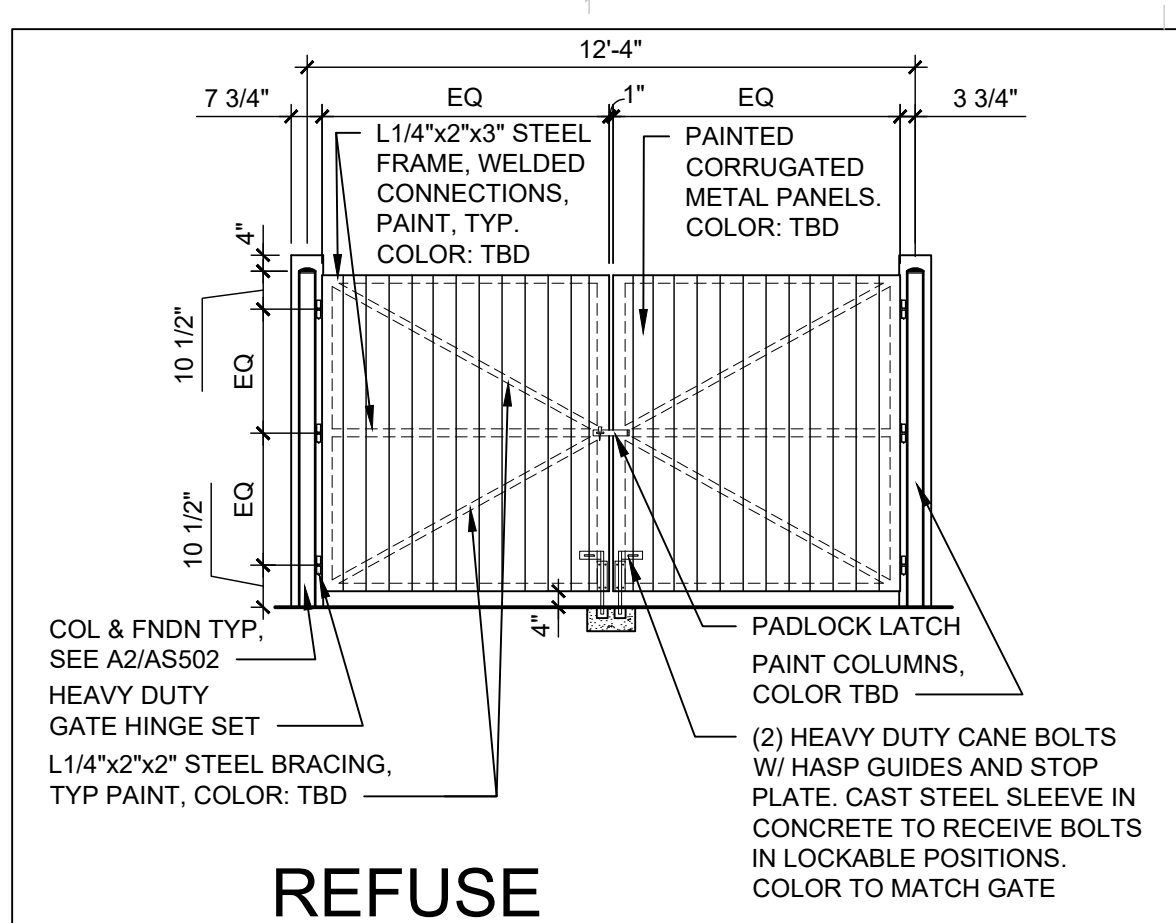

D1 REFUSE ENCLOSURE GATE
1/4" = 1'-0"

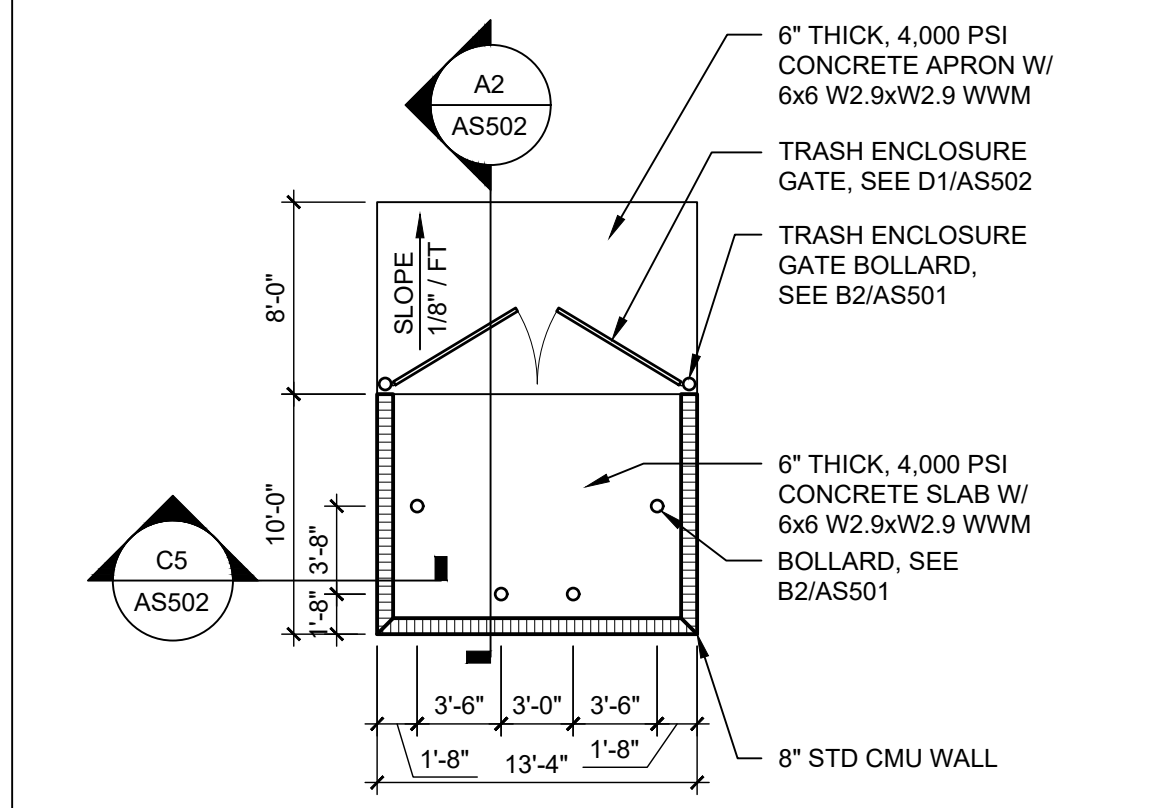

C1 TRASH ENCLOSURE
1/8" = 1'-0"

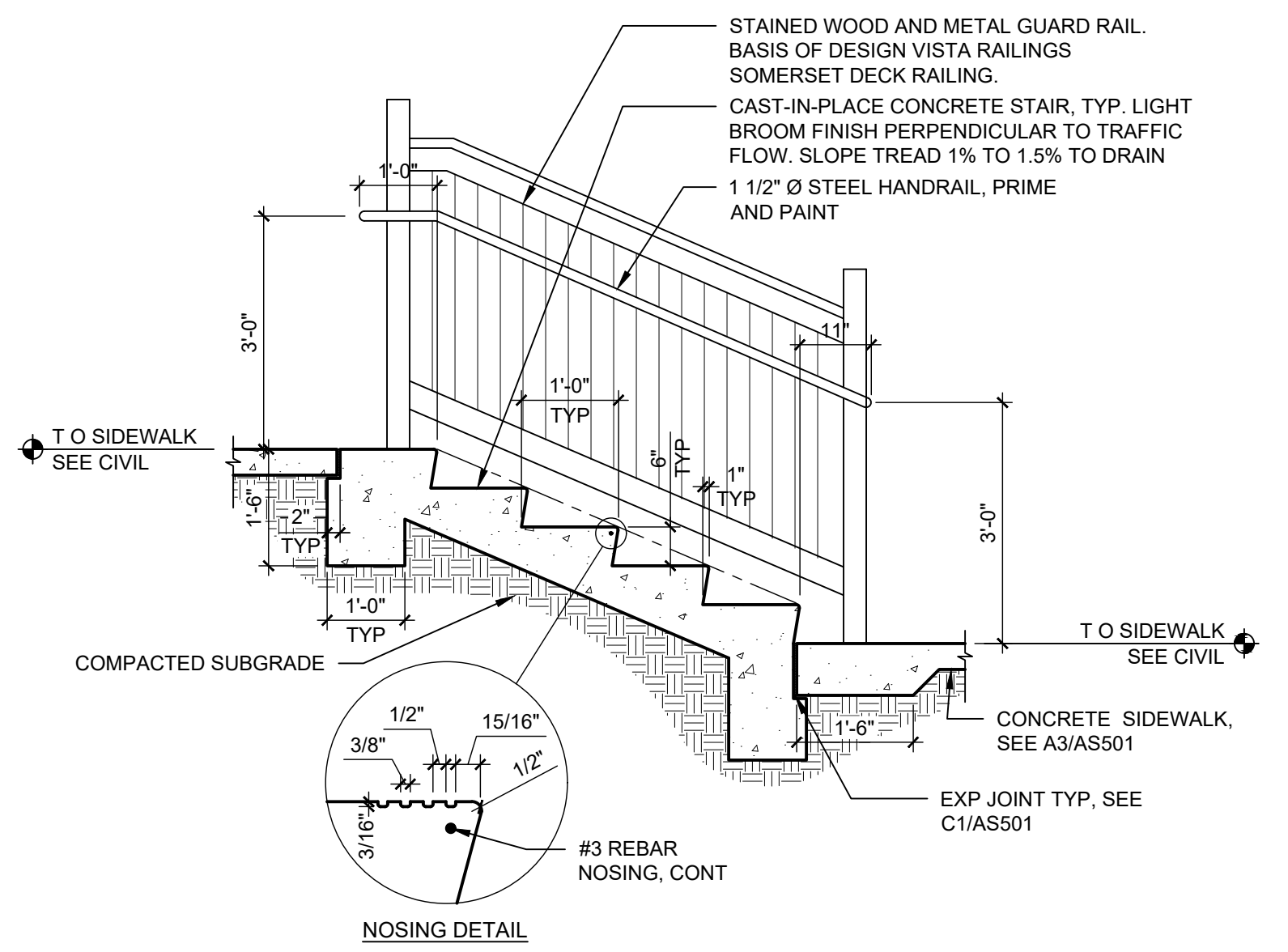

C2 STANDARD STAIR
1/2" = 1'-0"

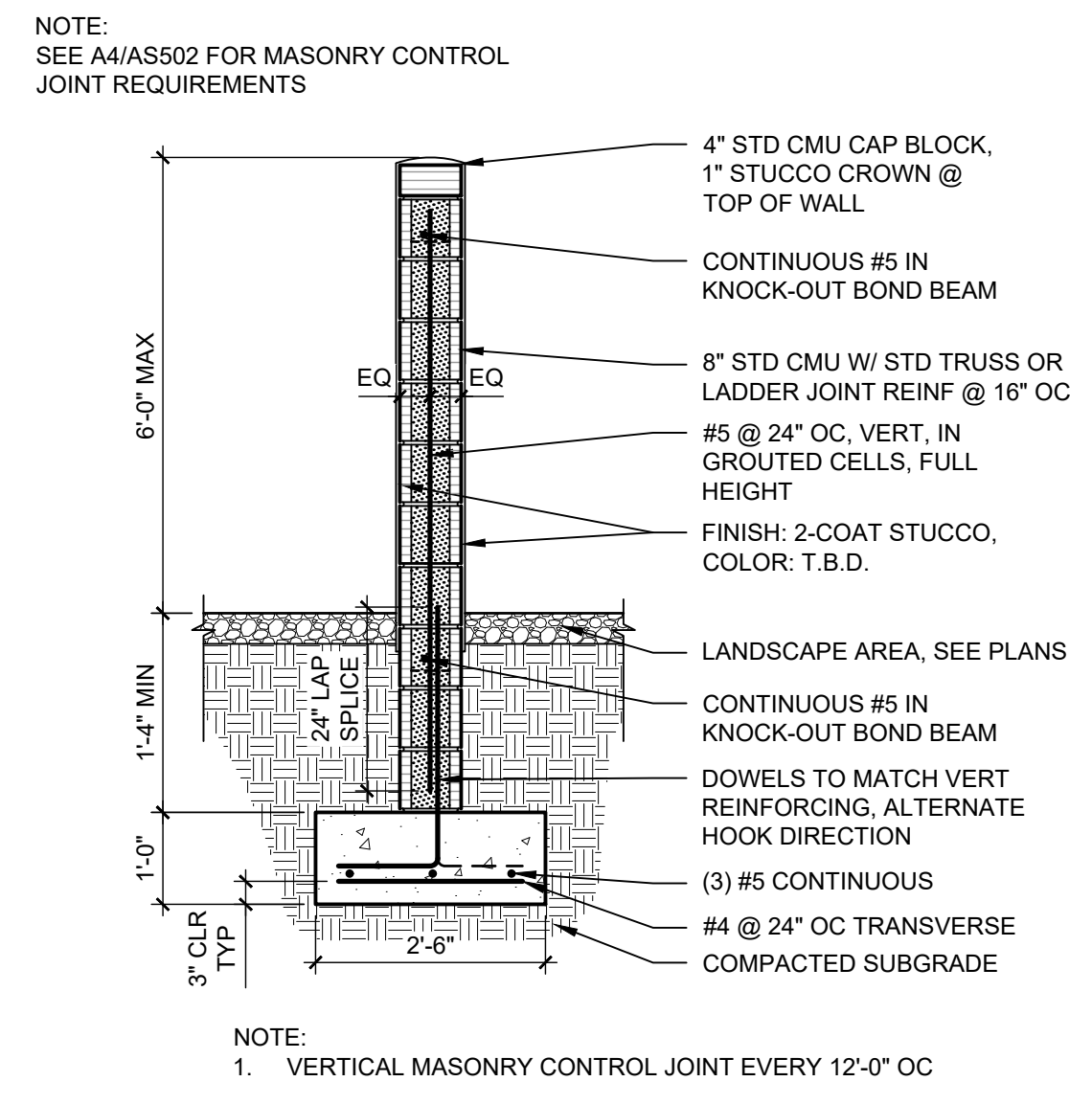

C4 6' CMU SCREEN WALL
1/2" = 1'-0"

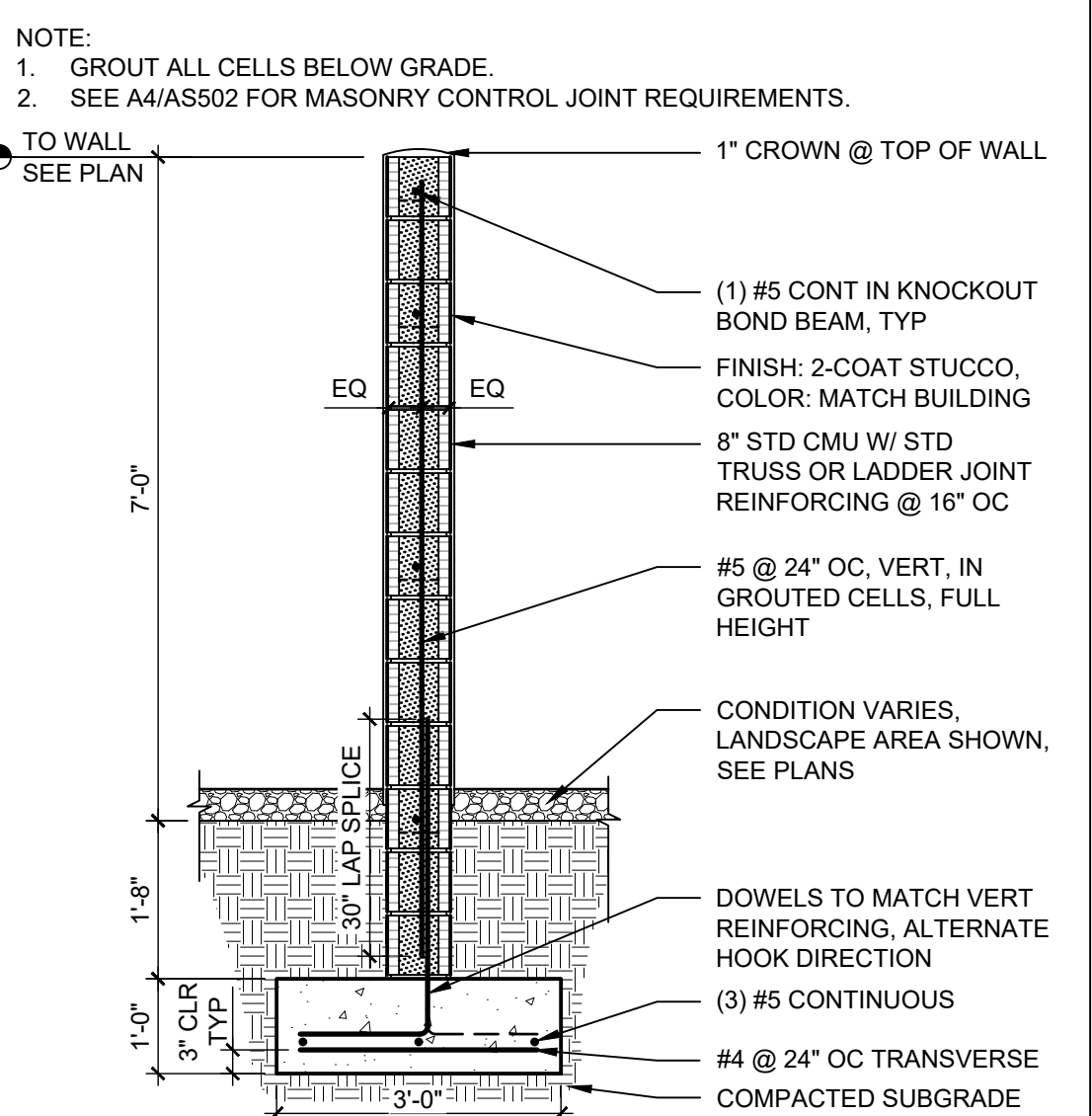

C5 7' CMU SCREEN WALL
1/2" = 1'-0"

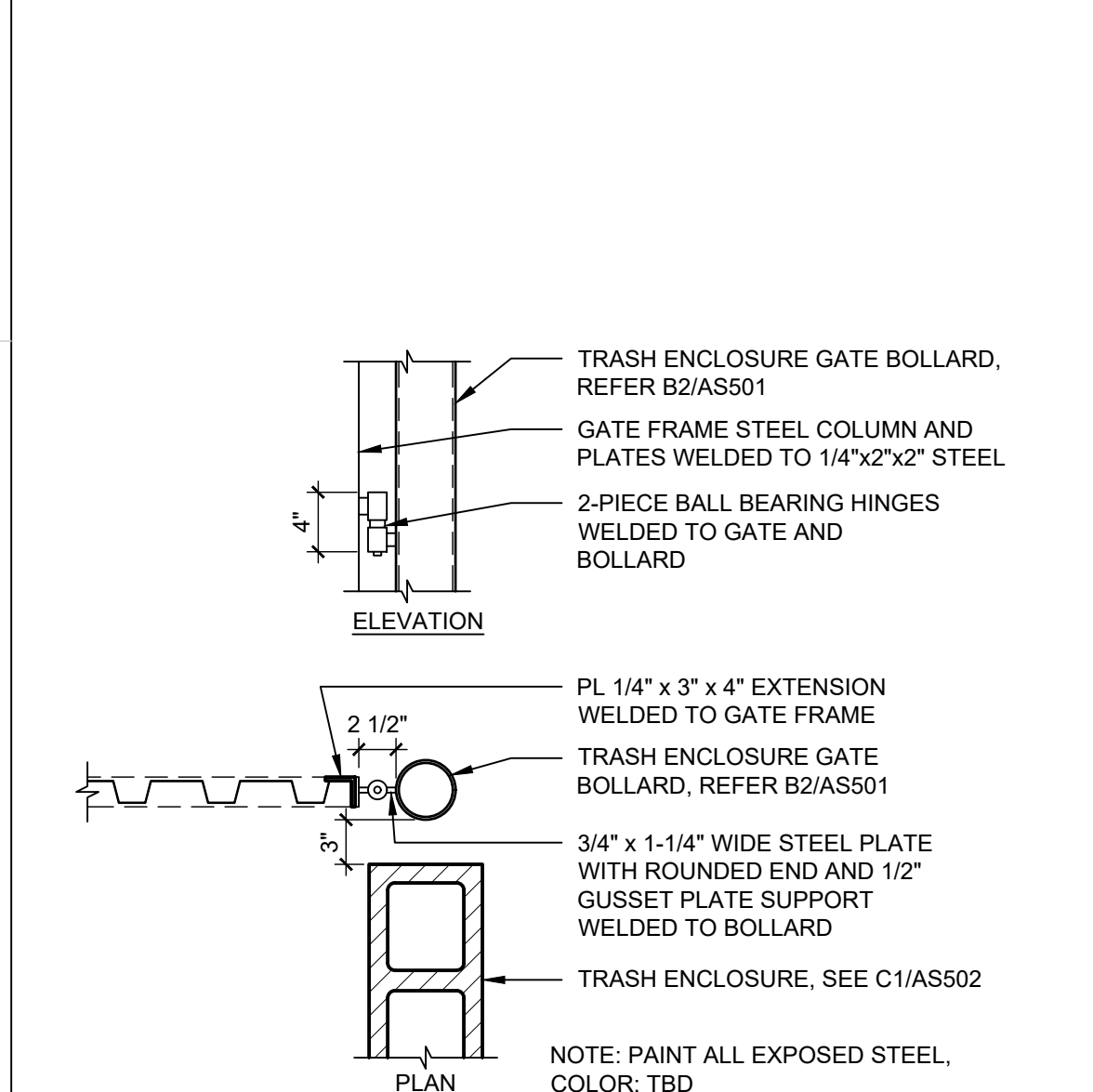

A1 BOLLARD CONNECTION @ TRASH ENCLOSURE GATE
1" = 1'-0"

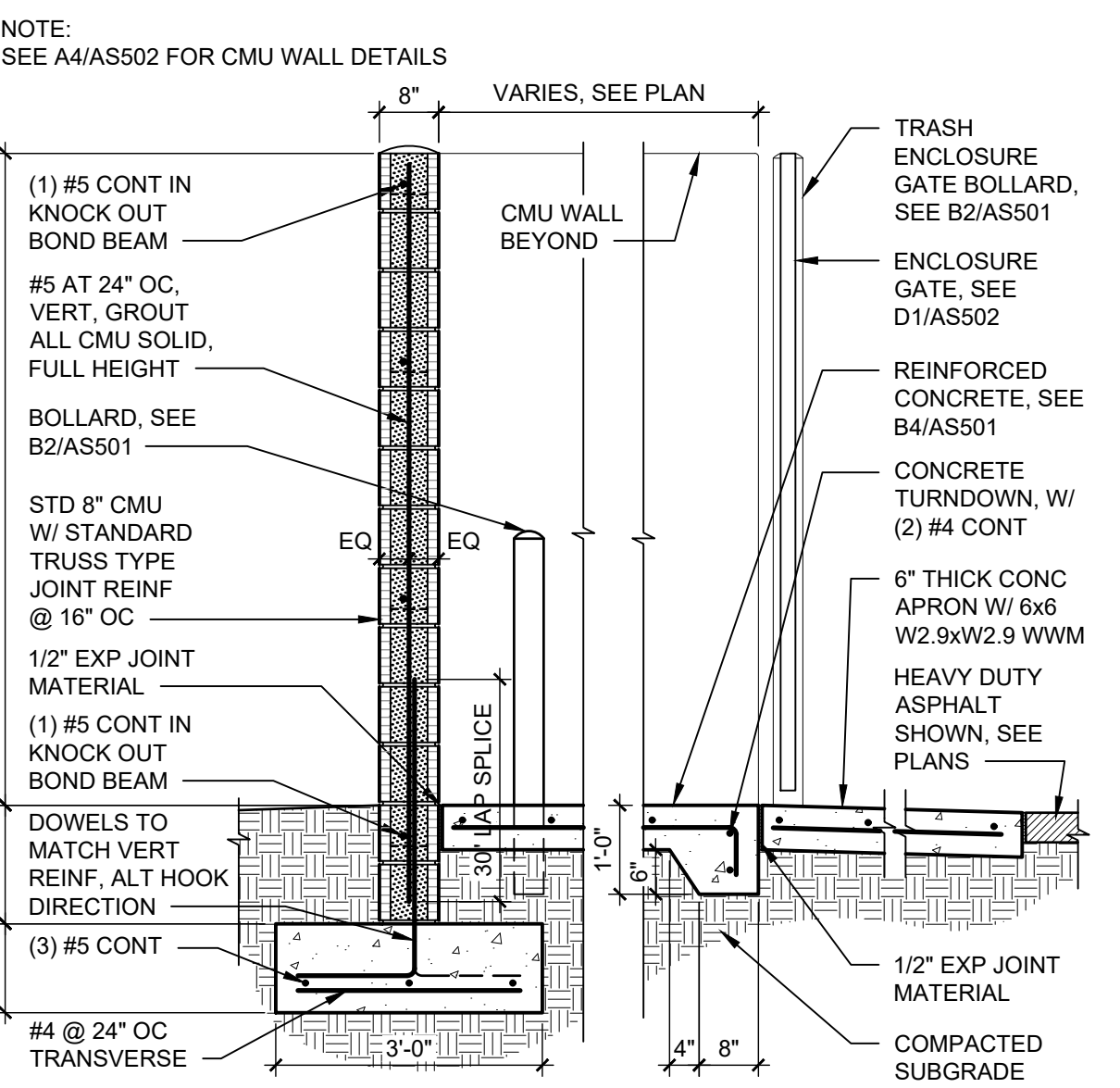

A2 TRASH ENCLOSURE CMU WALL AND GATE
1/2" = 1'-0"

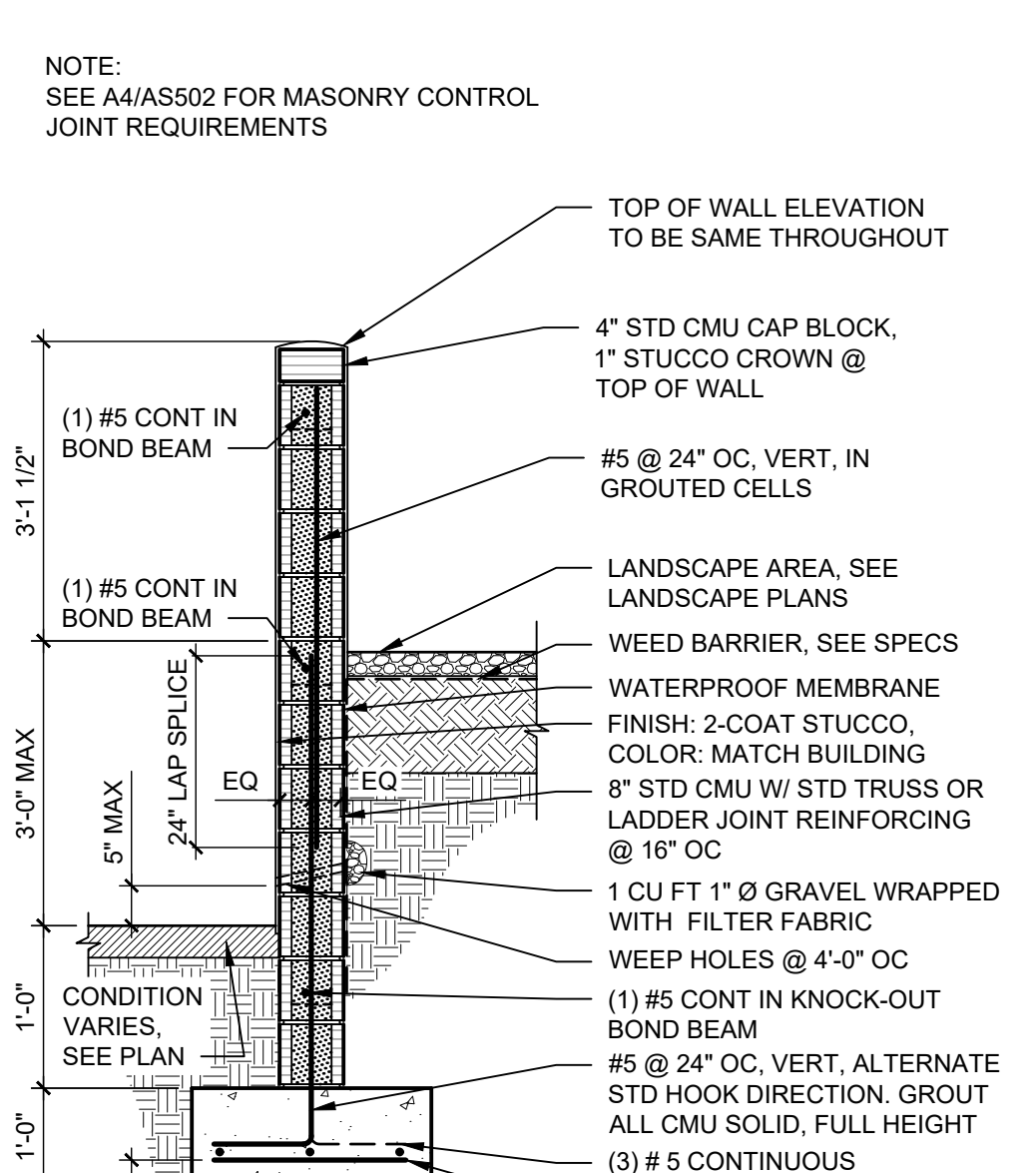

A3 CMU RETAINING WALL
1/2" = 1'-0"

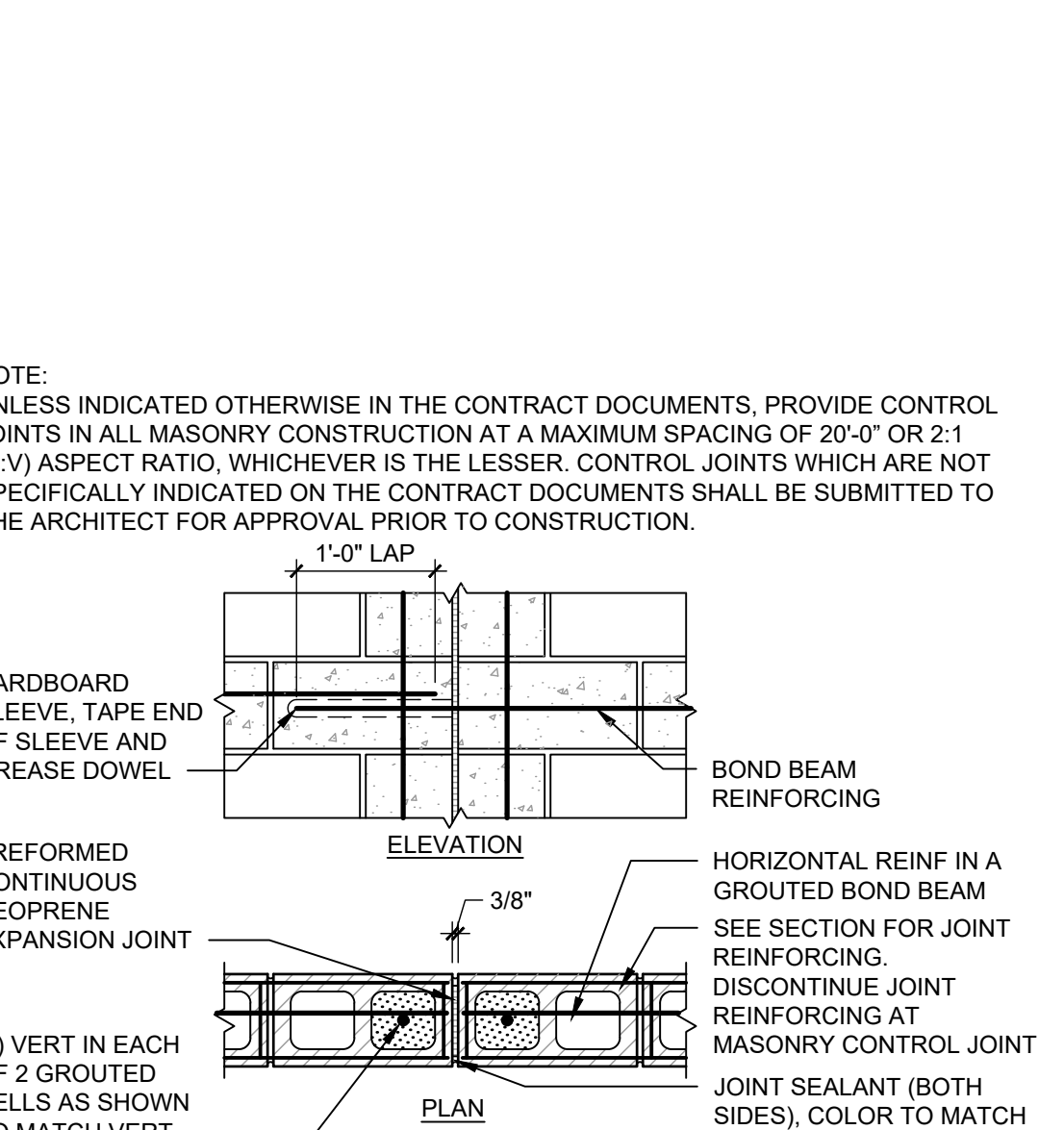

A4 MASONRY CONTROL JOINT
3/4" = 1'-0"

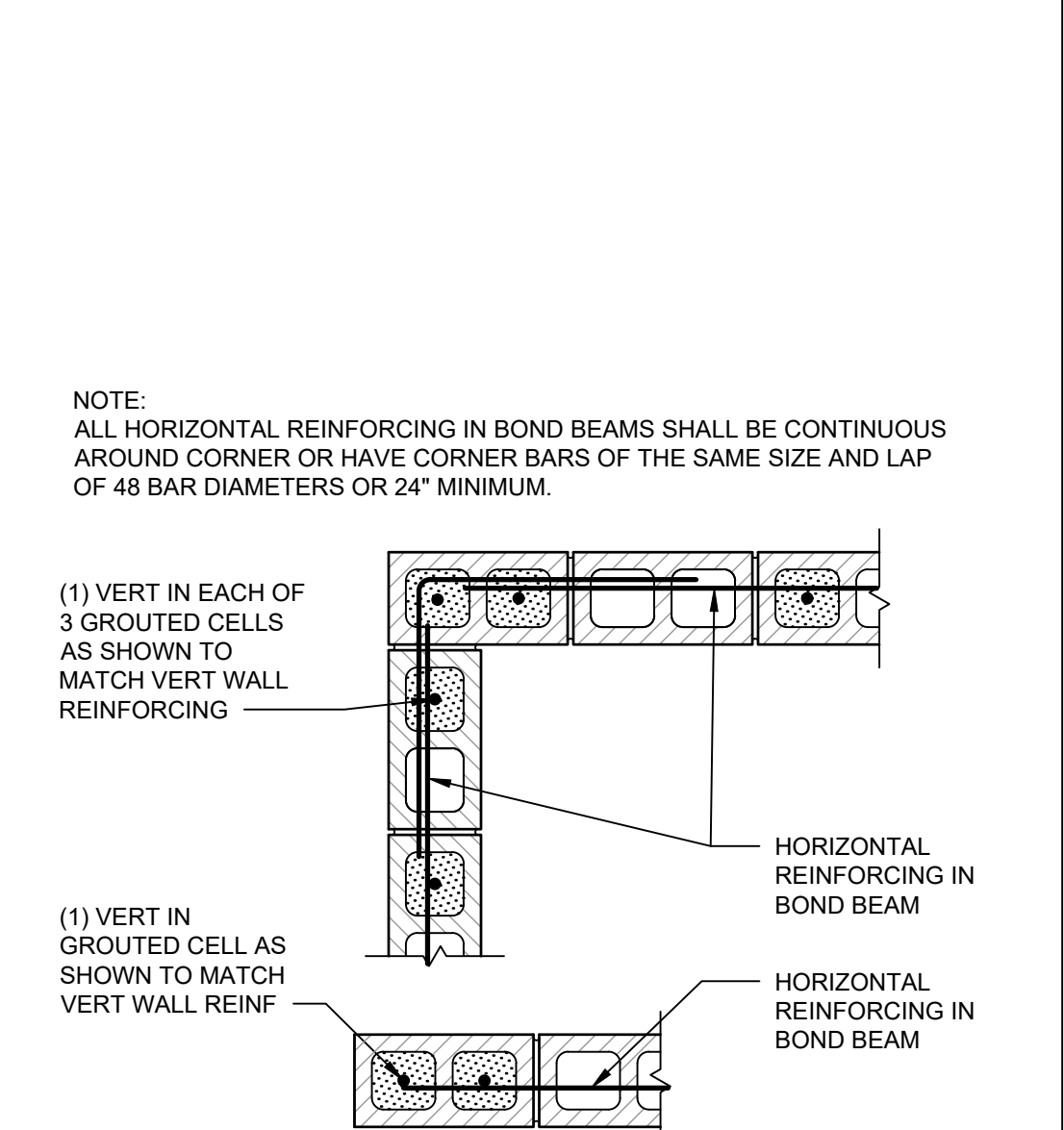

A5 8' CMU WALL END & CORNER DETAILS
3/4" = 1'-0"