

**ADMINISTRATIVE AMENDMENT**

**FILE # \_\_\_\_\_ PROJECT # \_\_\_\_\_**

\_\_\_\_\_

\_\_\_\_\_

\_\_\_\_\_

**APPROVED BY**

**DATE**

May 10, 2021

**LANDSCAPE LEGEND**

Note: Plants extended by SF ea, SF Total  
Separate totals for Shrub and Tree

QTY	SIZE	COMMON/BOTANICAL	HxS	SF/EA	SF/TOTAL	W/O USE
2	6" B"	Austrian Pine <i>Pinus nigra</i>	35x25	675	1250	M
1	15 Gal	Crape Myrtle <i>Lagerstroemia indica</i>	15x20	400	400	M
4	15 Gal	Oklahoma Redbud <i>Cercis reniformis</i>	15x12	144	576	M
11	15 Gal	Desert Willow <i>Chilopsis linearis</i>	20x20	400	4400	M
<b>Shrubs &amp; Groundcovers</b>						
31	5 Gal	India Hawthorne <i>Raphiolepis indica</i>	3x5	25	775	M
3	5 Gal	Karl Foerster Grass <i>Calamagrostis acutiflora</i> 'Karl Foerster'	2.5x3	9	27	M
5	5 Gal	Deep Blue Lavender <i>Lavender angustifolia</i> 'Hidcote'	2x3	9	45	M
2	5 Gal	Butterfly Bush <i>Buddleia davidii</i>	5x1	49	98	M
10	5 Gal	Buffalo Juniper <i>Juniperus sabina</i> 'Buffalo'	1x12	144	1440	M
16	5 Gal	Cherry Sage <i>Salvia greggii</i>	2x3	9	144	M
10	5 Gal	Blue Mist <i>Caryopteris x clandonensis</i>	3x3	9	90	M
3	5 Gal	Fern Bush <i>Chamaebatiaria millefolium</i>	5x6	36	108	L
9	5 Gal	Apache Plume <i>Falugia paradoxa</i>	6x1	49	441	L
12	5 Gal	Chamisa <i>Chrysothamnus nauseosus</i>	5x1	25	300	L
8	2-3cf	Boulders To be placed at contractor discretion			3468	
6680		Landscape Gravel / Filter Fabric Mountainair Brown				

LANDSCAPE NOTES:  
Landscape maintenance shall be the responsibility of the Property Owner. The Property Owner shall maintain all landscaping in a living, healthy, and attractive condition.

Water management is the sole responsibility of the Property Owner. All landscaping shall comply with the City of Albuquerque Zoning Code. In general, water conservative, environmentally sound landscape principles will be followed in design and installation.

Landscape gravel over Filter Fabric to a minimum depth of 3" shall be placed in all landscape areas.

IRRIGATION NOTES:  
Irrigation system maintenance and operation shall be the sole responsibility of the owner. It shall be the owners responsibility to ensure that fugitive water does not leave the site due to overwatering.

Irrigation shall be a complete underground system with Trees to receive 1 Netafim spiral (50' length) with 3 loops at a final radius of 4.5' from tree trunk, pined in place. Netafim shall have emitters 12" o.c. with a flow of 6 gph. Shrubs to receive (2) 10 GPH Drip Emitters. Drip and Bubblers systems to be tied to 1/2" poly pipe with flush caps at each end.

Run time per each shrub drip valve will be approximately 15 minutes per day. Tree drip valve shall run 15 hours, 3 times per week. Run time will be adjusted according to the season.

Point of connection for irrigation system is unknown at current time and will be coordinated in the field. Irrigation will be operated by automatic controller.

Location of controller to be field determined and power source for controller to be provided by others.

Irrigation maintenance shall be the responsibility of the Property Owner.

Water and Power source shall be the responsibility of the Developer/Builder.

**LANDSCAPE CALCULATIONS**

TOTAL LOT AREA (sf)	31481
TOTAL BUILDING AREA (sf) (Foot Print)	-6480
TOTAL LOT AREA (sf)	25001
LANDSCAPE REQUIREMENT (15%)	X .15
TOTAL LANDSCAPE REQUIRED (15%)	3750 SF
TOTAL ON-SITE LANDSCAPE PROVIDED	6680 SF
TOTAL LIVE PLANTS REQUIRED	5010 SF
TOTAL LIVE PLANTS PROVIDED	10094 SF

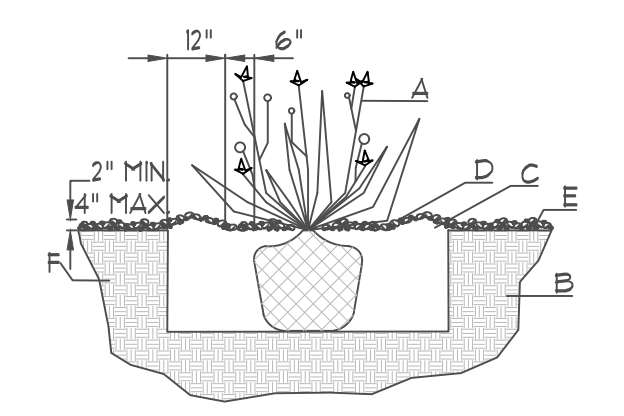

**SHRUB PLANTING DETAIL**

NTS  
GENERAL NOTES:  
1. THE OUTSIDE DIAMETER OF THE WATER RETENTION BASIN SHALL BE TWICE THE DIAMETER OF THE SHRUB PLANTING PIT.  
CONSTRUCTION NOTES:  
A. SHRUB.  
B. BACKFILL WITH EXISTING SOIL.  
C. EARTH BERM AROUND WATER RETENTION BASIN.  
D. 3" DEPTH OF GRAVEL MULCH.  
E. FINISH GRADE.  
F. UNDISTURBED SOIL.

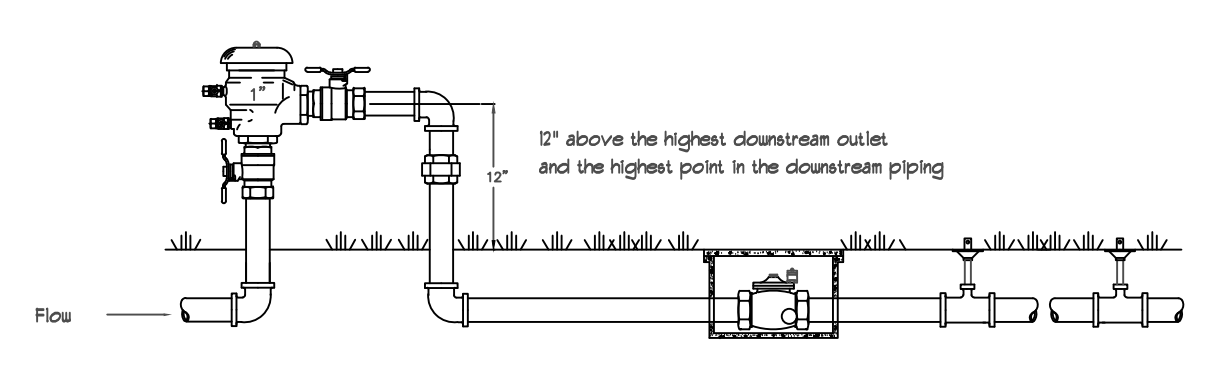

**FEBCO MODEL 765**

Pressure Vacuum Breaker  
Outside Installation

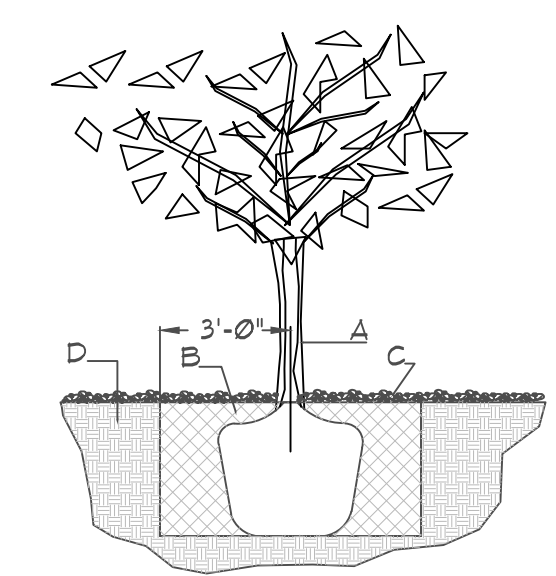

**TREE PLANTING DETAIL**

NTS  
GENERAL NOTES:  
1. ROOTBALL SHALL BE PLACED ON UNDISTURBED SOIL TO PREVENT TREE FROM SETTLING.  
2. TOP OF ROOTBALL INDICATED LEVEL AT WHICH TREE WAS GROWN AND DUG; THIS REPRESENTS THE LEVEL AT WHICH THE TREE SHOULD BE INSTALLED; THAT LEVEL MAY BE EXCEEDED BY ONLY A ONE INCH LAYER OF SOIL.  
3. PRIOR TO BACKFILLING TREE, ALL WIRE, ROPE AND SYNTHETIC MATERIALS SHALL BE REMOVED FROM THE TREE AND THE PLANTING PIT.  
4. PRIOR TO BACKFILLING ALL BURLAP SHALL BE CUT AWAY EXCEPT FROM BOTTOM OF THE ROOTBALL.  
CONSTRUCTION NOTES:  
A. TREE  
B. BACKFILL WITH EXISTING SOIL.  
C. 3" DEPTH OF GRAVEL MULCH.  
D. UNDISTURBED SOIL.

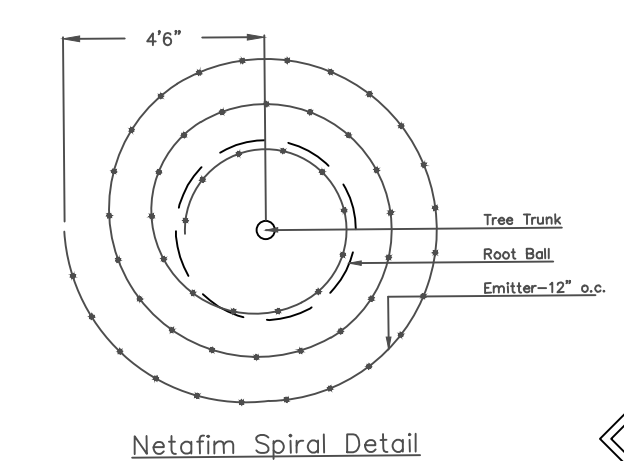

Netafim Spiral Detail

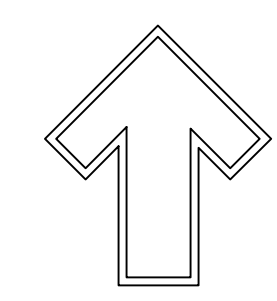

**GRAPHIC SCALE**



SCALE: 1" = 20'-0"

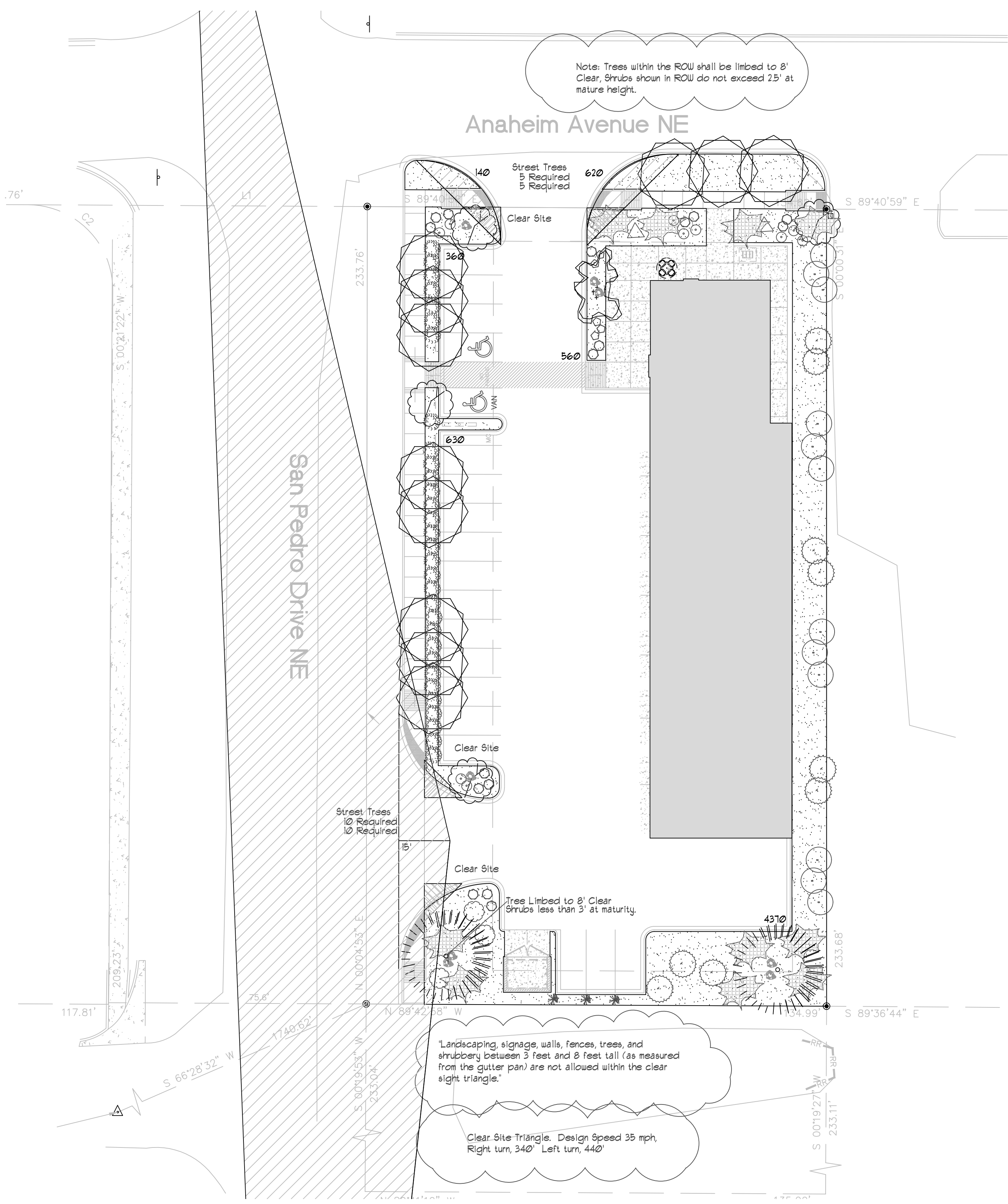

Note: Trees within the ROW shall be limbed to 8' Clear. Shrubs shown in ROW do not exceed 25' at mature height.

Street Trees 5 Required  
Clear Site

Street Trees 10 Required  
Clear Site

Tree Limbed to 8' Clear  
Shrubs less than 3' at maturity.

Landscaping, signage, walls, fences, trees, and shrubbery between 3 feet and 8 feet tall (as measured from the gutter pan) are not allowed within the clear sight triangle.

Clear Site Triangle. Design Speed 35 mph, Right turn, 340'. Left turn, 440'.

**Horizon Glass**  
**8510 San Pedro Dr. NE**  
**Albuquerque, NM 87115**

DESIGNED BY: ID: Mitchell  
DRAWN BY: dm  
APPROVED BY: [Signature]  
DATE: April 15, 2021

REVISIONS  
Date: April 15, 2021  
Comment

Seal:  
Landscape Architect  
STATE OF NEW MEXICO  
DANNY D. MITCHELL  
239  
REGISTERED  
LANDSCAPE ARCHITECT  
May 10, 2021  
DRAWING NO:  
**LS-101**