



# Mark Armijo ACADEMY

# MARK ARMIJO ACADEMY PORTABLE RELOCATION

## CONSTRUCTION DOCUMENT SET

MAY 17, 2021

### SHEET INDEX:

#### GENERAL

G-000 Cover Sheet

#### CIVIL

C-100 HYDROLOGY  
C-101 GRADING AND DRAINAGE  
AS-101 SITE PLAN

#### STRUCTURAL

SKS-001 PORTABLE FOUNDATION PLAN  
SKS-002 FOOTING DETAILS

#### ELECTRICAL

E-001 ELECTRICAL LEGEND  
ES-101 ELECTRICAL SITE PLAN  
E-601 ELECTRICAL DIAGRAMS

#### SCOPE OF WORK:

Project scope of work to include the placement of portable classroom building located on the south western portion of the campus. Scope to include the construction of foundations, utility connections, and site work around the portable location as shown within the drawings.

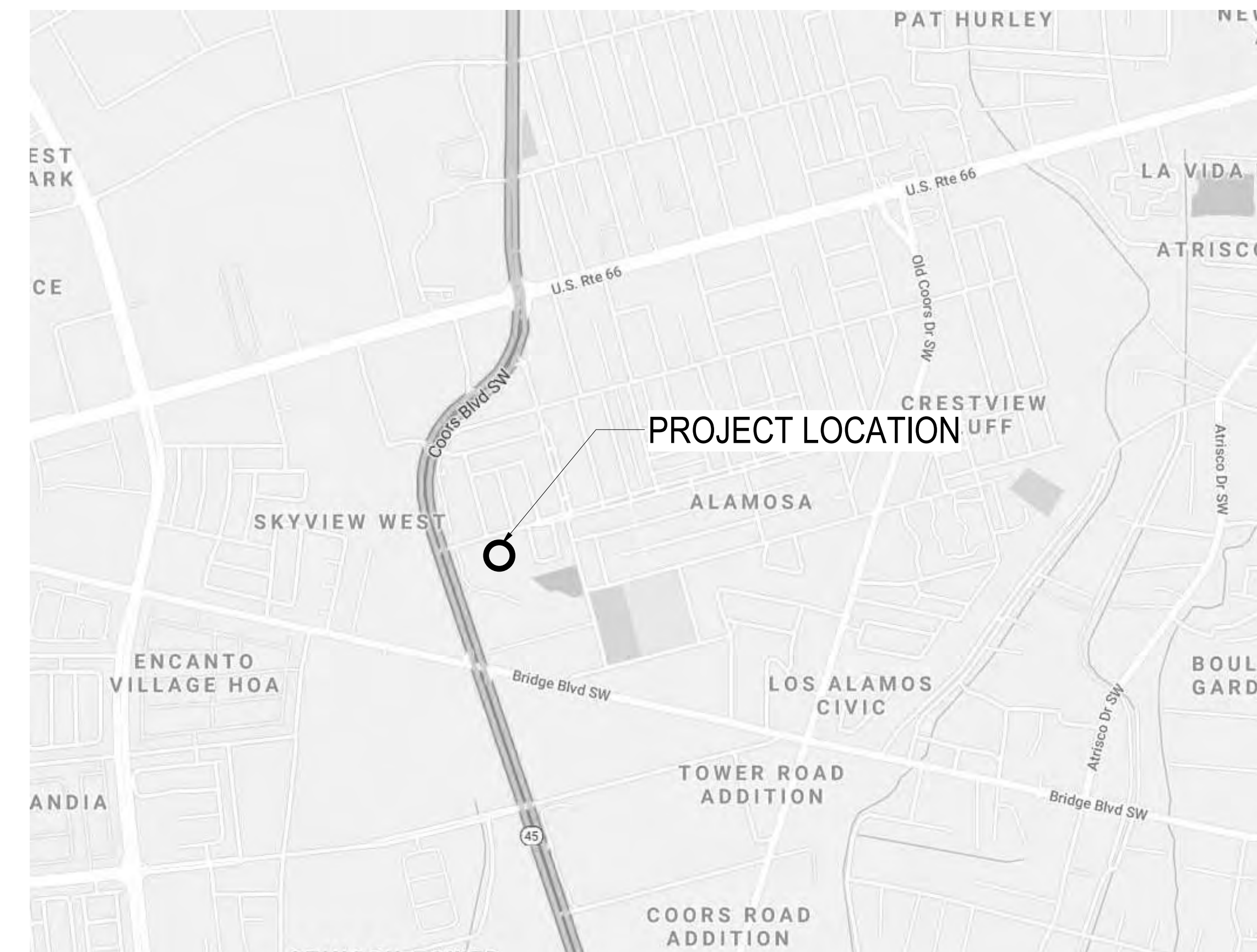

VICINITY MAP

6800 Gonzales Rd SW  
Albuquerque, NM 87121

#### OWNER

Mark Armijo Academy  
6800 Gonzales Rd. SW  
Albuquerque, NM 87121  
p\_505.873.7758

#### CONSULTANTS

**CIVIL**  
Miller Engineering Consultants  
3500 Comanche NE, Bldg F  
Albuquerque, New Mexico 87107  
p\_505.888.7500

**STRUCTURAL**  
Walla Engineering Ltd  
6501 Americas Pkwy NE Ste. 302  
Albuquerque, NM 87110  
p\_505.881.3008

**M/E/P/F/P**  
Bridgers and Paxton  
4600-C Montgomery Blvd. NE  
Albuquerque, New Mexico 87109  
p\_505.883.4111 f\_505.888.1436

fbt | architects

MAIL: 6501 Americas Pkwy NE Ste. 300  
Albuquerque, NM 87110  
p\_505.883.5200 www.fbtarch.com



ARCHITECT

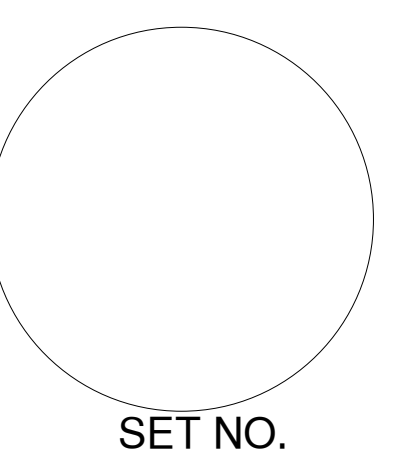

SET NO.

## DRAINAGE REPORT

### GENERAL NOTES:

1. EXISTING TOPOGRAPHIC SURVEY PERFORMED AND COMPILED BY TERRA LAND SURVEYS, LLC, CORRALES, NEW MEXICO APRIL 2020. MILLER ENGINEERING CONSULTANTS HAS UNDERTAKEN NO FIELD VERIFICATION OF THIS INFORMATION.
2. PROJECT BENCHMARK IS A CITY OF ALBUQUERQUE SURVEY BRASS DISC STAMPED "ACS BM 11-K10", TO REACH THE BENCHMARK FROM THE INTERSECTION OF CENTRAL AVENUE AND COORS BLVD. S.W., TRAVEL SOUTH ON COORS BLVD. 0.55 MILES TO THE INTERSECTION WITH GONZALES ROAD S.W. EPOXIED TO TOP OF S.S.E. CONCRETE CURB RETURN OF THE INTERSECTION. ELEVATION = 5,046.07 FEET (NAVD 1988 VERTICAL DATUM)
3. THE CONTRACTOR IS RESPONSIBLE FOR ALL TEMPORARY SEDIMENT AND EROSION CONTROL DEVICES DURING THE CONSTRUCTION PHASE.
4. CONTRACTOR SHALL OBTAIN A GRADING PERMIT FROM THE CITY OF ALBUQUERQUE, PRIOR TO ANY GRADING OR CONSTRUCTION.
5. TWO WORKING DAYS PRIOR TO ANY EXCAVATION CONTRACTOR MUST CONTACT LINE LOCATING SERVICE 260-1990 FOR LOCATION OF EXISTING UTILITIES.
6. ALL EMBANKMENTS SHALL BE PLACED AND COMPACTED IN LIFTS OF MAXIMUM OF 8". THE EMBANKMENTS SHALL BE WETTED AND COMPACTED TO 95% OPTIMUM DENSITY PER ASTM D1557 AND 95% UNDER ALL STRUCTURES INCLUDING DRIVEWAYS AND PARKING LOTS.
7. THE CONTRACTOR SHALL FIELD VERIFY LOCATION AND SIZE OF ALL UTILITIES PRIOR TO CONSTRUCTION.
8. ALL WORK PERFORMED SHALL COMPLY WITH THE REQUIREMENTS OF THE CITY OF ALBUQUERQUE STORM DRAINAGE REGULATIONS. ALL WORK PERFORMED SHALL COMPLY WITH THE REQUIREMENTS OF THE CITY OF ALBUQUERQUE "GRADING AND DRAINAGE DESIGN REQUIREMENTS AND POLICIES FOR LAND DEVELOPMENT."
9. THE OWNER, CONTRACTOR AND/OR BUILDER SHALL COMPLY WITH ALL APPROPRIATE LOCAL, STATE AND FEDERAL REGULATIONS AND REQUIREMENTS.
10. THE CONTRACTOR SHALL TAKE ALL APPROPRIATE AND REASONABLE MEASURES TO PREVENT SEDIMENT OR POLLUTANT LADEN STORM WATER FROM EXITING THE SITE DURING CONSTRUCTION. STORMWATER MAY BE DISCHARGED IN A MANNER, WHICH COMPLIES WITH THE APPROVED GRADING AND DRAINAGE PLAN.
11. THE CONTRACTOR SHALL TAKE ALL APPROPRIATE MEASURES TO PREVENT THE MOVEMENT OF CONSTRUCTION RELATED SEDIMENT, DUST, MUD, POLLUTANTS, DEBRIS, WASTE, ETC FROM THE SITE BY WIND, STORM FLOW OR ANY OTHER METHOD EXCLUDING THE INTENTIONAL, LEGAL TRANSPORTATION OF SAME IN A MANNER ACCEPTABLE BY THE CITY.
12. THE CONTRACTOR SHALL NOT DISTURB AREAS OUTSIDE THE AREAS SHOWN AS "SLOPE LIMITS" ON THE GRADING AND DRAINAGE PLAN.
13. SEE ARCHITECTURAL DRAWINGS FOR SIDEWALK AND HANDICAPPED RAMPS, DETAILS AROUND BUILDING.
14. THE CONTRACTOR SHALL CONTACT THE PROJECT ENGINEER FOR CLARIFICATION IF THERE ARE ANY SPOT ELEVATIONS ON THE GRADING AND DRAINAGE PLAN WHICH APPEAR TO BE AMBIGUOUS OR DO NOT MEET THE INTENT OF THE GRADING AND DRAINAGE PLAN.
15. THE CONTRACTOR SHALL CONTACT THE PROJECT ENGINEER FOR CLARIFICATION IF THERE ARE SIDEWALKS OR CONCRETE FLATWORK WHICH DOES NOT MEET ADA ACCESSIBILITY REQUIREMENTS. ALL SIDEWALKS SHALL HAVE A MAXIMUM CROSS SLOPE OF 2.0%, ALL SIDEWALKS SHALL HAVE A MAXIMUM LONGITUDINAL SLOPE OF 5.0%, AND ALL RAMPS SHALL HAVE A MAXIMUM LONGITUDINAL SLOPE OF 15:1.
16. ALL SIDEWALKS AND CONCRETE FLATWORK SHALL HAVE A MINIMUM OF 0.5% SLOPE. CONTRACTOR SHALL CONTACT PROJECT ENGINEER IF THERE ARE SIDEWALKS OR CONCRETE FLATWORK WHICH DO NOT MEET THIS REQUIREMENT.
17. THE CONTRACTOR SHALL SUBMIT MATERIAL SUBMITTALS, CUT SHEETS AND SHOP DRAWINGS FOR ALL CIVIL RELATED ITEMS FOR REVIEW PRIOR TO CONSTRUCTION.
18. THIS PROJECT SHALL BE CONSTRUCTED IN ACCORDANCE WITH THE 2014 EDITION OF THE NEW MEXICO STATE DEPARTMENT OF TRANSPORTATION STANDARD SPECIFICATIONS FOR HIGHWAY AND BRIDGE CONSTRUCTION (GREY BOOK).
19. ALL EXISTING MANHOLES, VALVES AND METERS SHALL BE ADJUSTED TO NEW FINISH GRADE.
20. THE CONTRACTOR SHALL SUBMIT A SEED MIX DESIGN TO THE OWNER FOR REVIEW AND APPROVAL PRIOR TO STARTING THE SEEDING ON THE PROJECT. THE SEED MIX DESIGN SHALL BE A SEED MIX RECOMMENDED BY NRCS FIELD OFFICE REPRESENTATIVE APPROPRIATE FOR PROJECT LOCATION.

ALL DISTURBED AREAS, NOT ADDRESSED BY ARCHITECTURAL LANDSCAPE PLAN WITH SLOPES OF LESS THAN 3:1 SHALL RECEIVE CLASS "A" SEEDING. ANY SLOPES THAT ARE 3:1 OR STEEPER SLOPES SHALL RECEIVE STEEP SLOPE SEEDING. THE STEEP SLOPE SEEDING SHALL CONSIST OF SEEDING IN CONJUNCTION WITH A 100% COCONUT FIBER BLEND EROSION BLANKET (NORTH AMERICAN GREEN C125) OR APPROVED EQUAL.

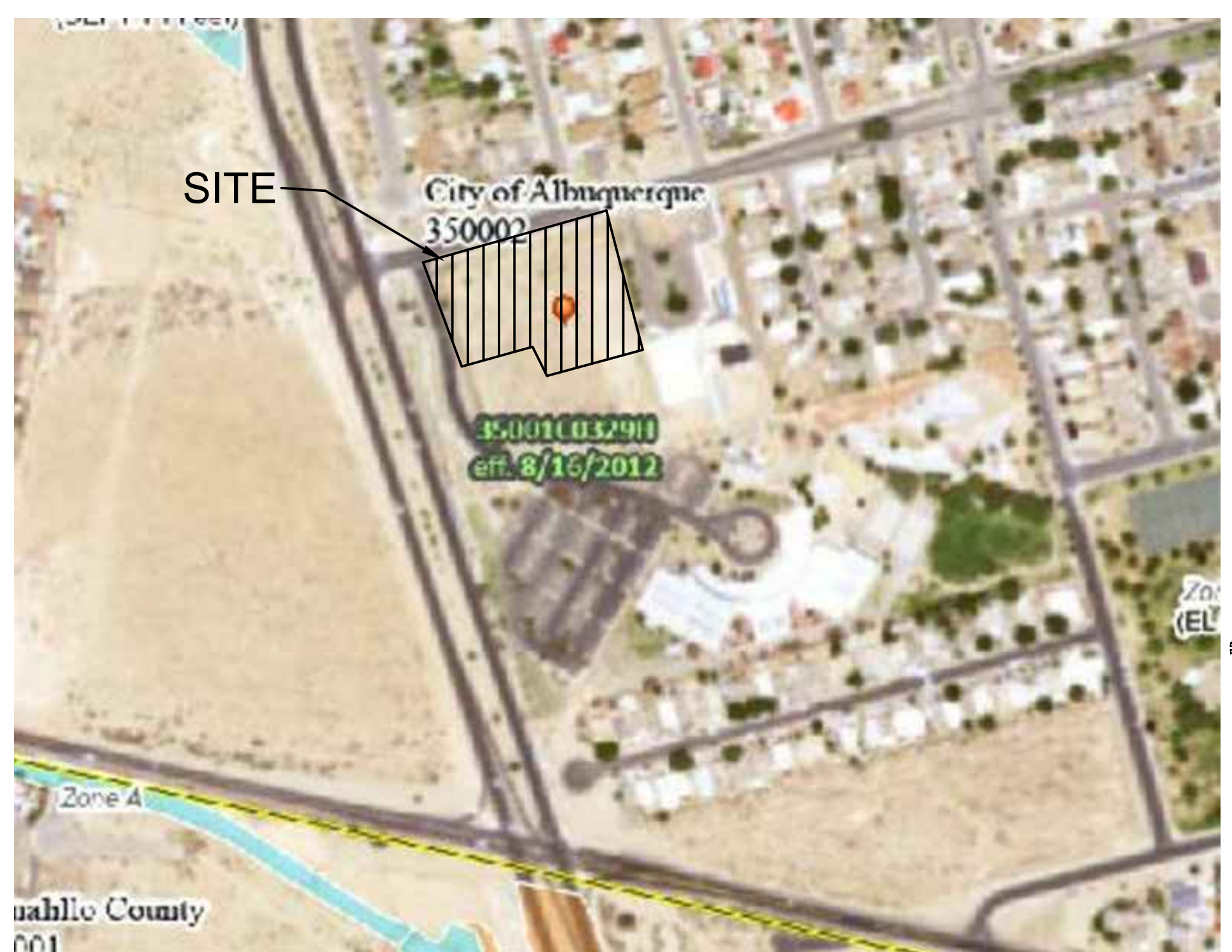

**FLOOD ZONE MAP**  
 FLOOD ZONE MAP 35001C0329H

### SITE LOCATION

The proposed project is located on approximately 3.3-acres of the campus of Mark Armijo Charter school. The overall site is estimated at 6 acres and can be accessed from Gonzales Road SW.

### EXISTING CONDITIONS

The overall existing site is estimated at 6 acres. The eastern 2.7 acres is currently partially developed with existing buildings and parking lot areas. There are two existing retention ponds that collect runoff from the eastern portion of this site. The pervious grading and drainage plan completed by Wooten Engineering in 2017 indicates that the two existing retention ponds can retain the 100-year, 10-day event. We have provided Sheet C-101 and C-102 prepared by Wooten Engineering as a part of this submittal for informational purposes only.

Based on the plan prepared by Wooten Engineering the western portion of the site to be developed under this project is called Basin C. For this submittal the site will be called Basin C to be consistent with the previously approved Wooten Plan.

Per the FMEA Panel on this sheet, the site does not lie within a 100-year FEMA floodplain and is not impacted by offsite flows.

### PROPOSED CONDITIONS

The proposed project would consist of a mass grading plan for the western portion of the site (Basin C). This phase will include mass grading of the site and the construction of a new retention pond (Pond C). The buildings, parking lots, playfield, and other improvements on the site are all improvement to be constructed in the future. Individual grading and drainage plans will be required for each future phase of development.

Basin C under future fully developed conditions will generate 0.594-acre feet during the 100-year, 10-day event. Pond C will be size to retain 100% of this volume. Pond C will be connected to existing Pond B with a 24" pipe. The existing emergency overflow spillway will be used for any overtopping flows from these ponds.

### CONCLUSIONS

When developed as indicated on the grading and drainage plan, the increased runoff from the site is estimated at 4.37 cfs, and 0.232 acre-feet during the 100-year, 24-hour event. The first flush pond volume required for the project estimated at 1975 cf. The proposed retention Pond C has a capacity of 0.720 acre-feet and is capable of retaining 100% of the 100-year, 10-day volume from Basin C.

## HYDROLOGY CALCULATIONS

HYDROLOGY										
Precipitation Zone 1 - 100-year Storm P(360) = 2.20 in P(1440) = 2.66 P(10 day) = 3.67										
Basin	Basin Area (Ac)	Land Treatment Factors				Ew (in)	V(100-6) (af)	V(100-24) (af)	V(100-10 day) (af)	Q(100) (cfs)
		A	B	C	D					
<b>Existing Conditions</b>										
C	3.40	1.70	0.00	1.50	0.20	0.77	0.219	0.227	0.243	7.37
<b>Total</b>	<b>3.40</b>									<b>7.37</b>
<b>Proposed Conditions</b>										
C	3.40	0.00	0.50	1.30	1.60	1.40	0.398	0.459	0.594	11.74
<b>Total</b>	<b>3.40</b>									<b>11.74</b>

## FIRST FLUSH CALCULATIONS

VFF = (69,696 SF \* 0.34" / 12)

VFF = 1,975 CF

VOLUME PROVIDED (AT 5031 TOP OF POND) = 0.720AF = 31,636.20 CF

## POND RATING CURVES

WATER HARVEST AREA				
Pond Rating Table				
Side Slope	3:1			
Depth (ft)	Area (sq ft)	Volume (ac-ft)	Cum Volume (ac-ft)	
5025	2856	0.066	0.000	0.000
5026	3537	0.081	0.073	0.073
5027	4290	0.098	0.090	0.163
5028	5117	0.117	0.108	0.271
5029	6010	0.138	0.128	0.399
5030	6987	0.160	0.149	0.548
5031	8021	0.184	0.172	0.720

top of pond



**VICINITY MAP**  
 ZONE ATLAS K-10-Z

### CONSULTANT

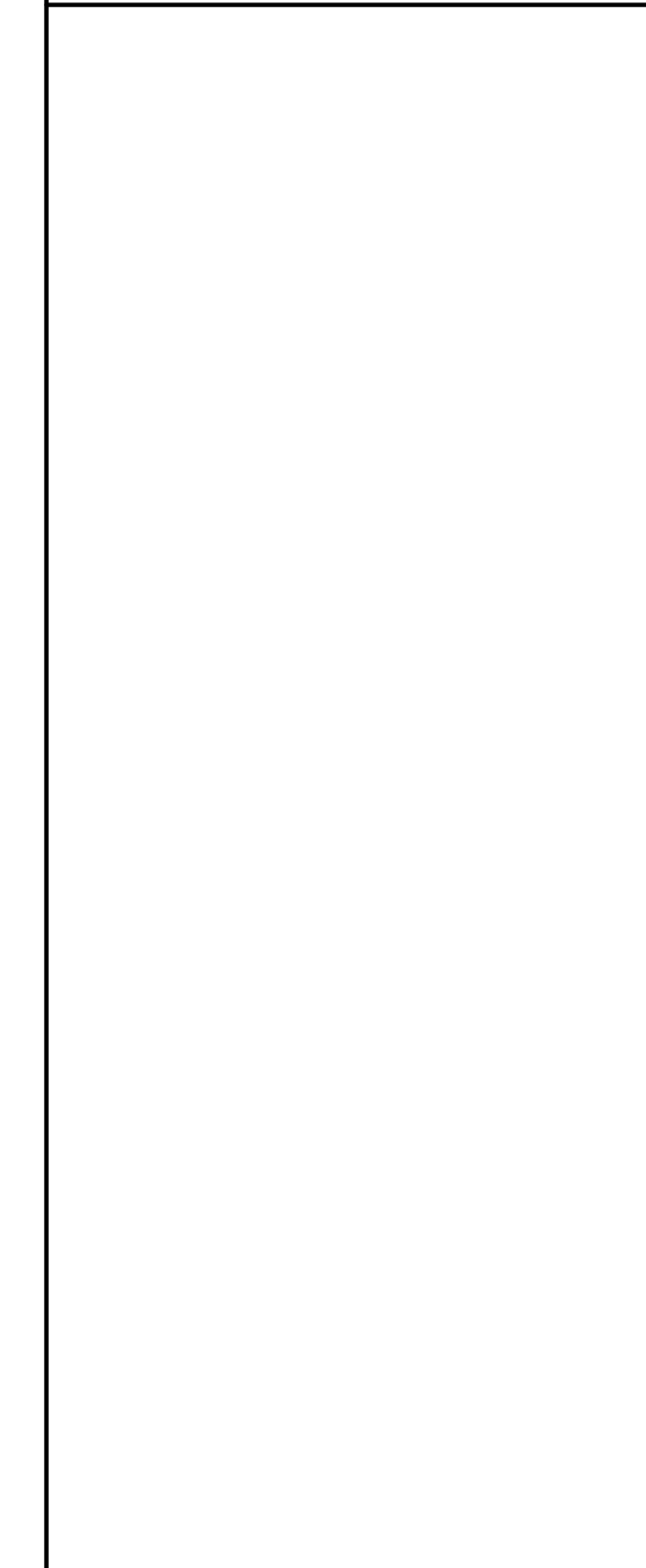

## Mark Armijo Academy - Master Plan

### Project Status

6800 Gonzales Rd SW  
 Albuquerque, NM 87121  
 NOVEMBER 2020

MARK	DATE	DESCRIPTION

ISSUE:	
DATE:	
PROJECT NO:	Project Number
CAD DWG FILE:	
DRAWN BY:	Author
CHECKED BY:	Checker

SHEET TITLE  
 HYDROLOGY

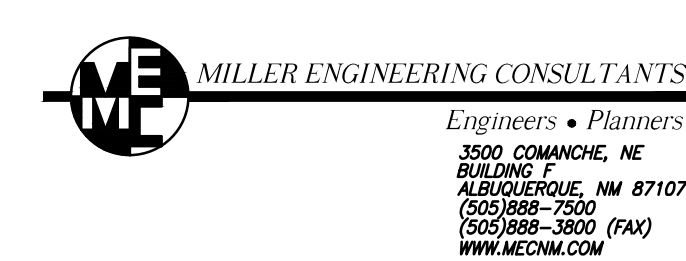
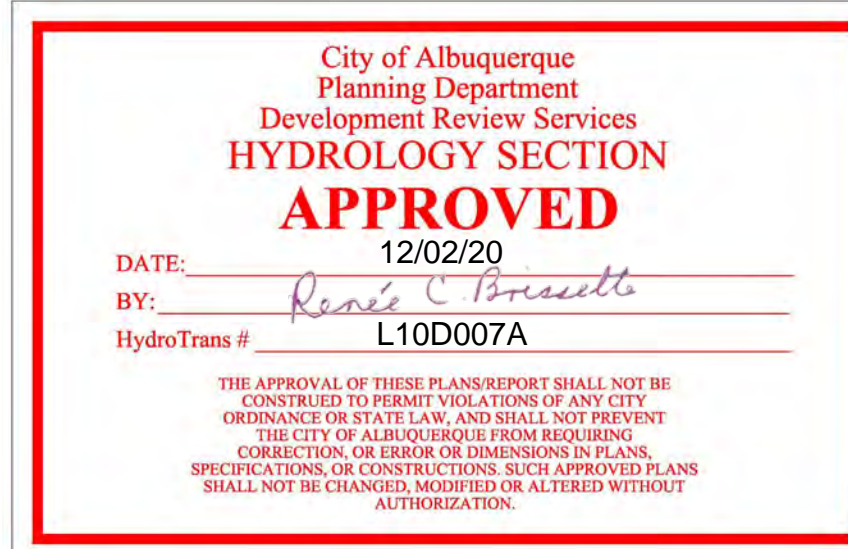

T:\Clients\BET\_ARCH\Mark Armijo Charter School\CADD\SHEDS\C-100\_HYDROLOGY\PLAN\_10-13-20.DWG, C-901\_Misc\_Details, 11/17/2020 1:36:39 PM

Mark Armijo Academy - Master Plan

CONSULTANT

ARCHITECT:  ENGINEER

**Mark Armijo Academy - Master Plan**

**Project Status**

6800 Gonzales Rd SW  
 Albuquerque, NM 87121

NOVEMBER 2020

MARK	DATE	DESCRIPTION

ISSUE:	
DATE:	
PROJECT NO:	Project Number
CAD DWG FILE:	
DRAWN BY:	Author
CHECKED BY:	Checker

SHEET TITLE

**MASS GRADING PLAN**

**C-101**

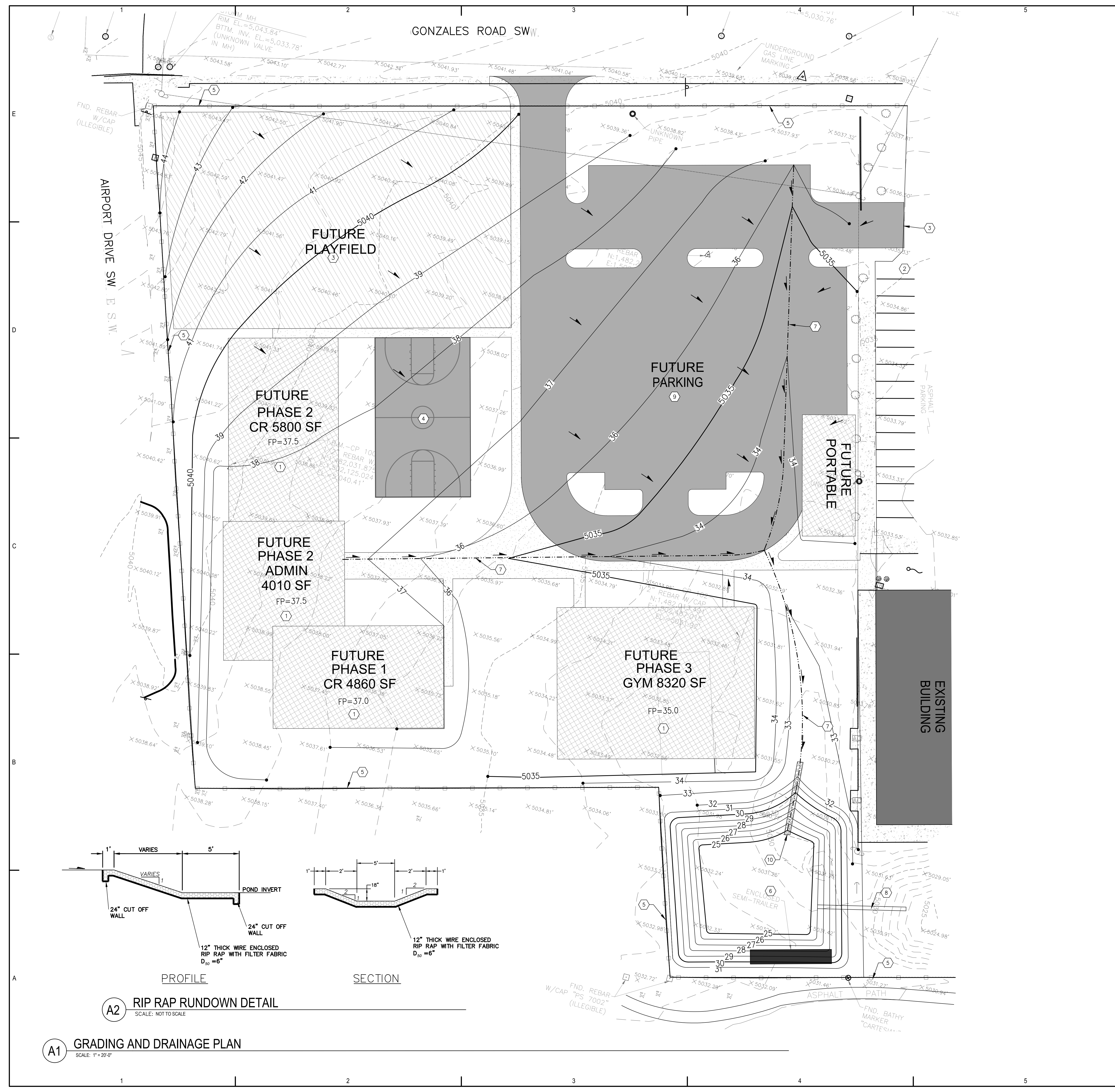

- LEGEND:**
- 38.00 PROPOSED SPOT ELEVATIONS (FINISHED GRADE)
  - MATCH (95.19) MATCH EXISTING ELEVATIONS
  - TC ON TOP OF CONCRETE
  - FL FLOW LINE, CURB
  - IN V INVERT
  - FG FINISH GRADE
  - TBC TOP OF BASE COURSE
  - TC TOP OF CURB
  - TG TOP OF GRATE
  - TA TOP OF ASPHALT
  - FLOW ARROW
  - ~ GRADE BREAK-HIGH POINT
  - SWALE
  - SD STORM DRAIN LINE
  - 5895 PROPOSED MAJOR CONTOUR
  - 5895 PROPOSED MINOR CONTOUR
  - 5895 EXISTING MAJOR CONTOUR
  - 5895 EXISTING MINOR CONTOUR

- KEYED NOTES:**
- FUTURE BUILDING SEE ARCHITECTURAL DRAWINGS.
  - EXISTING PARKING AND ASPHALT TO REMAIN.
  - FUTURE PLAY FIELD SEE LANDSCAPING PLAN.
  - FUTURE BASKETBALL COURT.
  - EXISTING PROPERTY LINE.
  - NEW RETENTION POND C. TOP=31.0, INV=25.0.
  - EARTHEN SWALE
  - NEW 24" ADS HP STORM DRAIN PIPE, L=47', S=0%, INV IN=26.0, INV OUT=26.0.
  - FUTURE PARKING LOT.
  - RIP RAP RUNDOWN, SEE DETAIL THIS SHEET.

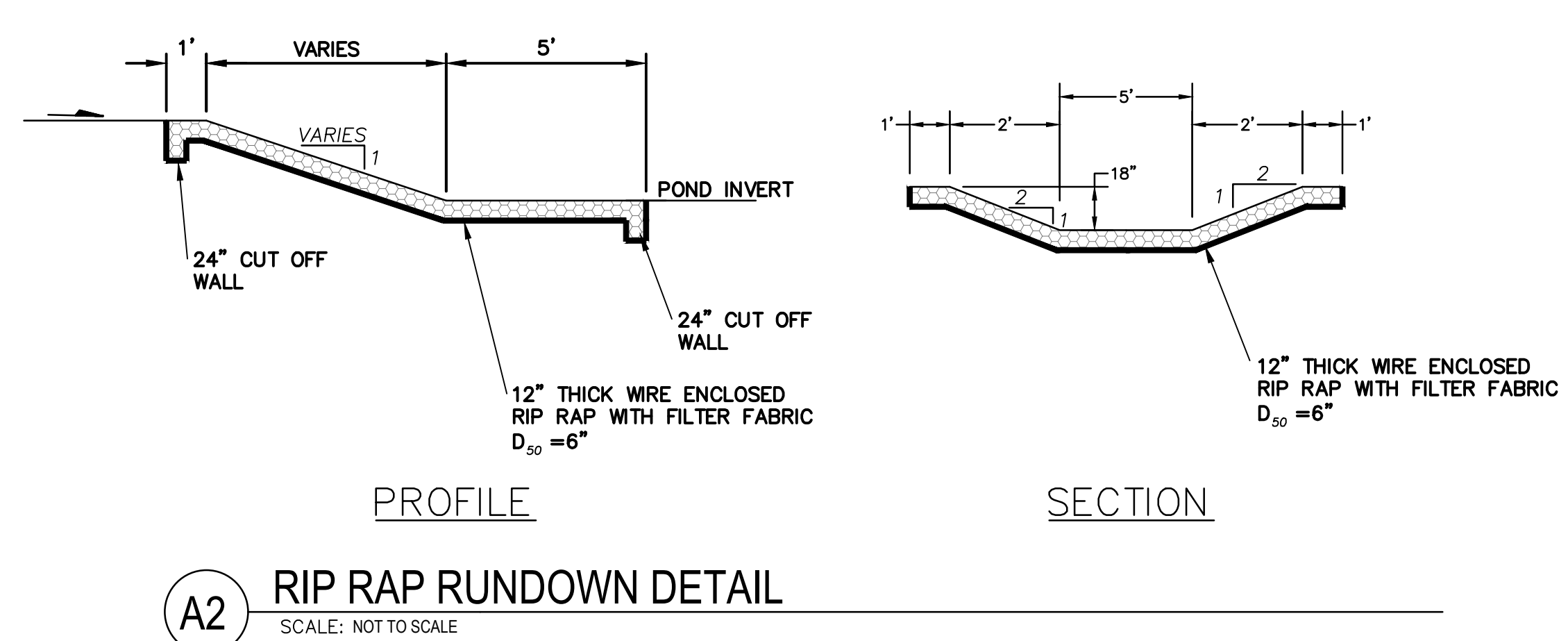
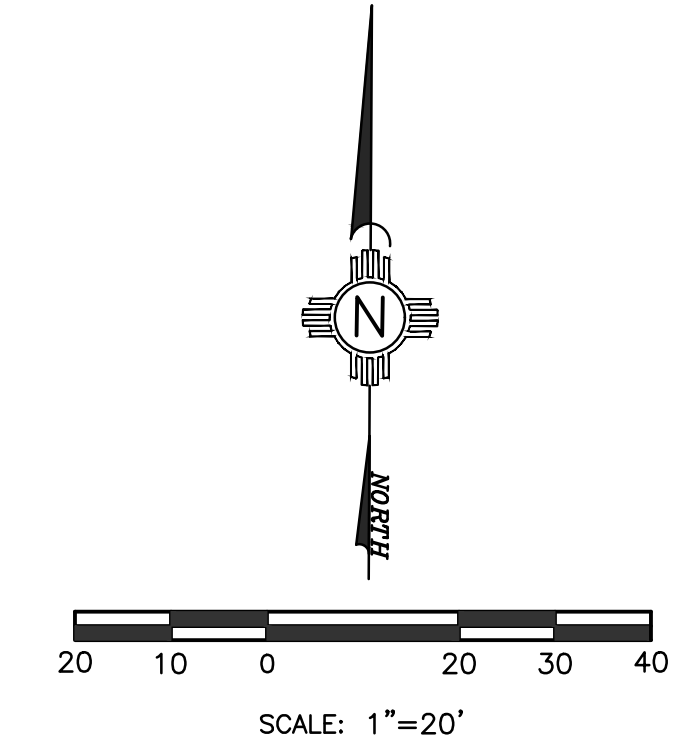

**A1 GRADING AND DRAINAGE PLAN**  
 SCALE: 1"=20'-0"

**A2 RIP RAP RUNDOWN DETAIL**  
 SCALE: NOT TO SCALE

City of Albuquerque  
 Planning Department  
 Development Review Services  
**HYDROLOGY SECTION**  
**APPROVED**

DATE: 12/02/20  
 BY: *Ronald J. Horvath*  
 HydroTrans # L10D007A

THE APPROVAL OF THESE PLANS AND PERMITS SHALL NOT BE CONSIDERED TO PRESENT WARRANTIES OF ANY CITY, COUNTY OR STATE LAW, AND SHALL NOT PREVENT THE CITY OR ALBUQUERQUE FROM RECOVERING COSTS OF INVESTIGATION OR CONSTRUCTION OF PLANS, SPECIFICATIONS OR CONTRACTS. THESE APPROVED PLANS SHALL NOT BE CHANGED, MODIFIED OR ALTERED WITHOUT NOTIFICATION.

**ME MILLER ENGINEERING CONSULTANTS**  
 Engineers • Planners  
 3500 COMBINE, NE  
 ALBUQUERQUE, NM 87107  
 (505) 883-5200 (FAX)  
 WWW.MEEN.COM

T:\Clients\BET\_ARCH\Mark Armijo Charter School\CADD\SHEETS\C-101\_Grading and Drainage Plan Earth Work Only\_9-14-2020.dwg, C-101, E, D Plan, 11/17/2020 1:35:35 PM

Mark Armijo Academy - Master Plan

GROSS FLOOR CHANGE CALCULATIONS		
GROSS BUILDING AREA	16,545 SF	
CAFETERIA	3,324 SF	
2,268 SF / 15 NET = 151 OCC.		
REQUIREMENTS (BASED ON 151 OCC)		
PARKINGS SPACES	1 SPACE FOR EA. 4 SEATS IN CAFETERIA	38
CREDITS		
10% FOR PUBLIC BUS STOP NEARBY		
38' x 1=4		34
ADA SPACES REQUIRED (FOR 26 TO 35 PARKING SPACES)		2
ADA VAN SPACES (1 FOR EA. OF 2 ADA SPACES)		1
BICYCLE SPACES (1 SPACE FOR EA. 50 STUDENTS)		4
MOTORCYCLE SPACES (FOR 26 TO 50 PARKING SPACES)		2
PROVIDED		
TOTAL SPACES		51
ADA SPACES PROVIDED		2
ADA VAN SPACES		1
BICYCLE RACK PROVIDED (CONTRACTOR TO ENSURE)		4
MOTORCYCLE SPACES PROVIDED		2

- GENERAL NOTES**
- SUB GRADE PREPERATION AND SOIL COMPACTION AT ALL CONCRETE WORK SHALL COMPLY WITH REQUIREMENTS ON CIVIL DRAWINGS AND GEOTECHNICAL REPORT.
  - PROVIDE BROOM FINISH ON CONCRETE SIDEWALKS, UNLESS NOTED OTHERWISE.
  - VERIFY SIDEWALK LAYOUT WITH ARCHITECT PRIOR TO FORMING AND POURING CONCRETE, NO EXCEPTIONS.
  - FOR INFORMATION ON UTILITIES SEE SITE SURVEY SHEET, CIVIL UTILITY PLANS, MECHANICAL, PLUMBING AND ELECTRICAL DRAWINGS.
  - CONTRACTOR SHALL PAY FOR AND COORDINATE WITH LOCAL UTILITY COMPANIES FOR ALL UTILITY DISCONNECT, RECONNECT AND DEMO WORK.
  - PATCH AND REPAIR ALL ASPHALT, CONCRETE, SOIL, OTHER SITE ELEMENTS AS NECESSARY AT ALL AREAS OF NEW WORK, UTILITY TRENCHING AND CONTRACTOR STAGING/PARKING.
  - CONTRACTOR SHALL TAKE NECESSARY PRECAUTIONS TO PROTECT EXISTING SITE FEATURES, PLANTINGS, AND UTILITIES TO REMAIN DUE TO CONSTRUCTION OPERATIONS SHALL BE REPAIRED AT NO ADDITIONAL COST TO THE OWNER.
  - WHERE NEW CONCRETE PAVEMENT AND/OR CURBING IS SHOWN ADJACENT TO EXISTING, CONTRACTOR SHALL PROVIDE NEW CONCRETE PAVEMENT AND/OR CURBING UP TO AND FLUSH WITH EXISTING LIMITS SHOWN ARE APPROXIMATE. CONTRACTOR SHALL FIELD VERIFY.
  - CONTRACTOR SHALL FIELD VERIFY ALL DIMENSIONS AND LAYOUT OF BOTH THE SITE AND BUILDING ELEMENTS COORDINATE FIELD INFORMATION WITH THE ARCHITECT PRIOR TO ANY CONSTRUCTION ACTIVITY.
  - ALL IRRIGATION SYSTEMS SHALL REMAIN ACTIVE THROUGH THE DURATION OF THE CONSTRUCTION PROJECT. CONTRACTOR SHALL BE RESPONSIBLE FOR MAINTAINING ALTERNATE IRRIGATION METHODS AS REQUIRED FOR THE CAMPUS AND FIELDS DURING ANY REQUIRED OUTAGES FOR NEW WORK.
  - CONTRACTOR TO FIELD VERIFY ANY MODIFICATIONS WILL NOT COMPROMISE IRRIGATION SYSTEM ON ANY OTHER PORTION OF THE CAMPUS.

**fbt|architects**  
 6501 Americas Pkwy NE, Ste. 300  
 Albuquerque, NM 87110  
 P\_505.883.5200 WEB: www.fbtarch.com

**CONSULTANTS**

**STRUCTURAL**  
**Walla Engineering**  
 6501 Americas Parkway, Ste 301  
 Albuquerque, NM 87110  
 p\_505.881.3008

**CIVIL**  
**Miller Engineering Consultants**  
 3500 Comanche NE, Bldg F  
 Albuquerque, NM 87107  
 p\_505.888.7500

**M/E/P/FP**  
**Bridgers and Paxton**  
 4600 C Montgomery  
 Albuquerque, NM 87109  
 p\_505.883.4111

**KEYNOTE LEGEND**

VALUE	DESCRIPTION
S01	EXISTING ASPHALT PAVING TO REMAIN. PATCH AND REPAIR AS NECESSARY TO PERFORM NEW WORK.
S02	EXISTING CHAIN-LINK FENCE TO REMAIN.
S03	EXISTING CONCRETE SIDEWALK TO REMAIN. PATCH AND REPAIR AS NECESSARY TO PERFORM NEW WORK.
S04	EXISTING OVERHEAD UTILITY LINE. SEE SURVEY. SEE ELECTRICAL.
S05	EXISTING TREES AND LANDSCAPING TO REMAIN. PROTECT. DAMAGE SHALL BE REPAIRED OR REPLACED AT NO COST TO THE OWNER.
S06	NEW CONCRETE PAVED SIDEWALK SEE DETAIL D1/AS-101
S07	NEW ADA RAMP AND LANDING BY BUILDING MANUFACTURER.

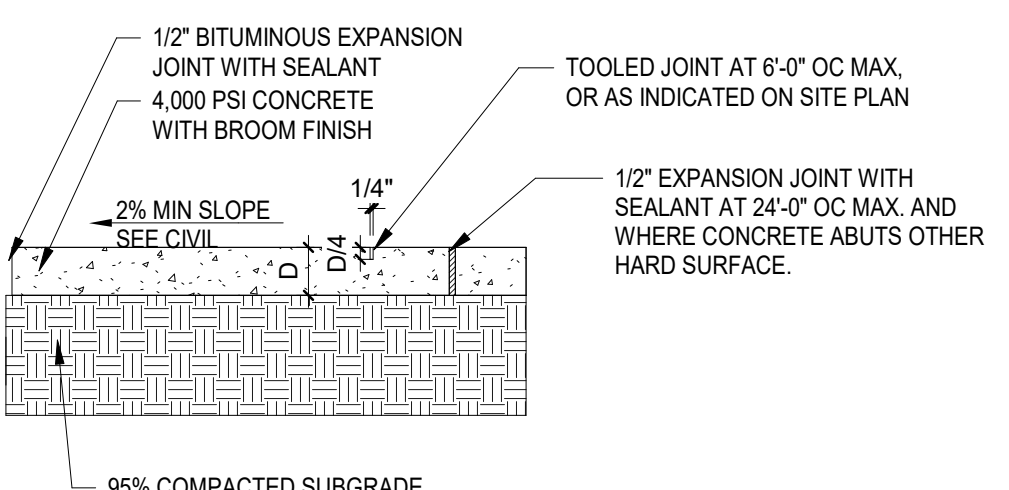

- NOTES:**
- SEE GEOTECHNICAL REPORT FOR ADDITIONAL REQUIREMENTS AND INFORMATION.
  - SEE SITE PLAN FOR CONCRETE JOINT PATTERN.
  - VERIFY SIDEWALK LAYOUT WITH ARCHITECT PRIOR TO FORMING AND POURING CONCRETE. NO EXCEPTIONS.
  - HEAVY DUTY CONCRETE SHALL BE 6" THICK WITH 6X6X10 GA. WELDED WIRE FABRIC IN CENTER OF SLAB.
  - STANDARD DUTY CONCRETE SHALL BE 4" THICK.
  - TURN DOWN EDGE AT ALL EXPOSED EDGES OF CONCRETE PAVEMENT. SEE DETAIL E1 THIS SHEET.

**D1 Concrete Pavement**  
 3/4" = 1'-0"

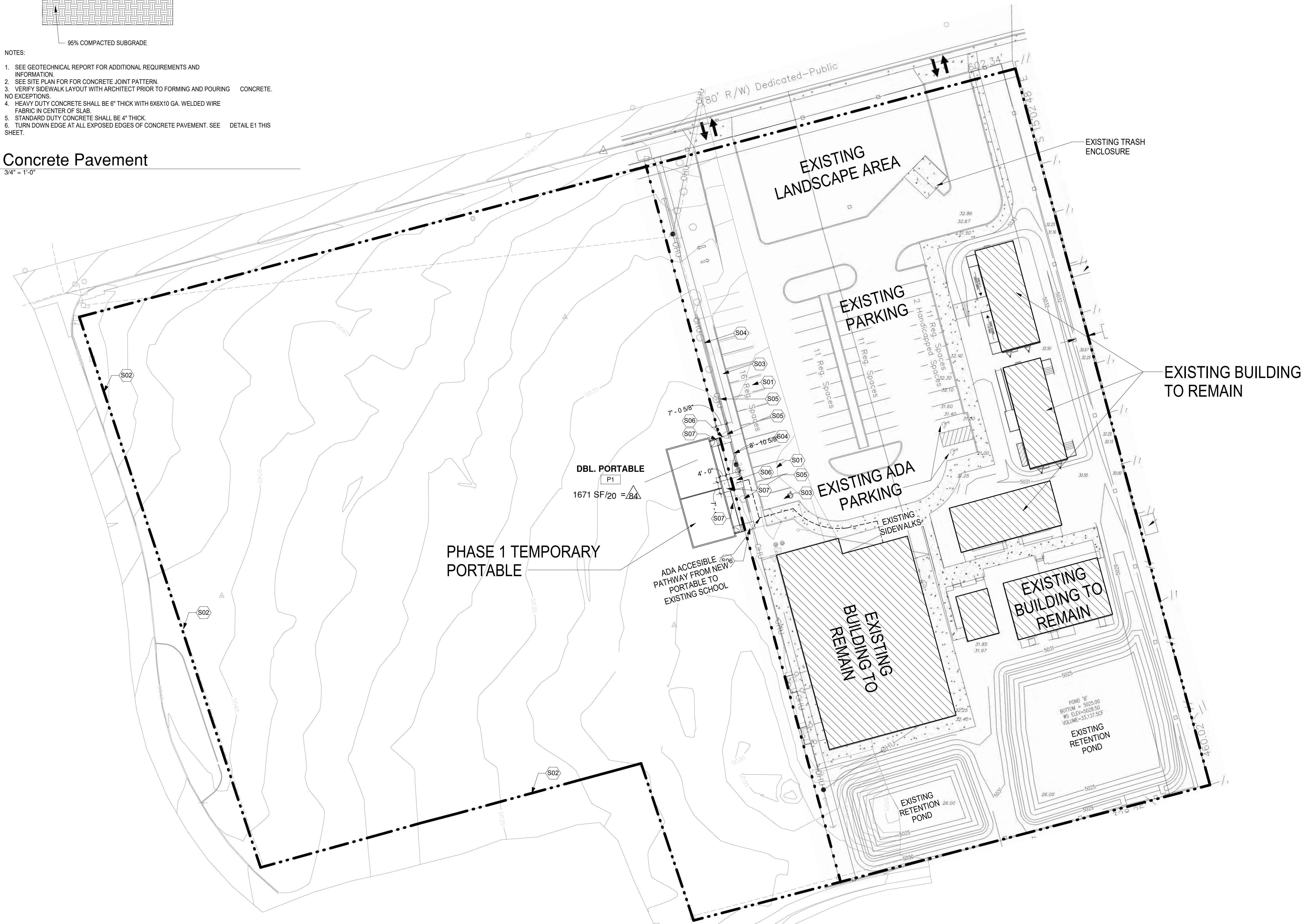

**A1 OVERALL SITE PLAN**  
 1" = 30'-0"



**Mark Armijo Academy - Site Development Plan**

**CONSTRUCTION DOCUMENTS**

6800 Gonzales Rd SW  
 Albuquerque, NM 87121

JUNE 2021

MARK	DATE	DESCRIPTION

ISSUE:	CONSTRUCTION DOCUMENTS
DATE:	JUNE 2021
PROJECT NO:	Project Number
DRAWN BY:	A.A
CHECKED BY:	JTT

SHEET TITLE  
**OVERALL SITE PLAN**

**AS-101**

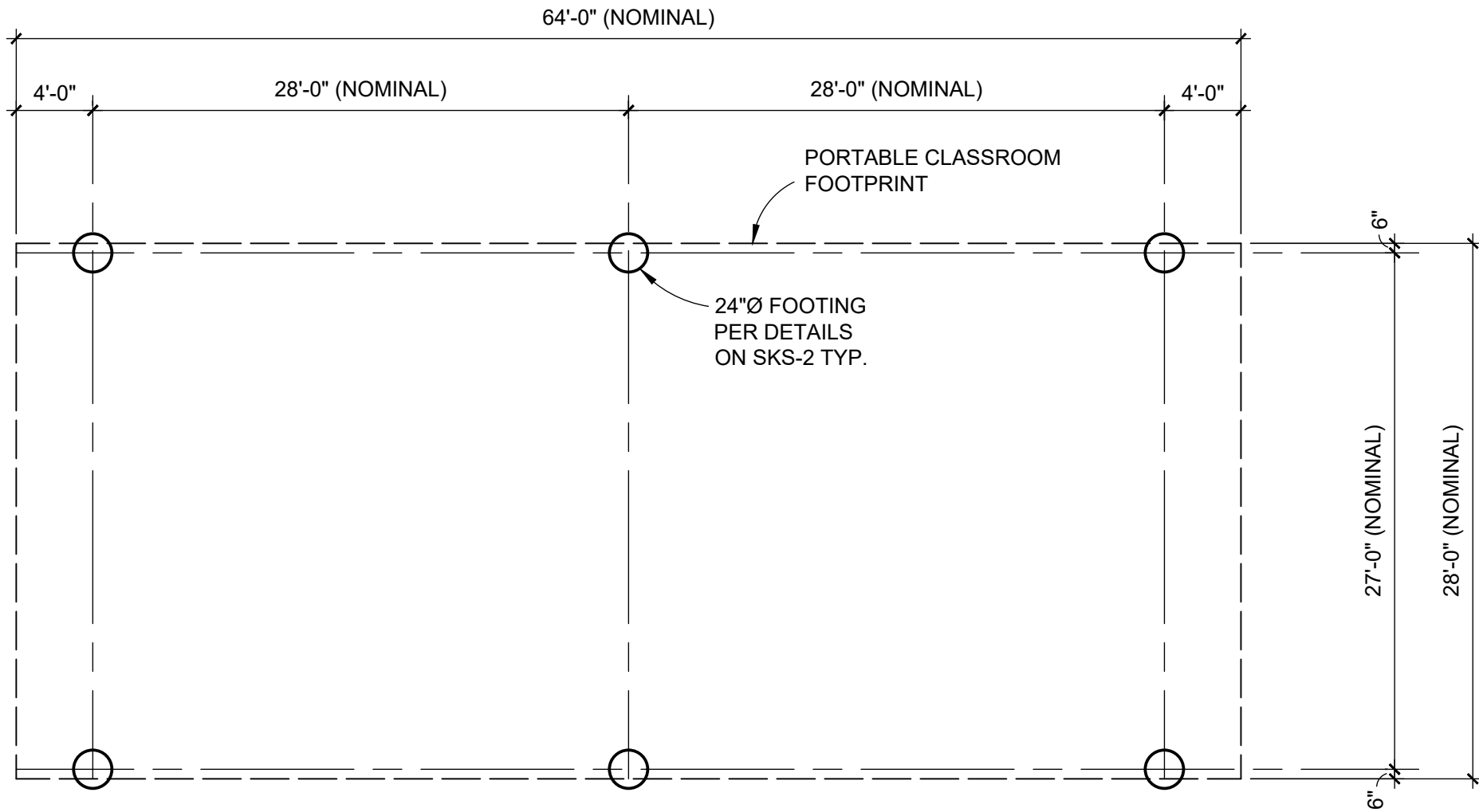

**DOUBLE PORTABLE CLASSROOM FOUNDATION PLAN**

1/8" = 1'-0"



SHEET NO. SKS-1 OF 2  
JOB MARK ARMILJO ACADEMY  
SUBJECT PORTABLE CLASSROOM FOUNDATION  
CLIENT FBI JOB NO. F01-1620  
BY LEK DATE 12-31-2020  
CHECKED BY MJW DATE 12-31-2020

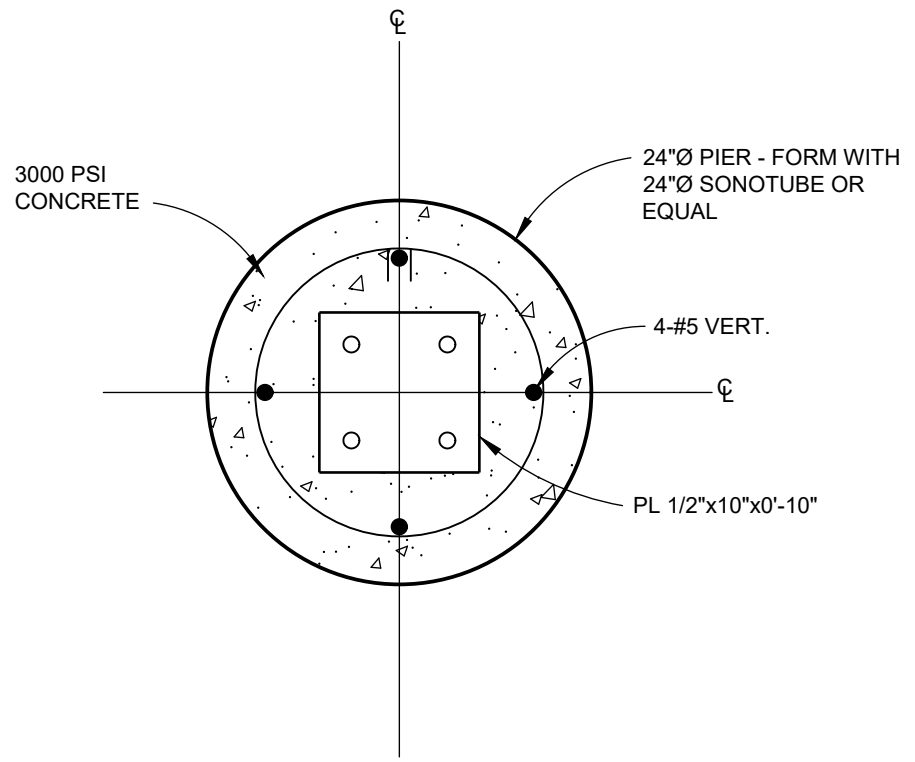

PLAN

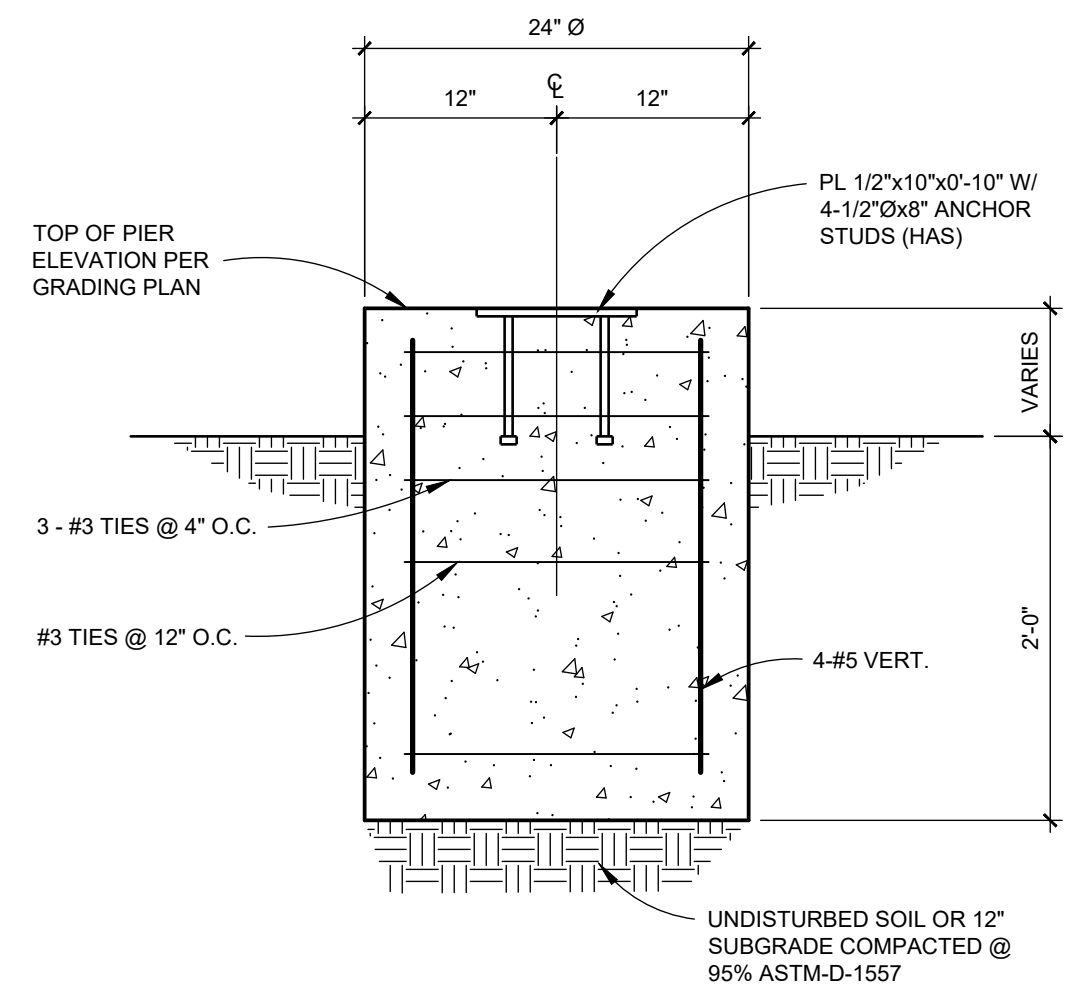

SECTION

**FOOTING DETAILS**

SCALE: 1"=1'-0"



SHEET NO.	SKS-2	OF	2
JOB	MARK ARMUJO ACADEMY		
SUBJECT	PORTABLE CLASSROOM FOUNDATION		
CLIENT	FBT	JOB NO.	F01-1620
BY	LEK	DATE	12-31-2020
CHECKED BY	MJW	DATE	12-31-2020

CONSULTANT



4600 C Montgomery Blvd. NE Albuquerque, NM 87109 | 505.883.4111 | www.bpce.com

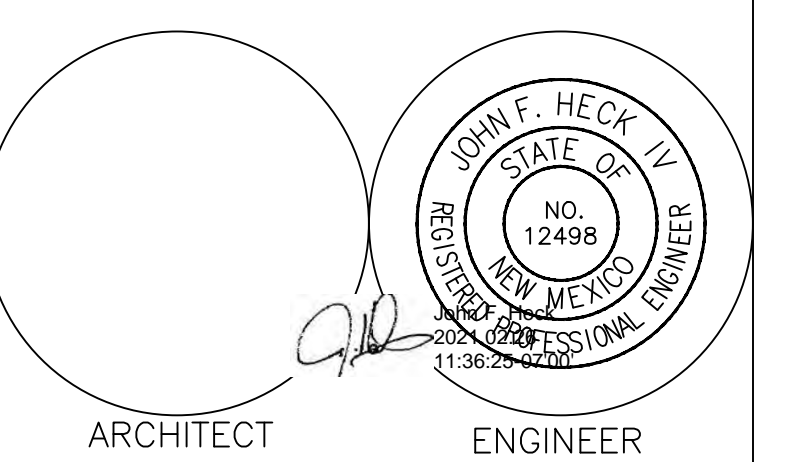

Mark Armijo Academy - Master Plan

100% CD

6800 Gonzales Rd SW Albuquerque, NM 87121

FEBRUARY 2021

MARK DATE DESCRIPTION

ISSUE: DATE: PROJECT NO: CAD DWG FILE: DRAWN BY: CHECKED BY:

SHEET TITLE ELECTRICAL LEGEND

E-001

ELECTRICAL SYMBOL LEGEND (NOT ALL SYMBOLS APPLY TO THIS PROJECT)

ABBREVIATIONS

Table of abbreviations with columns for ABBREVIATION and DEFINITION. Includes terms like AMP, AC, ADA, AFF, etc.

REFERENCE TAGS

Table of reference tags with columns for SYMBOL and DEFINITION. Includes symbols for keyed notes, mechanical equipment, etc.

EQUIPMENT NAMING CONVENTION

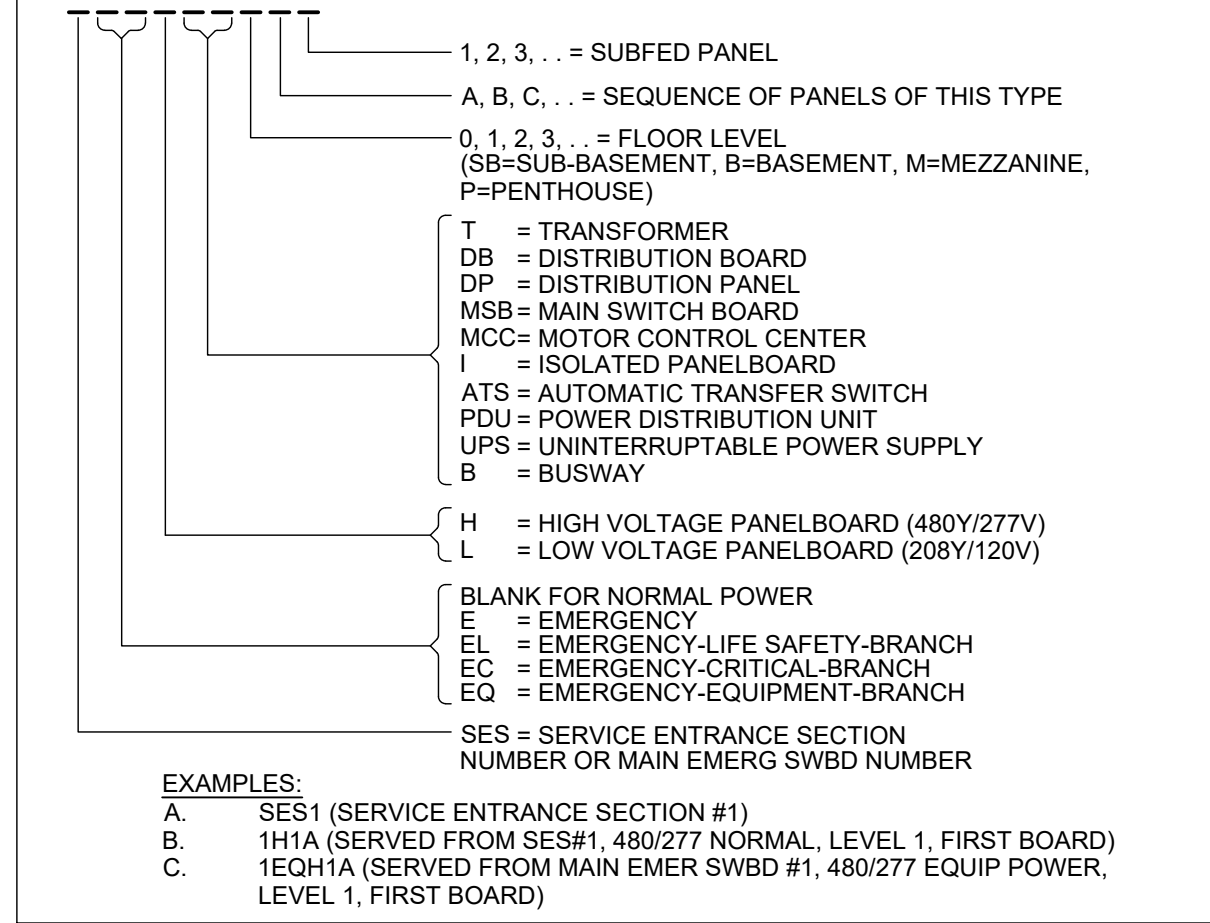

RACEWAY & CONDUCTORS

BRANCH CIRCUIT GENERAL INFORMATION: BRANCH CIRCUITS FROM OVERCURRENT PROTECTION (20A) TO FURTHEST DEVICE SHALL NOT EXCEED 75 FEET FOR #12AWG COPPER AND 150 FEET FOR #10AWG COPPER...

Table for raceway and conductors with columns for SYMBOL, DESCRIPTION, and diagrams for various symbols like LA-1, LA-1.3, etc.

GENERAL DRAWING SYMBOLS

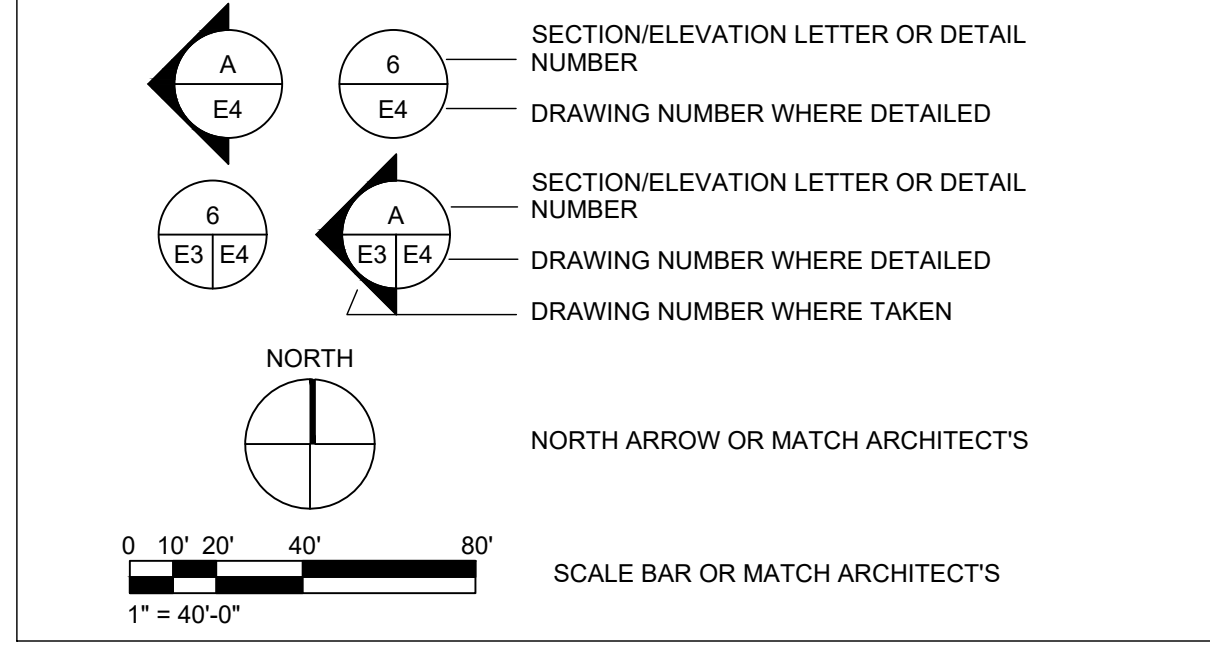

DEMOLITION

Table for demolition symbols with columns for SYMBOL, DESCRIPTION, and NOTES. Includes symbols for existing equipment to be removed, etc.

DEVICES

DEVICE INDICATOR LETTER "X" EQUALS DESIGNATION BELOW (TYPICAL FOR MOST RECEPTACLE TYPES): BLANK FOR NORMAL POWER, G = GFCI RATED, IG = ISOLATED GROUND, etc.

Table of electrical devices with columns for SYMBOL, DESCRIPTION, and MOUNTING. Includes duplex receptacles, switches, outlets, etc.

EQUIPMENT

Table of electrical equipment with columns for SYMBOL and DESCRIPTION. Includes main switchboards, distribution boards, transformers, etc.

LIGHTING

REFER TO LUMINAIRE SCHEDULE FOR ALL LUMINAIRE TYPES WHETHER WALL MOUNTED OR CEILING MOUNTED.

Table of lighting symbols with columns for SYMBOL, DESCRIPTION, and MOUNTING. Includes recessed, surface, and wall-mounted luminaires.

UTILITIES

Table of utility symbols with columns for SYMBOL and DESCRIPTION. Includes distribution poles, transformers, and ground connections.

FIRE ALARM

REFER TO LIGHTING SCHEDULE

Table of fire alarm symbols with columns for SYMBOL, DESCRIPTION, and MOUNTING. Includes fire alarm control panels, horns, and detectors.

ONE-LINE DIAGRAM

Table of one-line diagram symbols with columns for SYMBOL, DESCRIPTION, and diagrams. Includes circuit breakers, transformers, and disconnects.

Date: Feb 25, 2021 - 10:31am User: A.Gonzales ... Drawing File: H:\BQ\819\CAD\AutoCAD\0319 - AFS - Mark Armijo Academy Charter School Portable Re-location\Sheets\Electrical\819-ES101.dwg ... Last Saved By: A.Gonzales Feb 25, 2021 - 8:28am ... Layout Name: ES101

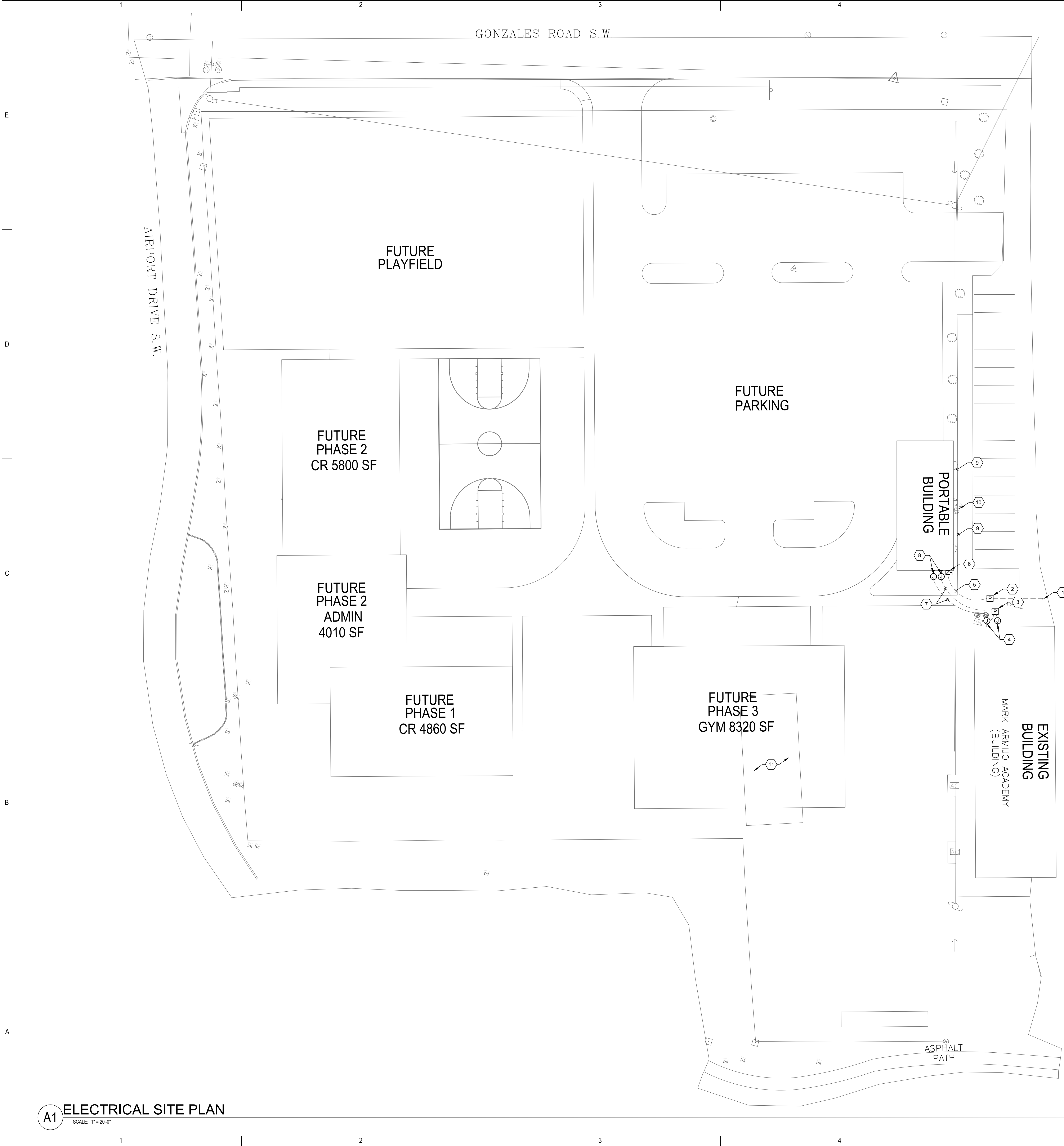

**GENERAL NOTES:**

1. SHOULD CONTRACTOR AT ANY TIME NOTICE THAT THE ACTUAL FIELD CONDITIONS DO NOT CORRESPOND TO THE INFORMATION GIVEN ON THE DRAWINGS, THEN IT WILL BE THEIR RESPONSIBILITY TO NOTIFY THE ENGINEER FOR CLARIFICATION, PRIOR TO COMMENCING SUCH WORK.
2. IT SHALL BE THE RESPONSIBILITY OF THE CONTRACTOR TO COORDINATE WITH ALL TRADES FOR THE EXACT LOCATION OF EQUIPMENT THAT REQUIRE ELECTRICAL CONNECTIONS.
3. CONTRACTOR WILL REFER TO SHEET SERIES "C" FOR OTHER NEW AND EXISTING UTILITIES. MUST COORDINATE INSTALLATION OF ALL UTILITIES SHOWN ON THIS SHEET PRIOR TO COMMENCEMENT OF ANY WORK.

**KEYED NOTES:**

1. EXISTING UNDERGROUND 2" CONDUIT FROM UNDER PARKING AREA CONDUIT ENDS ARE BURIED AND EXTEND UNDER LENGTH OF PARKING AREA FROM EAST TO WEST. COORDINATE EXACT LOCATION OF CONDUIT ENDS WITH SCHOOL REPRESENTATIVE. PROVIDE AN IN-GROUND PULL BOX AT EACH END OF CONDUIT. ON EAST END EXTEND UNDERGROUND CONDUIT FROM PULL BOX TO MAIN DISTRIBUTION PANEL. REFER TO SHEET E601 FOR ADDITIONAL INFORMATION.
2. PROVIDE NEW CODE SIZED, PRECAST CONCRETE IN-GROUND PULL BOX FOR EXTENSION OF EXISTING UNDERGROUND 2" CONDUIT TO NEW PORTABLE.
3. PROVIDE NEW CODE SIZED, PRECAST CONCRETE IN-GROUND PULL BOX FOR EXTENSION OF DATA AND FIRE ALARM CONNECTION FROM MAIN BUILDING VIA EXISTING WALL MOUNTED JUNCTION BOXES LOCATED ON MAIN BUILDING.
4. EXISTING BUILDING MOUNTED JUNCTION BOXES FOR DATA AND FIRE ALARM CONNECTION FROM MAIN BUILDING. EXTEND CONDUIT AND WIRE FROM RESPECTIVE SOURCES IN MAIN BUILDING, ABOVE LAY-IN TILE CEILING SPACE, TO JUNCTION BOXES INDICATED AND DOWN TO IN-GROUND PULL BOX.
5. PROVIDE UNDERGROUND 2" CONDUIT EXTENSION FROM IN-GROUND PULL BOX TO NEW PORTABLE ALONG WITH (3) #1 COPPER CONDUCTORS AND A #6 GND AS A SINGLE CONTINUOUS RUN FROM MAIN DISTRIBUTION PANEL.
6. REMOVE EXISTING DISCONNECT SWITCH AND REPLACE WITH NEW. REFER TO SHEET E601 FOR ADDITIONAL INFORMATION.
7. PROVIDE UNDERGROUND 1" CONDUIT AND CONDUCTORS FOR DATA AND FIRE ALARM CONNECTION TO PORTABLE FROM EXISTING CONNECTIONS IN MAIN BUILDING VIA IN-GROUND PULL BOX.
8. PROVIDE NEW WEATHERPROOF, WALL MOUNTED JUNCTION BOXES FOR DATA AND FIRE ALARM CONNECTION TO PORTABLE.
9. OVERHEAD PNM POWER LINES. MAINTAIN A MINIMUM OF 5'-0" FROM EDGE OF PORTABLE ROOF TO OVERHEAD LINES.
10. EXISTING PNM POWER POLE. MAINTAIN A MINIMUM OF 10'-0" FROM POWER POLE FOR PNM ACCESS.
11. EXISTING LOCATION OF PORTABLE. DOES NOT PRESENTLY HAVE ANY UTILITY SERVICES.

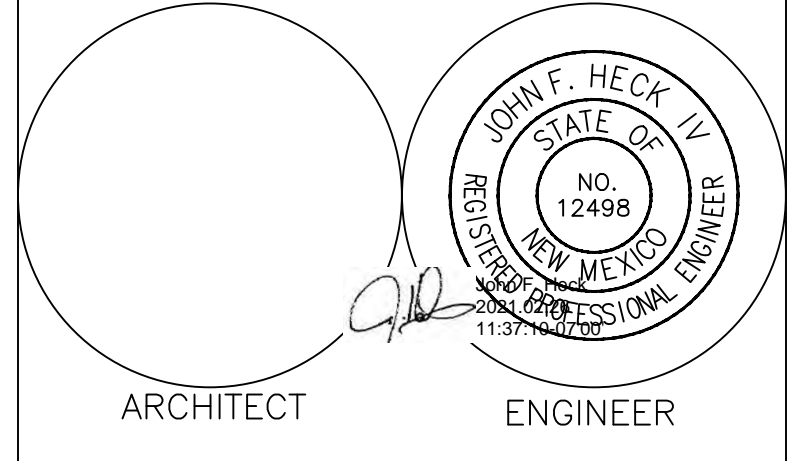

**Mark Armijo Academy - Master Plan**

**100% CD**

6800 Gonzales Rd SW  
Albuquerque, NM 87121

FEBRUARY 2021

MARK	DATE	DESCRIPTION

ISSUE:	
DATE:	
PROJECT NO:	Project Number
CAD DWG FILE:	
DRAWN BY:	
CHECKED BY:	

SHEET TITLE  
**ELECTRICAL SITE PLAN**

**ES101**

**A1 ELECTRICAL SITE PLAN**  
SCALE: 1"=20'0"

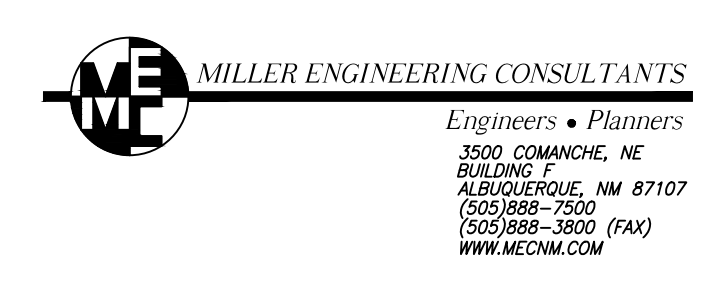
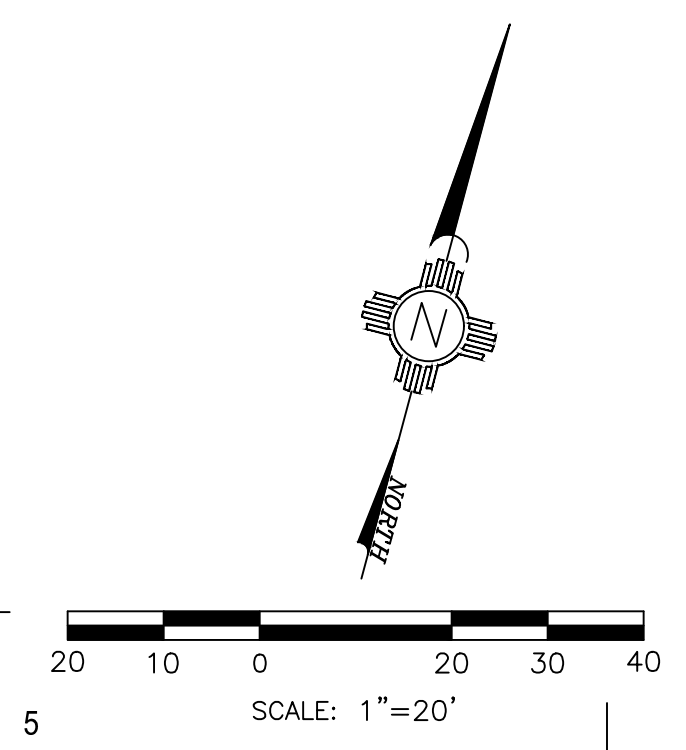

Mark Armijo Academy - Master Plan



Date: Feb 25, 2021 - 10:31am User: AJGonzales ... Drawing File: H:\B0819\CAD\AutoCAD\AutoCAD0819 - AFS - Mark Armijo Academy Charter School Portable Re-location\Sheets\Electrical\B19-E-601.dwg ... Last Saved By: AJGonzales Feb 25, 2021 - 10:29am ... Layout Name: E-601

GENERAL NOTES:

- SHOULD CONTRACTOR AT ANY TIME NOTICE THAT THE ACTUAL FIELD CONDITIONS DO NOT CORRESPOND TO THE INFORMATION GIVEN ON THE DRAWINGS, THEN IT WILL BE THEIR RESPONSIBILITY TO NOTIFY THE ENGINEER FOR CLARIFICATION, PRIOR TO COMMENCING SUCH WORK.
- IT SHALL BE THE RESPONSIBILITY OF THE CONTRACTOR TO COORDINATE WITH ALL TRADES FOR THE EXACT LOCATION OF EQUIPMENT THAT REQUIRE ELECTRICAL CONNECTIONS.

KEYED NOTES:

- EXISTING EQUIPMENT WILL REMAIN AS PRESENTLY INSTALLED.
- PROVIDE NEW 2 POLE, 240V CIRCUIT BREAKER, SIZE AS INDICATED, CIRCUIT BREAKER TO MATCH PANEL AIC RATING AND FAMILY OF CIRCUIT BREAKERS PRESENTLY INSTALLED.
- EXISTING UNDERGROUND 2" CONDUIT UNDER PARKING AREA, INTERCEPT AND EXTEND TO NEW IN-GROUND PULL BOX.
- PROVIDE UNDERGROUND 2" CONDUIT EXTENSION FROM PULL BOX TO EXISTING MAIN DISTRIBUTION PANEL.
- PROVIDE UNDERGROUND 2" CONDUIT EXTENSION FROM PULL BOX TO NEW PORTABLE DISCONNECT SWITCH.
- PROVIDE CONDUCTORS, SIZE AS INDICATED, AS A SINGLE CONTINUOUS RUN FROM PORTABLE DISCONNECT SWITCH, THROUGH IN-GROUND PULL BOXES, TO EXISTING MAIN DISTRIBUTION PANEL.
- PORTABLE MOUNTED DISCONNECT SWITCH, PROVIDE 250V RATED, 100A, NEMA 3R, KNIFE BLADE, FUSED DISCONNECT. RECONNECT EXISTING CONDUCTORS PRESENTLY INSTALLED FROM EXISTING PANEL IN PORTABLE TO SECONDARY SIDE OF DISCONNECT.
- PROVIDE A GROUND ROD ELECTRODE SYSTEM PER NEC 250. DO NOT BOND GROUND AND NEUTRAL CONDUCTORS.

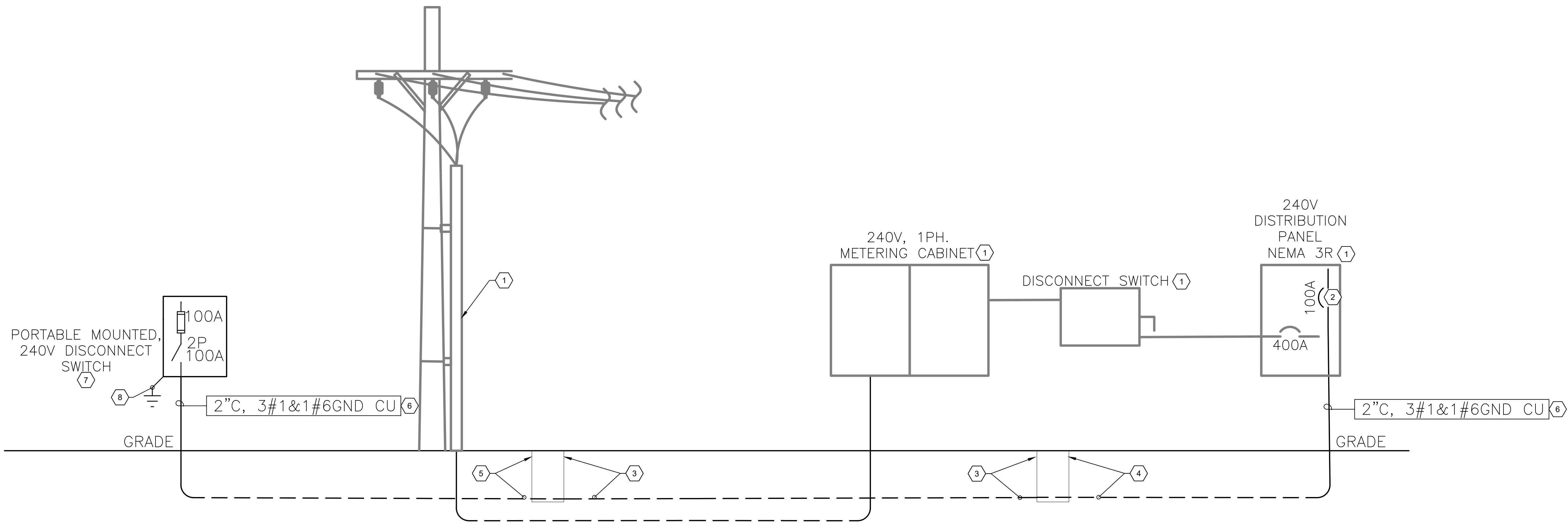

**C1 ELECTRICAL DIAGRAMS**  
 SCALE: 1" = 20'-0"

Elec. Service Calc. - M.A Academy Portable Load						
Description of Load	Sq. Ft.	Connected Load KVA	Demand % Multiplier	Demand Load KVA	Service % Multiplier	Service Load KVA
Portable	1,200	12	100%	12	100%	15
<b>Subtotal of loads KVA</b>		<b>12</b>		<b>12</b>		<b>15</b>
		<b>Total Service load KVA</b>				<b>15</b>
		<b>Voltage of Service (240-1PH)</b>				<b>0.240</b>
		<b>Total Service Ampacity</b>				<b>63</b>
<b>1,200 Sq. Ft.</b>		<b>10.00 watts/sq.ft. Portable =</b>				<b>12,000 VA</b>
<b>NOTES</b>						

**A1 PORTABLE SERVICE CALCULATION**

Maximum voltage drop for a Branch Circuit shall be less than 3% (NEC 210.19 A, FPN 4).  
 Maximum voltage drop for a Feeder shall be less than 3% (NEC 215.2, FPN 2).  
 Maximum combined voltage drop for a Feeder and Breaker shall be less than 5%.  
 Source: 2017 NEC

Run	Feeder or Branch Circuit Run:	Type of Circuit	Voltage	Phase	Conductor Material	Length (ft)	Size	Load Current (Amps)	Qty Parallel Runs	Load on Feeder	Resistance	Voltage Drop	% Voltage Drop Feeder	% Voltage Drop Branch
1	MDP TO PORTABLE DISCONNECT	Feeder	240	1	C	150	1	100	1	100	0.154	4.62	1.93%	

**B3 VOLTAGE DROP CALCULATION**

KNOWN FAULT INFORMATION				SECOND TRANSFORMER IN SYSTEM (DRY-TYPE)				FEEDER BRANCH CIRCUIT CALCULATION						RESULT					
Fault Point	Equipment	Source of Fault	Available Fault Current	XFMR Size (kVA)	Secondary Voltage:	Xmtr Impedance (Ohms):	Xmtr Impedance (user input):	"f" factor	"M" factor	Conductor Type	Conductor Size	3 single conductors?	Conduit Type	Number of sets	Length to fault	"C" value	"f" factor	"M" factor	Available Short Circuit Current at Fault:
F1	MDP	PNM POLE	65000	240	1					C	600	Y	S	1	150	22965	3.538	0.220	<b>14324</b>
F2	PORTABLE DISCONNECT	MDP	14324	240	1					C	1	Y	S	1	150	7293	2.455	0.289	<b>4146</b>

**A3 FAULT CURRENT CALCULATION**

**Mark Armijo Academy - Master Plan**

**100% CD**

6800 Gonzales Rd SW  
 Albuquerque, NM 87121

FEBRUARY 2021

MARK	DATE	DESCRIPTION

ISSUE:  
 DATE:  
 PROJECT NO: Project Number  
 CAD DWG FILE:  
 DRAWN BY:  
 CHECKED BY:

SHEET TITLE  
**ELECTRICAL DIAGRAMS**

**E-601**

# CITY OF ALBUQUERQUE

Planning Department  
Brennon Williams, Director



Mayor Timothy M. Keller

February 3, 2021

Verlyn Miller, P.E.  
Miller Engineering Consultants, Inc  
3500 Comanche NE Bldg. F  
Albuquerque, NM 87107

**RE: Mark Armijo Charter School  
6800 Gonzales Road SW  
Grading and Drainage Plan  
Engineer's Stamp Date: 01/13/21  
Hydrology File: L10D007A**

Dear Mr. Miller:

PO Box 1293

Based upon the information provided in your submittal received 01/14/2021, the Grading & Drainage Plan is approved for Building Permit and Grading Permit.

Albuquerque

Please attach a copy of this approved plan in the construction sets for Building Permit processing along with a copy of this letter. Prior to approval in support of Permanent Release of Occupancy by Hydrology, Engineer Certification per the DPM checklist will be required.

NM 87103

If the project total area of disturbance (including the staging area and any work within the adjacent Right-of-Way) is 1 acre or more, then an Erosion and Sediment Control (ESC) Plan and Owner's certified Notice of Intent (NOI) is required to be submitted to the Stormwater Quality Engineer (Doug Hughes, PE, [jhughes@cabq.gov](mailto:jhughes@cabq.gov), 924-3420) 14 days prior to any earth disturbance.

[www.cabq.gov](http://www.cabq.gov)

Also as a reminder, please provide the Drainage Covenant for the proposed retention pond per Article 6-15(C) of the DPM as soon as possible. There is a recording fee (\$25, payable to Bernalillo County). Please contact Charlotte LaBadie ([clabadie@cabq.gov](mailto:clabadie@cabq.gov), 924-3996). Due to COVID-19, please follow the instructions:

Either email a pdf copy of the executed drainage covenant and the exhibit to [clabadie@cabq.gov](mailto:clabadie@cabq.gov) or either mail or drop off the originals. Please mail the \$25.00 recording fee check made payable to Bernalillo County to:

Planning Dept./DRC  
Attn: Charlotte LaBadie  
600 2nd St. NW, Ste. 400  
ABQ, NM, 87102

# CITY OF ALBUQUERQUE

*Planning Department*  
Brennon Williams, Director



*Mayor Timothy M. Keller*

If you drop off the originals, there is a drop box outside the building labeled DRC. Once approved and recorded, Charlotte will email you a copy.

If you have any questions, please contact me at 924-3995 or [rbrissette@cabq.gov](mailto:rbrissette@cabq.gov).

Sincerely,

*Renée C. Brissette*

Renée C. Brissette, P.E. CFM  
Senior Engineer, Hydrology  
Planning Department

PO Box 1293

Albuquerque

NM 87103

[www.cabq.gov](http://www.cabq.gov)

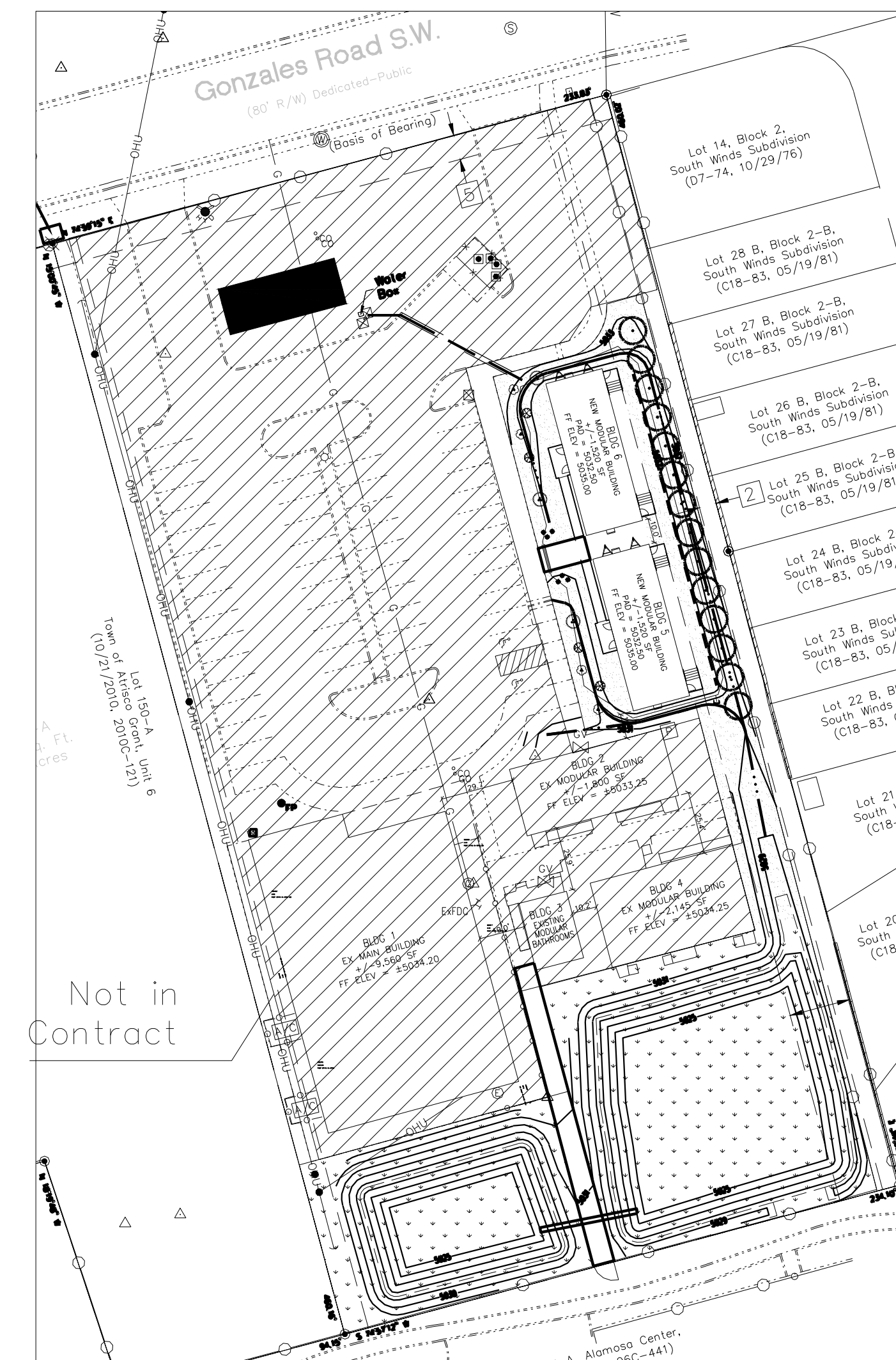

## Area Map

scale: 1"=50'-0"

## LANDSCAPE DATA

GROSS LOT AREA	33,424 SF
LESS BUILDING(S)	3,040 SF
NET LOT AREA	30,384 SF
REQUIRED LANDSCAPE 15% OF NET LOT AREA	4,558 SF
PROVIDED LANDSCAPE AREA	28,195 SF
PERCENT OF NET LOT AREA	92 %
HIGH WATER USE TURF NONE PROPOSED	
REQUIRED STREET TREES	0
PROVIDED AT 30' O.C. SPACING STREET	0
PROVIDED SPECIAL BUFFER SCREENING TREES	14
REQUIRED PARKING LOT TREES	0
PROVIDED AT 1 PER 10 SPACES (00 SPACES/10)	0
REQUIRED LANDSCAPE COVERAGE 75% LIVE VEGETATIVE MATERIAL (28,195 SF x 75%)	21,146 SF MIN.
PROVIDED LANDSCAPE COVERAGE	760 SF (75%)
PROVIDED NATIVE SEED COVERAGE	20,388 SF (100%)

## PLANT SCHEDULE

EVERGREEN TREES	QTY	BOTANICAL NAME / COMMON NAME	SIZE	WATER	COVERAGE
	14	Juniperus virginiana / Eastern Red Cedar	6'-8" B&B	Low +	30 = 420
DECIDUOUS SHRUBS	QTY	BOTANICAL NAME / COMMON NAME	SIZE	WATER	COVERAGE
	4	Perovskia atriplicifolia / Russian Sage	5 gal	Medium	20 = 80
DESERT ACCENTS	QTY	BOTANICAL NAME / COMMON NAME	SIZE	WATER	COVERAGE
	4	Hesperaloe parviflora / Red Yucca	5 gal	Low+	20 = 80
	3	Yucca thompsoniana / Thompson's Yucca	24" box	RW	40 = 120
FLOWERING PLANTS	QTY	BOTANICAL NAME / COMMON NAME	SIZE	WATER	COVERAGE
	6	Achillea x 'Moonshine' / Moonshine Yarrow	1 gal	Medium	10 = 60

LANDSCAPE COVERAGE: 760 SF

## REFERENCE NOTES SCHEDULE

SYMBOL	DESCRIPTION	QTY	DETAIL
	Mountainair Brown 7/8" Gravel	7,806 sf	
	Native Seeding	20,387 sf	

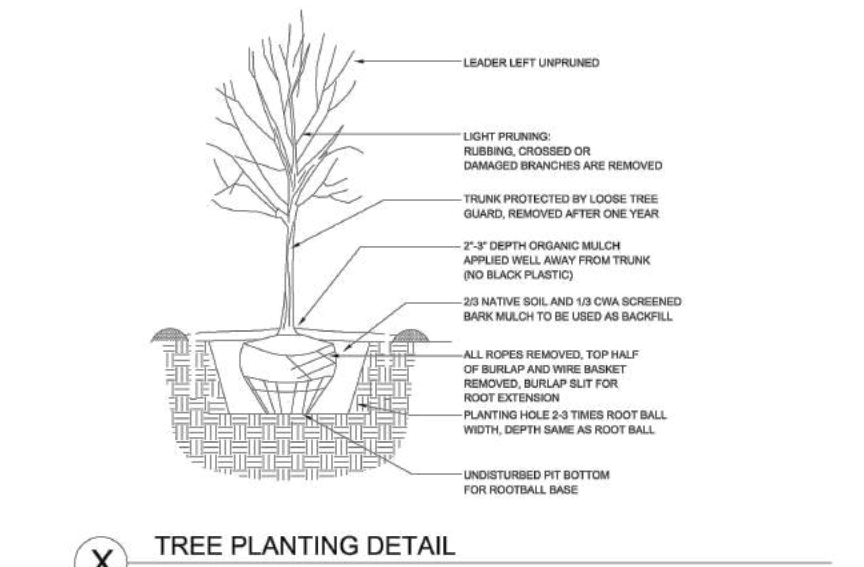
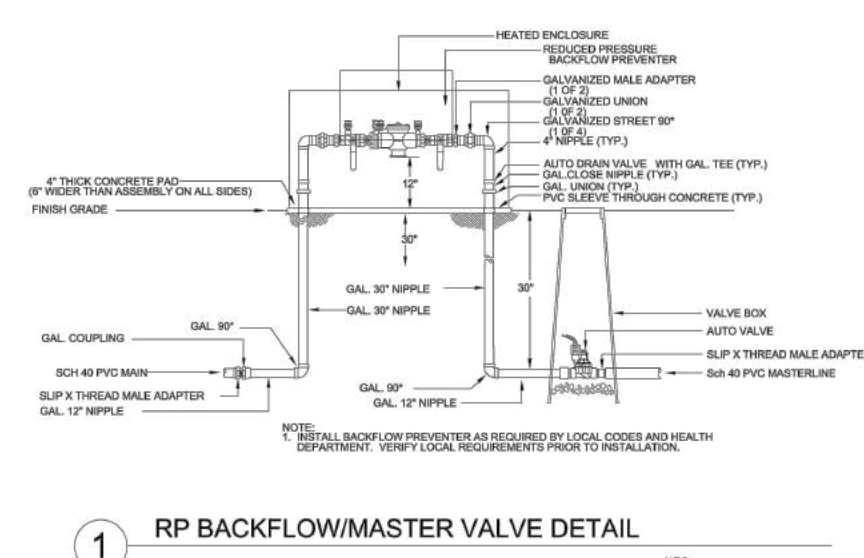

## NOTE

MAINTENANCE OF LANDSCAPE (ONSITE AND WITHIN ROW) TO BE MAINTAINED BY PROPERTY OWNER

PLANTINGS TO BE WATERED BY AUTO. DRIP IRRIGATION SYSTEM WITH REDUCED PRESSURE BACKFLOW PREVENTER PER CITY OF ALBUQUERQUE

LANDSCAPE AREAS TO BE MULCHED WITH GRAVEL MULCH AT 3" DEPTH MINIMUM OVER FILTER FABRIC

## IRRIGATION NOTE

DRIP SYSTEM RUN CYCLES:  
ESTABLISHMENT AND SUMMER:  
1 HOUR/4 DAYS A WEEK

SPRING:  
1 HOUR/2-3 DAYS A WEEK

FALL:  
1 HOUR/2-3 DAYS A WEEK

WINTER:  
1 HOUR/2 DAYS PER MONTH

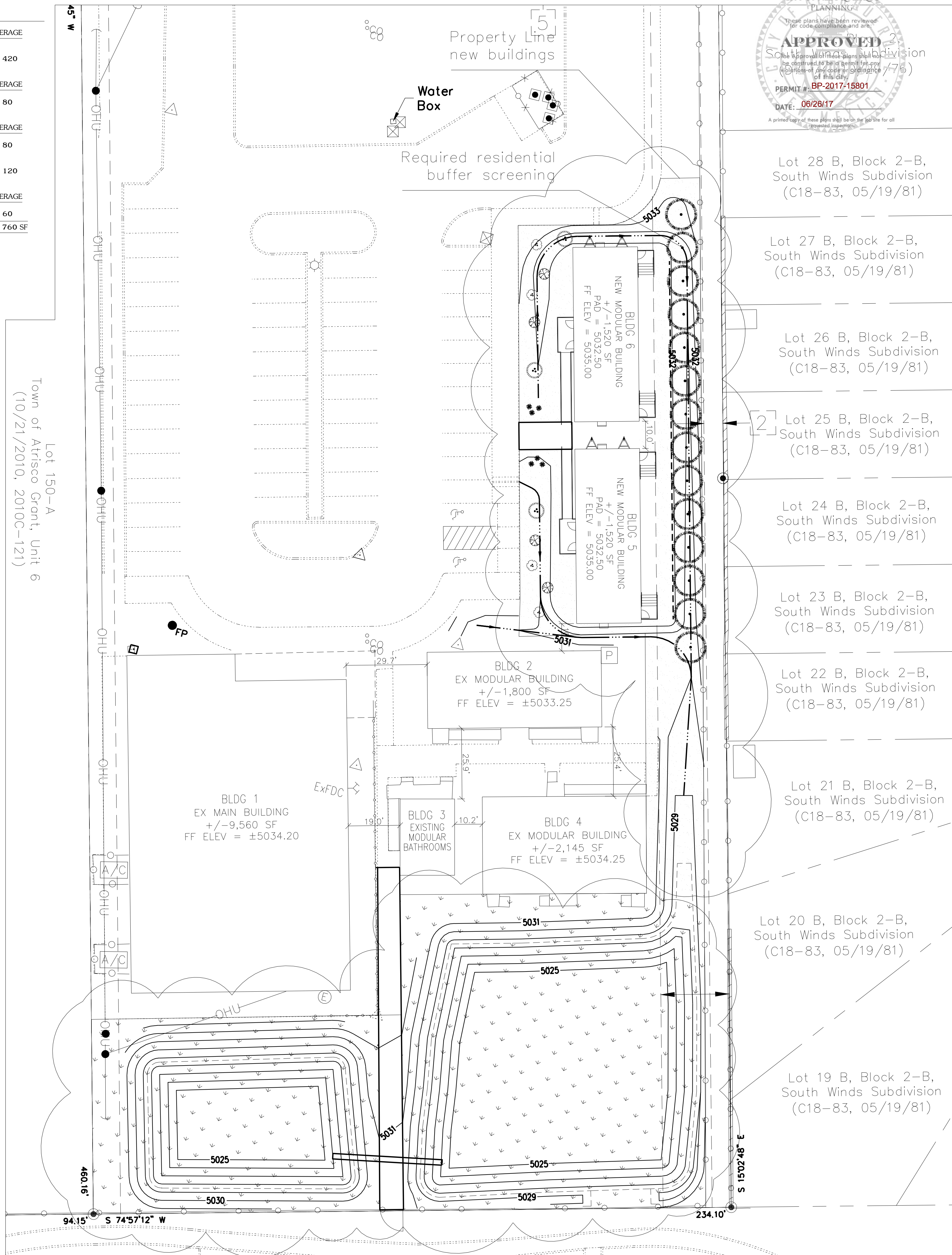

growing better  
**Up Heads**  
LANDSCAPE CONTRACTORS  
www.headsuplandscape.com

P.O. Box 10597  
Albuquerque, NM 87184  
505.898.9615  
505.898.2105 (fax)  
design@hulc.com

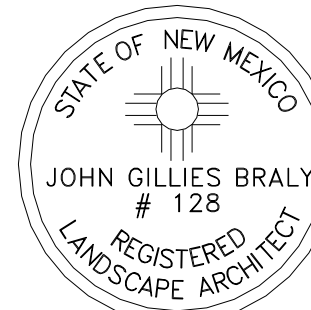

Date: 4/17/2017

Revisions:

- ▲ 4/28/2017
- ▲ 6/13/2017
- ▲
- ▲

Drawn by: E.C.G.  
Reviewed by: Hulc

**Nuestros Valores**  
Charter High School  
6800 Gonzales Rd  
Albuquerque, New Mexico

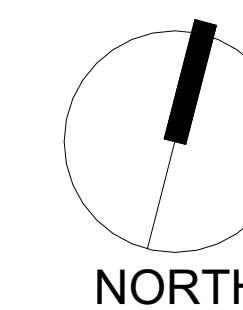

Scale: 1" = 20'



Sheet Title:  
**Landscape Plan**

Sheet Number:

**LS-01**

S:\DESIGN1 - ACTIVE JOBS\Nuestros Valores - 6800 Gonzales Rd\HULC-CAD\2017\06.12.NVCHS\_LSD.dwg 6/13/2017 2:05:23 PM, DWG To PDF.pc3

# CITY OF ALBUQUERQUE



Planning Department  
Brennon Williams, Director

Mayor Timothy M. Keller

August 31, 2021

Jeremy Trumble, RA  
FBT Architects  
6501 Americas PKWY NE, Ste 300  
Albuquerque, NM 87110

**Re: Mark Armijo-Portable Addition  
6800 Gonzales Rd SW  
Traffic Circulation Layout  
Architect's Stamp 08-09-2021 (L10-D007A)**

Dear Mr. Trumble,

The TCL submittal received 08-30-2021 is approved for Building Permit with. A copy of the stamped and signed plan will be needed for each of the building permit plans. Please keep the original to be used for certification of the site for final C.O. for Transportation.

When the site construction is completed and an inspection for Certificate of Occupancy (C.O.) is requested, use the original City stamped approved TCL for certification. Redline any minor changes and adjustments that were made in the field. A NM registered architect or engineer must stamp, sign, and date the certification TCL along with indicating that the development was built in "substantial compliance" with the TCL. Submit this certification, the TCL, and a completed Drainage and Transportation Information Sheet to front counter personnel for log in and evaluation by Transportation.

Once verification of certification is completed and approved, notification will be made to Building Safety to issue Final C.O. To confirm that a final C.O. has been issued, call Building Safety at 924-3690.

Sincerely,

  
Nilo Salgado-Fernandez, P.E.  
Senior Traffic Engineer, Planning Dept.  
Development Review Services

C: CO Clerk, File

PO Box 1293

Albuquerque

NM 87103

www.cabq.gov



**VICINITY MAP**  
6800 Gonzales Rd SW, Albuquerque, NM 87121

**NOTE: ALL BROKEN OR CRACKED SIDEWALK MUST BE REPLACED WITH SIDEWALK AND CURB & GUTTER. REFER TO CITY STANDARD DRAWING 2430 & 2415A.**

**CODE DATA, PREPARATORY SCHOOL PORTABLE ADDITION AND PLAY FIELD IMPROVEMENTS:**

**PROJECT NAME:** MARK ARMIJO CHARTER SCHOOL, ADDITION TO SCHOOL WITH NEW PORTABLE.  
**UPC:** 101005651353110520  
**OWNER:** MARK ARMIJO FOUNDATION INC  
**OWNER ADDRESS:** 6800 GONZALES RD SW, ALBUQUERQUE, NM 87121  
**LEGAL DESCRIPTION:** LT 150-B PLAT OF LTS 150-A & 150-B TOWN OF ATRISCO GRANTUNIT 6  
**ZONE ATLAS MAP:** K-10-Z  
**ZONE CLASSIFICATION:** NR-BP

**EXECUTIVE SUMMARY FOR THE MARK ARMIJO CHARTER SCHOOL TCL PLAN:**

THE PROJECT IS LOCATED AT 6800 GONZALES RD IN THE SOUTHWEST QUADRANT OF ALBUQUERQUE. GONZALES RD ABUTS THE SITE TO THE NORTH, WITH COORS RD LOCATED WEST AND AIRPORT DR SOUTH.

THE CHARTER SCHOOL FACILITY IS THE MAIN PERMANENT STRUCTURE LOCATED ON THE SITE. THIS PROJECT INCLUDES THE RELOCATION AND INSTALLATION OF ONE, MODULAR CLASSROOM BUILDINGS (PORTABLE). IT WILL BE RELOCATED ON THE SITE SOUTH OF THE EXISTING ASPHALT PAVING USED FOR PARKING. RECENTLY TWO MODULAR CLASSROOMS WERE ADDED IN 2020.

TRAFFIC WOULD CONTINUE TO USE THE EXISTING SUCCESSFUL PARKING AND CIRCULATION LAYOUT AS IS. TWO-WAY TRAFFIC IS USED AT EVERY DRIVE LANE POSSIBLE TO EASE IN VEHICULAR SITE ACCESS, AND PEDESTRIAN FRIENDLY PATHS ONLY CROSS THESE TRAFFIC LANES AT PERPENDICULAR ANGLES.

THERE WILL BE NO IMPACT TO ADJACENT SITES. NO INCREASE IN STUDENTS, TEACHERS, PARENTS, TRAFFIC OR FUNCTIONS ARE EXPECTED AS PART OF THIS DEVELOPMENT. GONZALES AND COORS ROADWAYS ACT AS A BUFFER TO THE NORTH AND WEST OF THE SITE WITH TED GALLEGOS COMMUNITY CENTER SHARING PROPERTY LINES TO THE SOUTH. NO VARIANCES ARE BEING REQUESTED FOR THIS WORK. THIS IS AN ESTABLISHED SCHOOL FACILITY WITH EXISTING ACCESS POINTS AND AMPLE ON-SITE PARKING.

GROSS FLOOR CHANGE CALCULATIONS		
GROSS BUILDING AREA	16,545 SF	
CAFETERIA	3,324 SF	
2,268 SF / 15 NET = 151 OCC.		
PORTABLE ADDITION	1,641 SF	
GROSS BUILDING CHANGE	9.9% CHANGE	
REQUIREMENTS (BASED ON 151 OCC)		
PARKINGS SPACES	1 SPACE FOR EA. 4 SEATS IN CAFETERIA	38
CREDITS		
10% FOR PUBLIC BUS STOP NEARBY		
38 * 1 = 4		
ADA SPACES REQUIRED	(FOR 26 TO 35 PARKING SPACES)	2
ADA VAN SPACES	(1 FOR EA. OF 2 ADA SPACES)	1
BICYCLE SPACES	(1 SPACE FOR EA. 50 STUDENTS)	4
MOTORCYCLE SPACES	(FOR 26 TO 50 PARKING SPACES)	2
PROVIDED		
TOTAL SPACES		51
ADA SPACES PROVIDED		3
ADA VAN SPACES		2
BICYCLE RACK (EXISTING)		4
MOTORCYCLE SPACES PROVIDED		2

VALUE	DESCRIPTION
501	EXISTING ASPHALT PAVING TO REMAIN, PATCH AND REPAIR AS NECESSARY TO PERFORM NEW WORK.
502	EXISTING CHAIN-LINK FENCE TO REMAIN.
503	EXISTING CONCRETE SIDEWALK TO REMAIN, PATCH AND REPAIR AS NECESSARY TO PERFORM NEW WORK.
504	EXISTING OVERHEAD UTILITY LINE. SEE SURVEY. SEE ELECTRICAL.
505	EXISTING TREES AND LANDSCAPING TO REMAIN. PROTECT DAMAGE SHALL BE REPAIRED OR REPLACED AT NO COST TO THE OWNER.
507	NEW ADA RAMP AND LANDING BY BUILDING MANUFACTURE.
506	RESTRIPED PARKING SPACE FOR ADA ACCESSIBLE PARKING AT ALL.
508	NEW CONCRETE PAVED SIDEWALK SEE DETAIL 02/TCL-102.
510	NEW METACONCRETE PAVED SIDEWALK EXTENSION.

**TRAFFIC CIRCULATION LAYOUT APPROVED**  
 Signed: [Signature]  
 Date: 8/31/21

8/30/2021 4:18:09 PM  
 A1

**TCL SITE PLAN**  
 1" = 30'-0"

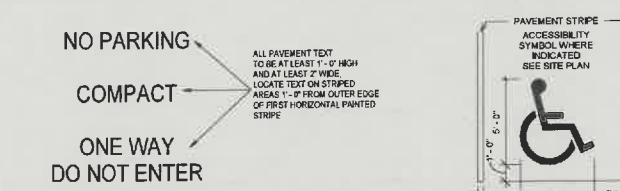
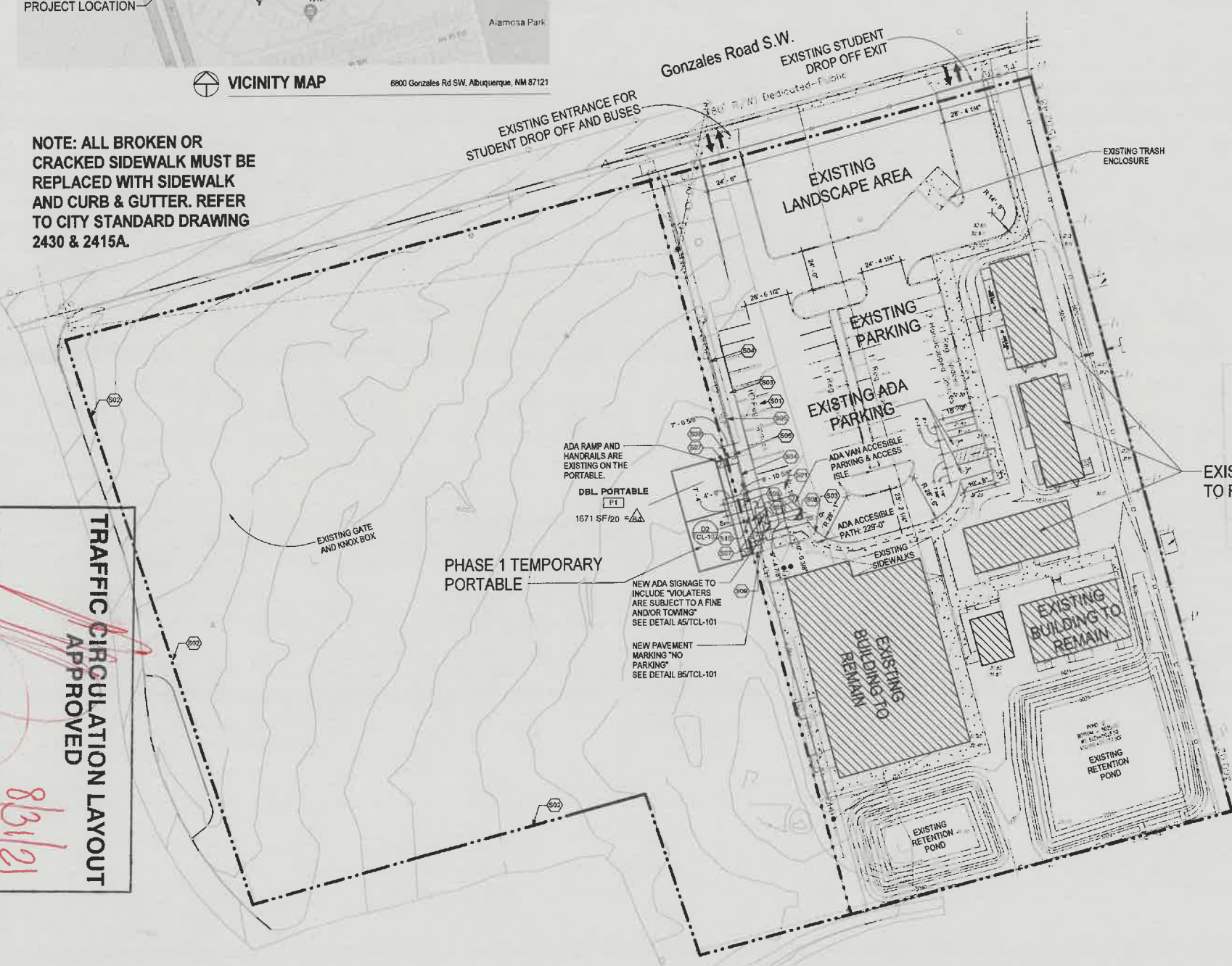

**B5 PAVEMENT SIGNAGE**  
 1/4" = 1'-0"

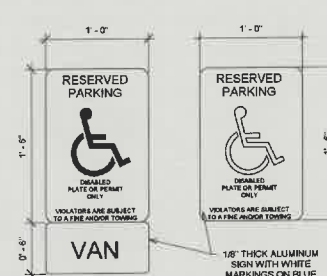

**A5 SIGNAGE**  
 1 1/2" = 1'-0"

**B6 PAVEMENT MARKING**  
 1/4" = 1'-0"

**fbt architects**  
 6501 Americas Pkwy NE., Ste. 300  
 Albuquerque, NM 87110  
 P\_505.883.5200 WEB: www.fbtarch.com

**CONSULTANTS**

**STRUCTURAL**  
 Walls Engineering  
 6501 Americas Parkway, Ste 301  
 Albuquerque, NM 87110  
 p\_505.881.3008

**CIVIL**  
 Miller Engineering Consultants  
 3500 Comanche NE, Bldg F  
 Albuquerque, NM 87107  
 p\_505.888.7500

**M/E/P/F/P**  
 Bridgers and Paxton  
 4600 C Montgomery  
 Albuquerque, NM 87109  
 p\_505.883.4111

**ARCHITECT**

**Mark Armijo ACADEMY**  
**Mark Armijo Academy - Site Development Plan**

**CONSTRUCTION DOCUMENTS**  
 6800 Gonzales Rd SW  
 Albuquerque, NM 87121  
 JUNE 2021

MARK	DATE	DESCRIPTION

ISSUE	CONSTRUCTION
DATE:	DATE:
PROJECT NO:	Project Number
DRAWN BY:	Author
CHECKED BY:	Checker

**TCL-101**

L10-0007A

1 TCL SITE PLAN ENLARGED

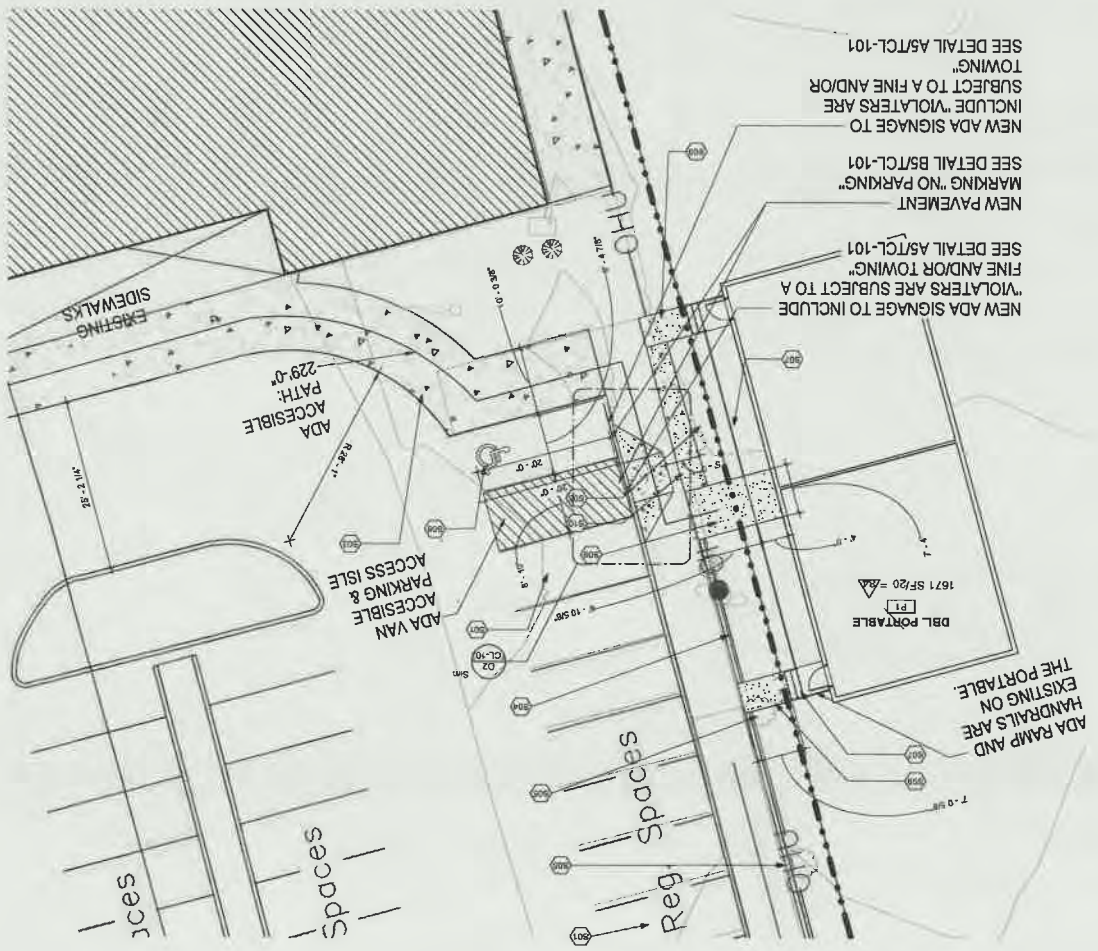

D1 Concrete Pavement

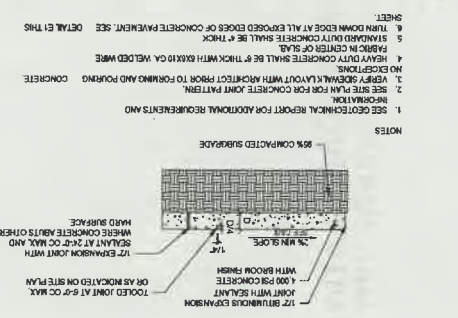

D2 CONCRETE CURB RAMP

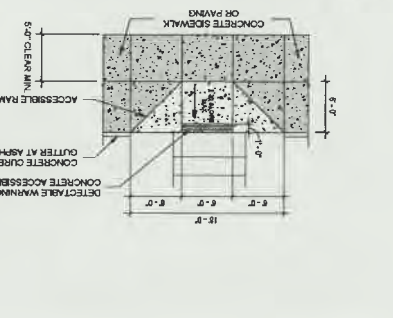

VALUE	DESCRIPTION
501	EXISTING ASPHALT FINISH TO REMAIN PATCH AND REPAIR AS NECESSARY
502	REMOVE CONCRETE SIGNAGE TO REMAIN PATCH AND REPAIR AS NECESSARY TO PERFORM NEW WORK
503	REMOVE CONCRETE SIGNAGE TO REMAIN PATCH AND REPAIR AS NECESSARY TO PERFORM NEW WORK
504	EXISTING OVERHEAD UTILITIES SEE ELECTRICAL
505	REMOVE EXISTING ASPHALT AND REPAIR AS NECESSARY TO PERFORM NEW WORK
506	REMOVE EXISTING ASPHALT AND REPAIR AS NECESSARY TO PERFORM NEW WORK
507	REMOVE EXISTING ASPHALT AND REPAIR AS NECESSARY TO PERFORM NEW WORK
508	REMOVE EXISTING ASPHALT AND REPAIR AS NECESSARY TO PERFORM NEW WORK
509	REMOVE EXISTING ASPHALT AND REPAIR AS NECESSARY TO PERFORM NEW WORK
510	REMOVE EXISTING ASPHALT AND REPAIR AS NECESSARY TO PERFORM NEW WORK

**TRAFFIC CIRCULATION LAYOUT APPROVED**  
 Signed: *[Signature]*  
 Date: 8/31/21

**CONSULTANTS**  
 6501 Americas Pkwy NE, Ste. 300  
 Albuquerque, NM 87110  
 P: 505.883.5200 WEB: www.fbtarch.com

**STRUCTURAL**  
 Wills Engineering  
 5501 Americas Parkway, Ste 301  
 Albuquerque, NM 87110  
 P: 505.861.3008

**CIVIL**  
 Miller Engineering Consultants  
 3500 Comanche NE, Bldg F  
 Albuquerque, NM 87107  
 P: 505.888.7500

**ME/PE/FP**  
 Bridges and Paxton  
 4600 C Montgomery  
 Albuquerque, NM 87108  
 P: 505.883.4111

**ARCHITECT**  
 Mark Armijo Academy  
 STATE OF NEW MEXICO  
 REGISTERED ARCHITECT  
 No. 1008  
 04/09/21

**CONSTRUCTION DOCUMENTS**  
 Mark Armijo Academy - Site Development Plan  
 6800 Gonzales Rd SW  
 Albuquerque, NM 87121  
 JUNE 2021

**TRAFFIC CIRCULATION LAYOUT**  
 SHEET TITLE  
 CONSTRUCTION DATE  
 PROJECT NO.  
 DRAWN BY  
 CHECKED BY

**TCL-102**

L10-D007A