



DEVELOPMENT REVIEW BOARD
SUPPLEMENTAL SUBMITTAL

(Deadline is Friday at noon unless noted on 2019 agenda – late submittals will not be accepted unless approved by the DRB)

PROJECT NO. PR-2021-005717
Application No. SD-2021-00162, VA-2021-00310

TO:

Planning Department/Chair

Hydrology

Transportation Development

Albuquerque/ Bernalillo Co. WUA

Code Enforcement

*(Please attach this sheet with each collated set for each board member)

NOTE: ELECTRONIC VERSION (ie disk, thumbdrive) is Required. Submittal will not be accepted without.

DRB SCHEDULED HEARING DATE: 12/08/2021 HEARING DATE OF DEFERRAL: 12/15/2021

SUBMITTAL DESCRIPTION: Re-submittal to address comments

CONTACT NAME: Jeremy Shell

TELEPHONE: 505.918.1053 EMAIL: jeremy.shell@respec.com

PRELIMINARY PLAT FOR
VOLCANO MESA AT THE TRAILS
LOTS 1-72 AND TRACTS A-G

SEPTEMBER 2021

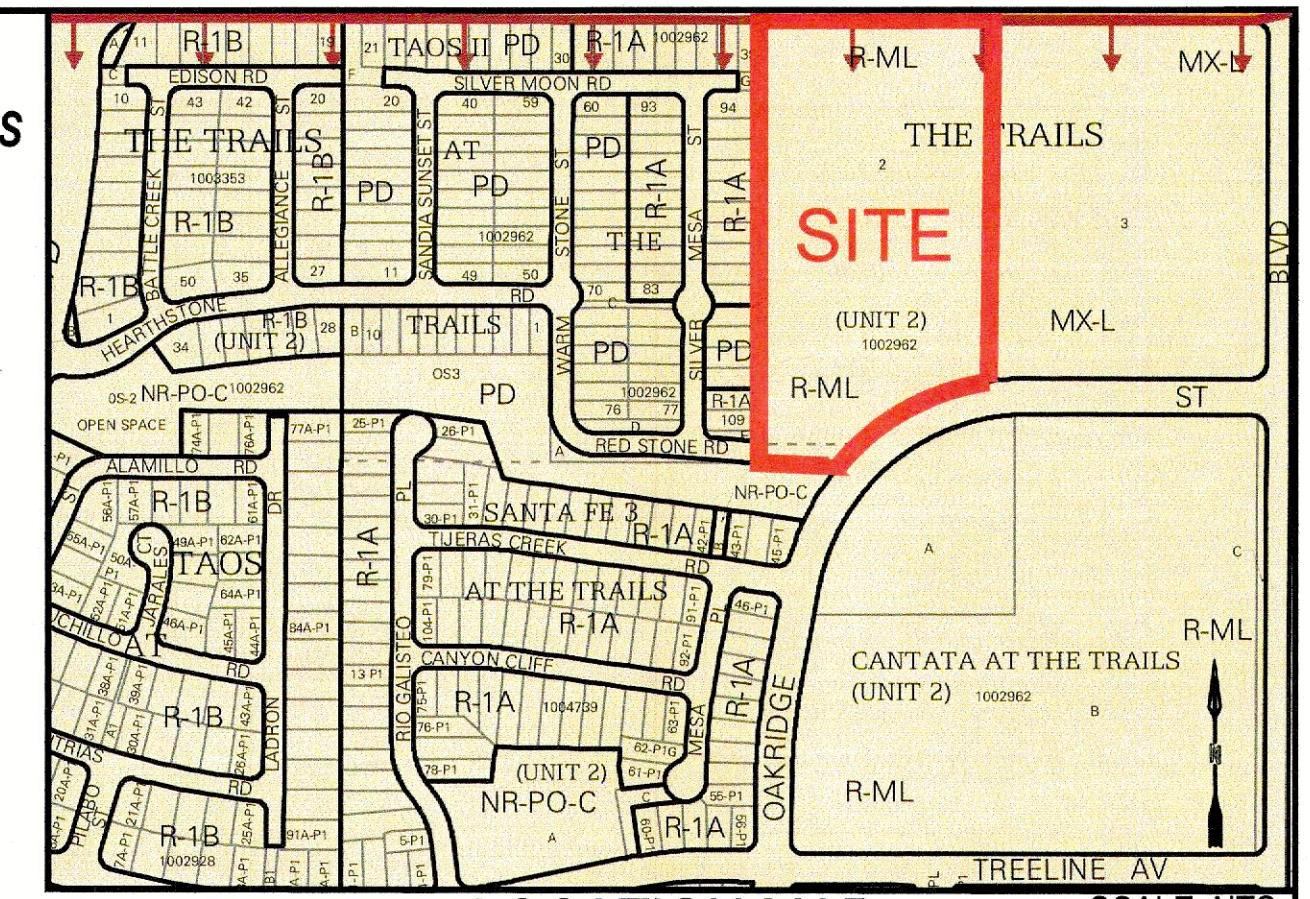

LOCATION MAP
ZONE ATLAS MAP C-09-Z
SCALE: NTS

RECORD AND MEASURED LEGAL DESCRIPTION

TRACT NUMBERED TWO (2), OF THE TRAILS UNIT 2, AS THE SAME IS SHOWN AND DESIGNATED ON THE PLAT ENTITLED, "BULK LAND PLAT OF THE TRAILS UNIT 2 (BEING A REPLAT OF TRACTS G AND J, THE TRAILS AND UNPLATTED DEED PARCELS) WITHIN THE TOWN OF ALAMEDA GRANT, IN PROJECTED SECTION SECTION 16, TOWNSHIP 11 NORTH, RANGE 2 EAST, NEW MEXICO PRINCIPAL MERIDIAN, CITY OF ALBUQUERQUE, BERNALILLO COUNTY, NEW MEXICO, AUGUST 2004", FILED IN THE OFFICE OF THE COUNTY CLERK OF BERNALILLO COUNTY, NEW MEXICO ON OCTOBER 19, 2004 IN PLAT BOOK 2004C, PAGE 332.

GENERAL NOTES

- EXISTING ZONING: R-ML - MULTI-FAMILY - LOW DENSITY
- A PROPOSED ZONING: MULTI-FAMILY - LOW DENSITY
- PROPOSED AREA: 10.4 AC
NUMBER OF LOTS: 72
NUMBER OF TRACTS: 7
PROPOSED DENSITY: 6.9 DU/AC
- MIN. LOT DIMENSIONS: 40' X 105'
MIN. LOT AREA: 4,200 SQFT
- ALL STREETS, UTILITIES, AND STORM DRAIN IMPROVEMENTS ARE TO BE PUBLIC AND TO BE DEDICATED TO THE CITY OF ALBUQUERQUE FOR MAINTENANCE.
- LOT SETBACKS SHALL CONFORM TO THE INTEGRATED DEVELOPMENT ORDINANCE.
- NO LOTS SHALL HAVE DIRECT ACCESS TO PASEO DEL NORTE BLVD.
- TRACTS A-G TO BE OWNED AND MAINTAINED BY THE HOME OWNERS ASSOCIATION

SIDE DATA

ZONE ATLAS NO.	C-09-Z
ZONING	R-ML
MILES OF FULL WIDTH STREET CREATED	0.39 MILE
NO. OF EXISTING TRACTS	1
NO. OF LOTS CREATED	72
NO. OF HOA TRACTS CREATED	7

EASEMENT NOTES

- EXISTING 40' PRIVATE ACCESS AND PUBLIC DRAINAGE AND UTILITY EASEMENT (10/18/2004, 2004C-332)
- EXISTING 20' PNM EASEMENT (3/23/2004, BK. A74, PG. 7747, DOC. NO. 2004037858) AS SHOWN ON THE PLAT (10/18/2004, 2004C-332)
- EXISTING 10' P.U.E. (11/09/2017, 2017C-124)
- EXISTING 20' WATER EASEMENT GRANTED TO ABCWUA (11/09/2017, 2017C-124)
- EXISTING BLANKET PRIVATE ACCESS, DRAINAGE AND SANITARY SEWER EASEMENT, ACROSS TRACT G (11/09/2017, 2017C-124)
- NEW BLANKET WATER EASEMENT GRANTED TO ABCWUA WITH THIS PLAT.
- NEW BLANKET SANITARY SEWER EASEMENT GRANTED TO ABCWUA WITH THIS PLAT.
- NEW BLANKET PUBLIC PEDESTRIAN ACCESS EASEMENT.
- NEW BLANKET DRAINAGE AND STORM DRAIN EASEMENT GRANTED TO THE CITY OF ALBUQUERQUE WITH THIS PLAT.
- PORTION OF EXISTING 40' PRIVATE ACCESS AND PUBLIC DRAINAGE AND UTILITY EASEMENT TO THE VACATED BY THIS PLAT.

ACS Monument "2-C9"
NAD 1983 CENTRAL ZONE
X=1494519.241
Y=1521672.052
Z=5454.55 (NAVD 1988)
G-G=0.999666850
Mapping Angle = -0°16'52.77"

ACS Monument "2-B10"
NAD 1983 CENTRAL ZONE
X=1497789.569
Y=1528038.78
Z=5432.168 (NAVD 1988)
G-G=0.999667416
Mapping Angle = -0°16'30.71"

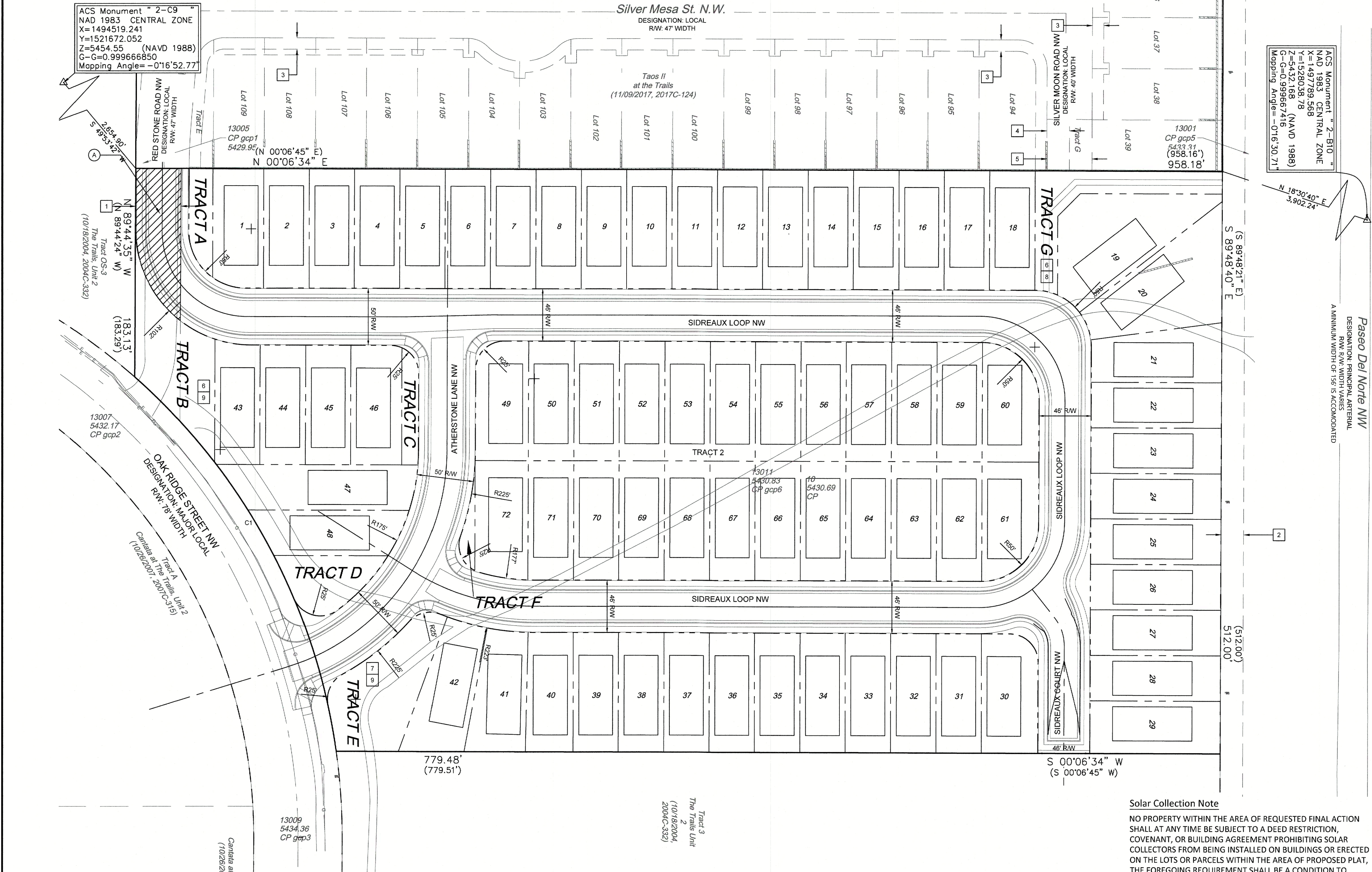

- SURVEY NOTES**
- ALL BOUNDARY CORNERS SHOWN (● / ○) ARE FOUND REBAR W/CAP.
 - ALL STREET CENTERLINE MONUMENTATION SHALL BE INSTALLED AT ALL CENTERLINE PC'S, PTS, ANGLE POINTS, AND STREET INTERSECTIONS AND SHOWN THUS (▲), AND WILL BE MARKED BY (4") ALUMINUM CAP STAMPED "CITY OF ALBUQUERQUE" CENTERLINE MONUMENTATION MARKED, DO NOT DISTURB PLS 9750".
 - THE SUBDIVISION BOUNDARY WILL BE TIED TO THE NEW MEXICO STATE PLANE COORDINATE SYSTEM AS SHOWN.
 - BASIS OF BEARINGS WILL BE NEW MEXICO STATE PLANE BEARINGS.
 - DISTANCES SHALL BE GROUND DISTANCES.
 - MANHOLES WILL BE OFFSET AT ALL POINTS OF CURVATURE, TANGENCY STREET INTERSECTIONS, AND ALL OTHER ANGLE POINTS TO ALLOW USE OF CENTERLINE MONUMENTATION.

LEGEND
 ——— SUBDIVISION BOUNDARY LINE
 - - - PROPERTY LINE

Solar Collection Note
 NO PROPERTY WITHIN THE AREA OF REQUESTED FINAL ACTION SHALL AT ANY TIME BE SUBJECT TO A DEED RESTRICTION, COVENANT, OR BUILDING AGREEMENT PROHIBITING SOLAR COLLECTORS FROM BEING INSTALLED ON BUILDINGS OR ERECTED ON THE LOTS OR PARCELS WITHIN THE AREA OF PROPOSED PLAT, THE FOREGOING REQUIREMENT SHALL BE A CONDITION TO APPROVAL OF THIS PLAT.

APPROVED
 Loren W. Rasmussen, P.S.
 CITY SURVEYOR
 DATE 9/20/2021

(Signature)
 TONYA BUXTON
 ALBUQUERQUE DIVISION PRESIDENT, DR HORTON
 DATE 11.30.21

CURVE TABLE

CURVE #	LENGTH	RADIUS	DELTA	CHORD LENGTH	CHORD DIRECTION
C1	381.96' (381.94')	539.00' (539.00')	40°36'08"	374.02'	S 61°36'52" W

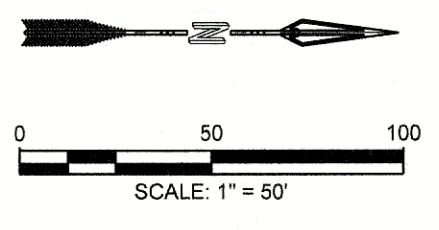

Benchmark -NAVD 88
 ACS MONUMENT "2-C9" HAVING AN ELEVATION OF 5454.55.

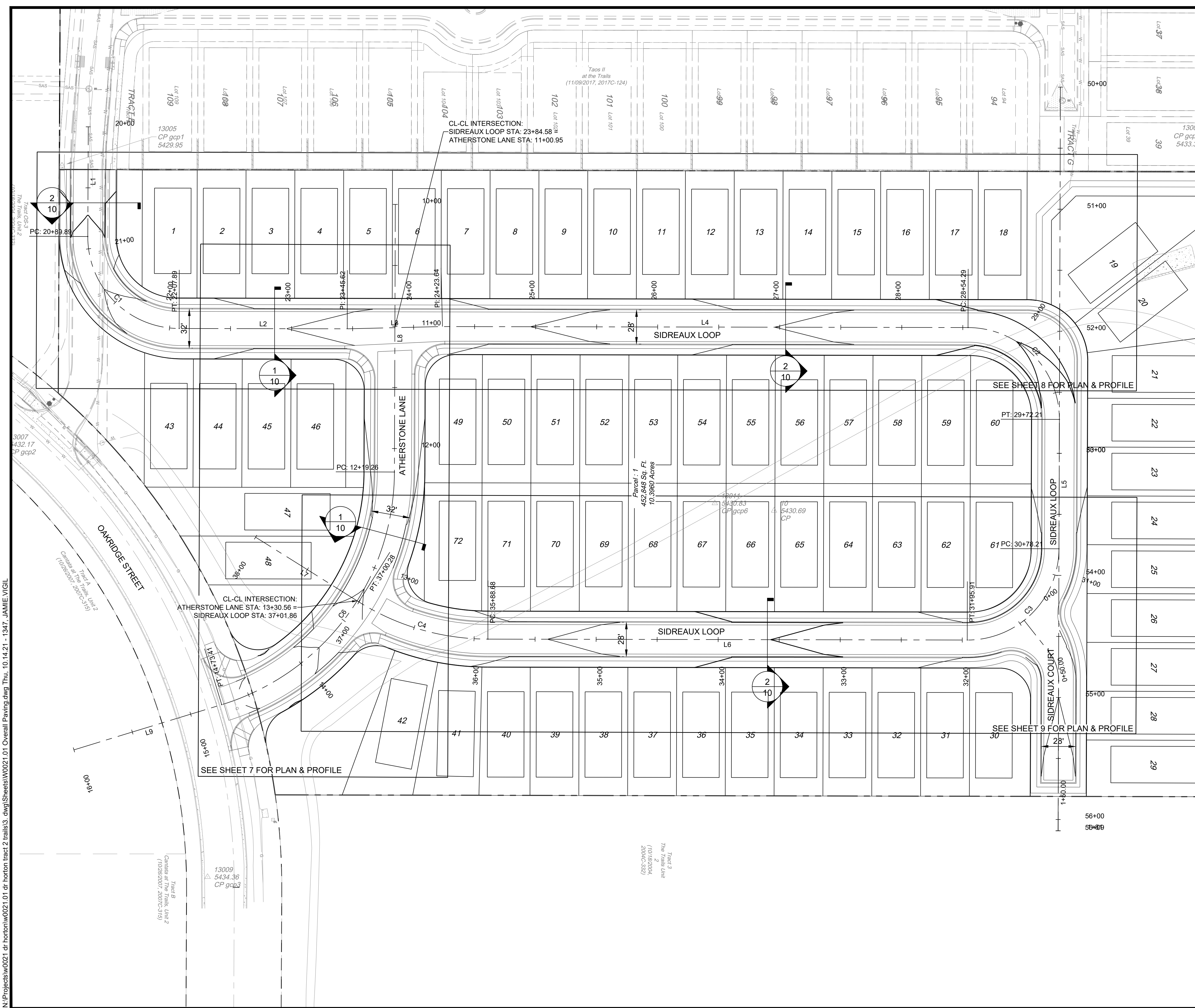

ATHERSTONE LANE			
NUMBER	LENGTH	RADIUS	LINE/CHORD DIRECTION
L8	219.258		S89° 48' 31.05"E
C6	254.148	200.000	S53° 24' 16.61"E
L9	126.594		S17° 00' 02.16"E

SIDREAUX LOOP			
NUMBER	LENGTH	RADIUS	LINE/CHORD DIRECTION
L1	89.888		S89° 11' 00.00"E
C1	118.003	75.000	N45° 11' 00.00"E
L2	137.726		N00° 06' 34.37"E
L3	78.026		N01° 21' 33.30"W
L4	430.650		N00° 06' 34.37"E
C2	117.919	75.000	N45° 09' 04.05"E
L5	106.000		S89° 48' 26.27"E
C3	117.701	75.000	S44° 50' 55.95"E
L6	392.770		S00° 06' 34.37"W
C4	111.595	200.000	S16° 05' 39.56"W
L7	99.724		S32° 04' 44.75"W

- NOTES:**
- CURB AND GUTTER, SIDEWALKS, AND DRIVE PADS SHALL MATCH THE ELEVATIONS OF ABUTTING EXISTING AREAS AS SHOWN ON THE PLANS OR AS DIRECTED BY THE PROJECT ENGINEER.
 - THE SUBGRADE PREP SHALL EXTEND ONE FOOT BEYOND THE FREE EDGE OF NEW CURB AND GUTTER AND SIDEWALK.
 - CONTRACTOR TO TEST SUBGRADE R-VALUE PRIOR TO CONSTRUCTION. IN THE EVENT THE R-VALUE IS LESS THAN 50, REMOVE 2 FEET OF SUBGRADE MATERIAL AND IMPORT MATERIAL WITH R-VALUE GREATER THAN 50 OR CONTACT THE ENGINEER IMMEDIATELY SO THE PAVEMENT SECTION CAN BE MODIFIED.

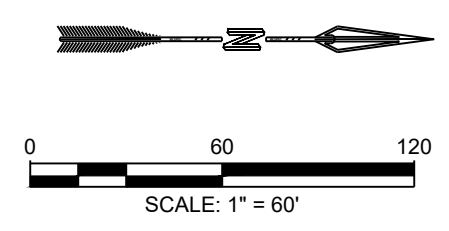

RESPEC
 COMMUNITY DESIGN SOLUTIONS
 5971 JEFFERSON STREET SUITE 101
 ALBUQUERQUE, NEW MEXICO 87109
 WWW.RESPEC.COM PHONE: (505)253-9718

CITY OF ALBUQUERQUE
 DEPARTMENT OF MUNICIPAL DEVELOPMENT
 ENGINEERING DIVISION

VOLCANO MESA AT THE TRAILS
 OVERALL ROADWAY PLAN

Design Review Committee	City Engineer Approval	Mo./Day/Yr.	Mo./Day/Yr.
Last Design Update			

Project No. XXXXXX Zone Map No. C-9-Z Sheet 6 of 20

AS BUILT INFORMATION

CONTRACTOR	DATE
ALBUQUERQUE CONTROL SURVEY <td></td>	
INSPECTORS	DATE
MONUMENT UNION NEW MEXICO <td></td>	
FIELD CHANGES BY	DATE
STATE PLANE COORDINATES (CENTRAL) <td></td>	
VERIFICATION BY	DATE
ZONE - NAD 83 <td></td>	
CORRECTED BY	DATE
NORTH = 1,523,503.475 FEET <td></td>	
MICRO-FILM INFORMATION	DATE
EAST = 1,493,655.03 FEET <td></td>	
MAPPING ANGLE = -00°16'58.96" <td></td>	
GROUND TO GRID FACTOR = 0.99666436 <td></td>	
ELEVATION = 5524.95 FEET <td></td>	

BENCH MARKS

ALBUQUERQUE CONTROL SURVEY	DATE
MONUMENT UNION NEW MEXICO	
STATE PLANE COORDINATES (CENTRAL)	DATE
ZONE - NAD 83	
NORTH = 1,523,503.475 FEET	DATE
EAST = 1,493,655.03 FEET	
MAPPING ANGLE = -00°16'58.96"	DATE
GROUND TO GRID FACTOR = 0.99666436	
ELEVATION = 5524.95 FEET	

ENGINEER'S SEAL

90% REVIEW

PRELIMINARY
 NOT FOR CONSTRUCTION
 10.2021

NO.	DATE	REVISIONS	BY
		RESPEC DESIGN <td></td>	
DESIGNED BY:	DATE: 10.14.2021		
DRAWN BY: RESPEC	DATE: 10.14.2021		
CHECKED BY: SEG	DATE: 10.14.2021		

N:\Projects\w0021 dr horton\w0021.01 dr horton\w0021.01 Overall Paving.dwg Thu, 10/14/21 - 1347 - JAMIE VIGIL

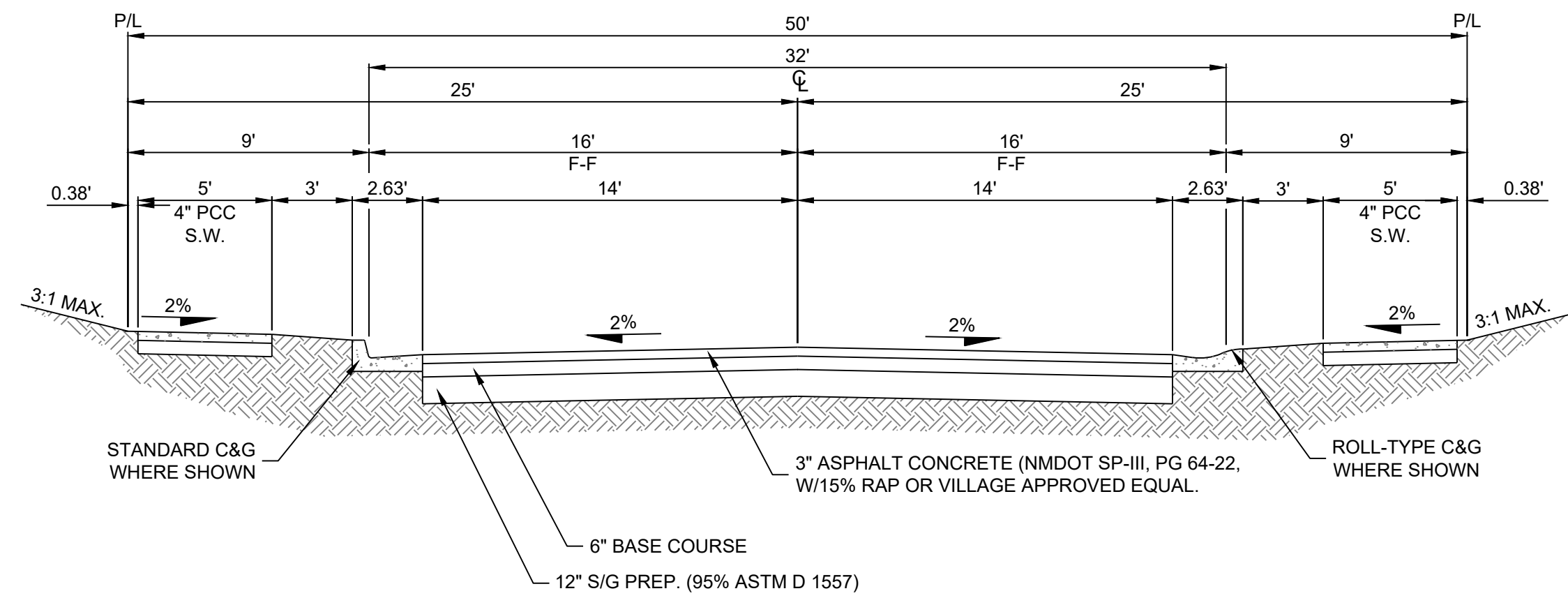

1
10 TYPICAL 32' STREET SECTION
NOT TO SCALE

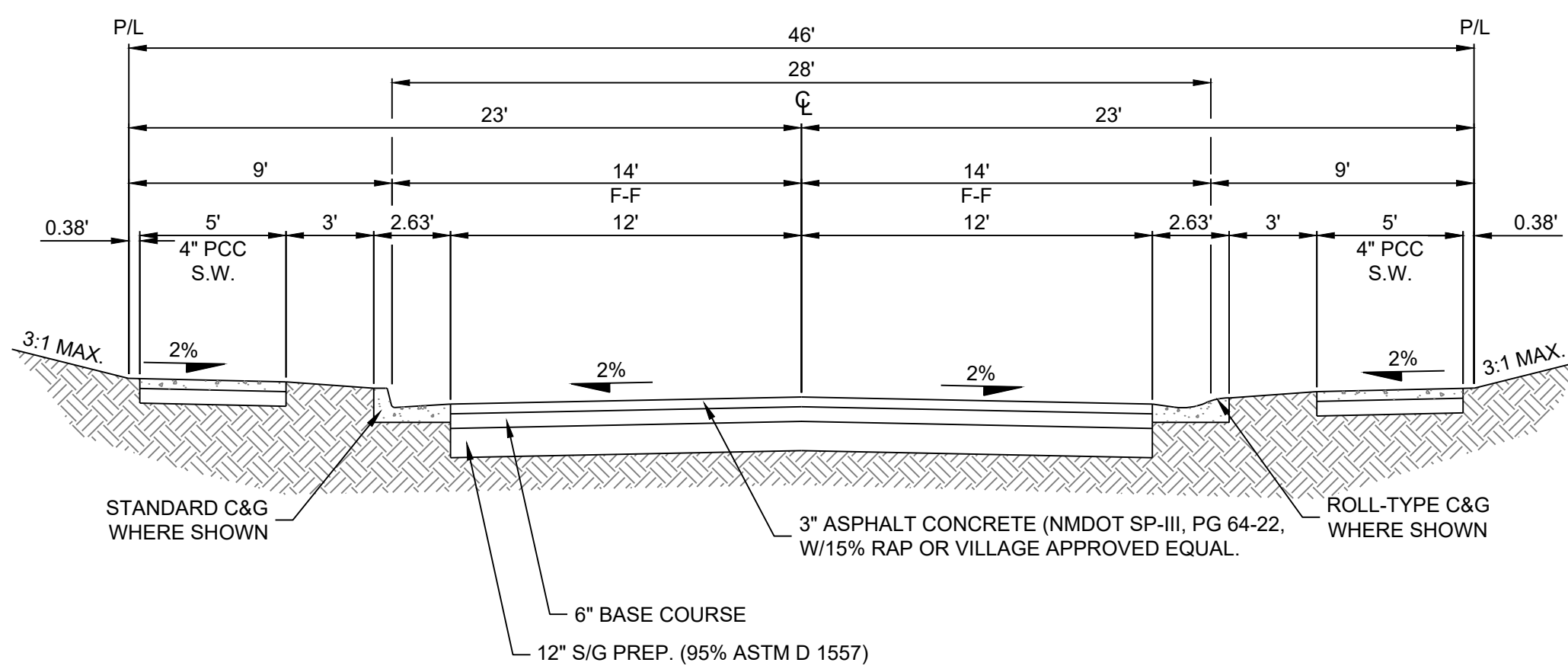

2
10 TYPICAL 28' STREET SECTION
NOT TO SCALE

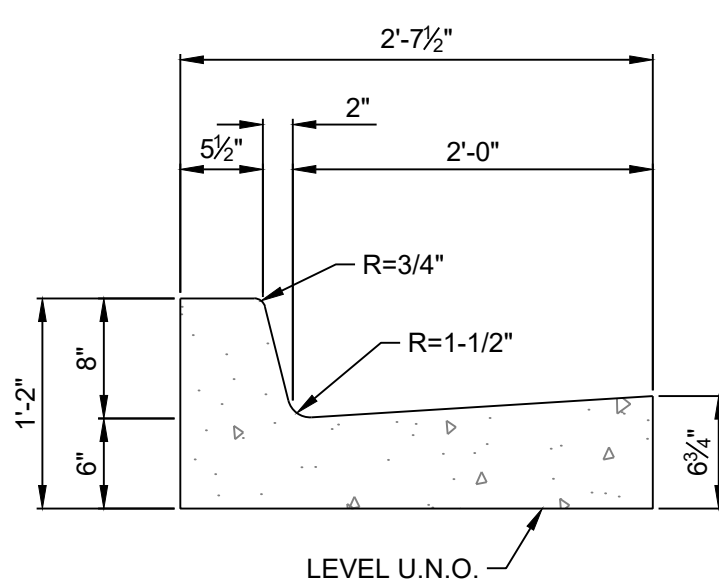

STANDARD CURB & GUTTER
NO SCALE

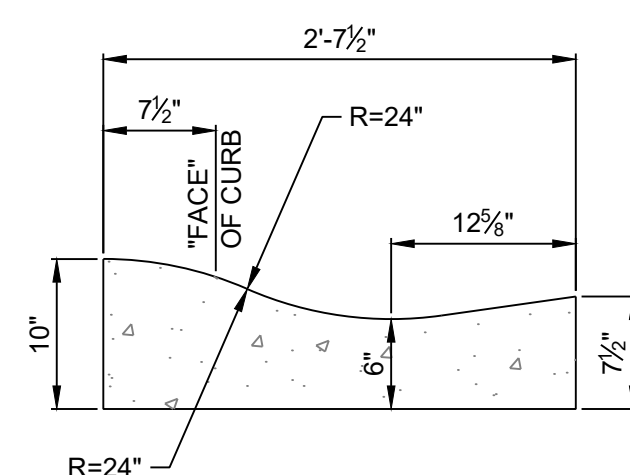

ROLL-TYPE CURB & GUTTER
NO SCALE

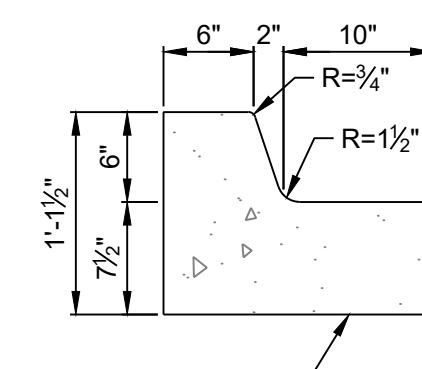

MEDIAN CURB & GUTTER
NO SCALE

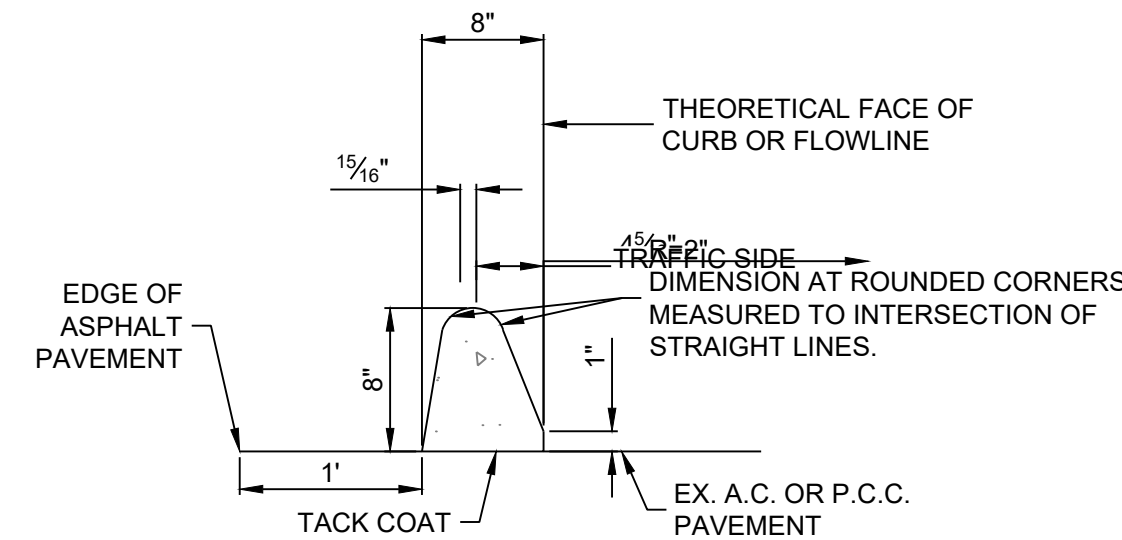

ASPHALT CURB
NO SCALE

N:\Projects\w0021 dr horizon\w0021.01 dr horizon\trac2 trails\31.dwg\Sheets\W0021.01 Typical Roadway Sections.dwg Thu, 10/14/21 - 13:48 JAMIE VIGIL

© Copyright 2021 RESPEC - All Rights Reserved

AS BUILT INFORMATION	
CONTRACTOR	ALBUQUERQUE CONTROL SURVEY
STAKED BY	MONUMENT UNION NEW MEXICO
INSPECTORS	STATE PLANE COORDINATES (CENTRAL
FIELD CHANGE BY	ZONE - NAD 83
DATE	NORTH = 1,523,503.475 FEET
DATE	EAST = 1,493,655.03 FEET
DATE	MAPPING ANGLE = -00°16'58.96"
DATE	GROUND TO GRID FACTOR = 0.99666436
DATE	ELEVATION = 5624.95 FEET

BENCHMARKS	
ALBUQUERQUE CONTROL SURVEY	
MONUMENT UNION NEW MEXICO	
STATE PLANE COORDINATES (CENTRAL	
ZONE - NAD 83	
NORTH = 1,523,503.475 FEET	
EAST = 1,493,655.03 FEET	
MAPPING ANGLE = -00°16'58.96"	
GROUND TO GRID FACTOR = 0.99666436	
ELEVATION = 5624.95 FEET	

SURVEY INFORMATION	
FIELD NOTES	DATE
NO.	BY

90% REVIEW

PRELIMINARY
NOT FOR CONSTRUCTION
10.2021

ENGINEER'S SEAL	
REMARKS	BY
REVISIONS	DATE
RESPEC DESIGN	DATE
DESIGNED BY: JWS	DATE: 10/14/2021
DRAWN BY: JMT	DATE: 10/14/2021
CHECKED BY: SEG	DATE: 10/14/2021

RESPEC
COMMUNITY DESIGN SOLUTIONS
5971 JEFFERSON STREET SUITE 101
ALBUQUERQUE, NEW MEXICO 87109
WWW.RESPEC.COM PHONE: (505)253-9718

CITY OF ALBUQUERQUE
DEPARTMENT OF MUNICIPAL DEVELOPMENT
ENGINEERING DIVISION

VOLCANO MESA AT THE TRAILS
TYPICAL ROADWAY SECTIONS

Design Review Committee	City Engineer Approval	Mo./Day/Yr.	Mo./Day/Yr.
Last Design Update			

Project No. XXXXXX Zone Map No. C-9-Z Sheet 10 of 20

N:\Projects\W0021_01.dwg\horton\trac2\trails3.dwg\Sheets\W0021_01 Sidreaux Loop Plan & Profile.dwg Thu, 10/14/21 - 13:49 - JAMIE.VIGIL

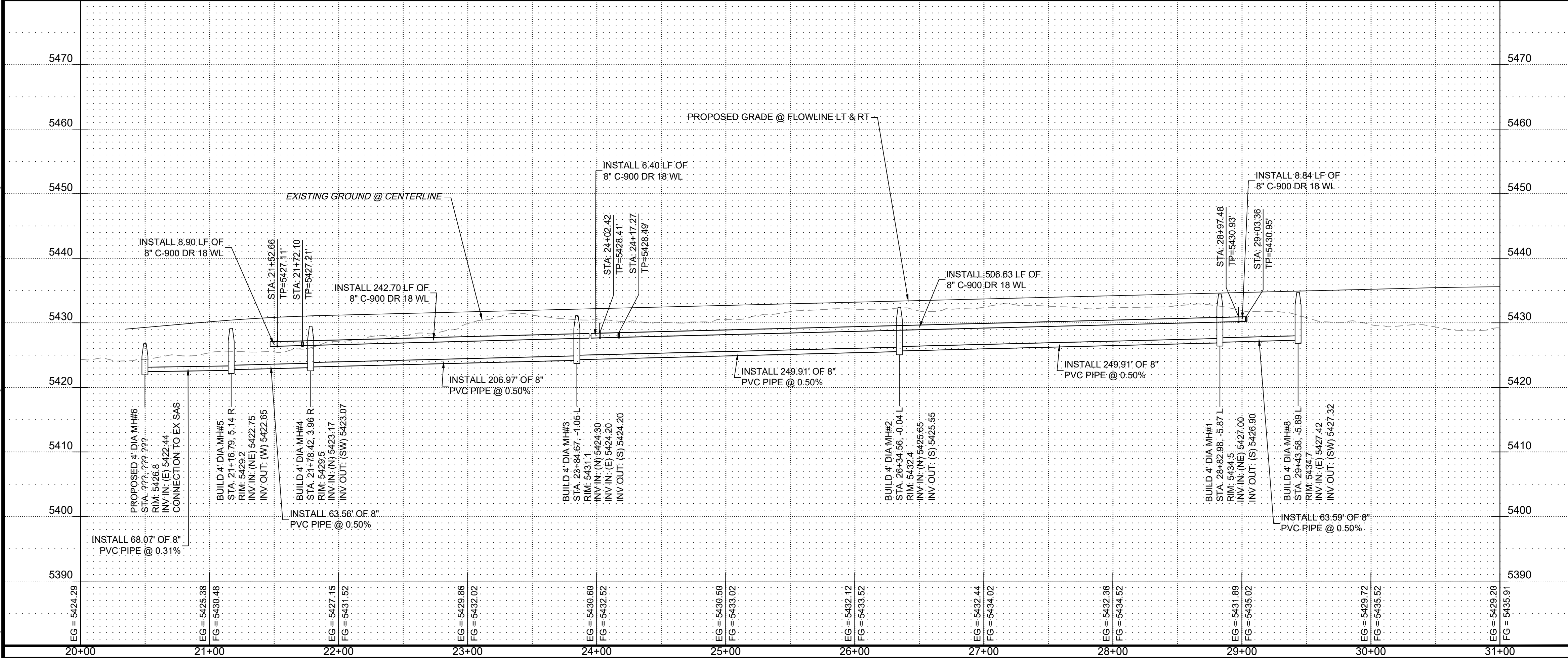
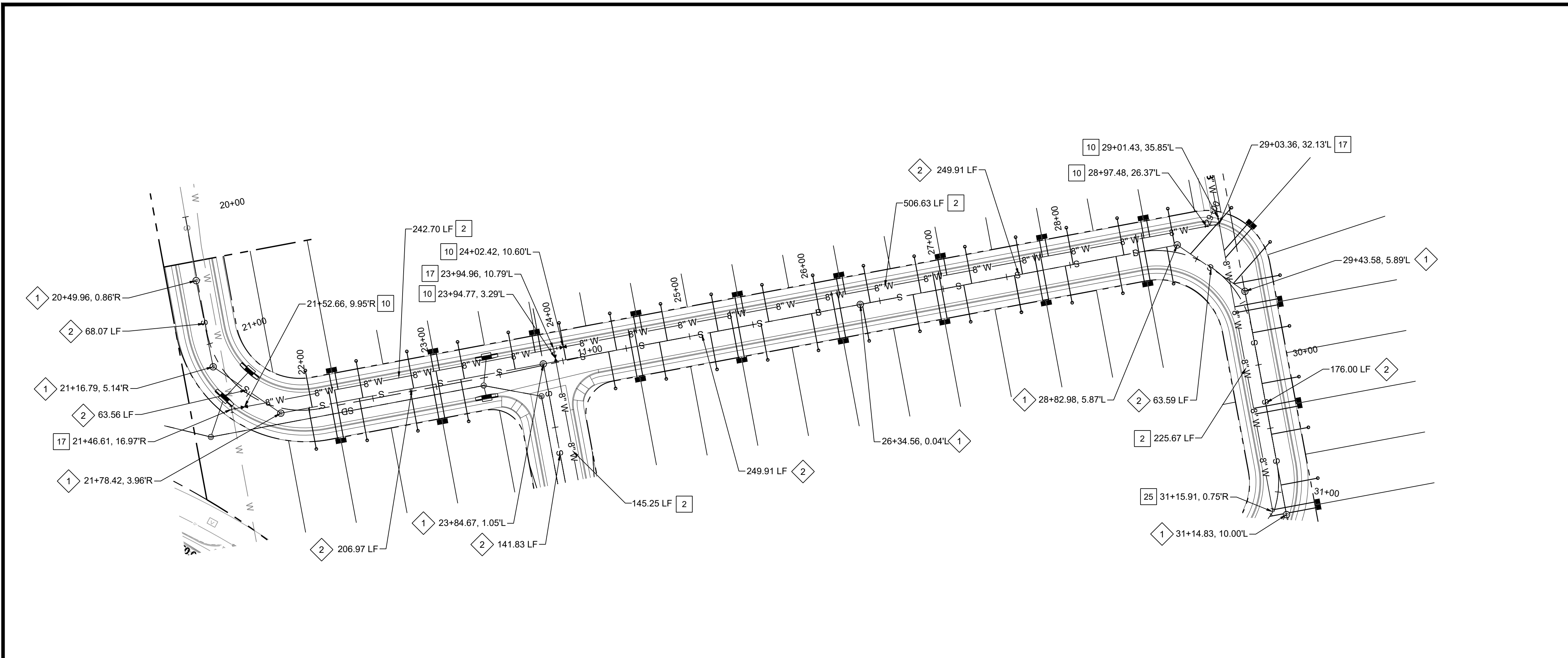

WATER CONSTRUCTION NOTES	
I.D.#	DESCRIPTION
1	INSTALL 6" WATERLINE PER STD. SPEC. SEC. 801
2	INSTALL 8" WATERLINE PER STD. SPEC. SEC. 801
3	INSTALL 10" WATERLINE PER STD. SPEC. SEC. 801
4	INSTALL 6" CAP
5	INSTALL 8" x 6" TEE
6	INSTALL 8" 11.25" BEND
7	INSTALL 10" 90" BEND
8	"MEG A LUG" ALL FITTINGS AND JOINTS FROM TEE TO FIRE HYDRANT
9	INSTALL 6" GATE VALVE AND VALVE BOX, PER COA STD. DTL. 2326, 2328, AND/OR 2329
10	INSTALL 8" GATE VALVE AND VALVE BOX, PER COA STD. DTL. 2326, 2328
11	INSTALL FIRE HYDRANT, PER COA STD. DTL. 2340
12	INSTALL 4" WATERLINE PER STD. SPEC. SEC. 801
13	INSTALL 8" CAP
14	INSTALL 10" CROSS
15	INSTALL 6" CAP
16	INSTALL 4" GATE VALVE AND VALVE BOX, PER COA STD. DTL. 2326, 2328
17	INSTALL 8" x 8" TEE
18	INSTALL 10" CAP
19	INSTALL 10" x 6" TEE
20	INSTALL 10" TEE
21	INSTALL 12" x 8" TEE
22	INSTALL 10" x 8" TEE
23	INSTALL 10" GATE VALVE AND VALVE BOX, PER COA STD. DTL. 2326, 2328
24	INSTALL 10" x 4" TEE
25	INSTALL 4" WATERLINE PER STD. SPEC. SEC. 801
26	INSTALL LARGE DIAMETER METER VAULT 3" SERVICE PER COA STD. DTL. 2370.
27	INSTALL 10" 45" BEND
28	INSTALL 8" 45" BEND

SANITARY SEWER CONSTRUCTION NOTES	
I.D.#	DESCRIPTION
1	INSTALL SEWER MANHOLE TYPE "E", PER COA STD. DTL. 2102
2	INSTALL 8" SEWER PER STD. SPEC. SEC. 901
3	INSTALL 8" CAP

- NOTES:**
- CONTRACTOR TO FIELD VERIFY ALL EXISTING UTILITY LOCATIONS AND DEPTHS PRIOR TO ANY CONSTRUCTION.
 - SEE SHEET 29 OF ## FOR JOINT TABLE RESTRAINT REQUIREMENTS.

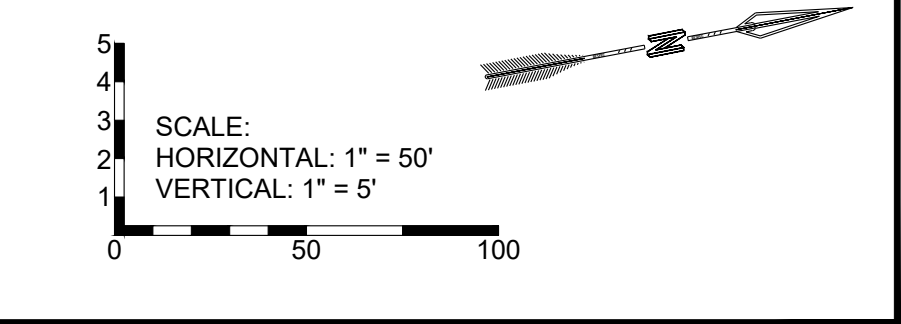

RESPEC
 COMMUNITY DESIGN SOLUTIONS
 597 JEFFERSON STREET SUITE 101
 ALBUQUERQUE, NEW MEXICO 87109
 WWW.RESPEC.COM PHONE: (505)253-9718

CITY OF ALBUQUERQUE
 DEPARTMENT OF MUNICIPAL DEVELOPMENT
 ENGINEERING DIVISION

THE TRAILS TRACT 2
 SIDREAUX LOOP PLAN & PROFILE

Design Review Committee	City Engineer Approval	Mo./Day/Yr.	Mo./Day/Yr.

AS BUILT INFORMATION			
CONTRACTOR	DATE		
BENCH MARKS			
NO.	DATE		
SURVEY INFORMATION			
FIELD NOTES	BY		
ENGINEER'S SEAL			
90% REVIEW			
PRELIMINARY NOT FOR CONSTRUCTION 10.2021			
NO.	DATE	REVISIONS	BY
		RESPEC DESIGN	
DESIGNED BY: JWS	DATE: Oct 2021		
DRAWN BY: RESPEC	DATE: Oct 2021		
CHECKED BY: SEG	DATE: Oct 2021		

Current DRC
Project Number: _____

FIGURE 12

Date Submitted: October 15, 2021

INFRASTRUCTURE LIST

(Rev. 2-16-18)

EXHIBIT "A"

**TO SUBDIVISION IMPROVEMENTS AGREEMENT
DEVELOPMENT REVIEW BOARD (D.R.B.) REQUIRED INFRASTRUCTURE LIST**

Date Site Plan Approved: _____
Date Preliminary Plat Approved: _____
Date Preliminary Plat Expires: _____
DRB Project No.: _____
DRB Application No.: _____

**Volcano Mesa at The Trails
PROPOSED NAME OF PLAT AND/OR SITE DEVELOPMENT PLAN**

**Tract 2, Unit 2, The Trails
EXISTING LEGAL DESCRIPTION PRIOR TO PLATTING ACTION**

Following is a summary of PUBLIC/PRIVATE Infrastructure required to be constructed or financially guaranteed for the above development. This Listing is not necessarily a complete listing. During the SIA process and/or in the review of the construction drawings, if the DRC Chair determines that appurtenant items and/or unforeseen items have not been included in the infrastructure listing, the DRC Chair may include those items in the listing and related financial guarantee. Likewise, if the DRC Chair determines that appurtenant or non-essential items can be deleted from the listing, those items may be deleted as well as the related portions of the financial guarantees. All such revisions require approval by the DRC Chair, the User Department and agent/owner. If such approvals are obtained, these revisions to the listing will be incorporated administratively. In addition, any unforeseen items which arise during construction which are necessary to complete the project and which normally are the Subdivider's responsibility will be required as a condition of project acceptance and close out by the City.

Financially Guaranteed	Constructed Under	Size	Type of Improvement	Location	From	To	Construction Certification		
							Private Inspector	P.E.	City Cnst Engineer
DRC # []	DRC # []	PUBLIC ROADWAY IMPROVEMENTS							
[]	[]	32' F-F	RESIDENTIAL PAVING W/PCC CURB & GUTTER, PCC 5' WIDE SIDEWALK ON BOTH SIDES*	ATHERSTONE LANE	OAKRIDGE STREET	SIDREAUX LOOP (N)	/	/	/
[]	[]	28' F-F	RESIDENTIAL PAVING W/PCC CURB & GUTTER, PCC 5' WIDE SIDEWALK ON BOTH SIDES*	SIDREAUX LOOP	ATHERSTONE LANE (S)	ATHERSTONE LANE (N)	/	/	/
[]	[]	28'/32' F-F	RESIDENTIAL PAVING W/PCC CURB & GUTTER, PCC 5' WIDE SIDEWALK ON BOTH SIDES*	SIDREAUX LOOP	ATHERSTONE LANE (N)	CONNECTION W/RED STONE ROAD	/	/	/
[]	[]	8'	ASPHALT SIDEWALK PEDESTRIAN CONNECTION	TRACT G	SIDREAUX LOOP	PASEO DEL NORTE	/	/	/
		PUBLIC STORM DRAIN IMPROVEMENTS							
[]	[]	30" DIA.	RCP W/MH & INLETS	TRACT E	EAST SUBDIVISION BOUNDARY	ATHERSTONE LANE	/	/	/
[]	[]	30" DIA.	RCP W/MH & INLETS	ATHERSTONE LANE	TRACT E	SIDREAUX LOOP (N)	/	/	/
[]	[]	36" DIA.	RCP W/MH & INLETS	SIDREAUX LOOP	ATHERSTONE LANE	TRACT B	/	/	/
[]	[]	42" DIA.	RCP W/MH & INLETS	TRACT B	SIDREAUX LOOP	POND F5	/	/	/
		PUBLIC WATERLINE IMPROVEMENTS							
[]	[]	8" DIA.	WATERLINE W/VALVES AND HYDRANTS	OAK RIDGE STREET	RED STONE ROAD	EAST SUBDIVISION BOUNDARY	/	/	/

* SIDEWALKS TO BE BUILT/DEFERRED IN ACCORDANCE W/APPROVED SIDEWALK EXHIBIT

Financially Guaranteed DRC #	Constructed Under DRC #	Size	Type of Improvement	Location	From	To	Construction Certification		
							Private		City Cnst Engineer
							Inspector	P.E.	
<input type="text"/>	<input type="text"/>	8" DIA.	WATERLINE W/VALVES AND HYDRANTS	ATHERSTONE LANE	OAK RIDGE STREET	SIDREAU LOOP (N)	/	/	/
<input type="text"/>	<input type="text"/>	8" DIA.	WATERLINE W/VALVES AND HYDRANTS	SIDREAU LOOP	ATHERSTONE LANE (S)	RED STONE ROAD	/	/	/
<input type="text"/>	<input type="text"/>	8" DIA.	WATERLINE W/VALVES AND HYDRANTS	TRACT G	SIDREAU LOOP	WEST SUBDIVISION BOUNDARY	/	/	/
<input type="text"/>	<input type="text"/>	8" DIA.	WATERLINE W/VALVES AND HYDRANTS	SIDREAU COURT	SIDREAU LOOP	EAST SUBDIVISION BOUNDARY	/	/	/
<u>PUBLIC SANITARY SEWER IMPROVEMENTS</u>									
<input type="text"/>	<input type="text"/>	8" DIA.	SANITARY SEWER W/MH'S AND SERVICES	ATHERSTONE LANE	SIDREAU LOOP (S)	SIDREAU LOOP (N)	/	/	/
<input type="text"/>	<input type="text"/>	8" DIA.	SANITARY SEWER W/MH'S AND SERVICES	SIDREAU LOOP	ATHERSTONE LANE (S)	CONNECTION W/RED STONE ROAD	/	/	/
<input type="text"/>	<input type="text"/>	8" DIA.	SANITARY SEWER W/MH'S AND SERVICES	SIDREAU COURT	SIDREAU LOOP	EAST SUBDIVISION BOUNDARY	/	/	/
<input type="text"/>	<input type="text"/>	8" DIA.	SANITARY SEWER W/MH'S AND SERVICES	TRACT E	ATHERSTONE LANE	EAST PARCEL BOUNDARY	/	/	/
<u>PUBLIC STREETLIGHT IMPROVEMENTS</u>									
<input type="text"/>	<input type="text"/>		LED STREETLIGHTS, PULL BOXES, PNM CONNECTION, TRANSFORMER, AND WIRING	AS SHOWN ON STREETLIGHT EXHIBIT			/	/	/
<u>REMOVALS</u>									
<input type="text"/>	<input type="text"/>		EXISTING DRIVEWAY REMOVAL	TEMPORARY ACCESS	OAK RIDGE STREET	RED STONE ROAD	/	/	/
<input type="text"/>	<input type="text"/>						/	/	/
<input type="text"/>	<input type="text"/>						/	/	/
<input type="text"/>	<input type="text"/>						/	/	/
<input type="text"/>	<input type="text"/>						/	/	/
<input type="text"/>	<input type="text"/>						/	/	/

The items listed below are on the CCIP and approved for Impact Fee credits. Signatures from the Impact Fee Administrator and the City User Department is required prior to DRB approval of this listing. The Items listed below are subject to the standard SIA requirements.

Financially Guaranteed DRC #	Constructed Under DRC #	Size	Type of Improvement	Location	From	To	Construction Certification		
							Private Inspector	P.E.	City Cnst Engineer
<input type="text"/>	<input type="text"/>						/	/	/
<input type="text"/>	<input type="text"/>						/	/	/
Approval of Creditable Items:							Approval of Creditable Items:		
Impact Fee Administrator Signature Date							City User Dept. Signature Date		

NOTES

If the site is located in a floodplain, then the financial guarantee will not be released until the LOMR is approved by FEMA.
Street lights per City requirements.

- 1 _____

- 2 _____

- 3 _____

AGENT / OWNER	DEVELOPMENT REVIEW BOARD MEMBER APPROVALS
----------------------	--

Jeremy Shell
NAME (print)

RESPEC
FIRM



SIGNATURE - date

_____ DRB CHAIR - date

_____ TRANSPORTATION DEVELOPMENT - date

_____ UTILITY DEVELOPMENT - date

_____ CITY ENGINEER - date

_____ PARKS & RECREATION - date

_____ AMAFCA - date

_____ CODE ENFORCEMENT - date

_____ - date

DESIGN REVIEW COMMITTEE REVISIONS
--

REVISION	DATE	DRC CHAIR	USER DEPARTMENT	AGENT /OWNER

Current DRC
Project Number: _____

FIGURE 12

Date Submitted: September 23, 2021

INFRASTRUCTURE LIST

(Rev. 2-16-18)

EXHIBIT "A"

**TO SUBDIVISION IMPROVEMENTS AGREEMENT
DEVELOPMENT REVIEW BOARD (D.R.B.) REQUIRED INFRASTRUCTURE LIST**

Date Site Plan Approved: _____
Date Preliminary Plat Approved: _____
Date Preliminary Plat Expires: _____
DRB Project No.: _____
DRB Application No.: _____

Volcano Mesa at The Trails

PROPOSED NAME OF PLAT AND/OR SITE DEVELOPMENT PLAN

Tract 2, Unit 2, The Trails

EXISTING LEGAL DESCRIPTION PRIOR TO PLATTING ACTION

Following is a summary of PUBLIC/PRIVATE Infrastructure required to be constructed or financially guaranteed for the above development. This Listing is not necessarily a complete listing. During the SIA process and/or in the review of the construction drawings, if the DRC Chair determines that appurtenant items and/or unforeseen items have not been included in the infrastructure listing, the DRC Chair may include those items in the listing and related financial guarantee. Likewise, if the DRC Chair determines that appurtenant or non-essential items can be deleted from the listing, those items may be deleted as well as the related portions of the financial guarantees. All such revisions require approval by the DRC Chair, the User Department and agent/owner. If such approvals are obtained, these revisions to the listing will be incorporated administratively. In addition, any unforeseen items which arise during construction which are necessary to complete the project and which normally are the Subdivider's responsibility will be required as a condition of project acceptance and close out by the City.

Financially Guaranteed DRC #	Constructed Under DRC #	Size	Type of Improvement	Location	From	To	Construction Certification		
							Private		City Cnst Engineer
							Inspector	P.E.	
<input type="text"/>	<input type="text"/>	35' F-F*	ARTERIAL PAVING FOR ADDITIONAL 23' EASTBOUND LANES, PCC CURB & GUTTER, 8' BIKE LANE W/4' BUFFER, 10' ASPHALT TRAIL ON SOUTH SIDE	PASEO DEL NORTE	WEST SUBDIVISION BOUNDARY	EAST SUBDIVISION BOUNDARY	/	/	/
<input type="text"/>	<input type="text"/>						/	/	/
<input type="text"/>	<input type="text"/>						/	/	/
<input type="text"/>	<input type="text"/>						/	/	/
<input type="text"/>	<input type="text"/>						/	/	/
<input type="text"/>	<input type="text"/>						/	/	/
<input type="text"/>	<input type="text"/>						/	/	/
<input type="text"/>	<input type="text"/>						/	/	/
<input type="text"/>	<input type="text"/>						/	/	/
<input type="text"/>	<input type="text"/>						/	/	/

* PROCEDURE C AGREEMENT

The items listed below are on the CCIP and approved for Impact Fee credits. Signatures from the Impact Fee Administrator and the City User Department is required prior to DRB approval of this listing. The Items listed below are subject to the standard SIA requirements.

Financially Guaranteed DRC #	Constructed Under DRC #	Size	Type of Improvement	Location	From	To	Construction Certification		
							Private Inspector	P.E.	City Cnst Engineer
<input type="text"/>	<input type="text"/>						/	/	/
<input type="text"/>	<input type="text"/>						/	/	/
Approval of Creditable Items:							Approval of Creditable Items:		
Impact Fee Administrator Signature Date							City User Dept. Signature Date		

NOTES

If the site is located in a floodplain, then the financial guarantee will not be released until the LOMR is approved by FEMA.
Street lights per City requirements.

1 _____

2 _____

3 _____

AGENT / OWNER

DEVELOPMENT REVIEW BOARD MEMBER APPROVALS

Jeremy Shell
NAME (print)

RESPEC
FIRM

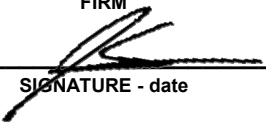

SIGNATURE - date

_____ DRB CHAIR - date

_____ TRANSPORTATION DEVELOPMENT - date

_____ UTILITY DEVELOPMENT - date

_____ CITY ENGINEER - date

_____ PARKS & RECREATION - date

_____ AMAFCA - date

_____ CODE ENFORCEMENT - date

_____ - date

DESIGN REVIEW COMMITTEE REVISIONS

REVISION	DATE	DRC CHAIR	USER DEPARTMENT	AGENT /OWNER