

LOCATION MAP
NOT TO SCALE

SUBDIVISION DATA:

1. Zone Atlas Index Nos.: R13, R14, S13, S14 and T14.
2. Gross Subdivision Acreage: 200.8912 Acres.
3. Total Number of Tracts Created: 2 Tracts.
4. Date of Survey: 01-11-2023.
5. Plat is located within Section(s) 20, 29, 30, 31 & 32 T 9 N, R 3 E; N.M.P.M.
6. **NO** public streets were created.
7. Zoning: PC.

PURPOSE OF PLAT:

The purpose of this Plat is to subdivide Tract 6 of BULK LAND PLAT TRACTS 1 - 15, MESA DEL SOL, as the same is shown and designated on the plat thereof, filed June, 21, 2006 in Book 2006C, Page 195 as Document No. 2006091342, into two (2) Tracts as shown herein.

PUBLIC UTILITY EASEMENTS:

shown on this plat are granted for the common and joint use of:

- A. Public Service Company of New Mexico ("PNM"), a New Mexico corporation, (PNM Electric) for installation, maintenance, and service of overhead and underground electrical lines, transformers, and other equipment and related facilities reasonably necessary to provide electrical services.
- B. New Mexico Gas Company for installation, maintenance, and service of natural gas lines, valves and other equipment and facilities reasonably necessary to provide natural gas.
- C. Qwest Corporation d/b/a CenturyLink QC for the installation, maintenance, and service of such lines, cable, and other related equipment and facilities reasonably necessary to provide communication services.
- D. Comcast related equipment and facilities reasonably necessary to provide Comcast Cable services.

Included, is the right to build, rebuild, construct, reconstruct, locate, relocate, change, remove, replace, modify, renew, operate and maintain facilities for purposes described above, together with free access to, from, and over said easements, with the right and privilege of going upon, over and across adjoining lands of Grantor for the purposes set forth herein and with the right to utilize the right of way and easement to extend services to customers of Grantee, including sufficient working area space for electric transformers, with the right and privilege to trim and remove trees, shrubs or bushes which interfere with the purposes set forth herein. No building, sign, pool (above ground or subsurface), hot tub, concrete or wood pool decking, or other structure shall be erected or constructed on said easements, nor shall any well be drilled or operated thereon. Property owners shall be solely responsible for correcting any violations of National Electrical Safety Code by construction of pools, decking, or any structures adjacent to or near easements shown on this plat.

Easements for electric transformer/switchgears, as installed, shall extend ten (10) feet in front of transformer/switchgear doors and five (5) feet on each side.

Disclaimer

In approving this plat, Public Service Company of New Mexico (PNM), New Mexico Gas Company (NMGC) and Qwest Corporation D/B/A CenturyLink (QWEST), Comcast did not conduct a Title Search of the properties shown hereon. Consequently, PNM, NMGC, Qwest and COMCAST do not waive or release any easement or easement rights which may have been granted by prior plat, replat or other document and which are not shown on this plat.

LANDFILL DISCLOSURE STATEMENT:

The subject property is located near or is a former landfill site. Due to the subject property being on or near a former landfill, certain precautionary measures may need to be taken to ensure the health and safety of the public. Recommendations made by a professional engineer with expertise in landfills and landfill gas issues (as required by the most current version of the "Interim Guidelines for Development within 1000 feet of Landfills") shall be consulted prior to development of the site.

LEGAL DESCRIPTION:

Tract 6 of BULK LAND PLAT TRACTS 1 - 15, MESA DEL SOL, SECTIONS 13-15, 20-24, 29-29, 32-35, TOWNSHIP 9 NORTH, RANGE 3 EAST, N.M.P.M., ALBUQUERQUE, BERNALILLO COUNTY, NEW MEXICO filed in the Office of Bernalillo County on June, 21, 2006 in Book 2006C, Page 195 as Document No. 2006091342.

ABCWUA NOTE: Public water and public sanitary sewer infrastructure is currently unavailable for the subject site and any future service will require the extension of public water and public sanitary sewer infrastructure. Tract 6B is determined to be for the use of a PNM sub-station and is not seeking service.

DOCH 2023027477

05/05/2023 09:17 AM Page: 1 of 2
PLAT: R 325, 00 B, 2023C P: 0032 Linda Stover, Bernalillo County

FREE CONSENT AND DEDICATION:

The plat shown hereon is made with the owner (s) free consent and in accordance of the desires of the undersigned owner (s), the execution of this plat is their free act and deed. Those signing as owner (s) warrant that they hold among them, complete indefeasible title in fee simple to the land shown on this plat. Owner(s) hereby affirm that the described property shown on this plat lies within the platting and subdivision jurisdiction of City of Albuquerque, New Mexico. Said owner(s) hereby grant all Easements as shown on this plat.

By: [Signature]
Steve B. Chavez
MDS INVESTMENTS, LLC a New Mexico limited liability company

State of New Mexico)

County of Bernalillo)

This instrument was acknowledged before me on 4th day of April, 2023

by Steve B. Chavez, MDS INVESTMENTS, LLC

My Commission Expires: August 30, 2026 [Signature]
Notary Public

STATE OF NEW MEXICO
NOTARY PUBLIC
Kimberly Diane Legan
Commission No. 1138659
August 30, 2026

JURISDICTIONAL AFFIDAVIT:

I Barry S. Phillips, a registered Professional New Mexico Surveyor, hereby affirm that the property described does lie within the platting and subdivision jurisdiction of the City of Albuquerque.

[Signature]
Barry S. Phillips
New Mexico Professional Surveyor 15517

NOTES

1. Tract is subject to Flood Zone X, Zone A as designated on FIRM Maps 35001C0531H effective date 8/16/2012, 35001C0533H effective date 8/16/2012 35001C535G effective 9/28/2008 AND 35061C0075E effective 8/19/2010.
2. Basis of Bearings is the inverse between City of Albuquerque Control Stations "4_S14" having NM NAD 83 State Plane Grid Coordinates Central Zone: N=1,448,587.42 and E= 1,518,781.94 and "6_R14" having NM NAD 83 State Plane Grid Coordinates Central Zone: N=1,452,796.466 and E=1,520,323.699. Bearing=N 20° 07' 03" E.
3. Distances are ground distances "US SURVEY FOOT".
4. Record Bearings and distances are the same as shown on plats referenced hereon.
5. Pursuant to Section 14-14-4-7 of the City of Albuquerque Code of Ordinances, "no property within the area of this Plat shall at any time be subject to a deed restriction, covenant, or binding agreement prohibiting solar collectors from being installed on buildings or erected on the lots of parcels within the area of proposed Plat. The foregoing requirement shall be a condition to approval of this plat".
6. All corners created with this plat will be monumented with a #5 rebar and plastic survey cap stamped "PHILLIPS PS 15517" or nail and washer stamped "PHILLIPS PS 15517".

SURVEYOR'S CERTIFICATION:

I, BARRY S. PHILLIPS a Registered Professional New Mexico Surveyor, certify that I am responsible for this survey and that this plat was prepared by me or under my supervision, shows all existing easements as shown on the plats of record, or made known to me by the owner, utility companies, or other interested parties and conforms to the Minimum Requirements of the Board of Registration for Professional Engineers and Professional Surveyors and is true and accurate to the best of my knowledge and belief.

[Signature] 3-31-2023
BARRY S. PHILLIPS Date:
New Mexico Professional Surveyor 15517



PLAT OF
TRACTS 6A and 6B
BEING A REPLAT OF TRACT 6 OF BULK LAND PLAT
TRACTS 1 - 15, MESA DEL SOL
SECTIONS 20, 29, 30, 31 and 32
TOWNSHIP 9 NORTH, RANGE 3 EAST N.M.P.M.
CITY OF ALBUQUERQUE
BERNALILLO COUNTY, NEW MEXICO
MARCH 2023

Project Number: PR-2023-008364
Application Number: SD-2023-00084

PLAT APPROVAL

Utility Approvals:

<u>[Signature]</u> PNM Electric Services	03/31/2023 Date
<u>[Signature]</u> New Mexico Gas Company	3/31/2023 Date
<u>[Signature]</u> CenturyLink	04/03/2023 Date
<u>[Signature]</u> Comcast	04/03/2023 Date

City Approvals:

<u>[Signature]</u> City Surveyor	4/4/2023 Date
N/A	05/04/2023 Date
*Real Property Division (conditional)	05/04/2023 Date
**Environmental Health Department (conditional)	May 1, 2023 Date
<u>[Signature]</u> Traffic Engineering, Transportation Division	May 4, 2023 Date
<u>[Signature]</u> Parks and Recreation Department	May 2, 2023 Date
<u>[Signature]</u> AMATCA	4/3/2023 Date
<u>[Signature]</u> Hydrology	May 1, 2023 Date
<u>[Signature]</u> Code Enforcement	May 1, 2023 Date
<u>[Signature]</u> Planning Department	May 1, 2023 Date
<u>[Signature]</u> City Engineer	May 4, 2023 Date
N/A	05/04/2023 Date
***MRGCD (conditional)	Date

TAX CERTIFICATION

This is to certify that taxes are current and paid on UPC #

Tract 6 Bulk Land Plat of Mesa Del Sol Tracts 1-15 UPC# 101405008941520101

Property Owner of Record: MDS INVESTMENTS LLC

[Signature] 5/4/23
Bernalillo County Treasurer's Office Date

Bohannon & Huston
www.bhinc.com 800.877.5332

**PLAT OF
TRACTS 6A and 6B
BEING A REPLAT OF TRACT 6 OF BULK LAND PLAT
TRACTS 1 - 15, MESA DEL SOL
SECTIONS 20, 29, 30, 31 and 32
TOWNSHIP 9 NORTH, RANGE 3 EAST N.M.P.M.
CITY OF ALBUQUERQUE
BERNALILLO COUNTY, NEW MEXICO
MARCH 2023**



500 250 0 500
1"=500'

DOC# 2023027477
05/05/2023 09:17 AM Page: 2 of 2
PLAT# R \$25.00 B: 2023C P: 0032 Linda Stover, Bernalillo County

LEGEND

- FOUND PLASTIC CAP STAMPED AS NOTED
- T FOUND T-RAIL
- △ FOUND BRASS CAP AS NOTED
- ⊠ FOUND WASHER IN CONCRETE
- SET #5 REBAR AND ORANGE PLASTIC SURVEY CAP STAMPED "PHILLIPS PS 15517" OR NAIL AND WASHER STAMPED "PHILLIPS PS 15517" UNLESS OTHERWISE NOTED
- SUBJECT PROPERTY LINE
- ADJOINING PROPERTY LINE
- - - EXISTING EASEMENT LINE
- - - EXISTING RIGHT-OF-WAY LINE

ALBUQUERQUE GEODETIC REFERENCE STATION 4_S14
GEOGRAPHIC POSITION (NAD 1983)
NM STATE PLANE GRID COORDINATES
(CENTRAL ZONE, US SURVEY FOOT)
N=1448367.421 USF E=1518781.94 USF
GROUND TO GRID FACTOR = 0.999679836
Δα = -00°13'58.09"
NAVD 1988 ELEVATION = 5038.98 USF

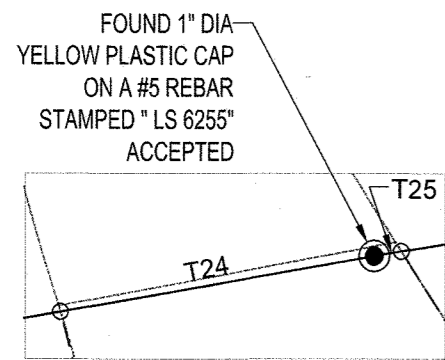

DETAIL "A"
NOT TO SCALE

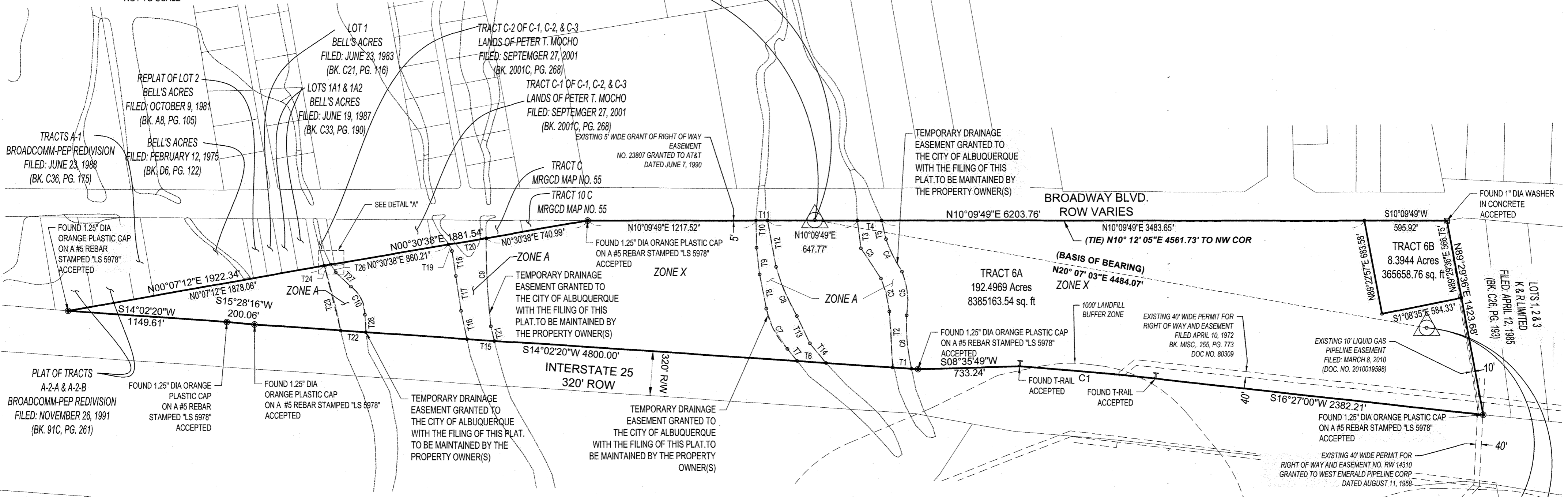

TRACT CURVE DATA

ID	DELTA	RADIUS	ARC	TANGENT	CHORD BRG	CHORD
C1	02°25'55" LT	23158.32'	983.00'	491.57'	S15°14'07"W	982.93'

PROPOSED EASEMENT CURVE DATA

ID	ARC	RADIUS	TANGENT	DELTA	CHORD	CHORD BRG
C2	244.69'	1021.74'	122.93'	13°43'16"	244.10'	S85°51'25"W
C3	262.28'	11195.75'	131.14'	1°20'32"	262.27'	S66°36'04"W
C4	261.04'	1073.05'	131.17'	13°56'19"	260.40'	N73°54'56"E
C5	320.75'	587.24'	164.49'	31°17'42"	316.78'	S85°56'57"E
C6	387.88'	1398.94'	195.19'	15°53'10"	386.64'	S85°09'37"E
C7	331.59'	579.74'	170.47'	32°46'17"	327.09'	S72°26'38"W
C8	386.10'	1667.65'	193.92'	13°15'56"	385.24'	N77°10'21"E
C9	635.28'	5499.36'	317.99'	6°37'07"	634.92'	S82°54'34"E
C10	235.11'	247.28'	127.29'	54°28'28"	226.35'	S73°32'18"W

PROPOSED EASEMENT TANGENT DATA

ID	BEARING	DISTANCE
T1	S14°02'20"W	136.64'
T2	N83°16'13"W	404.41'
T3	N87°10'05"W	201.87'
T4	N10°09'49"E	175.03'
T5	N86°52'08"E	138.43'
T6	S14°02'20"W	209.33'
T7	S61°22'03"W	111.80'
T8	S88°55'01"W	251.38'
T9	N86°26'56"W	193.81'
T10	N81°03'17"W	196.57'

PROPOSED EASEMENT TANGENT DATA

ID	BEARING	DISTANCE
T11	N10°09'49"E	83.87'
T12	N89°46'57"E	339.44'
T13	N74°28'46"E	217.76'
T14	N60°41'13"E	183.54'
T15	S14°02'20"W	198.20'
T16	S88°17'18"W	208.81'
T17	N88°23'32"W	253.52'
T18	N88°43'48"W	179.06'
T19	S71°42'10"W	54.19'
T20	N00°30'38"E	276.50'

PROPOSED EASEMENT TANGENT DATA

ID	BEARING	DISTANCE
T21	N86°40'24"E	108.93'
T22	S14°02'20"W	181.80'
T23	S85°47'44"W	480.94'
T24	N00°07'12"E	44.28'
T25	N00°30'38"E	3.84'
T26	N67°32'29"E	67.23'
T27	N53°10'38"E	148.55'
T28	S83°01'57"E	126.45'

ALBUQUERQUE GEODETIC REFERENCE STATION 6_R14
GEOGRAPHIC POSITION (NAD 1983)
NM STATE PLANE GRID COORDINATES
(CENTRAL ZONE, US SURVEY FOOT)
N=1452796.466 USF E=1520323.699 USF
GROUND TO GRID FACTOR = 0.999672306
Δα = -00°13'47.83"
NAVD 1988 ELEVATION = USF

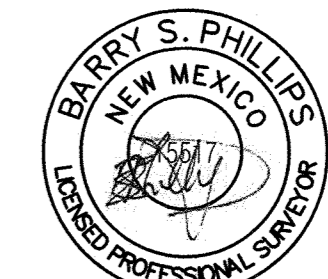

Bohannon & Huston
www.bhinc.com 800.877.5332