

WOODLAND AVE NW

2ND STREET NW

MENAUL BLVD NW

**PLANT SCHEDULE**

SYMBOL	QTY	BOTANICAL / COMMON NAME	INSTALL SIZE	MATURE SIZE	WATER USE
<b>TREES</b>					
	6	Cercis canadensis 'Pink Pom Poms' / Pink Pom Poms Eastern Redbud	2.5' cal.	20' ht. x 20' spd.	Medium
	6	Chilopsis linearis / Desert Willow	2.5' cal.	20' ht. x 20' spd.	Medium
	6	Pistacia chinensis / Chinese Pistache	2.5' cal.	30' ht. x 30' spd.	Medium
<b>SHRUBS</b>					
	9	Buddleja davidii nanhoensis / Dwarf Butterfly Bush	5 gal.	5' ht. x 8' spd.	Medium
	20	Caryopteris x clandonensis / Blue Mist Spirea	5 gal.	3' ht. x 3' spd.	Low+
	6	Cotoneaster buxifolius/ glaucophyllus / Grey- Leaf Cotoneaster	5 gal.	8' ht. x 10' spd.	Medium
	10	Elaeagnus Pungens / Silverberry	5 gal.	10' x 10'	Medium
	8	Hesperaloe parviflora / Red Yucca	5 gal.	3' ht. x 3' spd.	Low+
	7	Hibiscus syriacus / Rose of Sharon	5 gal.	10' x 10'	Medium
	8	Nolina macrocarpa / Beargrass	5 gal.	5' ht. x 5' spd.	RW
	25	Panicum virgatum / Switchgrass	5 gal.	4' ht. X 4' spd.	Medium
	10	Rhus Aomatic / Gro-Low Sumac	5 gal.	2' ht. x 6' spd.	Low+
	12	Rosa "Pink Double Knock Out" / Pink Double Knock Out Rose	5 gal.	4' ht. X 4' spd.	Medium

**LANDSCAPE CALCULATIONS**

ZONING	APPLICABLE REGULATION(S)	VALUE	REQUIREMENT	PROVIDED
ZONING	IDO 14-16-5-6 AND PART 6-6-2 OF ROA 1994			
TOTAL LOT AREA (ACRES)	0.93	GROUNDCOVER (% - REQ)	25.0%	
TOTAL LOT AREA (SF)	40557	GROUNDCOVER (SF - REQ)	3147	
BUILDING AREA (SF)	3315	GROUNDCOVER (SF - PROV.)	3200	
NET LOT AREA (SF)	37,242			
REQUIRED LANDSCAPE (%)	15.0%	PARKING LOT AREA (SF)	14268	
REQUIRED LANDSCAPE (SF)	5586	REQ. PARKING LANDSCAPE 10% (SF)	1427	
LANDSCAPE PROVIDED (SF)	16785	PROV. PARKING LANDSCAPE (SF)	7346	
		REQ. PARKING TREES (1/10 SPOTS)	2	
		PROV. PARKING TREES	3	
VEGETATIVE COVER (% - REQ)	75.0%			
VEGETATIVE COVER (SF - REQ)	12589			
VEGETATIVE COVER (SF - PROV.)	20500			

**STREET TREE CALCULATIONS**

STREET TREE ORDINANCE REQUIRES SPACING OF STREET TREE AT 25' O.C.

WOODLAND BLVD NW, 109 FT  
 REQUIRED NUMBER OF TREES 4  
 PROVIDED NUMBER OF TREES 4

2ND STREET NW, 280 FT  
 REQUIRED NUMBER OF TREES 11  
 PROVIDED NUMBER OF TREES 11

MENAUL BLVD NW, 96 FT  
 REQUIRED NUMBER OF TREES 4  
 PROVIDED NUMBER OF TREES 4

**PLANTING NOTES**

ALL PLANTS TO CONTAIN BARK MULCH AROUND THE ROOTBALL, TO THE EXTENT TO COVER THE DRIP LINES.

**GENERAL NOTES**

IT IS THE INTENT OF THIS PLAN TO COMPLY WITH APPLICABLE CITY WATER CONSERVATION LANDSCAPING AND WATER WASTE ORDINANCE PLANTING RESTRICTION APPROACH. APPROVAL OF THIS PLAN DOES NOT CONSTITUTE OR IMPLY EXEMPTION FROM WATER WASTE PROVISIONS OF THE WATER CONSERVATION LANDSCAPING AND WATER WASTE ORDINANCE.

LANDSCAPE MAINTENANCE SHALL BE THE RESPONSIBILITY OF THE PROPERTY OWNER. THE PROPERTY OWNER SHALL MAINTAIN STREET TREES IN A LIVING, HEALTHY, AND ATTRACTIVE CONDITION.

APPROVAL OF THIS PLAN DOES NOT CONSTITUTE OR IMPLY EXEMPTION FROM WATER WASTE PROVISIONS OF THE WATER CONSERVATION LANDSCAPING AND WATER WASTE ORDINANCE. WATER MANAGEMENT IS THE SOLE RESPONSIBILITY OF THE PROPERTY OWNER.

ALL LANDSCAPING WILL BE IN CONFORMANCE WITH THE CITY OF ALBUQUERQUE ZONING CODES, LAND-USE ORDINANCES, AND WATER CONSERVATION LANDSCAPING AND WATER WASTE ORDINANCE. IN GENERAL, WATER CONSERVATIVE, ENVIRONMENTALLY SOUND LANDSCAPE PRINCIPLES WILL BE FOLLOWED IN DESIGN AND INSTALLATION.

GRAY GRAVEL OVER FILTER FABRIC TO A MINIMUM DEPTH OF 3" SHALL BE PLACED IN ALL LANDSCAPE AREAS WHICH ARE NOT DESIGNATED TO RECEIVE NATIVE SEED OR OTHER HATCHED GROUNDCOVER AREA. ALL GRAVEL SHALL BE PLACED .5"-1" LOWER THAN ADJACENT HARD SURFACES.

PRIOR TO CONSTRUCTION, LANDSCAPE CONTRACTOR SHALL VERIFY LOCATION OF ALL UTILITY LINES. IN CASE OF A DISCREPANCY BETWEEN UTILITIES INDICATED ON PLAN AND ACTUAL FIELD VERIFICATION, CONTRACTOR SHALL CEASE WORK AND NOTIFY LANDSCAPE ARCHITECT IMMEDIATELY FOR DIRECTIONS ON HOW TO PROCEED.

POSITIVE DRAINAGE AWAY FROM ALL STRUCTURES IS TO REMAIN AFTER ALL LANDSCAPE WORK IS COMPLETED.

\*NOTE- ALL GROUND COVER AND MULCH AREAS TO COMPLY WITH IDO SECTIONS 14-16-5-6(C)(5)(c) & 14-16-5-6(C)(5)(e)

**IRRIGATION NOTES:**

IRRIGATION SYSTEM MAINTENANCE AND OPERATION SHALL BE THE SOLE RESPONSIBILITY OF THE OWNER. IT SHALL BE THE OWNERS RESPONSIBILITY TO ENSURE THAT FUGITIVE WATER DOES NOT LEAVE THE SITE DUE TO OVERWATERING OR MALFUNCTIONING EQUIPMENT.

ALL ON-SITE PLANT MATERIAL, NEW AND EXISTING, SHALL BE IRRIGATED BY COMPLETE, AUTOMATIC DRIP IRRIGATION WITH SUBTERRANEAN LATERALS. TREES SHALL RECEIVE ONE (1) NETAFIM SPIRAL (50' LENGTH) WITH 3 LOOPS AT A FINAL RADIUS OF 4.5' FROM TREE TRUNK, PINNED IN PLACE. NETAFIM SHALL HAVE EMITTERS 12" O.C. WITH A FLOW OF .6 GPH. SHRUBS TO RECEIVE (2) 1.0 GPH DRIP EMITTERS. DRIP AND BUBBLER SYSTEMS TO BE TIED TO 1/2" POLYPIPE WITH FLUSH CAPS AT EACH END.

RUN TIME PER EACH SHRUB DRIP VALVE WILL BE APPROXIMATELY 15 MINUTES PER DAY. TREE DRIP VALVE SHALL RUN 1.5 HOURS, 3 TIMES PER WEEK. RUN TIME WILL BE ADJUSTED ACCORDING TO THE SEASON.

POINT OF CONNECTION FOR IRRIGATION SYSTEM IS UNKNOWN AT CURRENT TIME AND WILL BE COORDINATED IN THE FIELD. IRRIGATION WILL BE OPERATED BY AUTOMATIC CONTROLLER.

LOCATION OF CONTROLLER TO BE FIELD DETERMINED AND POWER SOURCE FOR CONTROLLER TO BE PROVIDED BY OTHERS.

IRRIGATION MAINTENANCE SHALL BE THE RESPONSIBILITY OF THE PROPERTY OWNER.

WATER AND POWER SOURCE SHALL BE THE RESPONSIBILITY OF THE DEVELOPER/BUILDER.

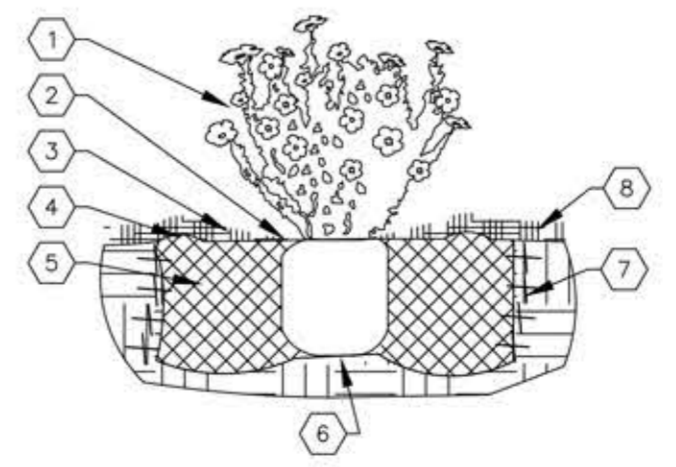

**SHRUB PLANTING KEYED NOTES**

1. SHRUB LOCATION, SPECIES, AND CONDITION AS PER PLAN.
2. INSTALL WITH TOP OF ROOT BALL FLUSH WITH SUBGRADE (BOTTOM OF MULCH)
3. USE WOOD CHIP MULCH OVER ROOTBALL, FEATHERED TO A 2" DEPTH AND HELD BACK 2" FROM TRUNKS AND STEMS AND TO COVER DRIPLINE.
4. 2" HIGH X 8" WIDE BERM
5. BACKFILL PER SPECIFICATIONS. LIGHTLY TAMP IN LIFTS AND WATER-IN TO ELIMINATE VOIDS AND AIR POCKETS
6. UNDISTURBED NATIVE SOIL
7. SCARIFY AND LOOSEN EDGES OF PLANTING PIT.
8. MULCH - SEE PLANTING PLAN. 3" DEPTH UNLESS OTHERWISE NOTED.

01 SHRUB PLANTING  
 NTS

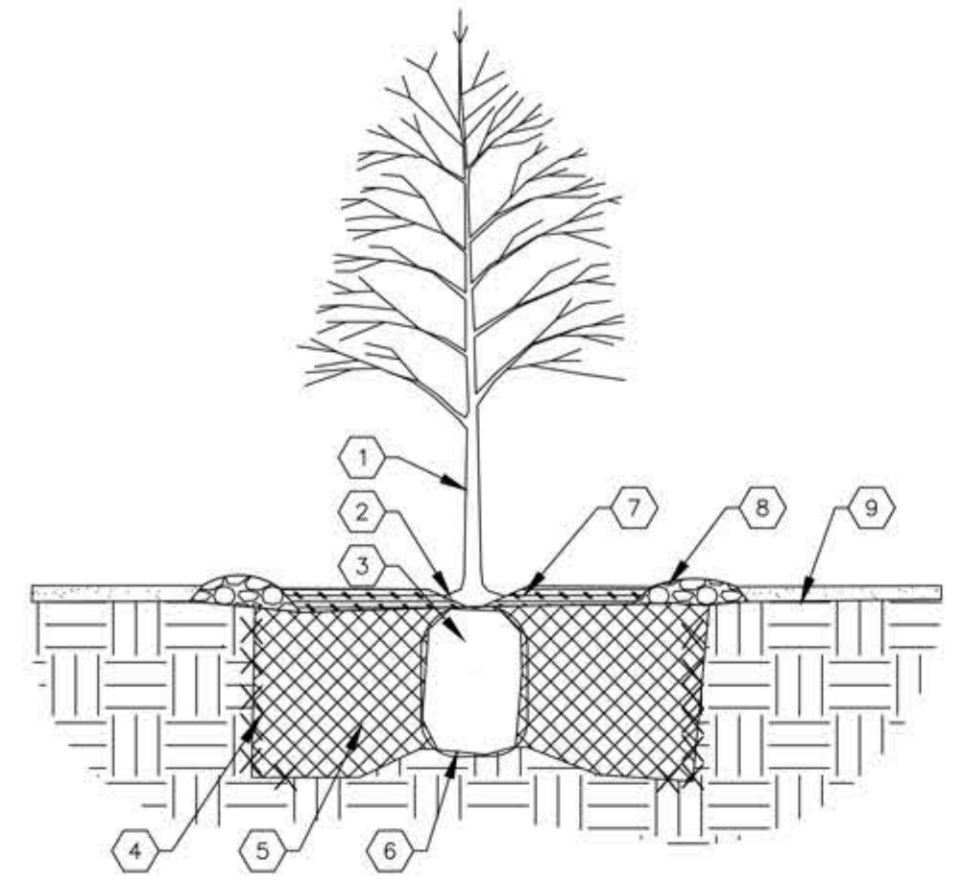

**TREE PLANTING KEYED NOTES**

1. TREE LOCATION, SPECIES, AND CONDITION AS PER PLAN.
2. REMOVING EXISTING SOIL (FROM NURSERY) AS NEEDED TO EXPOSE ROOT FLARE. INSTALL WITH ROOT FLARE FLUSH WITH SUBGRADE (BOTTOM OF MULCH)
3. INSTALL TREE PLUMB. REMOVE WIRE BASKET, WOOD BOX, PLASTIC, TWINE, AND/OR ROPE PRIOR TO BACKFILL. REMOVE BURLAP EXCEPT FROM BOTTOM OF ROOT BALL.
4. SCARIFY AND LOOSEN EDGES OF PLANTING PIT.
5. BACKFILL PER SPECIFICATIONS. LIGHTLY TAMP IN LIFTS AND WATER-IN TO ELIMINATE VOIDS AND AIR POCKETS.
6. UNDISTURBED NATIVE SOIL UNDER ROOTBALL TO PREVENT SETTLING.
7. INSTALL WOOD CHIP ORGANIC MULCH OVER ROOTBALL AND TO COVER DRIP LINE. GENERALLY, MULCH SHOULD BE HELD 4" BACK FROM TREE TRUNK.
8. 4" HIGH X 16" WIDE COBBLE BERM AT DRIP LINE.
9. MULCH - SEE PLANTING PLAN

02 TREE PLANTING  
 NTS

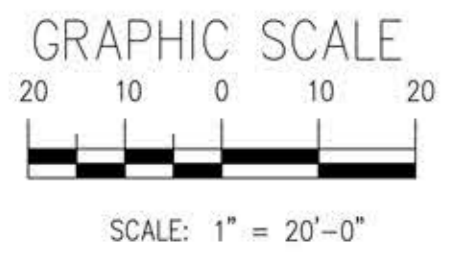

SCALE: 1" = 20'-0"

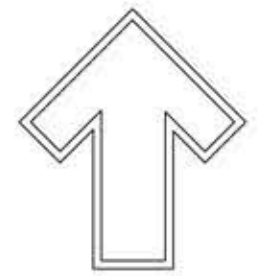

The Hilltop  
 7909 Edith N.E.  
 Albuquerque, NM 87113  
 Cont. Lic. #26458  
 Ph. (505) 898-9690  
 Fax (505) 898-7137  
 ted@hilltoplandscaping.com



MAY 9, 2024

Tidal Wave Auto Spa  
 2nd Street & Menaul  
 Albuquerque, NM

Preliminary Landscape Design

The design contained herein remains the property of The Hilltop Landscape Architects and Contractors and are protected by copyright laws. This is an original design and must not be released or used for any other project without the prior written consent of the designer.



DRAWN BY: th  
 CHECKED BY: CS  
 DATE: 07/07/2024

SHEET #

LS-101