

Albuquerque Control Survey Monument "16-118"  
 Zone (NAD83) as published:  
 Year: 1983, 1987, 2002  
 Ground to grid factor: 0.99961045  
 Data Alpha: -071129  
 Elevation: 5283.415 (NAVD83)

- LEGEND**
- WALL
  - SANITARY SEWER MANHOLE
  - DRAIN INLET
  - TELEPHONE PEDESTAL
  - GROUND LIGHT PEDESTAL
  - CITY PEDESTAL
  - SIDEWALK DRAIN COVER
  - LIGHT POLE
  - WATER METER
  - ROOF DRAIN
  - HANDICAP PARKING SPACE
  - SPOT ELEVATION

- KEYED NOTE:**
- ① INDICATES PROPOSED AREA OF ADDITION
  - ② EXISTING LIGHT POLE LOCATION TO REMAIN
  - ③ CONC. SIDEWALK RE: DET 13/A1.1 RE: SITE PLAN FOR JOINT LAYOUT
  - ④ INDICATES EXISTING CAR PARKING CANOPY TO REMAIN
  - ⑤ INDICATES PROPOSED CAR PARKING CANOPY ADDITION TO MATCH EXISTING CANOPY
  - ⑥ EXISTING 14' UTILITY EASEMENT PER PLAT FILED MAY 18, 1981 PLAT BOOK C18, FOLIO 81 TO BE VACATED
  - ⑦ EXISTING LOT LINE TO BE VACATED
  - ⑧ SIDEWALK FLUME RE: 3/A1.1 FOR DET INFO
  - ⑨ SIDEWALK/CURB DETAIL RE: 8/A1.1 FOR DET INFO
  - ⑩ CROSSWALK PAINT DESIGNATION RE: 12/A1.1 FOR DET INFO
  - ⑪ BIKE RACK LOCATION RE: 1/A1.1 FOR DET INFO
  - ⑫ MOTORCYCLE SIGNAGE RE: 9A/A1.1 FOR DET INFO
  - ⑬ CONC. PEDESTRIAN END ISLAND RAMP RE: 8/A1.2 FOR DET INFO
  - ⑭ CONC. PEDESTRIAN TAPERED RAMP RE: 6A/A1.1 FOR DET INFO
  - ⑮ PAINTED SIGNING AS INDICATED WITHIN SITE PLAN- MIN 16" HIGH LETTERING
  - ⑯ REFUSE ENCLOSURE RE: 1 THRU 7 /A1.2 FOR DET INFO
  - ⑰ WHEEL STOP RE: 10 /A1.1 FOR DET INFO
  - ⑱ BANCH LOCATION RE: 4/A1.1 FOR DET INFO

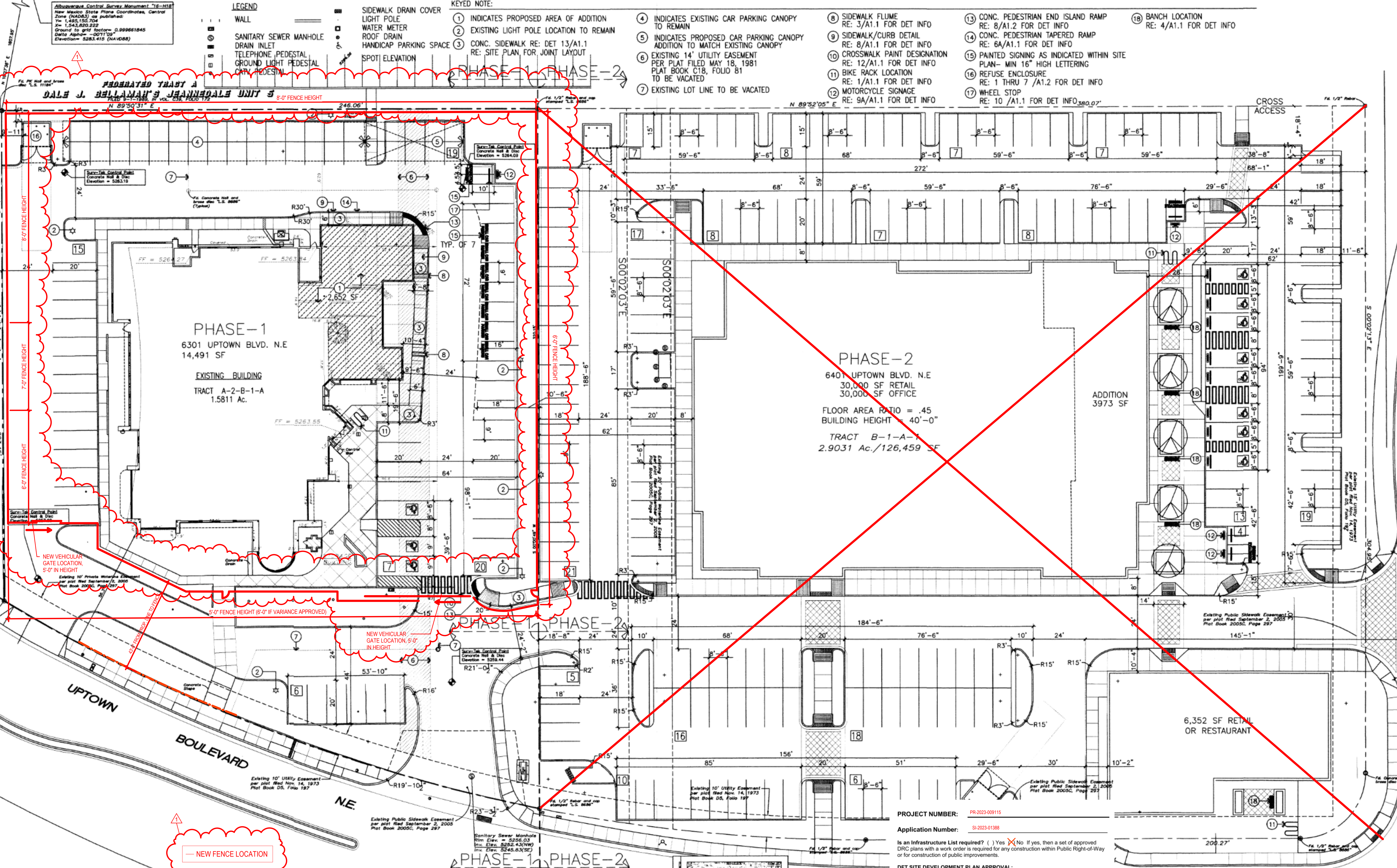

NEW FENCE LOCATION

SITE DATA TABLE	PHASE-1	PHASE-2
LEGAL DESCRIPTION	TRACT A-2-B-1-A	TRACT B-1-A-1
TOTAL ACREAGE	1.5811 Acres	2.9031 Acres
EXISTING ZONING		
BUILDING SIZE	RE: SITE	RE: SITE
FAR	EXISTING FAR= 21%	EXISTING FAR= 45%
EXISTING USES	OFFICE	OFFICE/RETAIL
TOTAL PARKING PROVIDED	67 SPACES	177 SPACES
TOTAL PARKING REQ.	67 SPACES	177 SPACES
H.C. REQ.	3 H.C. (INCLUDING 2 VAN ACCESSIBLE)	8 H.C. (INCLUDING 4 VAN ACCESSIBLE)
H.C. PROVIDED	11 H.C. (INCLUDING 6 VAN ACCESSIBLE)	11 H.C. (INCLUDING 6 VAN ACCESSIBLE)
BIKE SPACES PROVIDED	5 BIKE SPACES	10 BIKE SPACES
BIKE SPACES REQUIRED	4 BIKE SPACES	8 BIKE SPACES
MOTORCYCLE PARKING PROV.	6 BIKE SPACES	6 BIKE SPACES
MOTORCYCLE PARKING REQ.	3 BIKE SPACES	5 BIKE SPACES

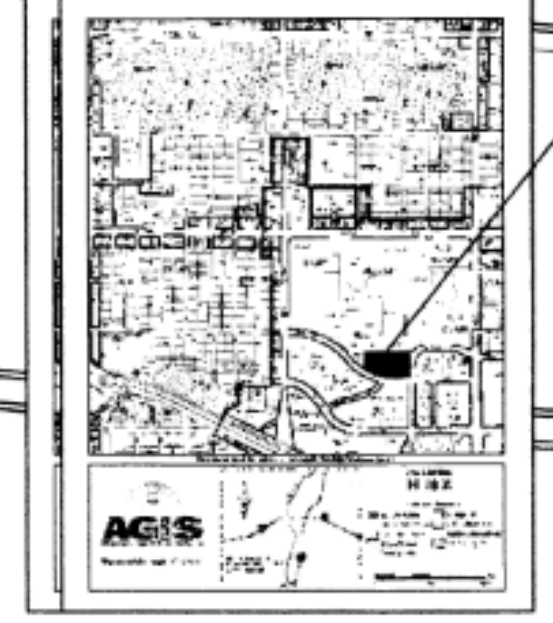

PROJECT NUMBER: PR-2023-09115  
 Application Number: SI-2023-01388

Is an Infrastructure List required? ( ) Yes (X) No. If yes, then a set of approved DRC plans with a work order is required for any construction within Public Right-of-Way or for construction of public improvements.

DFT SITE DEVELOPMENT PLAN APPROVAL:

Ernest Amisio  
 Traffic Engineering, Transportation Division  
 ABCWUA  
 Whig Baker  
 Parks and Recreation Department  
 Hegen Chan  
 Hydrology  
 Code Enforcement

Environmental Health Department (conditional)  
**SEE SHEET 3**  
 Solid Waste Management  
 Planning Department

Sep 1, 2023  
 Date  
 Sep 11, 2023  
 Date  
 Sep 1, 2023  
 Date  
 Sep 1, 2023  
 Date  
 Sep 5, 2023  
 Date  
 Date  
 Sep 11, 2023  
 Date

6-20-2023 AMENDMENTS TO REMOVE TRACT B-1-A-1 FROM SITE PLAN AND TO ADD A PERIMETER SECURITY FENCE ON TRACT A-2-B-1-A

**SITE PLAN FOR BUILDING PERMIT**



**ADMINISTRATIVE AMENDMENT**  
 File # 2023-1080/81 Project # 1000631  
 Vacation of easement, lot line relocation, +2,600 sq. ft. bldg. addition  
 Approved by: [Signature] DATE: 24 Nov '09

**REVISION**

REV	DATE	BY
1		
2		
3		
4		
5		

**MODULUS ARCHITECTS**  
 2325 SAN PEDRO N.E. SUITE 2-B  
 ALBUQUERQUE, NEW MEXICO 87110  
 PHONE (505) 338-1499 FAX (505) 338-1498  
 TOLL FREE 1-866-224-2161

**UPTOWN LOOP NE**

PROJECT TITLE: 6301-8401 UPTOWN BLVD. NE  
 N.W.C. OF UPTOWN LOOP BLVD. AND UPTOWN LOOP N.E. ALBUQUERQUE, NEW MEXICO  
 DRAWN BY: S  
 JOB NO.: 6301-UPTOWN  
 SHEET TITLE: SP-BUILDING PERMIT

DATE: \_\_\_\_\_  
 SCALE: AS NOTED  
**BP1**

AA-1000631

06/28/2023

REVISIONS



NOT FOR  
CONSTRUCTION

NOTES

DRAWN BY CW  
REVIEWED BY OK  
DATE 06/28/2023  
PROJECT NO #23-0002

NORTH + SCALE

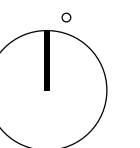

DRAWING NAME  
**FENCE & GATE ELEVATIONS**

**A2.0**



NOTE: PHOTO IS AN EXAMPLE OF A SIMILAR SCREENED GATE / FENCE INSTALLATION. NOT REPRESENTATIVE OF FINAL DESIGN

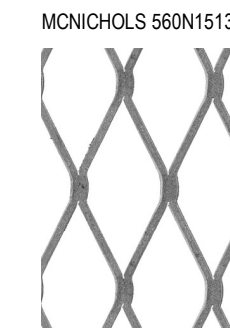

EXPANDED METAL ON FENCE IS 1-1/2" N013 FLATTENED (83% OPEN), MCNICHOLS 560N1513 OR SIMILAR (WHERE REQUIRED FOR SAFETY NOT SECURITY)

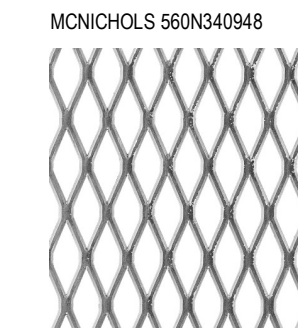

EXPANDED METAL ON GATE IS 3/4" N09 FLATTENED (64% OPEN), MCNICHOLS 560N340948 OR SIMILAR (WHERE REQUIRED FOR SECURITY)

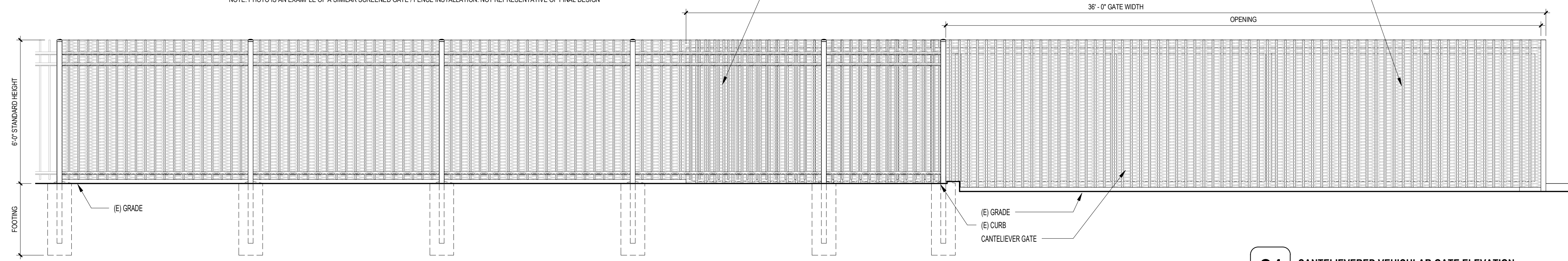

**C4** CANTILEVERED VEHICULAR GATE ELEVATION  
3/8" = 1'-0"

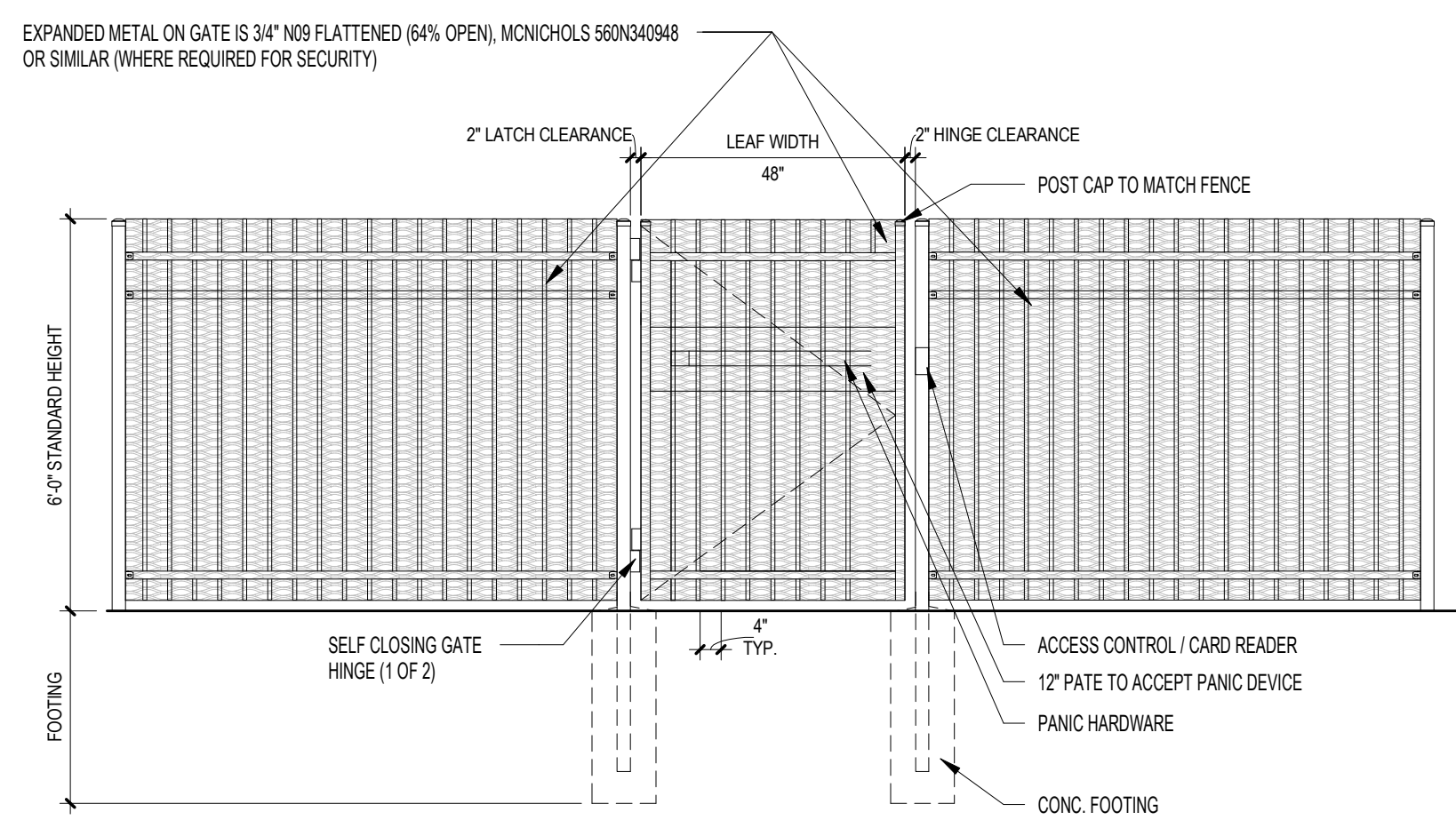

**B2** PEDESTRIAN GATE DETAIL  
3/8" = 1'-0"

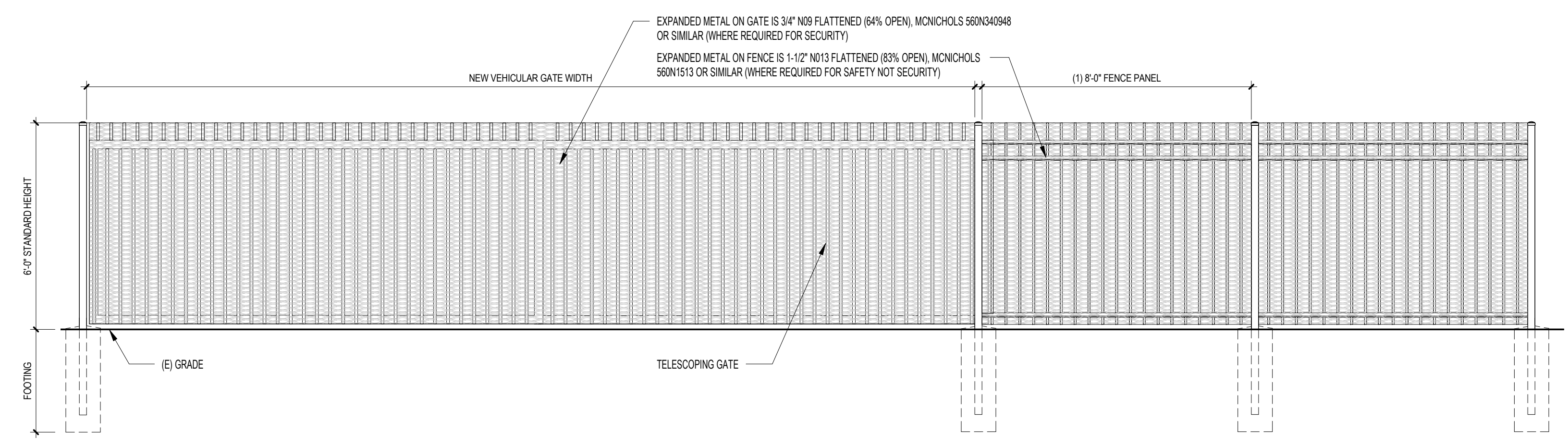

**B4** TELESCOPING VEHICULAR GATE ELEVATION  
3/8" = 1'-0"

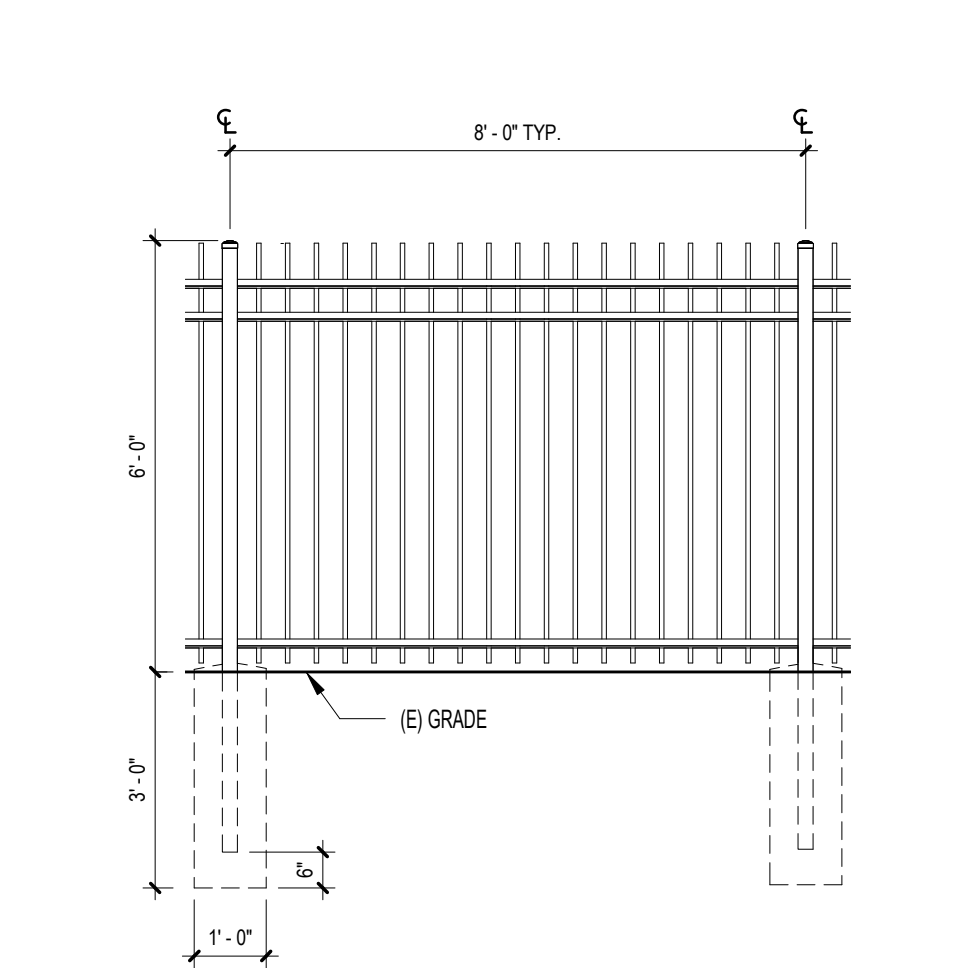

**A1** 6 FOOT FENCE ELEVATION  
3/8" = 1'-0"

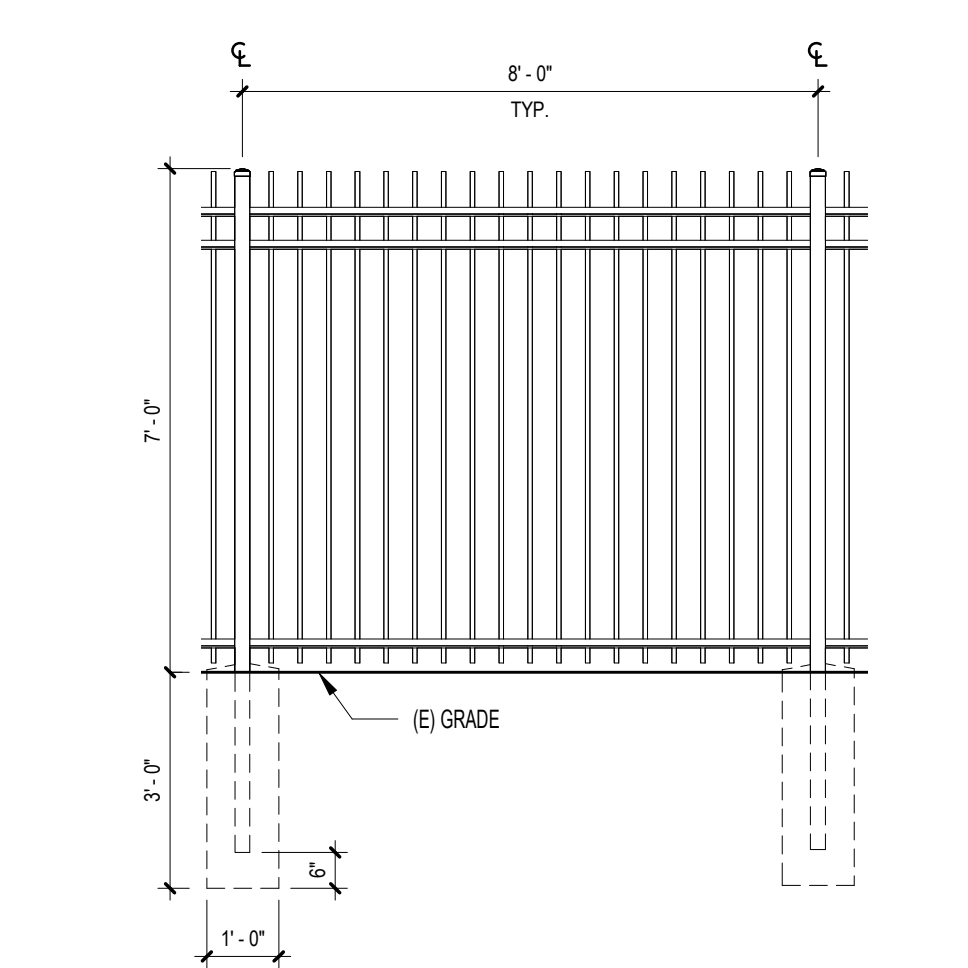

**A2** 7 FOOT FENCE ELEVATION  
3/8" = 1'-0"

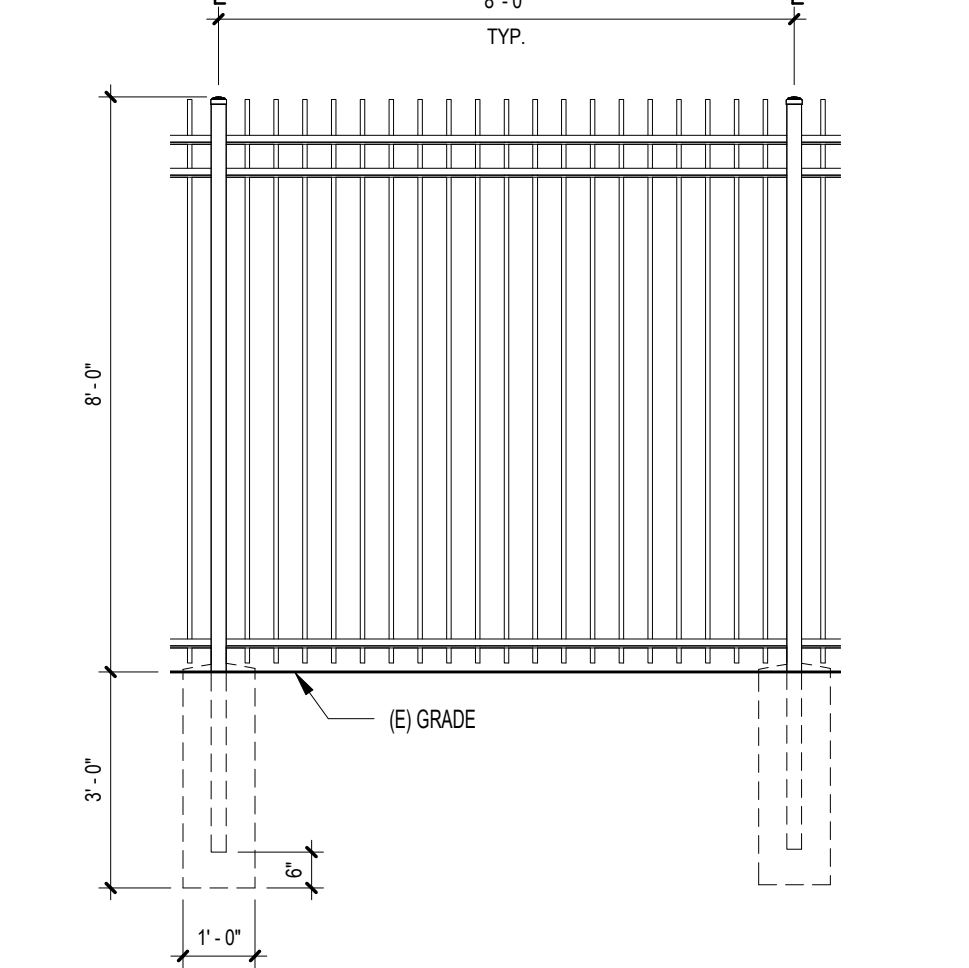

**A3** 8 FOOT FENCE ELEVATION  
3/8" = 1'-0"

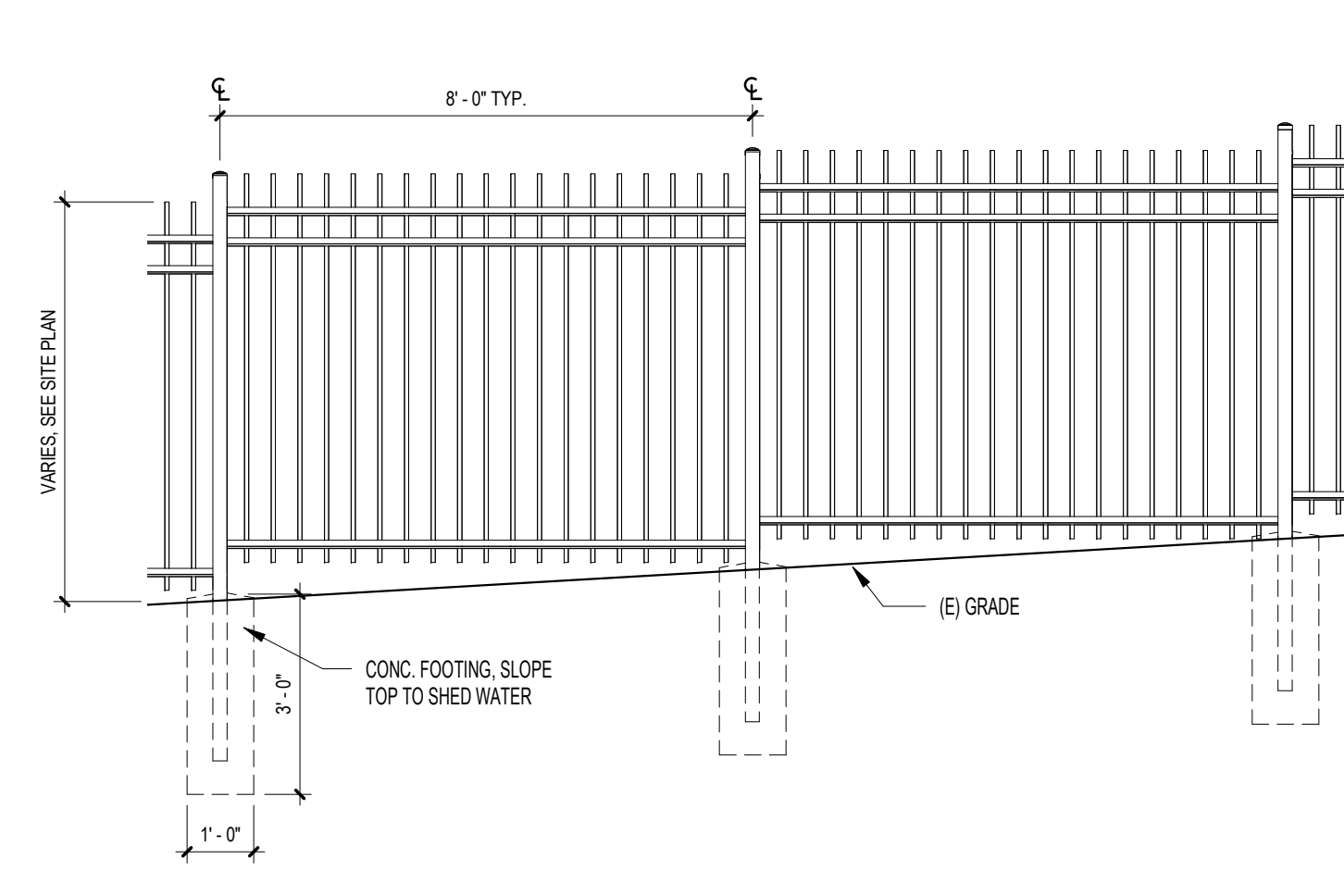

**A4** TYP. STEPPED FENCE ELEVATION  
3/8" = 1'-0"

Albuquerque Control Survey Monument 176-H18  
 New Mexico State Plane Coordinates, Central Zone (NAD83) as published:  
 File: 1543.620.222  
 Inv: 1.465.150.724  
 Ground to grid factor = 0.999661845  
 Date Alpha = 007109  
 Elevation = 5283.415 (NAVD83)

- LEGEND**
- WALL
  - SANITARY SEWER MANHOLE
  - DRAIN INLET
  - TELEPHONE PEDESTAL
  - GROUND LIGHT PEDESTAL
  - CITY PEDESTAL
  - SIDEWALK DRAIN COVER
  - LIGHT POLE
  - WATER METER
  - ROOF DRAIN
  - HANDICAP PARKING SPACE
  - SPOT ELEVATION

- KEYED NOTE:**
- ① INDICATES PROPOSED AREA OF ADDITION
  - ② EXISTING LIGHT POLE LOCATION TO REMAIN
  - ③ CONC. SIDEWALK RE: DET 13/A1.1 RE: SITE PLAN FOR JOINT LAYOUT
  - ④ INDICATES EXISTING CAR PARKING CANOPY TO REMAIN
  - ⑤ INDICATES PROPOSED CAR PARKING CANOPY ADDITION TO MATCH EXISTING CANOPY
  - ⑥ EXISTING 14' UTILITY EASEMENT PER PLAT FILED MAY 18, 1981 PLAT BOOK C18, FOLIO B1 TO BE VACATED
  - ⑦ EXISTING LOT LINE TO BE VACATED
  - ⑧ SIDEWALK FLUME RE: 3/A1.1 FOR DET INFO
  - ⑨ SIDEWALK/CURB DETAIL RE: 8/A1.1 FOR DET INFO
  - ⑩ CROSSWALK PAINT DESIGNATION RE: 12/A1.1 FOR DET INFO
  - ⑪ BIKE RACK LOCATION RE: 1/A1.1 FOR DET INFO
  - ⑫ MOTORCYCLE SIGNAGE RE: 9A/A1.1 FOR DET INFO
  - ⑬ CONC. PEDESTRIAN END ISLAND RAMP RE: 8/A1.2 FOR DET INFO
  - ⑭ CONC. PEDESTRIAN TAPERED RAMP RE: 6A/A1.1 FOR DET INFO
  - ⑮ PAINTED SIGNING AS INDICATED WITHIN SITE PLAN - MIN 16" HIGH LETTERING
  - ⑯ REFUSE ENCLOSURE RE: 1 THRU 7 /A1.2 FOR DET INFO
  - ⑰ WHEEL STOP RE: 10 /A1.1 FOR DET INFO
  - ⑱ BENCH LOCATION RE: 4/A1.1 FOR DET INFO

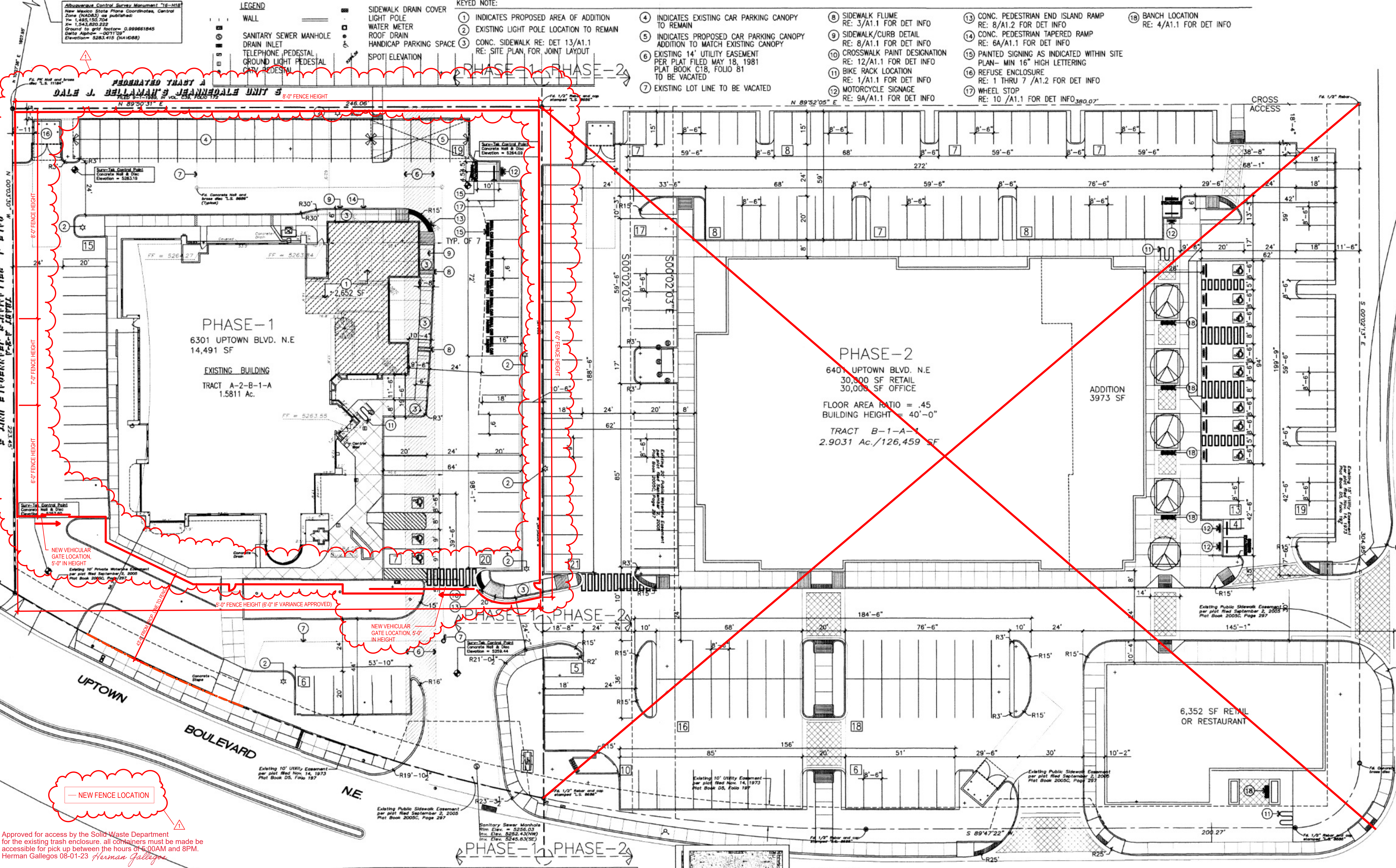

Approved for access by the Solid Waste Department for the existing trash enclosure. all containers must be made accessible for pick up between the hours of 5:00AM and 8PM.  
 Herman Gallegos 08-01-23 *Herman Gallegos*

NEW FENCE LOCATION

6-20-2023: AMENDMENTS TO REMOVE TRACT B-1-A-1 FROM SITE PLAN AND TO ADD A PERIMETER SECURITY FENCE ON TRACT A-2-B-1-A

**ADMINISTRATIVE AMENDMENT**  
 File # 2011-1089/Project # 10.00631  
 Vacation of easement, lot line relocation, ±2,600 sq. Ft. bldg. addition  
*Result Books* 24 Nov '09  
 APPROVED BY DATE

SITE DATA TABLE	PHASE-1	PHASE-2
LEGAL DESCRIPTION	TRACT A-2-B-1-A	TRACT B-1-A-1
TOTAL ACREAGE:	1.5811 Acres±	2.9031 Acres±
EXISTING ZONING:		
BUILDING SIZE:	RE: SITE	RE: SITE
FAR:	EXISTING FAR= 21%	EXISTING FAR= 45%
EXISTING USES:	OFFICE	OFFICE/RETAIL
TOTAL PARKING PROVIDED:	67 SPACES	177 SPACES
TOTAL PARKING REQ:	67 SPACES	177 SPACES
HC REQ:	3 H.C. (INCLUDING 2 VAN ACCESSIBLE)	8 H.C. (INCLUDING 4 VAN ACCESSIBLE)
HC PROVIDED:	11 H.C. (INCLUDING 6 VAN ACCESSIBLE)	11 H.C. (INCLUDING 6 VAN ACCESSIBLE)
BIKE SPACES PROVIDED:	5 BIKE SPACES	10 BIKE SPACES
BIKE SPACES REQUIRED:	4 BIKE SPACES	8 BIKE SPACES
MOTORCYCLE PARKING PROVIDED:	6 BIKE SPACES	6 BIKE SPACES
MOTORCYCLE PARKING REQ:	3 BIKE SPACES	5 BIKE SPACES

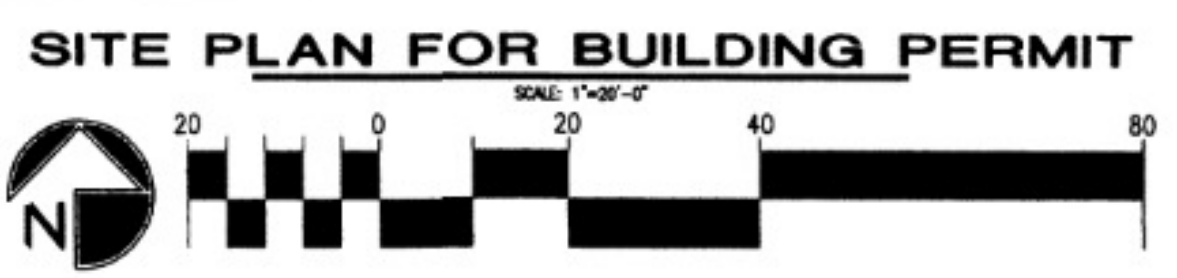
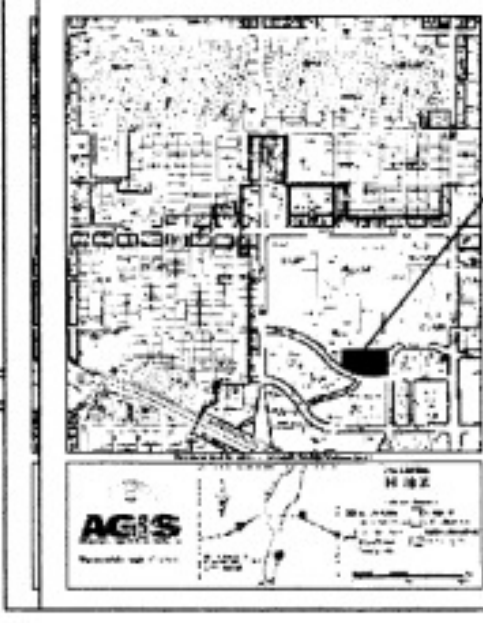

**REVISION**

REV	DATE	BY
1		
2		
3		
4		
5		
6		

**MODULUS ARCHITECTS**  
 2925 SAN PEDRO N.E. SUITE 2-B  
 ALBUQUERQUE, NEW MEXICO 87110  
 PHONE (505) 338-1499 FAX (505) 338-1498  
 TOLL FREE 1-866-224-2161

**SP-BUILDING PERMIT**

PROJECT TITLE: 6301-6401 UPTOWN BLVD. N.E. N.W.C. OF UPTOWN LOOP BLVD. AND UPTOWN LOOP N.E. ALBUQUERQUE, NEW MEXICO  
 DRAWN BY: S  
 PROJECT MANAGER: STEPHEN DUNBAR, AIA 6301-UPTOWN  
 SHEET TITLE: SP-BUILDING PERMIT

DATE: \_\_\_\_\_  
 SCALE: AS NOTED  
**BP1**

AA-000631











# PR-2023-009115\_SI-2023-01388\_Site\_Plan\_Aproved\_8-30-23

Final Audit Report

2023-09-11

Created:	2023-09-01
By:	Jay Rodenbeck (jrodenbeck@cabq.gov)
Status:	Signed
Transaction ID:	CBJCHBCAABAAJkZ36kqC4G_A50WKbws5hrQnYQMG32Le

## "PR-2023-009115\_SI-2023-01388\_Site\_Plan\_Aproved\_8-30-23" History

-  Document created by Jay Rodenbeck (jrodenbeck@cabq.gov)  
2023-09-01 - 7:59:21 PM GMT- IP address: 198.206.237.4
-  Document emailed to Jolene Wolfley (jwolfley@cabq.gov) for signature  
2023-09-01 - 8:02:47 PM GMT
-  Document emailed to Ernest Armijo (earmijo@cabq.gov) for signature  
2023-09-01 - 8:02:47 PM GMT
-  Document emailed to Tiequan Chen (tchen@cabq.gov) for signature  
2023-09-01 - 8:02:47 PM GMT
-  Document emailed to David G. Gutierrez (dggutierrez@abcwua.org) for signature  
2023-09-01 - 8:02:47 PM GMT
-  Document emailed to Jeff Palmer (jppalmer@cabq.gov) for signature  
2023-09-01 - 8:02:48 PM GMT
-  Document emailed to Whitney Phelan (wphelan@cabq.gov) for signature  
2023-09-01 - 8:02:48 PM GMT
-  Email viewed by Tiequan Chen (tchen@cabq.gov)  
2023-09-01 - 8:07:17 PM GMT- IP address: 198.175.173.4
-  Document e-signed by Tiequan Chen (tchen@cabq.gov)  
Signature Date: 2023-09-01 - 8:08:50 PM GMT - Time Source: server- IP address: 198.175.173.4
-  Email viewed by Ernest Armijo (earmijo@cabq.gov)  
2023-09-01 - 8:43:34 PM GMT- IP address: 198.206.237.4

 Document e-signed by Ernest Armijo (earmijo@cabq.gov)  
Signature Date: 2023-09-01 - 8:43:49 PM GMT - Time Source: server- IP address: 198.206.237.4

 Email viewed by Jolene Wolfley (jwolfley@cabq.gov)  
2023-09-01 - 9:45:24 PM GMT- IP address: 143.120.133.169

 Email viewed by Whitney Phelan (wphelan@cabq.gov)  
2023-09-01 - 9:59:30 PM GMT- IP address: 172.59.1.233

 Document e-signed by Whitney Phelan (wphelan@cabq.gov)  
Signature Date: 2023-09-01 - 10:00:05 PM GMT - Time Source: server- IP address: 172.59.1.233

 Email viewed by Jeff Palmer (jppalmer@cabq.gov)  
2023-09-05 - 2:43:09 PM GMT- IP address: 143.120.132.73

 Document e-signed by Jeff Palmer (jppalmer@cabq.gov)  
Signature Date: 2023-09-05 - 2:43:21 PM GMT - Time Source: server- IP address: 143.120.132.73

 Email viewed by David G. Gutierrez (dggutierrez@abcwua.org)  
2023-09-11 - 2:40:40 PM GMT- IP address: 142.202.67.2

 New document URL requested by David G. Gutierrez (dggutierrez@abcwua.org)  
2023-09-11 - 2:40:43 PM GMT- IP address: 142.202.67.2

 New document URL requested by David G. Gutierrez (dggutierrez@abcwua.org)  
2023-09-11 - 2:40:56 PM GMT- IP address: 142.202.67.2

 Document e-signed by David G. Gutierrez (dggutierrez@abcwua.org)  
Signature Date: 2023-09-11 - 2:44:05 PM GMT - Time Source: server- IP address: 142.202.67.2

 New document URL requested by Jolene Wolfley (jwolfley@cabq.gov)  
2023-09-11 - 8:12:42 PM GMT- IP address: 143.120.133.169

 Email viewed by Jolene Wolfley (jwolfley@cabq.gov)  
2023-09-11 - 8:13:00 PM GMT- IP address: 143.120.133.169

 Document e-signed by Jolene Wolfley (jwolfley@cabq.gov)  
Signature Date: 2023-09-11 - 8:13:32 PM GMT - Time Source: server- IP address: 143.120.133.169

 Agreement completed.  
2023-09-11 - 8:13:32 PM GMT