



Mountain Rd. Rehabilitation Facility - Albuquerque

(Mountain Rd. / I-25)

Traffic / Safety Study

September 16, 2025

FINAL



A handwritten signature in blue ink that reads "Terry O. Brown".

Terry O. Brown, P.E.
5571 Midway Park Pl. NE
Albuquerque, NM 87109
(505) 883-8807



A handwritten signature in blue ink that reads "Ron R. Bohannon".

Ronald R. Bohannon, P.E.
5571 Midway Park Pl. NE
Albuquerque, NM 87109
(505) 883-8807

Presented to:

City of Albuquerque
Transportation Development Section
&
NM DOT District 3

Prepared for:

Mrs. Megan Veeren
Alb. Rehab Real Estate Investors, LLC

It is a proposed 48 bed rehabilitation center. Access to the subdivision will be three driveways (one existing and two proposed) onto Woodward Pl. and Mountain Rd. as shown below:

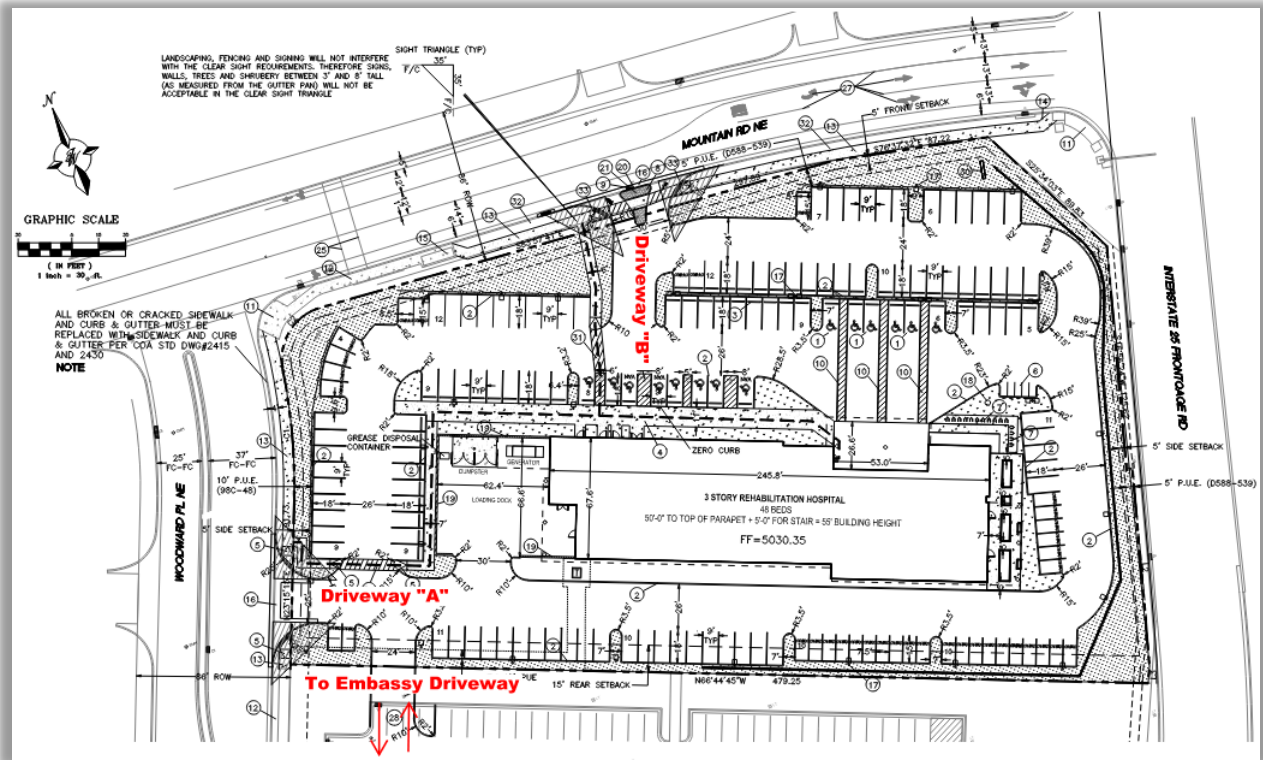

(Also, see Site Plan on Page A-3 in the Appendix of this report which shows easement to Embassy Suites North driveway).

This Study utilized the Institute of Transportation Engineers' (ITE) Trip Generation Manual (11th Edition) to calculate the trip generation rates for the project. Historically, it has been demonstrated that a facility such as this one generates trips much like that of ITE Land Use 620 (Nursing Home). This was verified by a traffic count conducted for a Skilled Nursing Facility located along Horizon Blvd. north of Alameda Blvd. in 2012 (Eduro Healthcare). The following table summarizes the trip generation rates utilized in this Study (Also see Page A-7 in the Appendix):

Rehabilitation Hospital (Mountain Rd. / I-25 W. Frontage Rd.)

Trip Generation Data (ITE Trip Generation Manual - 11th Edition)

USE (ITE CODE)	DESCRIPTION	24 HR VOL	A. M. PEAK HR.		P. M. PEAK HR.		
		GROSS	ENTER	EXIT	ENTER	EXIT	
Summary Sheet		Units					
Nursing Home (620)		64.00	432	27	8	15	22

No adjustment was made for pass-by trips nor internal capture. Neither of those adjustments would be appropriate for this type of facility. Also, the trip generation rate for this study is based on a 64,000 s.f. facility when, in fact, the plan has been slightly modified so that the actual

proposed building is approximately 55,100 s.f. of gross floor area. Therefore, the analysis in this Study will be considered slightly on the conservative side in that it assumes the trip generation rate to be marginally higher than what it will actually generate.

The new trips generated by the proposed Mountain Rd. Rehabilitation Facility were distributed over the study area of the adjacent street network proportional to the distribution of population regionally inversely proportional to the distance of the MRCOG Subarea from the project. Trip assignments were made consistent with the result of the trip distribution analysis and logical routing.

The Implementation Year (2025) NO BUILD volumes analysis was performed based on recently acquired traffic counts (turning movements volumes) at the intersections in the study area grown annually from 2024 to 2025 at a historic background traffic growth rate determined based on growth trend of existing traffic volumes from the Mid-Region Council of Governments. The Implementation Year (2025) BUILD volumes were derived by adding traffic from the proposed Mountain Rd. Rehabilitation Facility to the Implementation Year (2025) NO BUILD volumes.

The trip generation rate for this project alone does not warrant a Traffic Impact Study in the City of Albuquerque. The currently enforced threshold for a Traffic Impact Study by the New Mexico Department of Transportation is any land development project that generates more than 99 trips per hour during the AM or PM Peak Hour (total trips entering and exiting). The Mountain Rd. Rehab Facility only generates 37 trips per hour (entering and exiting). However, this Study was performed as a response to neighborhood concerns expressed at public meeting and / or in written correspondence to the City.

Analyses of the signalized and unsignalized intersections in this Study were performed using Trafficware's Synchro 12 (version 12.2.3.12). Signalized intersection analyses were performed using existing signal timing settings furnished by the City of Albuquerque.

Even though a Traffic Impact Study is not warranted for this project, the New Mexico Department of Transportation expressed during the scoping meeting that they had concerns about the safety at the signalized intersection of Mountain Rd. / I-25 W. Frontage Rd. The neighborhoods had also expressed safety concerns in the study area, some reporting that there were fatalities on Mountain Rd. and a problem with cut-through traffic. The crash analysis for this Study proved that was not the case. Included in the Appendix is the notes from the January 2025 meeting. Therefore, this Study will address safety issues focusing on the intersection of Mountain Rd. / I-25 W. Frontage Rd. specifically.

A summary of operational analysis results are included in the following table:

Executive Summary Results Table
Mountain Rd. Rehabilitation Center (Mountain Rd. / I-25)

Intersection No. / Name	Signalization	Conditions	2025 Conditions		2035 Conditions	
			AM Peak	PM Peak	AM Peak	PM Peak
1 - Mountain Rd. / I-25 W. Frmtg Rd.	Signalized	NO BUILD	B - 12.3	B - 10.0	B - 13.4	B - 10.1
		BUILD	B - 12.5	B - 10.1	B - 13.6	B - 10.2
2 - Lomas Blvd. / I-25 W. Frmtg Rd.	Signalized	NO BUILD	C - 24.1	C - 21.4	C - 24.5	C - 21.7
		BUILD	C - 24.1	C - 21.4	C - 24.5	C - 21.8
3 - Lomas Blvd. / Woodward Pl.	Unsignalized	NO BUILD	D - 27.4	D - 27.1	D - 29.3	C - 29.3
		BUILD	D - 27.7	D - 27.3	D - 29.6	D - 29.4
4 - Mountain Rd. / Woodward Pl.	Unsignalized	NO BUILD	C - 19.7	B - 13.2	C - 21.0	B - 13.6
		BUILD	C - 20.9	B - 13.6	C - 22.4	B - 14.0
5 - Mountain Rd. / AHS W. Driveway	Unsignalized	NO BUILD	C - 17.7	C - 18.0	C - 19.2	C - 19.7
		BUILD	C - 17.8	C - 18.1	C - 19.3	C - 19.9
6 - Mountain Rd. / AHS Cntr Drwy.	Unsignalized	NO BUILD	B - 13.0	B - 11.2	B - 13.3	B - 11.3
		BUILD	B - 13.1	B - 11.3	B - 13.5	B - 11.4
7 - Mountain Rd. / AHS E. Driveway	Unsignalized	NO BUILD	C - 23.6	C - 17.3	D - 26.5	C - 18.7
		BUILD	C - 24.5	C - 17.8	D - 27.7	C - 19.4

Executive Summary Results Table
Mountain Rd. Rehabilitation Center (Mountain Rd. / I-25)

8 - Embassy Drwy / Woodward Pl.	Unsignalized	NO BUILD	A - 9.6	A - 9.4	A - 9.9	A - 9.4
		BUILD	B - 10.1	A - 9.6	B - 10.2	A - 9.6
9 - Driveway "A" / Woodward Pl.	Unsignalized	NO BUILD	N/A	N/A	N/A	N/A
		BUILD	A - 8.6	A - 8.8	A - 8.6	A - 8.8

A safety analysis was conducted by collecting crash data from the New Mexico Department of Transportation (Safety Bureau) for the years 2018 through 2022.

In summary, the proposed development does not have a significant adverse impact to the adjacent transportation system provided the recommendations of this study are implemented. The operational aspects at the intersections in the study area. are not significantly adversely impacted nor are safety impacts significantly impacted. The recommendations below are not primarily based on operational analysis but rather on the safety analysis. In summary, the recommendations of this study are:

Recommendations:

General – Construction of the Mountain Rd. Rehab Project and landscaping shall maintain adequate sight distances at access points and contiguous intersections.

Access – Project access should be comprised of two driveways on Woodward Pl. - one full access driveway (Embassy Suites Driveway) approximately 370 feet south of Mountain Rd. (centerline to centerline) shared with Embassy Suites Hotel, one right-in, right-out only driveway (Driveway “A”) on the east side of Woodward Pl. located approximately 180 feet south of Mountain Rd. (centerline to centerline), plus one right-in, right-out only driveway (Driveway “B”) on the south side of Mountain Rd. located approximately 250 feet east of Woodward Pl. (centerline to centerline). See Site Plan on Page A-3 in Appendix.

Mountain Rd. / I-25 W. Frontage Rd. – This safety component of this Study recommends three improvements to improve safety characteristics at Mountain Rd. / I-25 W. Frontage Rd.:

- 1) Construct new yellow backplates on all signal heads at the intersection to enhance visibility.
- 2) Construct new laneage signs on the mastarm facing southbound traffic on the frontage road.
- 3) Mask the signal indicators at the east frontage road so as not to be visible from the west frontage road.
- 4) The City of Albuquerque has reported that the southbound shoulder on the I-25 W. Frontage Rd. is currently being used as a right turn lane by some drivers. The City of Albuquerque will require the developer to construct new cross-hatching in the shoulder from the stop bar to 250 feet north of the stop bar.

It should be noted that the City of Albuquerque Traffic Operations has made plans to install detection equipment that detects oncoming speeding vehicles and adjusts signal timing appropriately.

**Mountain Rd. Rehabilitation Facility
(Mountain Rd. / I-25)
Traffic Study / Safety Study**

Contents

Executive Summary 1

 Recommendations:..... 5

Introduction 1

Description of Proposed Development 2

Study Area Conditions 3

Analysis of Existing Conditions 5

Analysis of Implementation Year Conditions 5

 Traffic Projections..... 5

 Traffic Analysis – Implementation Year (2025) 7

Discussion of Implementation Year Analysis 18

Discussion of Horizon Year Analysis **Error! Bookmark not defined.**

 Impact Assessment 18

 Access Design Specifications 18

Safety Analysis 19

Summary of Deficiencies and Anticipated Impacts 23

Recommendations 23

APPENDIX 27

**Mountain Rd. Rehabilitation Facility
(Mountain Rd. / I-25)
Traffic Study / Safety Study**

Introduction

The purpose of this study is to evaluate the transportation conditions before and after implementation of the proposed Mountain Rd. Rehabilitation Facility, demonstrate the impact of the development on the adjacent transportation system and evaluate / address safety issues within the study area, especially at the signalized intersection of Mountain Rd. / I-25 W. Frontage Rd. This study is not warranted by the City of Albuquerque or the New Mexico Department of Transportation (and therefore, is not a requirement), but was performed in response to neighborhood concerns expressed at public meetings related to the project.

The proposed development is located at the southwest corner of Mountain Rd. / I-25 W. Frontage Rd. (Also see Page A-1 and A-2 in the Appendix).

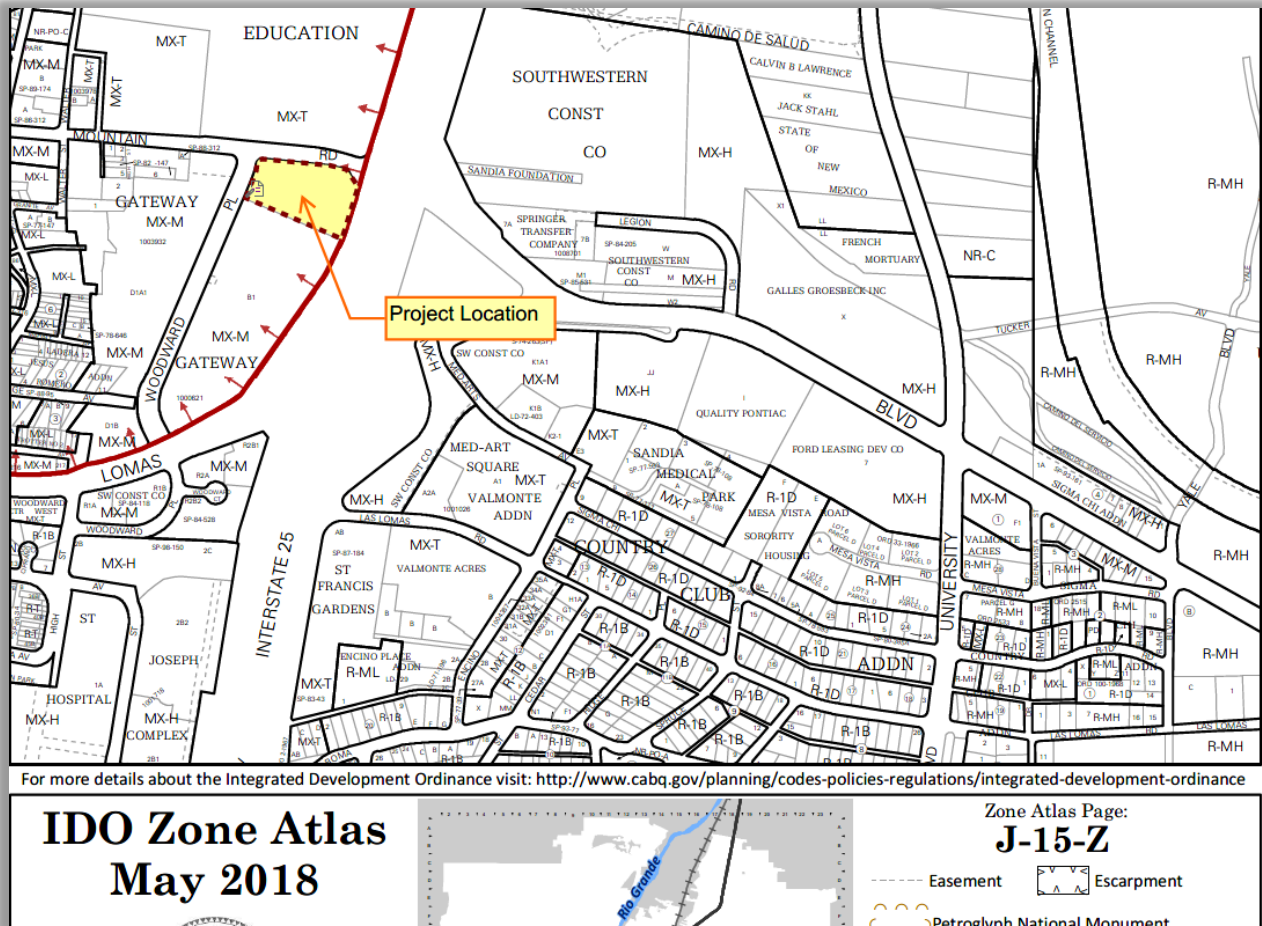

Description of Proposed Development

It is a proposed 48 bed rehabilitation center. Access to the subdivision will be three driveways (one existing and two proposed) onto Woodward Pl. and Mountain Rd. as shown below:

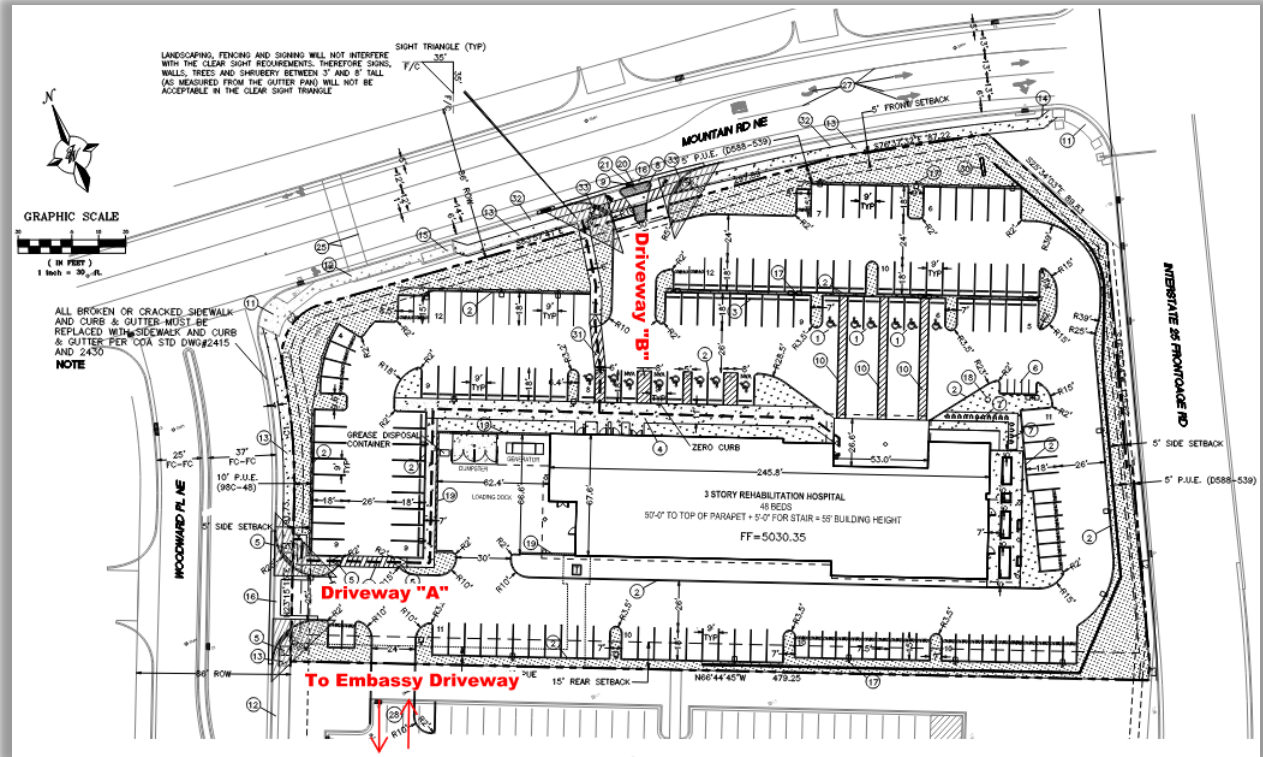

(Also, see Subdivision Plan on Page A-3 in the Appendix of this report).

This Study utilized the Institute of Transportation Engineers' (ITE) Trip Generation Manual (11th Edition) to calculate the trip generation rates for the project. Historically, it has been demonstrated that a facility such as this one generates trips much like that of ITE Land Use 620 (Nursing Home). This was verified by a traffic count conducted for a Skilled Nursing Facility located along Horizon Blvd. north of Alameda Blvd. in 2012 (Eduro Healthcare). The following table summarizes the trip generation rates utilized in this Study (Also see Page A-7 in the Appendix):

Rehabilitation Hospital (Mountain Rd. / I-25 W. Frontage Rd.)

Trip Generation Data (ITE Trip Generation Manual - 11th Edition)

USE (ITE CODE)	DESCRIPTION	24 HR VOL GROSS	A. M. PEAK HR.		P. M. PEAK HR.		
			ENTER	EXIT	ENTER	EXIT	
Summary Sheet							
Nursing Home (620)		Units 64.00	432	27	8	15	22

No adjustment was made for pass-by trips nor internal capture. Neither of those adjustments would be appropriate for this type of facility. Also, the trip generation rate for this study is based

on a 64,000 s.f. facility when, in fact, the plan has been slightly modified so that the actual proposed building is approximately 55,100 s.f. of gross floor area. Therefore, the analysis in this Study will be considered slightly on the conservative side in that it assumes the trip generation rate to be marginally higher than what it will actually generate.

The project will be required to comply with the requirements of City of Albuquerque with regard to the overall development. The Traffic Study / Safety Study includes the analysis of the signalized intersections of Mountain Rd. / I-25 W. Frontage Rd. and Lomas Blvd. / I-25 W. Frontage Rd. which are maintained by the New Mexico Department of Transportation, as well as the intersections of Lomas Blvd. / Woodward Pl., Mountain Rd. / Woodward Pl., Mountain Rd. / Albuquerque High School West Driveway, Mountain Rd. / Albuquerque High School Center Driveway, Mountain Rd. / Albuquerque High School East Driveway, Embassy Suites Driveway / Woodward Pl. and Driveway "A" / Woodward Pl., and with the requirements of the New Mexico Department of Transportation with regard to transportation issues along the I-25 West Frontage Rd.

The Mountain Rd. Rehabilitation Facility will be constructed in one phase. This study will analyze an implementation year of 2025. No horizon year analysis is required.

The development will be accessed via three unsignalized driveways listed as follows:

- Full access Embassy Suites Driveway to be shared with the Mountain Rd. Rehabilitation Facility via shared access easement.
- New right-in, right-out driveway (Driveway "A") on the east side of Woodward Pl. located approximately 180 feet south of Mountain Rd. (centerline to centerline).
- New right-in, right-out driveway (Driveway "B") on the south side of Mountain Rd. located approximately 250 feet east of Woodward Pl.

See proposed site development plan on Page A-3 in the Appendix depicting access intersection locations:

Study Area Conditions

A Traffic Impact Study Scoping Meeting for this project was held with the City of Albuquerque and the New Mexico Department of Transportation District Office on Thursday, February 29, 2024. The City of Albuquerque (Matthew Grush) and the NM DOT (Margaret Haynes) reported that they would not require a Traffic Impact Study since the project does not meet their warrants for such a study. The consultant argued that a Traffic Study was recommended to address neighborhood concerns expressed at public meetings and via correspondence to the City of Albuquerque. The New Mexico Department of Transportation (Margaret Haynes) stated that since there was going to be a voluntary Traffic Study, she would like to see a safety analysis at the signalized intersection of Mountain Rd. / I-25 West Frontage Rd. Neighborhood concerns also focused on safety issues.

The study area would also include the following list of intersections to be analyzed in the Traffic Impact Study:

1. Mountain Rd. / I-25 W. Frontage Rd.. – signalized
2. Lomas Blvd. / I-25 W. Frontage Rd. – signalized
3. Lomas Blvd. / Woodward Pl. – unsignalized
4. Mountain Rd. / Woodward Pl. – unsignalized
5. Mountain Rd. / Albuquerque High School (AHS) West Driveway – unsignalized
6. Mountain Rd. / AHS Center Driveway (Driveway “B”) – unsignalized
7. Mountain Rd. AHS East Driveway - unsignalized
8. Embassy Suites Driveway / Woodward Pl. - unsignalized
9. Driveway “A” / Woodward Pl. - unsignalized

This scope of study was based on the assumption that the parcel in question would be developed as a Rehabilitation Facility as shown on the proposed site plan.

There is no other known land development project in the area which needs to be incorporated into the background traffic model for this study

This project is served by public transit services in the area; specifically, Route #5 (Montgomery / Carlisle / Lomas). This route serves the area at approximately 45 minute intervals weekdays from approximately 5:25 am until about 9:00 pm, Saturdays from approximately 7:30 am until 7:00 pm, and Sundays from approximately 8:30 am until 5:30 pm.

There is an existing Bike Lane on Mountain Rd. from Edith Blvd. east to the I-25 Frontage Rd. based on the 2040 Metropolitan Transportation Plan (2040 Long Range Bikeway System) as shown on the portion of the map on Appendix Page A-5.

There are intermittent pedestrian facilities in the project area – intermittent permanent and temporary curb & gutter and sidewalks along the roads.

Lomas Blvd., a City of Albuquerque roadway facility, is classified as a Regional Principal Arterial Roadway on the Mid-Region Council of Government’s Futures 2040 Long Range Roadway System Map. It is generally a four-lane urban-type roadway with curb and gutter & sidewalks and raised medians. The posted speed limit along Lomas Blvd. in the study area is 35 MPH.

Mountain Rd. west of I-25 is classified as a Major Collector Roadway on the Mid-Region Council of Government’s Futures 2040 Long Range Roadway System Map. It is generally a two lane undivided roadway between Edith Blvd. and Interstate 25 with a posted speed limit of 25 MPH in the study area.

Woodward Pl. is not classified on the Mid-Region Council of Government's Futures 2040 Long Range Roadway System Map. It is considered a local roadway. It is generally a four lane divided roadway with curbs and gutters on both sides as well as a raised median in the center. The assumed speed limit is 25 MPH.

Analysis of Existing Conditions

Due to the fact that the Implementation Year is only about one year in the future, no existing analysis was performed. The Implementation Year NO BUILD analyses should closely approximate existing conditions. Existing traffic volumes (turning movement counts) were collected at the intersections of Mountain Rd. / I-25 W. Frontage Rd., Lomas Blvd. / I-25 W. Frontage Rd., Lomas Blvd. / Woodward Pl., Mountain Rd. / Woodward Pl., Mountain Rd. / Albuquerque High School West Driveway, Mountain Rd. / Albuquerque High School Center Driveway, Mountain Rd. / Albuquerque High School East Driveway, and Embassy Suites driveway / Woodward Pl., and are included on Appendix Pages A-361 thru A-368.

Existing signal timing / phasing sheets are in the Appendix on Pages A-355 thru A-360. Generally speaking, the signalized intersections of Mountain Rd. / I-25 W. Frontage Rd. and Lomas Blvd. / I-25 W. Frontage Rd. are both fully actuated traffic signal for all turning movements.

Analysis of Implementation Year Conditions

Traffic Projections

Background traffic volumes for the implementation year were forecast by applying the calculated annual background traffic growth rate and applying it to recent turning movements volume data. Background annual growth rates were calculated based on Mid-Region Council of Governments' Traffic Flow Map data from 2013 to 2022. Background traffic growth rates were considered for each individual approach to an intersection that was targeted for analysis based on data from the 2013 thru 2022 Traffic Flow maps prepared by the Mid-Region Council of Governments (MRCOG). The data from those years for each approach was plotted on a graph and a linear "regression trend line" calculated using the equation format $y=mx+b$. The growth rate was determined by calculating the average volume increase per year during the time period considered and dividing that volume into the most recent AWDT used in the analysis from which future volumes will be calculated. The rate of growth of that trend line was utilized as the growth rate for each approach if that calculated rate appeared feasible. However, there were some instances where the rate indicated a negative growth trend. In those cases, an appropriate growth rate from an adjacent segment of the same roadway was considered. Due to the potential for growth in the area, it was believed that a zero percent growth rate was inappropriate for this study. Additionally, if the R^2 value of the trend line was low, other means of establishing a probable growth rate from the data accumulated was considered. Historic Growth Rate Graphs with linear

regression trendlines are shown in the Appendix on Page A-20. The appropriate annual background traffic growth rate of 0.5% was utilized in this study.

This study assumes that the development will be implemented in one phase with an implementation year of 2025.

The Gravity Model was used to determine trip distribution where primary trips for the medical land use development were distributed proportionally to the 2025 projected population centers of Subareas within the Mid-Region Council of Governments inversely proportional to the distance of the subarea centroid from the project. Employment data for the years 2016 and 2040 were taken from the 2016 / 2040 Socioeconomic Forecasts by Subareas for the Mid-Region of New Mexico supplied by the Mid-Region Council of Governments (MRCOG). Population data from the years 2016 and 2040 was interpolated linearly to obtain 2025 employment data to utilize for this analysis. Employment subareas were grouped based on the most likely major street(s) or route(s) to the subject development. The trip distribution worksheets and associated map of data analysis subzones are shown in the Appendix on Pages A-8 thru A-9. The Trip Distribution map for the Mountain Rd. Rehabilitation Facility can be found in the Appendix on Page A-10.

Trip assignments are first made on a percentage basis derived from data established in the trip distribution determination process and logical routing. Those percentages are then applied to the projected trips to determine individual traffic movements. Percentage trip assignments for Mountain Rd. Rehabilitation Facility trips are shown below and on Appendix on Pages A-11 thru A-18. No adjustments for pass-by trips on this project were applied.

The trip generation, trip distribution and trip assignments were utilized along with the existing 2024 background traffic volumes and the historical traffic growth rates to determine the Implementation year (2025) NO BUILD and BUILD volumes. See Appendix Pages A-21 thru A-146 for Projected Turning Movements Volumes Summary and Worksheets. Lane geometry, NO BUILD and BUILD volumes, and calculated levels-of-service for associated lane groups are shown on the Lanes / Volumes Analysis Tables in the following section of this report.

The City suggested at the scoping meeting for this Traffic Impact Study that this Study should consider and evaluate two alternative access scenarios for the existing intersection of Mountain Rd. / Woodward Pl. Thus, there were three scenarios for access at Mountain Rd. / Woodward Pl. evaluated in the DRAFT Study as listed below:

- **Base Case** is the analysis assuming existing geometry at Mountain Rd. / Woodward Pl.
- **Ltd. Case** is the analysis assuming the unsignalized intersection of Mountain Rd / Woodward prohibits northbound traffic. Therefore, the northbound left turn and northbound right turn movements on Woodward Pl. at Mountain Rd. are prohibited.
- **No Access Case** is the analysis assuming no vehicular connection of Woodward Pl. with Mountain Rd.

After the initial review by the City of Albuquerque (Curtis Cherne, who replaced Matt Grush), it was directed that the Ltd. Case scenario and the No Access Case scenario be eliminated from this Study.

Traffic Analysis - Implementation Year (2025)

A capacity analysis using existing traffic signal timing (see Appendix Pages A-147 thru A-354) was conducted for the Implementation Year (2025) NO BUILD and BUILD Conditions and the results are summarized as follows:

The following pages depict the tables that summarize the results of the signalized and unsignalized intersection analysis for each of the intersections in the study area

The following pages show the following conditions:

- Implementation Year (2025) NO BUILD Conditions (AM Peak and PM Peak Hours)
- Implementation Year (2025) BUILD Conditions (AM Peak and PM Peak Hours)

Following are the results summary tables for the implementation year (2025) analysis:

Synchro Results Summary Sheet

1: W. Frntg Rd & Mountain Rd.

2025 Conditions

Mountain Rd.

I-25 W Frntg Rd

Signalized

1: W. Frntg Rd & Mountain Rd. 2025 Conditions	EB (Mountain Rd.)			WB (Mountain Rd.)			SB (I-25 W Frntg Rd)		
	L	T	R	L	T	R	L	T	R
Existing Lane Geometry	0	2>	0	1	1	0	0	<3>	0
AM Peak Hour									
2025 NO BUILD Conditions Volumes	0	101	76	0	133	0	269	1,640	318
V/C Ratio	0.00	0.18		0.00	0.46	0.00	0.72	0.72	0.73
Level-of-Service		B			C		B	B	B
Control Delay (Seconds)		18.2			20.0		11.3	11.6	11.9
Intersection LOS	B - 12.3								
95th Percentile Queue (veh)	0.0	0.9	0.0	0.0	2.4	0.0	7.7	7.2	7.6
2025 BUILD Conditions Volumes	0	104	78	0	136	0	269	1,640	332
V/C Ratio	0.00	0.19		0.00	0.47	0.00	0.72	0.72	0.74
Level-of-Service		B			C		B	B	B
Control Delay (Seconds)		18.2			20.1		11.5	11.7	12.1
Intersection LOS	B - 12.5								
95th Percentile Queue (veh)	0.0	0.9	0.0	0.0	2.5	0.0	7.8	7.3	7.7
PM Peak Hour									
2025 NO BUILD Conditions Volumes	0	314	149	4	72	0	24	732	161
V/C Ratio	0.00	0.55		0.02	0.24	0.00	0.30	0.30	0.30
Level-of-Service		B		C	B		A	A	A
Control Delay (Seconds)		20.0		21.1	18.5		5.8	5.9	5.9
Intersection LOS	B - 10.0								
95th Percentile Queue (veh)	0.0	2.9	0.0	0.1	1.3	0.0	2.0	1.9	1.9
2025 BUILD Conditions Volumes	0	323	153	4	74	0	24	732	169
V/C Ratio	0.00	0.57		0.02	0.25	0.00	0.30	0.30	0.30
Level-of-Service		C		C	B		A	A	A
Control Delay (Seconds)		20.1		21.2	18.6		5.9	5.9	6.0
Intersection LOS	B - 10.1								
95th Percentile Queue (veh)	0.0	3.0	0.0	0.1	1.3	0.0	2.1	1.9	1.9

Synchro Results Summary Sheet

2: W. Frntg Rd & Lomas Blvd.

2025 Conditions

Lomas Blvd.

I-25 W Frntg Rd

Signalized

2: W. Frntg Rd & Lomas Blvd. 2025 Conditions	EB (Lomas Blvd.)			WB (Lomas Blvd.)			SB (I-25 W Frntg Rd)		
	L	T	R	L	T	R	L	T	R
Existing Lane Geometry	0	3>	0	1	3	0	1	<2>	1
AM Peak Hour									
2025 NO BUILD Conditions Volumes	0	836	141	88	961	0	756	261	470
V/C Ratio	0.00	0.54		0.34	0.47	0.00	0.46	0.45	0.40
Level-of-Service		C		C	C		B	B	B
Control Delay (Seconds)		33.0		25.1	25.2		18.4	18.7	18.2
Intersection LOS	C - 24.1								
95th Percentile Queue (veh)	0.0	10.4	0.0	2.8	10.4	0.0	9.8	10.0	7.8
2025 BUILD Conditions Volumes	0	837	141	88	965	0	756	261	470
V/C Ratio	0.00	0.54		0.34	0.48	0.00	0.46	0.45	0.40
Level-of-Service		C		C	C		B	B	B
Control Delay (Seconds)		33.1		25.1	25.3		18.4	18.7	18.1
Intersection LOS	C - 24.1								
95th Percentile Queue (veh)	0.0	10.4	0.0	2.8	10.4	0.0	9.8	10.0	7.8
PM Peak Hour									
2025 NO BUILD Conditions Volumes	0	945	217	209	997	0	318	330	189
V/C Ratio	0.00	0.37		0.50	0.32	0.00	0.41	0.53	0.27
Level-of-Service		B		B	B		D	D	C
Control Delay (Seconds)		18.9		13.9	11.2		36.5	37.4	34.1
Intersection LOS	C - 21.4								
95th Percentile Queue (veh)	0.0	9.3	0.0	4.7	7.5	0.0	8.9	11.4	5.3
2025 BUILD Conditions Volumes	0	948	218	209	999	0	321	331	189
V/C Ratio	0.00	0.37		0.50	0.32	0.00	0.42	0.53	0.27
Level-of-Service		B		B	B		D	D	C
Control Delay (Seconds)		18.9		13.9	11.3		36.6	37.4	34.1
Intersection LOS	C - 21.4								
95th Percentile Queue (veh)	0.0	9.3	0.0	4.7	7.5	0.0	8.9	11.4	5.3

Synchro Results Summary Sheet

3: Woodward Pl. & Lomas Blvd.

2025 Conditions

Lomas Blvd.

Woodward Pl.

Unsignalized

3: Woodward Pl. & Lomas Blvd. 2025 Conditions	EB (Lomas Blvd.)			WB (Lomas Blvd.)			NB (Woodward Pl.)			SB (Woodward Pl.)		
	L	T	R	L	T	R	L	T	R	L	T	R
Existing Lane Geometry	1	3	>	1	3	1	<	1	>	1	1	1
AM Peak Hour												
2025 NO BUILD Conditions Volumes	56	913	12	36	1,182	127	1	1	1	52	1	32
V/C Ratio	0.11			0.09				0.02		0.21	0.01	0.04
Level-of-Service	B			B				C		C	D	B
Control Delay (Seconds)	12.5			14.3				23.8		23.8	27.4	10.2
Intersection LOS	TWSC											
95th Percentile Queue (veh)	0.3			0.3				0.0		0.8	0.0	0.1
2025 BUILD Conditions Volumes	59	913	12	36	1,182	133	1	1	1	54	1	33
V/C Ratio	0.11			0.09				0.02		0.23	0.01	0.05
Level-of-Service	B			B				C		C	D	B
Control Delay (Seconds)	12.6			14.3				24.0		24.3	27.7	10.2
Intersection LOS	TWSC											
95th Percentile Queue (veh)	0.4			0.3				0.1		0.8	0.0	0.1
PM Peak Hour												
2025 NO BUILD Conditions Volumes	24	1,182	4	8	1,142	56	1	1	16	28	1	56
V/C Ratio	0.04			0.03				0.06		0.10	0.01	0.08
Level-of-Service	B			C				C		C	D	B
Control Delay (Seconds)	11.0			16.7				17.0		19.1	27.1	10.3
Intersection LOS	TWSC											
95th Percentile Queue (veh)	0.1			0.1				0.2		0.3	0.0	0.2
2025 BUILD Conditions Volumes	26	1,182	4	8	1,142	58	1	1	16	32	1	59
V/C Ratio	0.04			0.03				0.06		0.10	0.01	0.08
Level-of-Service	B			C				C		C	D	B
Control Delay (Seconds)	11.0			16.7				17.1		19.4	27.3	10.4
Intersection LOS	TWSC											
95th Percentile Queue (veh)	0.1			0.1				0.2		0.4	0.0	0.3

Synchro Results Summary Sheet

4: Woodward Pl. & Mountain Rd.

2025 Conditions

Mountain Rd.

Woodward Pl.

Unsignalized

4: Woodward Pl. & Mountain Rd. 2025 Conditions	EB (Mountain Rd.)			WB (Mountain Rd.)			NB (Woodward Pl.)		
	L	T	R	L	T	R	L	T	R
Existing Lane Geometry		1>	0	1	1		1		1
AM Peak Hour									
2025 NO BUILD Conditions Volumes		177	48	101	486		44		52
V/C Ratio				0.08			0.15		0.06
Level-of-Service				A			C		A
Control Delay (Seconds)				7.9			19.7		9.6
Intersection LOS					TWSC				
95th Percentile Queue (veh)				0.2			0.5		0.2
2025 BUILD Conditions Volumes		179	48	118	486		45		52
V/C Ratio				0.09			0.17		0.06
Level-of-Service				A			C		A
Control Delay (Seconds)				8.0			20.9		9.6
Intersection LOS					TWSC				
95th Percentile Queue (veh)				0.3			0.7		0.2
PM Peak Hour									
2025 NO BUILD Conditions Volumes		117	4	24	354		68		96
V/C Ratio				0.02			0.14		0.10
Level-of-Service				A			B		A
Control Delay (Seconds)				7.5			13.2		9.3
Intersection LOS					TWSC				
95th Percentile Queue (veh)				0.1			0.5		0.3
2025 BUILD Conditions Volumes		118	4	33	354		70		97
V/C Ratio				0.02			0.14		0.10
Level-of-Service				A			B		A
Control Delay (Seconds)				7.5			13.6		9.3
Intersection LOS					TWSC				
95th Percentile Queue (veh)				0.1			0.5		0.3

Synchro Results Summary Sheet

5: Mountain Rd. & W. Drvwy

2025 Conditions

Mountain Rd.

AHS W. Drvwy

Unsignalized

5: Mountain Rd. & W. Drvwy 2025 Conditions	EB (Mountain Rd.)			WB (Mountain Rd.)			SB (AHS W. Drvwy)		
	L	T	R	L	T	R	L	T	R
Existing Lane Geometry	1	1			1>	0	1>		0
AM Peak Hour									
2025 NO BUILD Conditions Volumes	76	193			233	205	109		109
V/C Ratio	0.07						0.44		
Level-of-Service	A						C		
Control Delay (Seconds)	8.5						17.7		
Intersection LOS	TWSC								
95th Percentile Queue (veh)	0.2						2.2		
2025 BUILD Conditions Volumes	76	195			234	205	109		109
V/C Ratio	0.07						0.44		
Level-of-Service	A						C		
Control Delay (Seconds)	8.5						17.8		
Intersection LOS	TWSC								
95th Percentile Queue (veh)	0.2						2.2		
PM Peak Hour									
2025 NO BUILD Conditions Volumes	20	133			233	44	201		185
V/C Ratio	0.02						0.59		
Level-of-Service	A						C		
Control Delay (Seconds)	7.9						18.0		
Intersection LOS	TWSC								
95th Percentile Queue (veh)	0.0						3.8		
2025 BUILD Conditions Volumes	20	134			235	44	201		185
V/C Ratio	0.02						0.59		
Level-of-Service	A						C		
Control Delay (Seconds)	7.9						18.1		
Intersection LOS	TWSC								
95th Percentile Queue (veh)	0.0						3.9		

Synchro Results Summary Sheet

6: Mountain Rd. & Cntr Drvwy

2025 Conditions

Mountain Rd.

Cntr AHS Drvwy

Driveway "B"

Unsignalized

6: Mountain Rd. & Cntr Drvwy 2025 Conditions	EB (Mountain Rd.)			WB (Mountain Rd.)			NB (Driveway "B:")			SB (Cntr AHS Drvwy)		
	L	T	R	L	T	R	L	T	R	L	T	R
Existing Lane Geometry	1	1>	0	0	1>	0	0	0	1	0	<1>	0
AM Peak Hour												
2025 NO BUILD Conditions Volumes	1	229	0	0	567	1	0	0	0	2	0	2
V/C Ratio	0.00										0.01	
Level-of-Service	A								A		B	
Control Delay (Seconds)	8.6								0.0		13.0	
Intersection LOS	TWSC											
95th Percentile Queue (veh)	0.0								0.0		0.0	
2025 BUILD Conditions Volumes	1	229	2	0	584	1	0	0	4	2	0	2
V/C Ratio	0.00								0.01		0.01	
Level-of-Service	A								A		B	
Control Delay (Seconds)	8.7								9.5		13.1	
Intersection LOS	TWSC											
95th Percentile Queue (veh)	0.0								0.0		0.0	
PM Peak Hour												
2025 NO BUILD Conditions Volumes	1	362	0	0	281	1	0	0	0	4	0	4
V/C Ratio	0.00										0.01	
Level-of-Service	A								A		B	
Control Delay (Seconds)	7.8								0.0		11.2	
Intersection LOS	TWSC											
95th Percentile Queue (veh)	0.0										0.0	
2025 BUILD Conditions Volumes	1	363	1	0	290	0	0	0	12	4	0	4
V/C Ratio	0.00								0.02		0.01	
Level-of-Service	A								B		B	
Control Delay (Seconds)	7.8								10.4		11.3	
Intersection LOS	TWSC											
95th Percentile Queue (veh)	0.0								0.1		0.0	

Synchro Results Summary Sheet

7: Mountain Rd. & E. Drvwy

2025 Conditions

Mountain Rd.

AHS E Drvwy

Unsignalized

7: Mountain Rd. & E. Drvwy 2025 Conditions	EB (Mountain Rd.)			WB (Mountain Rd.)			SB (AHS E Drvwy)		
	L	T	R	L	T	R	L	T	R
Existing Lane Geometry	1	1			1>	0	1>		0
AM Peak Hour									
2025 NO BUILD Conditions Volumes	80	169			511	197	80		60
V/C Ratio	0.09						0.42		
Level-of-Service	A						C		
Control Delay (Seconds)	9.5						23.6		
Intersection LOS TWSC									
95th Percentile Queue (veh)	0.3						2.0		
2025 BUILD Conditions Volumes	80	174			528	197	80		60
V/C Ratio	0.10						0.44		
Level-of-Service	A						C		
Control Delay (Seconds)	9.5						24.5		
Intersection LOS TWSC									
95th Percentile Queue (veh)	0.3						2.1		
PM Peak Hour									
2025 NO BUILD Conditions Volumes	28	326			233	40	137		117
V/C Ratio	0.02						0.47		
Level-of-Service	A						C		
Control Delay (Seconds)	7.9						17.3		
Intersection LOS TWSC									
95th Percentile Queue (veh)	0.1						2.5		
2025 BUILD Conditions Volumes	28	339			242	40	137		117
V/C Ratio	0.02						0.48		
Level-of-Service	A						C		
Control Delay (Seconds)	7.9						17.8		
Intersection LOS TWSC									
95th Percentile Queue (veh)	0.1						2.6		

Synchro Results Summary Sheet

8: Woodward Pl. & Embassy Drvwy

2025 Conditions

Embassy Drvwy

Woodward Pl

Unsignalized

8: Woodward Pl. & Embassy Drvwy 2025 Conditions	EB (Embassy Drvwy)			WB (Embassy Drvwy)			NB (Woodward Pl)			SB (Woodward Pl)		
	L	T	R	L	T	R	L	T	R	L	T	R
Existing Lane Geometry	0	<1>	0	0	<1>	0	1	2>	0	1	2>	0
AM Peak Hour												
2025 NO BUILD Conditions Volumes	12	0	8	8	0	8	28	68	12	44	40	16
V/C Ratio		0.03			0.02		0.02			0.03		
Level-of-Service		A			A		A			A		
Control Delay (Seconds)		9.7			9.6		7.4			7.5		
Intersection LOS	TWSC											
95th Percentile Queue (veh)		0.1			0.1		0.1			0.1		
2025 BUILD Conditions Volumes	12	0	8	11	0	8	28	76	12	61	40	16
V/C Ratio		0.03			0.03		0.02			0.04		
Level-of-Service		A			B		A			A		
Control Delay (Seconds)		10.0			10.1		7.4			7.5		
Intersection LOS	TWSC											
95th Percentile Queue (veh)		0.1			0.1		0.1			0.1		
PM Peak Hour												
2025 NO BUILD Conditions Volumes	48	0	8	20	0	56	0	84	4	4	20	4
V/C Ratio		0.06			0.08					0.00		
Level-of-Service		A			A		A			A		
Control Delay (Seconds)		9.4			9.0		0.0			7.4		
Intersection LOS	TWSC											
95th Percentile Queue (veh)		0.2			0.3		0.0			0.0		
2025 BUILD Conditions Volumes	48	0	8	27	0	71	0	88	4	13	20	4
V/C Ratio		0.07			0.10					0.01		
Level-of-Service		A			A		A			A		
Control Delay (Seconds)		9.6			9.2		0.0			7.4		
Intersection LOS	TWSC											
95th Percentile Queue (veh)		0.2			0.3		0.0			0.0		

Synchro Results Summary Sheet

8: Woodward Pl. & Embassy Drvwy

2025 Conditions

Embassy Drvwy

Woodward Pl

Unsignalized

8: Woodward Pl. & Embassy Drvwy 2025 Conditions	EB (Embassy Drvwy)			WB (Embassy Drvwy)			NB (Woodward Pl)			SB (Woodward Pl)		
	L	T	R	L	T	R	L	T	R	L	T	R
Existing Lane Geometry	0	<1>	0	0	<1>	0	1	2>	0	1	2>	0
AM Peak Hour												
2025 NO BUILD Conditions Volumes	12	0	8	8	0	8	28	68	12	44	40	16
V/C Ratio		0.03			0.02		0.02			0.03		
Level-of-Service		A			A		A			A		
Control Delay (Seconds)		9.7			9.6		7.4			7.5		
Intersection LOS	TWSC											
95th Percentile Queue (veh)		0.1			0.1		0.1			0.1		
2025 BUILD Conditions Volumes	12	0	8	11	0	8	28	76	12	61	40	16
V/C Ratio		0.03			0.03		0.02			0.04		
Level-of-Service		A			B		A			A		
Control Delay (Seconds)		10.0			10.1		7.4			7.5		
Intersection LOS	TWSC											
95th Percentile Queue (veh)		0.1			0.1		0.1			0.1		
PM Peak Hour												
2025 NO BUILD Conditions Volumes	48	0	8	20	0	56	0	84	4	4	20	4
V/C Ratio		0.06			0.08					0.00		
Level-of-Service		A			A		A			A		
Control Delay (Seconds)		9.4			9.0		0.0			7.4		
Intersection LOS	TWSC											
95th Percentile Queue (veh)		0.2			0.3		0.0			0.0		
2025 BUILD Conditions Volumes	48	0	8	27	0	71	0	88	4	13	20	4
V/C Ratio		0.07			0.10					0.01		
Level-of-Service		A			A		A			A		
Control Delay (Seconds)		9.6			9.2		0.0			7.4		
Intersection LOS	TWSC											
95th Percentile Queue (veh)		0.2			0.3		0.0			0.0		

Synchro Results Summary Sheet

9: Woodward Pl. & Driveway "A"

2025 Conditions

Driveway "A"

Woodward Pl.

Unsignalized

9: Woodward Pl. & Driveway "A" 2025 Conditions	WB (Driveway "A")			NB (Woodward Pl.)			SB (Woodward Pl.)		
	L	T	R	L	T	R	L	T	R
Existing Lane Geometry	0		1		2>	0	0	2	
AM Peak Hour									
2025 NO BUILD Conditions Volumes	0		0		96	0	0	149	
V/C Ratio									
Level-of-Service			A						
Control Delay (Seconds)			0.0						
Intersection LOS	TWSC								
95th Percentile Queue (veh)			0.0						
2025 BUILD Conditions Volumes	0		1		96	8	0	149	
V/C Ratio			0.00						
Level-of-Service			A						
Control Delay (Seconds)			8.6						
Intersection LOS	TWSC								
95th Percentile Queue (veh)			0.0						
PM Peak Hour									
2025 NO BUILD Conditions Volumes	0		0		164	0	0	28	
V/C Ratio									
Level-of-Service			A						
Control Delay (Seconds)			0.0						
Intersection LOS	TWSC								
95th Percentile Queue (veh)									
2025 BUILD Conditions Volumes	0		3		164	4	0	28	
V/C Ratio			0.00						
Level-of-Service			A						
Control Delay (Seconds)			8.8						
Intersection LOS	TWSC								
95th Percentile Queue (veh)			0.0						

Discussion of Implementation Year Analysis

Comparison of the analysis results of the intersections in the study area (preceding) reveal three things:

- 1) The operation of all intersections in the study area were generally found to be acceptable.
- 2) The impact of the proposed Mountain Rd. Rehabilitation Facility has no significant adverse impact to the adjacent transportation system.

LEVEL-OF-SERVICE CRITERIA FOR SIGNALIZED INTERSECTIONS

<u>Average Delay</u> <u>(secs)</u>	<u>Level-of-Service</u>
≤ 10	A
> 10 and ≤ 20	B
> 20 and ≤ 35	C
> 35 and ≤ 55	D
> 55 and ≤ 80	E
> 80	F

LEVEL-OF-SERVICE CRITERIA FOR UNSIGNALIZED INTERSECTIONS

<u>Average Delay</u> <u>(secs)</u>	<u>Level-of-Service</u>
≤ 10	A
> 10 and ≤ 15	B
> 15 and ≤ 25	C
> 25 and ≤ 35	D
> 35 and ≤ 50	E
> 50	F

Generally speaking, a Level-of-Service D or better is an acceptable parameter for design purposes.

Impact Assessment

The proposed development will have minimal adverse impact on the adjacent transportation system. All the levels-of-service were determined to be acceptable for the overall intersections.

Access Design Specifications

The project should be access via three driveways:

- 1) The existing full access unsignalized driveway to the Embassy Suites (located on the east side of Woodward Pl. approximately 375 feet south of Mountain Rd.
- 2) Driveway "A" (right-in, right-out only) along the east side of Woodward Pl. approximately
- 3) Driveway "B" (right-in, right-out only) along the south side of Mountain Rd. approximately 250 feet east of Woodward Pl. (centerline to centerline).

Safety Analysis

The safety analysis was performed using the following methodology:

- 1) Crash data was collected from the New Mexico Department of Transportation's Safety Bureau (Records Division) for the study area along the corridor of Mountain Rd. except for the intersection of Mountain Rd. / I-25 W. Frontage Rd.
- 2) Crash data for the signalized intersection of Mountain Rd. / I-25 W. Frontage Rd. was furnished by the New Mexico Department of Transportation District 3 office. The crash data for this one intersection consisted of full individual police crash reports with detailed descriptions (and often diagrams) to explain the reasons and events that occurred during the crash to help determine cause of the crashes.
- 3) Crash data was reviewed and tabulated to categorize crashes by type of crash if known.

The crash data requested from the New Mexico Department of Transportation included the intersection Mountain Rd. / Edith Blvd., Mountain Rd. / Woodward Pl., and Mountain Rd. / I-25 W. Frontage Rd. (Locust St.). Following is a map of the safety analysis study area:



Crash data was collected for the years 2018 through 2022 for each of the following:

Corridor #1 – Mountain Rd. between Broadway Blvd. and Edith Blvd.

Intersection #1 – Mountain Rd. / Edith Blvd.

Corridor #2 – Mountain Rd. between Edith Blvd. and Woodward Pl.

Intersection #2 – Mountain Rd. / Woodward Pl.

Corridor #3 – Mountain Rd. between Woodward Pl. and the I-25 W. Frntg. Rd.

Intersection #3 – Mountain Rd. / I-25 W. Frntg. Rd.

The crash records showed that there were no crashes during the study period for Corridor #1 (Mountain Rd. between Broadway Blvd. and Edith Blvd.) and Corridor #3 (Mountain Rd. between Woodward Pl. and the I-25 W. Frntg. Rd.). There were only three crashes along Corridor #2 (Mountain Rd. between Edith Blvd. and Woodward Pl.) (2 in 2019 and 1 in 2022). All three crashes were classified as Property Damage Only with no injuries or fatalities.

Following are tables that summarize the crashes at each of the three intersections in the safety study area:

**Crash Table for Mountain Rd. / Edith Blvd.
2018 through 2022**

Intersection # 1 (Mountain Rd. / Edith Blvd.)

Type of Crash	Year					Total
	2018	2019	2020	2021	2022	
Unclassified	0	1	1	2	3	7

7

Note: 5 PDO Crashes + 2 Injury Crashes. No fatalities.

**Crash Table for Mountain Rd. / Woodward Pl.
2018 through 2022**

Intersection # 2 (Mountain Rd. / Woodward Pl.)

Type of Crash	Year								Total
	2015	2016	2017	2018	2019	2020	2021	2022	
Right-Angle	1	0	0	0	0	0	0	0	1
Fixed Object	1	1	0	0	0	0	0	0	2
Subtotal	2	1	0	0	0	0	0	0	3

Note that no crashes were reported in the crash database supplied by the NM DOT Safety Bureau, so the study period was extended back to 2015 to provide some data.

Intersection # 3 (Mountain Rd. / I-25 W. Frntg. Rd.)

Type of Crash	Year					Total
	2018	2019	2020	2021	2022	
Right-Angle (WB / SB)	7	2	2	6	3	20
Right-Angle (EB / SB)	2	3	1	2	2	10
Rear-end Collision	2	2	0	0	0	4
SB LT from Thru Lane	4	1	1	1	1	8
Improper Lane Change	1	0	0	0	2	3
Vehicle Lost Control	0	2	0	0	2	4
Subtotal	16	10	4	9	10	49

Note: One driver reported that they saw the light behind them turn green in their rear view mirror and proceeded forward.
Note: Two drivers reported that they mistakenly saw the green light on the East Frntg. Frntg. Rd.

Crash data from the three intersections and the three corridors between the intersection did not indicate any significant safety issues. Of the area studied, the crashes at Intersection # 3 (Mountain Rd. / I-25 W. Frontage Rd.) were the greatest in frequency, but the crash rate was calculated to be 0.83 crashes per million entering vehicles. Prior to this study period, the New Mexico Department of Transportation conducted their own safety analysis (about 2015) and took some measures to improved safety at the intersection of Mountain Rd. / I-25 W. Frontage Rd.

The following table tabulates the Crash Severity of crashes from January 1, 2018 through December 31, 2022 by year:

Intersection # 3 (Mountain Rd. / I-25 W. Frntg. Rd.)

Crash Severity	Year					Total
	2018	2019	2020	2021	2022	
Fatality	1	0	0	0	0	1
Suspected Serious Injury	3	0	0	0	0	3
Suspected Minor Injury	1	1	0	0	1	3
Possible Injury	1	3	0	7	3	14
Property Damage Only	10	6	4	2	6	28
Subtotal	16	10	4	9	10	49

Based on the crash reports collected for the intersection of Mountain Rd. / I-25 W. Frontage Rd., this study makes the following recommendations:

- 1) Construct new yellow backplates on all signal heads at the intersection to enhance visibility.
- 2) Construct new laneage signs on the mastarm facing southbound traffic on the frontage road.
- 3) Mask the signal indicators at the east frontage road so as not to be visible from the west frontage road.

Additionally, the following table summarizes the causes of crashes including “Disregard Signal,” which includes crash report where both drivers report that they had a green light:

Intersection # 3 (Mountain Rd. / I-25 W. Frntg. Rd.)

Cause of Crash	Year					Total
	2018	2019	2020	2021	2022	
SB LT from Thru Lane	4	1	1	1	2	9
Disregard Signal*	9	6	3	7	5	30
Improper Lane Change	1	0	0	0	1	2
Rear-End Collision	1	1	0	0	0	2
Other	1	2	0	1	2	6
Subtotal	16	10	4	9	10	49

The graphical representation of the preceding table follows:

- NOTE: Orange part of bar – SB LT from Thru Lane
 Red part of bar – Disregard Signal*
 Green part of bar – Improper Lane Change
 Blue part of bar – Rear-end Collision
 Gray part of bar - Other

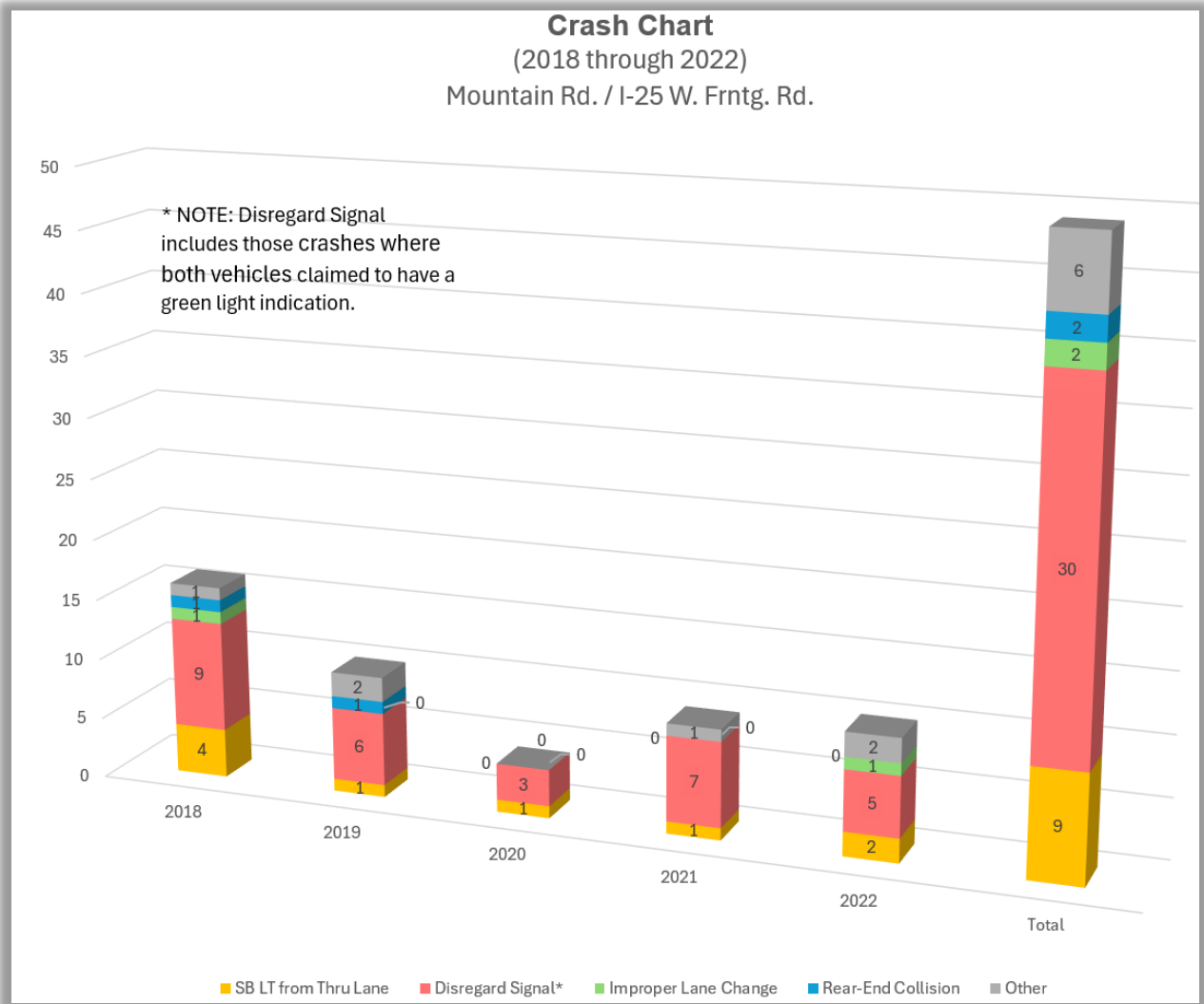

Summary of Deficiencies and Anticipated Impacts

This Study concludes based on the data and analysis presented that the proposed Mountain Rd. Rehabilitation Facility will have no significant adverse impact to the adjacent transportation system provided that the recommendations following and listed in the Executive Summary of this report are followed.

Recommendations

General – Construction of the Mountain Rd. Rehab Project and landscaping shall maintain adequate sight distances at access points and contiguous intersections.

Access – Project access should be comprised of two driveways on Woodward Pl. - one full access driveway (Embassy Suites Driveway) approximately 370 feet south of Mountain Rd. (centerline to centerline) shared with Embassy Suites Hotel, one right-in, right-out only driveway (Driveway “A”) on the east side of Woodward Pl. located approximately 180 feet south of Mountain Rd. (centerline to centerline), plus one right-in, right-out only driveway (Driveway “B”) on the south side of Mountain Rd. located approximately 250 feet east of Woodward Pl. (centerline to centerline). See Site Plan on Page A-3 in Appendix.

Mountain Rd. / I-25 W. Frontage Rd. – This safety component of this Study recommends three improvements to improve safety characteristics at Mountain Rd. / I-25 W. Frontage Rd.:

- 1) Construct new yellow backplates on all signal heads at the intersection to enhance visibility.
- 2) Construct new laneage signs on the mastarm facing southbound traffic on the frontage road.
- 5) Mask the signal indicators at the east frontage road so as not to be visible from the west frontage road.
- 6) The City of Albuquerque has reported that the southbound shoulder on the I-25 W. Frontage Rd. is currently being used as a right turn lane by some drivers. The City of Albuquerque will require the developer to construct new cross-hatching in the shoulder from the stop bar to 250 feet north of the stop bar.

It should be noted that the City of Albuquerque Traffic Operations has made plans to install detection equipment that detects oncoming speeding vehicles and adjusts signal timing appropriately.

Appendix

<u>SITE INFORMATION</u>	
Vicinity Map	A-1
Aerial Map	A-2
Site Plan	A-3
Portion - 2040 Long Range Roadway System Map (from MRMPO)	A-4
Portion – 2040 Long Range Bikeway System Map (from MRMPO)	A-5
Portion - 2022 Traffic Flow Map	A-6
<u>TRIP GENERATION</u>	
Trip Generation Worksheet	A-7
<u>TRIP DISTRIBUTION</u>	
Subarea Map - Trip Distribution Area	A-8
Trip Distribution Worksheets	A-9 thru A-11
Trip Distribution Map	A-12
Trip Distribution / Trip Assignments Map (% Entering) – Base Case	A-13
Trip Distribution / Trip Assignments Map (% Exiting) – Base Case	A-14
Blank Page	A-15 thru A-18
<u>HISTORIC GROWTH RATE</u>	
Historic Growth Table	A-19
Historic Growth Trendline Charts	A-20
<u>IMPLEMENTATION YEAR TURNING MOVEMENT COUNTS</u>	
Summary Table of Intersection Counts – Base Case	A-21 thru A-23
Individual Intersection Turning Movement Counts Tables – Base Case	A-24 thru A-41
Blank Page	A-42 thru A-146
<u>IMPLEMENTATION YEAR (2025) INTERSECTION ANALYSES (BASE CASE)</u>	
Intersection #1 - Signalized Intersection Analyses (Mountain Rd. / I-25 W. Frntg. Rd..)	A-147 thru A-150
Intersection #2 - Signalized Intersection Analyses (Lomas Blvd. / I-25 W. Frntg. Rd.)	A-151 thru A-154
Intersection #3 - Unsignalized Intersection Analysis (Lomas Blvd. / Woodward Pl.)	A-155 thru A-158
Intersection #4 - Unsignalized Intersection Analyses (Mountain Rd. / Woodward Pl.)	A-159 thru A-162
Intersection #5 - Signalized Intersection Analyses (Mountain Rd. / AHS W. Driveway)	A-163 thru A-166
Intersection #6 - Unsignalized Intersection Analysis (Mountain Rd. / AHS Center Driveway)	A-167 thru A-170
Intersection #7 - Unsignalized Intersection Analyses (Mountain Rd. / AHS E. Driveway)	A-171 thru A-174
Intersection #8 - Signalized Intersection Analyses (Embassy Suites Drvwy / Woodward Pl.)	A-175 thru A-178
Intersection #9 - Unsignalized Intersection Analysis (Driveway “B” / Woodward Pl.)	A-179 thru A-182
<u>HORIZON YEAR (2035) INTERSECTION ANALYSES (BASE CASE)</u>	
Blank Page	A-183 thru A-218
<u>IMPLEMENTATION YEAR (2025) INTERSECTION ANALYSES (LTD. CASE)</u>	
Blank Page	A-219 thru A-254
<u>HORIZON YEAR (2035) INTERSECTION ANALYSES (LTD. CASE)</u>	
Blank Page	A-255 thru A-290
<u>IMPLEMENTATION YEAR (2025) INTERSECTION ANALYSES (NO ACCESS CASE)</u>	
Blank Page	A-291 thru A-322
<u>HORIZON YEAR (2035) INTERSECTION ANALYSES (NO ACCESS CASE)</u>	
Blank Page	A-323 thru A-354
<u>Miscellaneous Data</u>	
Traffic Signal Timing Sheets (from City of Albuquerque)	A-355 thru A-360
Traffic Count Data	A-361 thru A-368

Crash Data	A-369
TIS Scoping Letter	A-370 thru A-372

APPENDIX

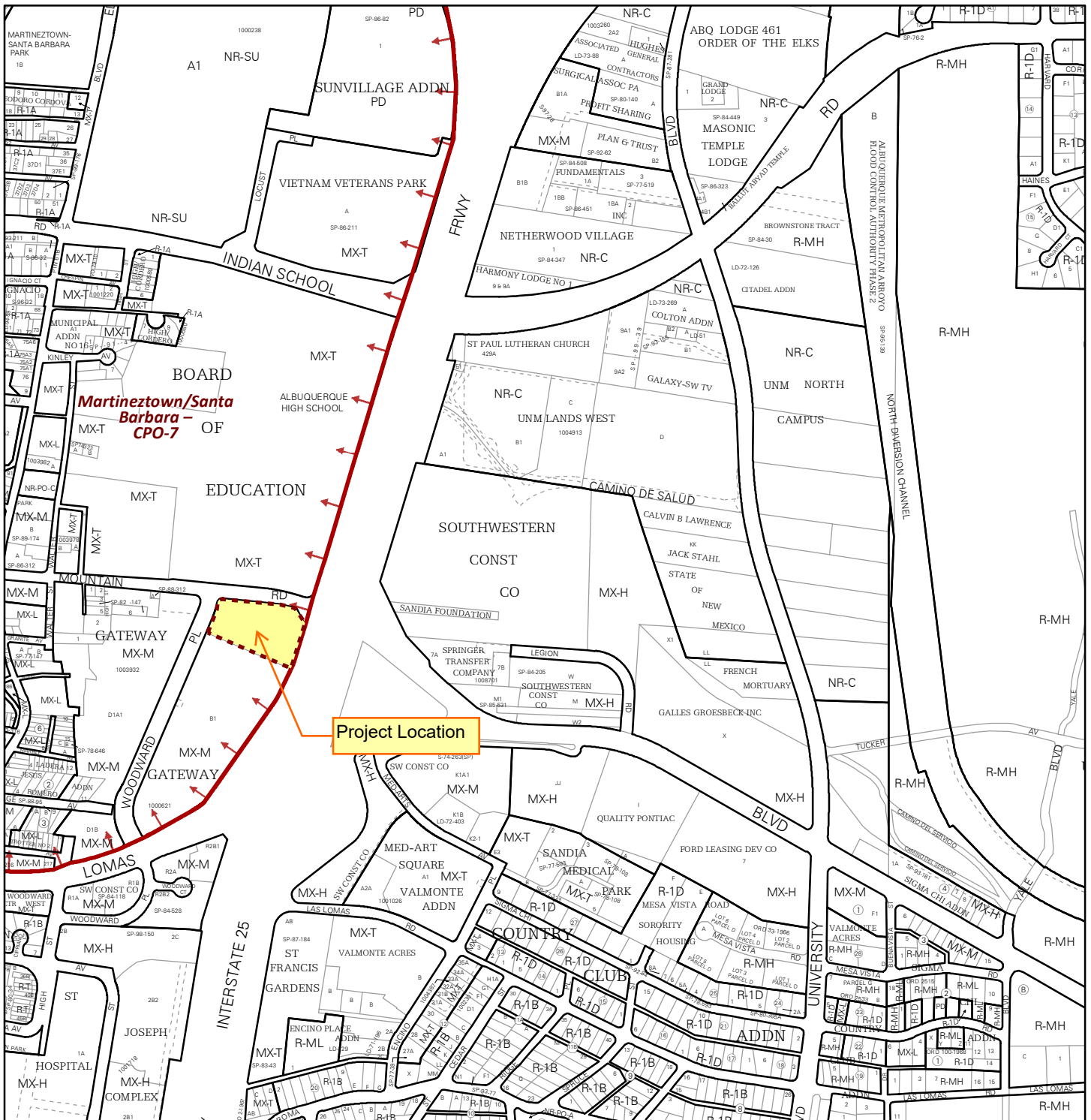

For more details about the Integrated Development Ordinance visit: <http://www.cabq.gov/planning/codes-policies-regulations/integrated-development-ordinance>

IDO Zone Atlas May 2018



IDO Zoning information as of May 17, 2018
The Zone Districts and Overlay Zones
are established by the
Integrated Development Ordinance (IDO).

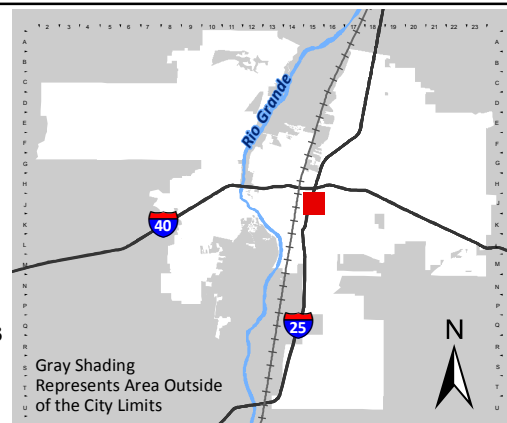

Gray Shading
Represents Area Outside
of the City Limits

Zone Atlas Page:
J-15-Z

- Easement
- Escarpment
- Petroglyph National Monument
- Areas Outside of City Limits
- Airport Protection Overlay (APO) Zone
- Character Protection Overlay (CPO) Zone
- Historic Protection Overlay (HPO) Zone
- View Protection Overlay (VPO) Zone

0 250 500 Feet

A-1



Early College Academy / Career Enrichment Center

Interstate 25

5

6

7

1

Odacrem Coffee Wholesales

Mountain Rd.

4

Martinez Painting & Body Shop

Rehab Center - Mountain and I-15

Rehab Center - Mountain and I-15

Michael J. Crossey, MD, PhD

8

Woodward Pl.

Embassy Suites by Hilton Albuquerque

2

Lomas Blvd.

3

New Heart Fitness and Health

Fresenius Kidney Care Home Dialysis - NM

Traffic Count Requirements:

AM Peak - 7:00 to 9:00 am

PM Peak - 3:30 to 5:30 pm (to pick up school peak)

Demand volumes for signalized intersections required.

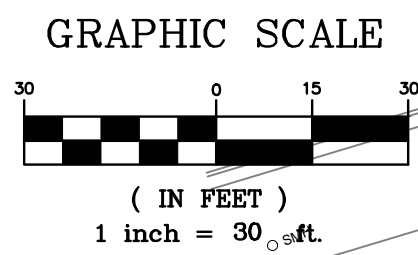
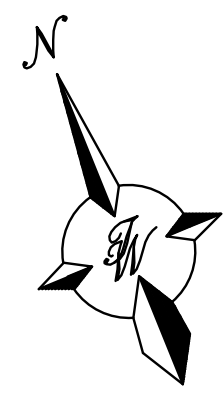

LANDSCAPING, FENCING AND SIGNING WILL NOT INTERFERE WITH THE CLEAR SIGHT REQUIREMENTS. THEREFORE SIGNS, WALLS, TREES AND SHRUBBERY BETWEEN 3' AND 8' TALL (AS MEASURED FROM THE GUTTER PAN) WILL NOT BE ACCEPTABLE IN THE CLEAR SIGHT TRIANGLE

SIGHT TRIANGLE (TYP)

ALL BROKEN OR CRACKED SIDEWALK AND CURB & GUTTER MUST BE REPLACED WITH SIDEWALK AND CURB & GUTTER PER COA STD DWG#2415 AND 2430

NOTE

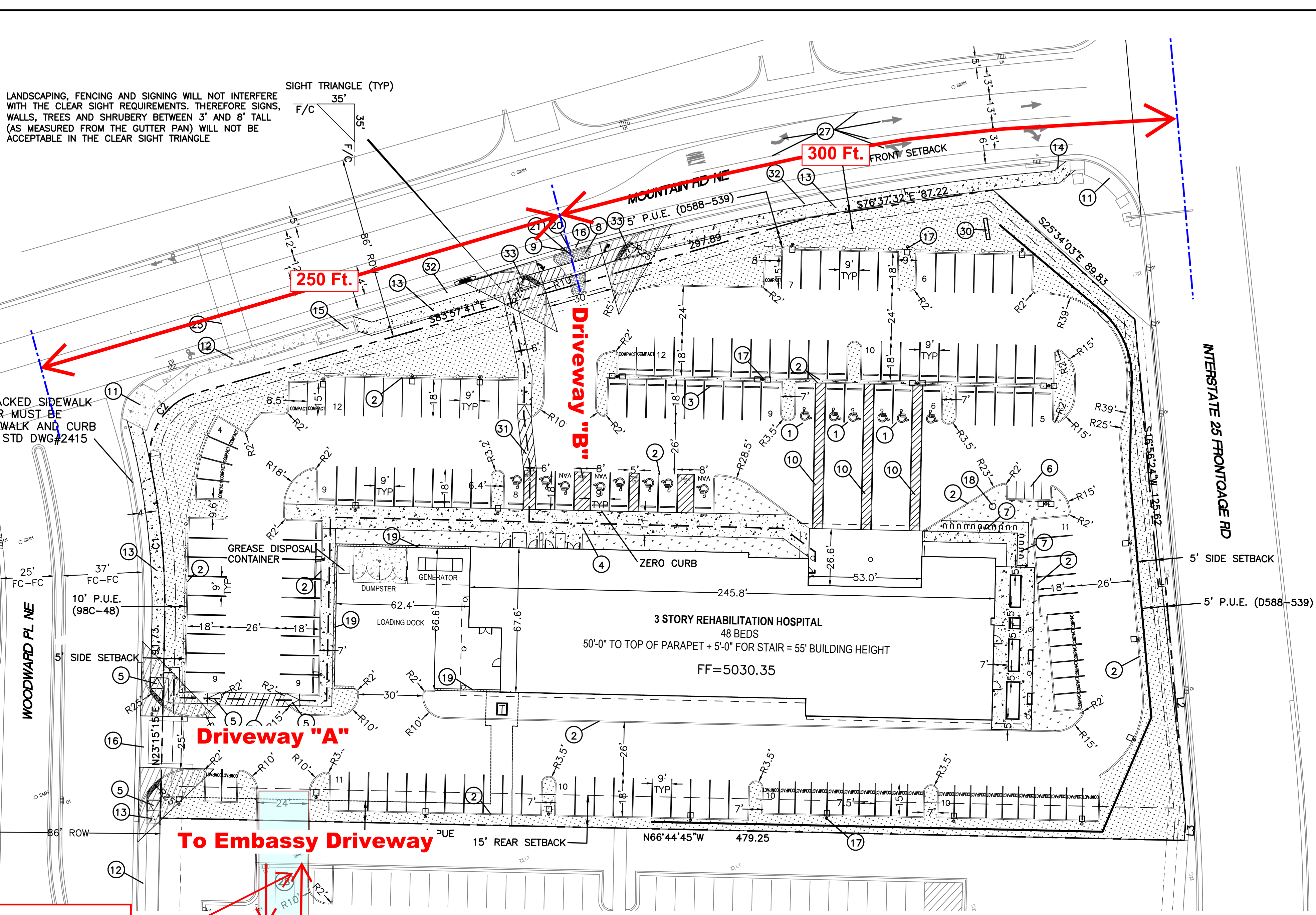

Cross-access easement to connect with Embassy Suites' North Driveway. (See easement / driveway below)

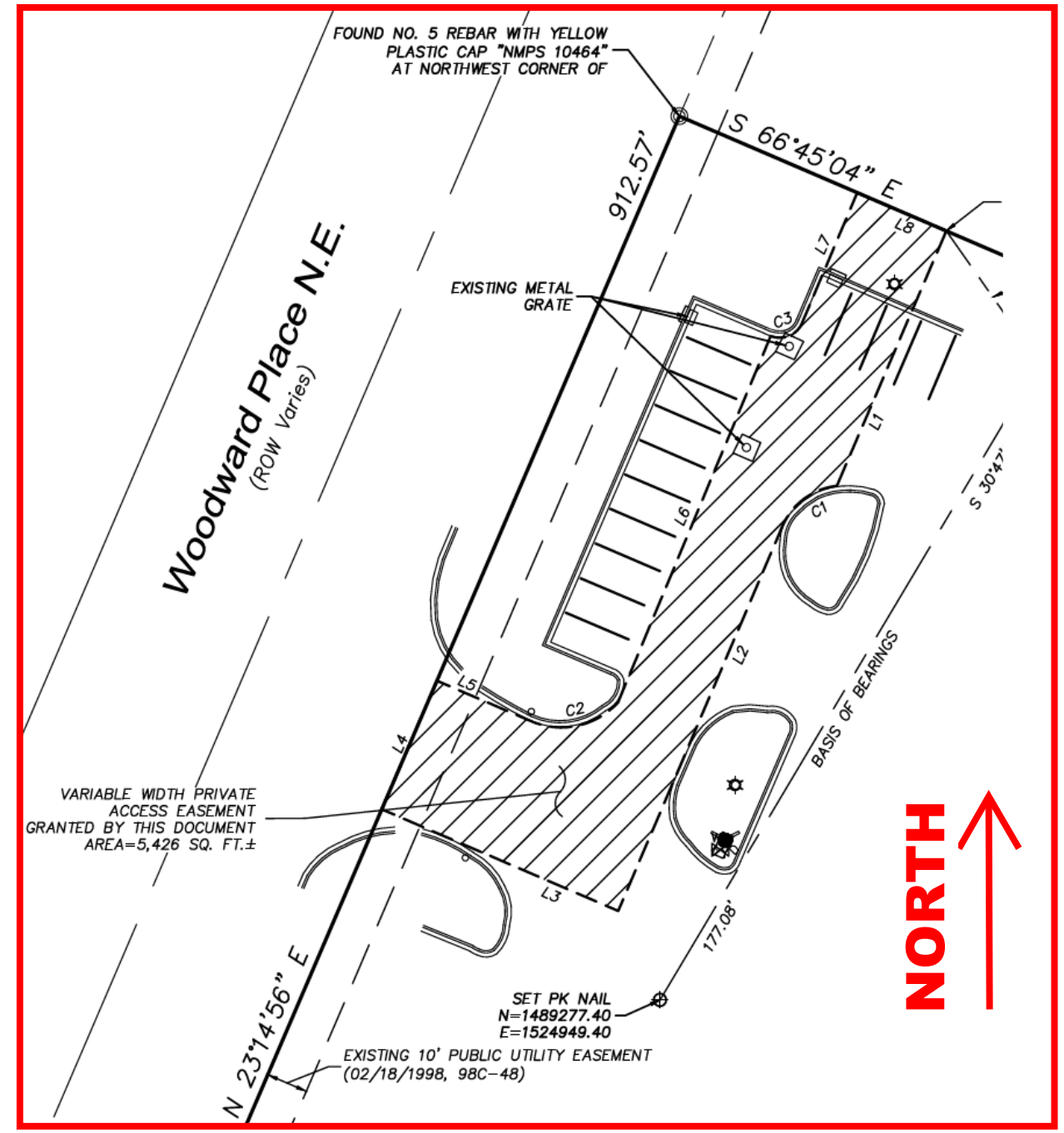

LEGEND

- CURB & GUTTER
- BOUNDARY LINE
- - - EASEMENT
- - - CENTERLINE
- - - RIGHT-OF-WAY
- ▭ BUILDING
- ▭ SIDEWALK
- - - EXISTING CURB & GUTTER
- - - EXISTING BOUNDARY LINE
- ▨ LANDSCAPING
- ▨ RETAINING WALL
- - - SETBACK LINE
- ▨ SCREEN WALL
- - - ADA ACCESS

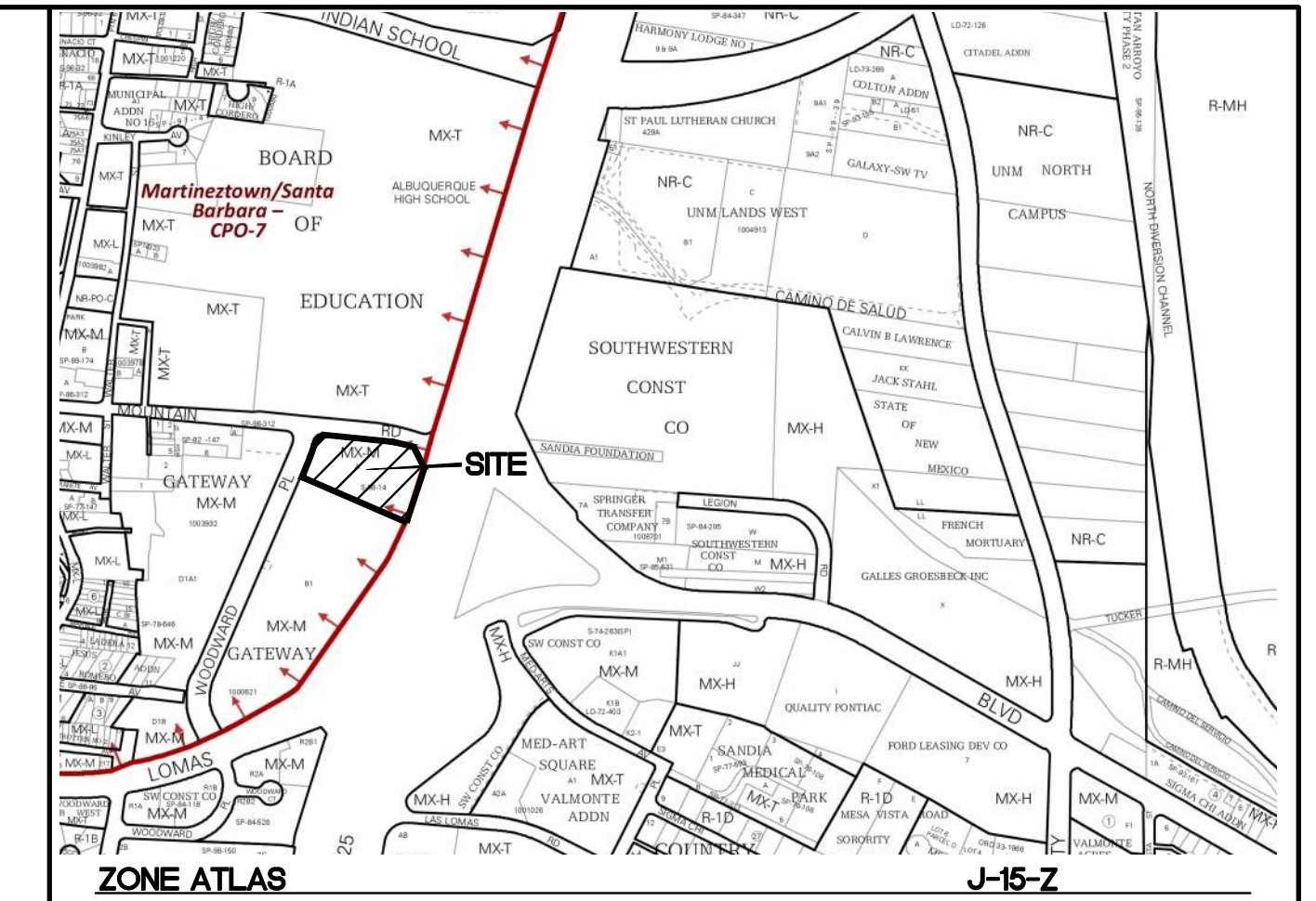

LEGAL DESCRIPTION:
TRACT LETTERED "A" OF THE PLAT OF GATEWAY SUBDIVISION

SITE DATA

PROPOSED USAGE	HOSPITAL
LOT AREA	119591 SF (2.7454 ACRES)
ZONING	MX-H
BUILDING AREA	55098 SF
BUILDING FOOTPRINT	16068 SF
BUILDING COVERAGE	13%
BUILDING SETBACK	
FRONT	5' MINIMUM
REAR	15' MINIMUM
SIDE	0' MINIMUM SOUTH SIDE, 5' MINIMUM NORTH SIDE
GFA 55098 SF/4 SPACE PER 1,000 =	220 SPACES
5-5(C)(5)(A) PARKING REDUCTION =	20%
5-5(C)(5)(C) PARKING REDUCTION =	10%
REDUCED PARKING REQUIRED =	154 SPACES
PARKING PROVIDED	146 SPACES
ACCESSIBLE PARKING REQUIRED	14 SPACES
ACCESSIBLE SPACES PROVIDED	14 SPACES (3 VAN ACCESSIBLE)
TOTAL	160 SPACES
BICYCLE SPACES REQUIRED	15
BICYCLE SPACES PROVIDED	15
MOTORCYCLE SPACES REQUIRED	5 SPACES
MOTORCYCLE SPACES PROVIDED	5 SPACES
LANDSCAPE REQUIRED	15536 SF
LANDSCAPE PROVIDED	34433 SF

PROJECT NUMBER: PR-2024-009765
APPLICATION NUMBER: SI-2024-00468

Is an Infrastructure List required? (X) Yes () No If Yes, then a set of approved DRC plans with a work order is required for any construction within Public Right-of-Way or for construction of public improvements.

DFT SITE DEVELOPMENT PLAN APPROVAL:

Traffic Engineer, Transportation Division	Date
ABCWUA	Date
Parks & Recreation Department	Date
Hydrology	Date
Code Enforcement	Date
* Environmental Health Department (conditional)	Date
Solid Waste Management	Date
Planning Department	Date

* Environmental Health, if necessary

	NOBIS REHAB HOSPITAL 1100 WOODWARD PL.	DRAWN BY pm
	SITE PLAN	DATE 7-14-25
7-14-25 RONALD R. BOHANNAN P.E. #7868	TIERRA WEST, LLC 5571 MIDWAY PARK PL NE ALBUQUERQUE, NEW MEXICO 87109 (505) 858-3100 www.tierrawestllc.com	DRAWING SHEET # SP-1 JOB # 2023123

LONG RANGE ROADWAY SYSTEM (LRRS)

Published April 2020.



LRRS Key

Roadway Function

- Interstate
- Regional Principal Arterial
- Community Principal Arterial
- Minor Arterial
- Major Collector
- Minor Collector

Future Roadways

- Potential Future Route
- - - Proposed Regional Arterial
- - - Proposed Community Arterial
- - - Proposed Minor Arterial
- - - Proposed Major Collector
- - - Proposed Minor Collector

Interchanges

- + Proposed Interchange
- + Proposed Grade-Separated Crossing
- + Proposed Interchange Beyond 2040

The **Long Range Roadway System (LRRS)** describes both existing and future (proposed) roadways in the Albuquerque Metropolitan Planning Area (AMPA). Roadways are classified by their character and their role in regional connectivity. This is in contrast to Functional Classification, which reflects current function and determines eligibility for federal funding.

Proposed facilities include projects beyond the 2040 timeframe. These roadways are included to help identify future need and important regional connections. This system should be viewed as an aspirational network.

Regional Principal Arterial roadways prioritize passenger vehicles and freight and are primarily for traveling longer distances across the region, so they are often located at the edges of activity centers.

Community Principal Arterial roadways may provide direct access to activity centers and strive to achieve a balance of modes of travel.

Minor Arterial roadways provide the connectivity of principal arterials, but prioritize slower moving traffic.

Major Collector roadways connect arterials and neighborhoods. They support short car trips while prioritizing bicyclists and pedestrians.

Minor Collector roadways provide additional connectivity between arterials and neighborhoods.

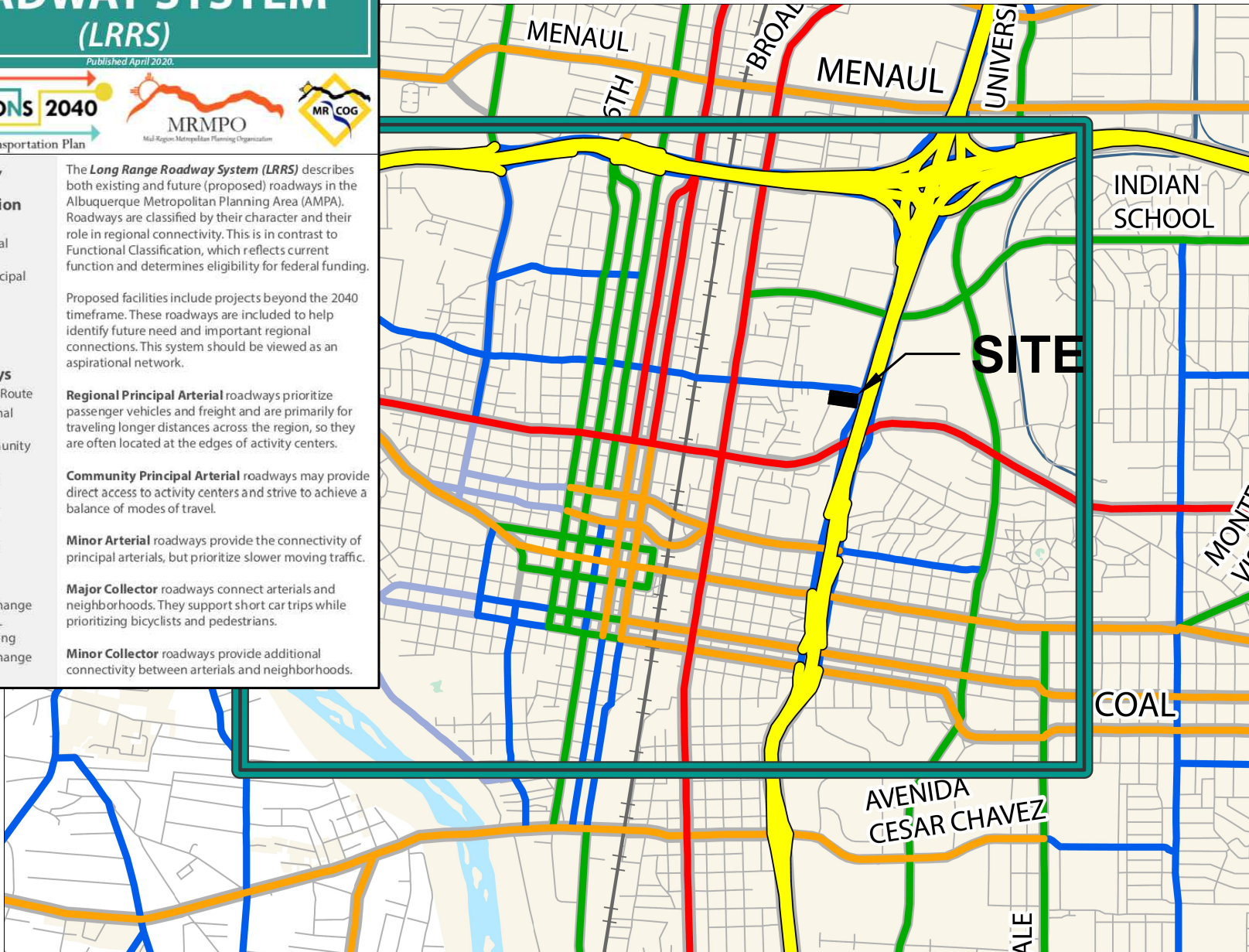

Portion of Futures 2040 Long Range Roadway System (from Mid-Region Council of Governments)

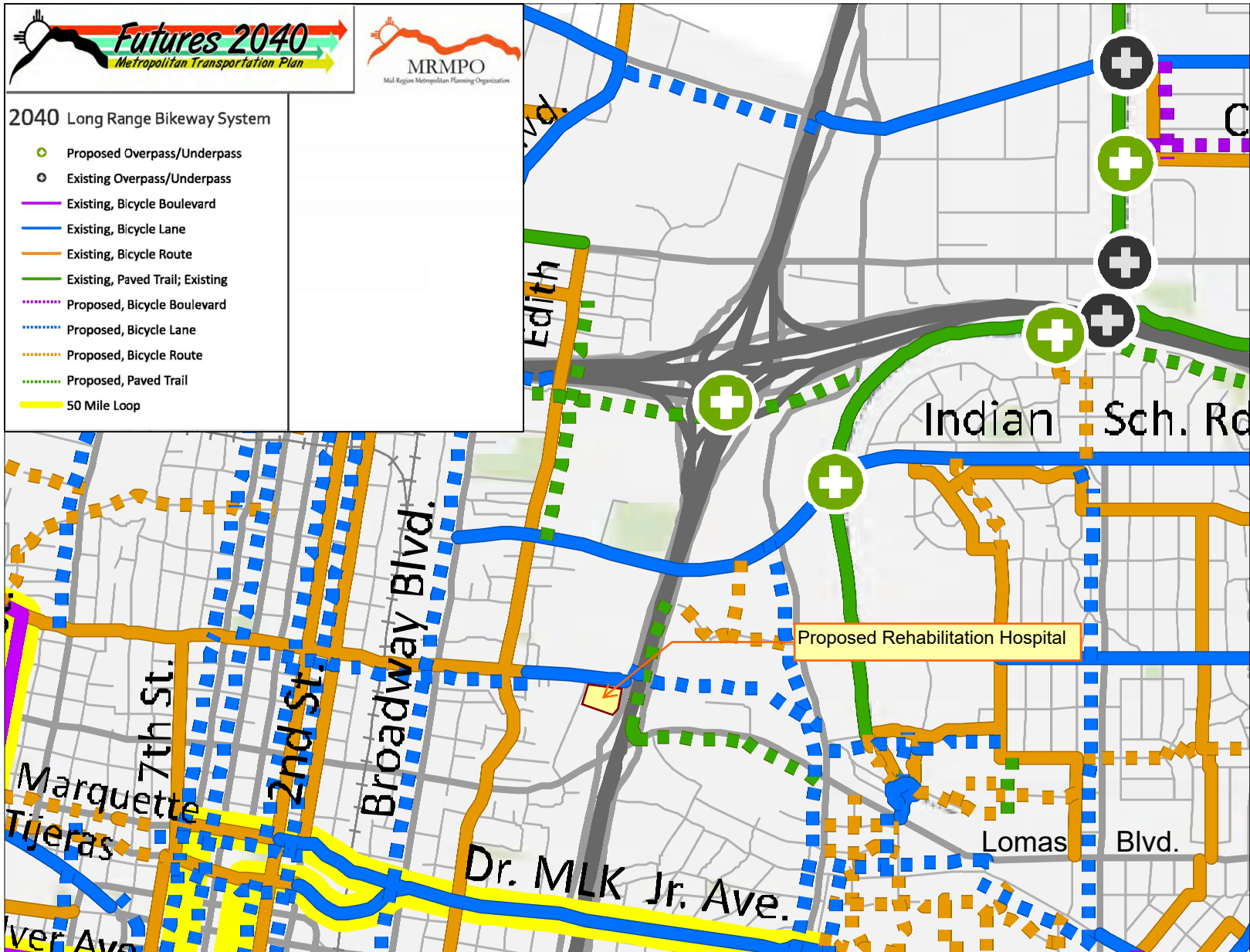

Portion of Futures 2040 Long Range Bikeway System
(from Mid-Region Council of Governments)

2022 Traffic Flows for the Greater Albuquerque Area

Map prepared by the Mid-Region Council of Governments (MRCOG) in cooperation with the New Mexico Department of Transportation, the local governments in the Albuquerque Metropolitan Planning Area, and the U.S. Department of Transportation. Federal Highway Administration. Map prepared August 2023.

Average Annual Weekday Traffic (AAWDT)



Standard Data
9500 Link Volume is based on traffic count data accepted by the NM Department of Transportation Traffic Monitoring System (TMS) as standard in accordance with the New Mexico State Traffic Monitoring Standard (NMSTMS).

Non-Standard Data
9500 Link Volume is based either on traffic count data not in compliance with the NMSTMS or on professional judgement. MRCOG recommends that nonstandard data be used with caution. Link volumes have been rounded to the nearest 100, with some count volumes being the average of two shorter segments.

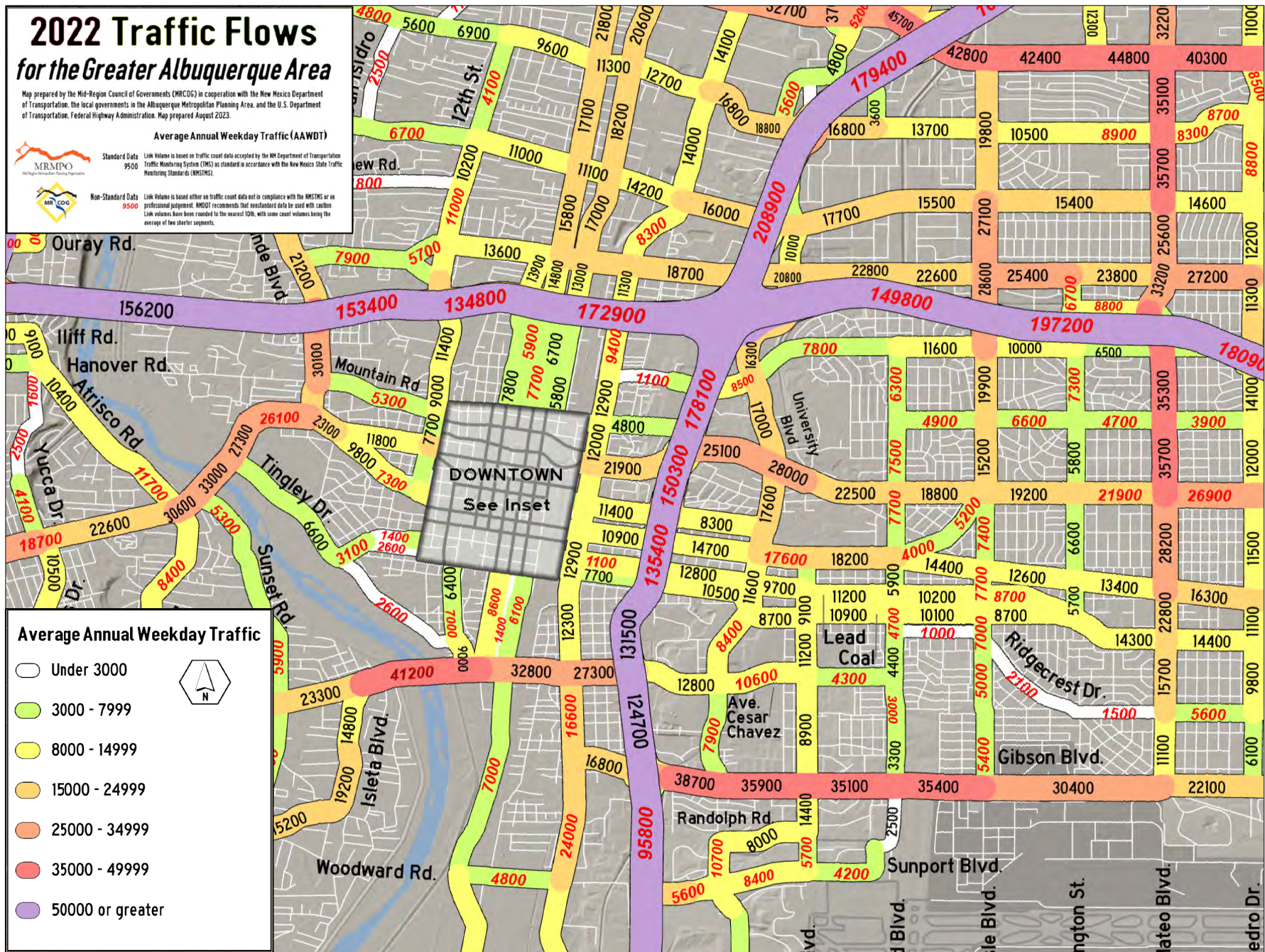

Average Annual Weekday Traffic

- Under 3000
- 3000 - 7999
- 8000 - 14999
- 15000 - 24999
- 25000 - 34999
- 35000 - 49999
- 50000 or greater



Rehabilitation Hospital (Mountain Rd. / I-25 W. Frontage Rd.) Trip Generation Data (ITE Trip Generation Manual - 11th Edition)

USE (ITE CODE)	24 HOUR TWO-WAY VOLUME	A. M. PEAK HOUR		P. M. PEAK HOUR		
		GROSS	ENTER	EXIT	ENTER	EXIT
Nursing Home (620)	64	432	27	8	15	22

Units
1,000 S.F.

ITE Trip Generation Equations:

Average Vehicle Trip Ends on a Weekday (24 HOUR TWO-WAY VOLUME)

$$T = 6.75 (X) + 0$$

50% Enter, 50% Exit

Average Vehicle Trip Ends on a Weekday, Peak Hour of Adjacent Street Traffic, One Hour Between 7am and 9am (A.M. PEAK HOUR)

$$T = 0.55 (X) + 0$$

77% Enter, 23% Exit

Average Vehicle Trip Ends on a Weekday, Peak Hour of Adjacent Street Traffic, One Hour Between 4pm and 6pm (P.M. PEAK HOUR)

$$T = 0.59 (X) + 0$$

41% Enter, 59% Exit

Comments:

Tract No.

Based on ITE Trip Generation Manual - 11th Edition

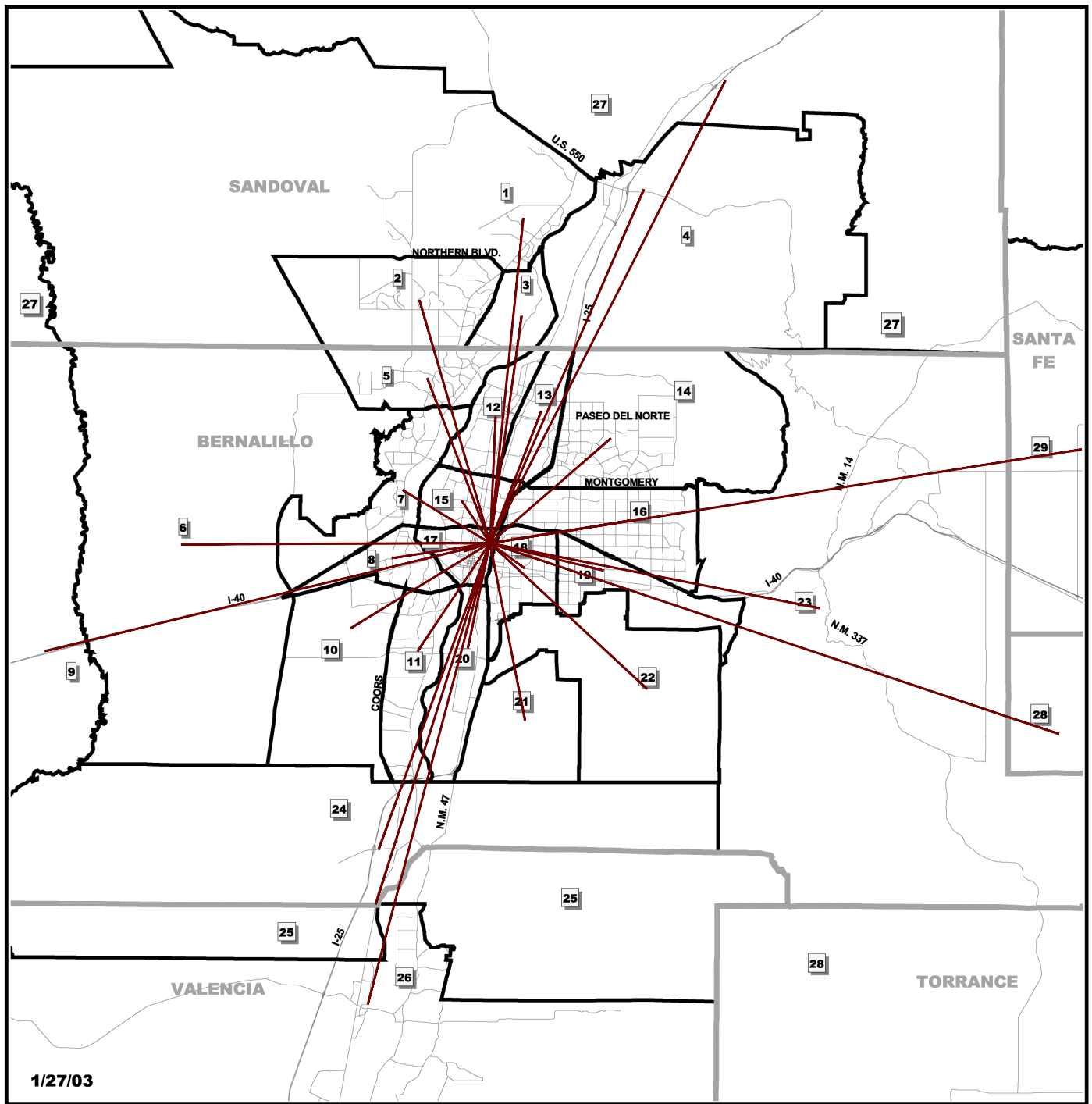

Figure 6

22 Subarea Identification Number

Subareas of the MRCOG Region

MR COG
Mid-Region Council of Governments
 317 Commercial NE, Suite 104
 Albuquerque, NM 87102
 505-247-1750

Subarea boundaries extend to county boundary where full extent of subarea not shown except for Subarea 29 which only includes southern Santa Fe County.

**Playa Del Sur
 (Miami Rd. / Camino Contento)
 Trip Distribution Subarea Map**

Trip Distribution Table

Mountain Rd. Rehabilitation Hospital (Mountain Rd. / I-25)

Sub Area Employment Data:

For determination of Trip Distribution for Proposed **Office / Warehouse Development Trips**

2016 and 2040 Data Taken from Mid-Region Council of Governments' 2040 Data Set
 Socioeconomic Forecasts by Data Analysis Subzones for the Mid-Region of New Mexico

Sub Area I.D.#	% Sub Area in Study	2016 Employment	2040 Employment	Interpolated Employment for the Year 2025	Employment in Study	Dist. (Mi.)	Employment / Distance	% Employment / Distance	(IN) I-25 NORTH			(LE) Lomas Blvd. East		
									% Utilizing	% Employment / Dist. Utilizing	Employment	% Utilizing	% Employment / Dist. Utilizing	Employment
1	100%	44,711	62,255	51,290	51,290	13.9	3,690	2.10%	100%	2.10%	3,690	0%	0.00%	0
2	100%	54,828	62,222	57,601	57,601	10.8	5,333	3.04%	100%	3.04%	5,333	0%	0.00%	0
3	100%	8,510	10,377	9,210	9,210	9.8	940	0.54%	100%	0.54%	940	0%	0.00%	0
4	100%	13,817	17,784	15,305	15,305	16.5	928	0.53%	100%	0.53%	928	0%	0.00%	0
5	100%	59,285	58,890	59,137	59,137	7.5	7,885	4.50%	100%	4.50%	7,885	0%	0.00%	0
6	100%	5,988	9,663	7,366	7,366	13.2	558	0.32%	50%	0.16%	279	0%	0.00%	0
7	100%	59,485	71,484	63,985	63,985	4.4	14,542	8.30%	50%	4.15%	7,271	0%	0.00%	0
8	100%	31,699	34,678	32,816	32,816	4.2	7,813	4.46%	50%	2.23%	3,907	0%	0.00%	0
9	100%	2,158	3,112	2,516	2,516	19.6	128	0.07%	70%	0.05%	90	0%	0.00%	0
10	100%	64,323	61,537	63,278	63,278	7	9,040	5.16%	0%	0.00%	0	0%	0.00%	0
11	100%	33,210	40,174	35,822	35,822	5.5	6,513	3.72%	0%	0.00%	0	0%	0.00%	0
12	100%	15,936	22,087	18,243	18,243	5.4	3,378	1.93%	100%	1.93%	3,378	0%	0.00%	0
13	100%	9,888	12,530	10,879	10,879	6	1,813	1.03%	100%	1.03%	1,813	0%	0.00%	0
14	100%	73,684	84,299	77,665	77,665	6.8	11,421	6.52%	100%	6.52%	11,421	0%	0.00%	0
15	100%	24,829	33,670	28,144	28,144	2.2	12,793	7.30%	50%	3.65%	6,396	0%	0.00%	0
16	100%	82,412	94,137	86,809	86,809	6	14,468	8.25%	100%	8.25%	14,468	0%	0.00%	0
17*	100%	22,270	37,540	27,996	27,996	1.2	23,330	13.31%	30%	3.99%	6,999	0%	0.00%	0
18	100%	41,643	56,762	47,313	47,313	1.8	26,285	14.99%	10%	1.50%	2,628	90%	13.49%	23,656
19	100%	65,540	81,066	71,362	71,362	5	14,272	8.14%	50%	4.07%	7,136	50%	4.07%	7,136
20	100%	9,636	10,794	10,070	10,070	4.6	2,189	1.25%	0%	0.00%	0	0%	0.00%	0
21	100%	559	17,783	7,018	7,018	7.7	911	0.52%	0%	0.00%	0	0%	0.00%	0
22	100%	3,511	3,820	3,627	3,627	9.1	399	0.23%	0%	0.00%	0	0%	0.00%	0
23	100%	19,163	27,184	22,171	22,171	14.4	1,540	0.88%	80%	0.70%	1,232	20%	0.18%	308
24	100%	2,531	3,352	2,839	2,839	13.9	204	0.12%	0%	0.00%	0	0%	0.00%	0
25	100%	863	1,161	975	975	16.2	60	0.03%	0%	0.00%	0	0%	0.00%	0
26	100%	56,155	59,697	57,483	57,483	20.4	2,818	1.61%	0%	0.00%	0	0%	0.00%	0
27	100%	19,926	24,499	21,641	21,641	22.2	975	0.56%	100%	0.56%	975	0%	0.00%	0
28	100%	15,662	18,407	16,691	16,691	25.6	652	0.37%	80%	0.30%	522	20%	0.07%	130
29	100%	10,397	11,564	10,835	10,835	25.6	423	0.24%	80%	0.19%	339	20%	0.05%	85
		852,619	1,032,528	920,085	920,085		175,302	100.00%		49.99%	87,630		17.86%	31,316
											49.99%			17.86%
											Use 50%			Use 18%

* - Subarea in which the site it located.

Trip Distribution Table

Mountain Rd. Rehabilitation Hospital (Mountain Rd. / I-25)

Sub Area Employment Data:

For determination of Trip Distribution for Proposed **Office / Warehouse Development Trips**

2016 and 2040 Data Taken from Mid-Region Council of Governments' 2040 Data Set
 Socioeconomic Forecasts by Data Analysis Subzones for the Mid-Region of New Mexico

Sub Area I.D.#	% Sub Area in Study	2016 Employment	2040 Employment	Interpolated Employment for the Year 2025	Employment in Study	Dist. (Mi.)	Employment / Distance	% Employment / Distance	(IS) I-25 South			(WS) Woodward Pl. South		
									% Utilizing	% Employment / Dist. Utilizing	Employment	% Utilizing	% Employment / Dist. Utilizing	Employment
1	100%	44,711	62,255	51,290	51,290	13.9	3,690	2.10%	0%	0.00%	0	0%	0.00%	0
2	100%	54,828	62,222	57,601	57,601	10.8	5,333	3.04%	0%	0.00%	0	0%	0.00%	0
3	100%	8,510	10,377	9,210	9,210	9.8	940	0.54%	0%	0.00%	0	0%	0.00%	0
4	100%	13,817	17,784	15,305	15,305	16.5	928	0.53%	0%	0.00%	0	0%	0.00%	0
5	100%	59,285	58,890	59,137	59,137	7.5	7,885	4.50%	0%	0.00%	0	0%	0.00%	0
6	100%	5,988	9,663	7,366	7,366	13.2	558	0.32%	0%	0.00%	0	0%	0.00%	0
7	100%	59,485	71,484	63,985	63,985	4.4	14,542	8.30%	0%	0.00%	0	0%	0.00%	0
8	100%	31,699	34,678	32,816	32,816	4.2	7,813	4.46%	0%	0.00%	0	0%	0.00%	0
9	100%	2,158	3,112	2,516	2,516	19.6	128	0.07%	0%	0.00%	0	0%	0.00%	0
10	100%	64,323	61,537	63,278	63,278	7	9,040	5.16%	70%	3.61%	6,328	0%	0.00%	0
11	100%	33,210	40,174	35,822	35,822	5.5	6,513	3.72%	80%	2.97%	5,210	0%	0.00%	0
12	100%	15,936	22,087	18,243	18,243	5.4	3,378	1.93%	0%	0.00%	0	0%	0.00%	0
13	100%	9,888	12,530	10,879	10,879	6	1,813	1.03%	0%	0.00%	0	0%	0.00%	0
14	100%	73,684	84,299	77,665	77,665	6.8	11,421	6.52%	0%	0.00%	0	0%	0.00%	0
15	100%	24,829	33,670	28,144	28,144	2.2	12,793	7.30%	0%	0.00%	0	0%	0.00%	0
16	100%	82,412	94,137	86,809	86,809	6	14,468	8.25%	0%	0.00%	0	0%	0.00%	0
17*	100%	22,270	37,540	27,996	27,996	1.2	23,330	13.31%	0%	0.00%	0	10%	1.33%	2,333
18	100%	41,643	56,762	47,313	47,313	1.8	26,285	14.99%	0%	0.00%	0	0%	0.00%	0
19	100%	65,540	81,066	71,362	71,362	5	14,272	8.14%	0%	0.00%	0	0%	0.00%	0
20	100%	9,636	10,794	10,070	10,070	4.6	2,189	1.25%	100%	1.25%	2,189	0%	0.00%	0
21	100%	559	17,783	7,018	7,018	7.7	911	0.52%	100%	0.52%	911	0%	0.00%	0
22	100%	3,511	3,820	3,627	3,627	9.1	399	0.23%	100%	0.23%	399	0%	0.00%	0
23	100%	19,163	27,184	22,171	22,171	14.4	1,540	0.88%	0%	0.00%	0	0%	0.00%	0
24	100%	2,531	3,352	2,839	2,839	13.9	204	0.12%	100%	0.12%	204	0%	0.00%	0
25	100%	863	1,161	975	975	16.2	60	0.03%	100%	0.03%	60	0%	0.00%	0
26	100%	56,155	59,697	57,483	57,483	20.4	2,818	1.61%	100%	1.61%	2,818	0%	0.00%	0
27	100%	19,926	24,499	21,641	21,641	22.2	975	0.56%	0%	0.00%	0	0%	0.00%	0
28	100%	15,662	18,407	16,691	16,691	25.6	652	0.37%	0%	0.00%	0	0%	0.00%	0
29	100%	10,397	11,564	10,835	10,835	25.6	423	0.24%	0%	0.00%	0	0%	0.00%	0
		852,619	1,032,528	920,085	920,085		175,302	100.00%		10.34%	18,120	1.33%		2,333
											10.34%			1.33%
											Use 10%			Use 1%

* - Subarea in which the site it located.

Trip Distribution Table

Mountain Rd. Rehabilitation Hospital (Mountain Rd. / I-25)

Sub Area Employment Data:

For determination of Trip Distribution for Proposed **Office / Warehouse Development Trips**

2016 and 2040 Data Taken from Mid-Region Council of Governments' 2040 Data Set
 Socioeconomic Forecasts by Data Analysis Subzones for the Mid-Region of New Mexico

Sub Area I.D.#	% Sub Area in Study	2016 Employment	2040 Employment	Interpolated Employment for the Year 2025	Employment in Study	Dist. (Mi.)	Employment / Distance	% Employment / Distance	(LW) Lomas Blvd. West			(MW) Mountain Rd. West		
									% Utilizing	% Employment / Dist. Utilizing	Employment	% Utilizing	% Employment / Dist. Utilizing	Employment
1	100%	44,711	62,255	51,290	51,290	13.9	3,690	2.10%	0%	0.00%	0	0%	0.00%	0
2	100%	54,828	62,222	57,601	57,601	10.8	5,333	3.04%	0%	0.00%	0	0%	0.00%	0
3	100%	8,510	10,377	9,210	9,210	9.8	940	0.54%	0%	0.00%	0	0%	0.00%	0
4	100%	13,817	17,784	15,305	15,305	16.5	928	0.53%	0%	0.00%	0	0%	0.00%	0
5	100%	59,285	58,890	59,137	59,137	7.5	7,885	4.50%	0%	0.00%	0	0%	0.00%	0
6	100%	5,988	9,663	7,366	7,366	13.2	558	0.32%	30%	0.10%	167	20%	0.06%	112
7	100%	59,485	71,484	63,985	63,985	4.4	14,542	8.30%	30%	2.49%	4,363	20%	1.66%	2,908
8	100%	31,699	34,678	32,816	32,816	4.2	7,813	4.46%	30%	1.34%	2,344	20%	0.89%	1,563
9	100%	2,158	3,112	2,516	2,516	19.6	128	0.07%	20%	0.01%	26	10%	0.01%	13
10	100%	64,323	61,537	63,278	63,278	7	9,040	5.16%	20%	1.03%	1,808	10%	0.52%	904
11	100%	33,210	40,174	35,822	35,822	5.5	6,513	3.72%	20%	0.74%	1,303	0%	0.00%	0
12	100%	15,936	22,087	18,243	18,243	5.4	3,378	1.93%	0%	0.00%	0	0%	0.00%	0
13	100%	9,888	12,530	10,879	10,879	6	1,813	1.03%	0%	0.00%	0	0%	0.00%	0
14	100%	73,684	84,299	77,665	77,665	6.8	11,421	6.52%	0%	0.00%	0	0%	0.00%	0
15	100%	24,829	33,670	28,144	28,144	2.2	12,793	7.30%	30%	2.19%	3,838	20%	1.46%	2,559
16	100%	82,412	94,137	86,809	86,809	6	14,468	8.25%	0%	0.00%	0	0%	0.00%	0
17*	100%	22,270	37,540	27,996	27,996	1.2	23,330	13.31%	30%	3.99%	6,999	30%	3.99%	6,999
18	100%	41,643	56,762	47,313	47,313	1.8	26,285	14.99%	0%	0.00%	0	0%	0.00%	0
19	100%	65,540	81,066	71,362	71,362	5	14,272	8.14%	0%	0.00%	0	0%	0.00%	0
20	100%	9,636	10,794	10,070	10,070	4.6	2,189	1.25%	0%	0.00%	0	0%	0.00%	0
21	100%	559	17,783	7,018	7,018	7.7	911	0.52%	0%	0.00%	0	0%	0.00%	0
22	100%	3,511	3,820	3,627	3,627	9.1	399	0.23%	0%	0.00%	0	0%	0.00%	0
23	100%	19,163	27,184	22,171	22,171	14.4	1,540	0.88%	0%	0.00%	0	0%	0.00%	0
24	100%	2,531	3,352	2,839	2,839	13.9	204	0.12%	0%	0.00%	0	0%	0.00%	0
25	100%	863	1,161	975	975	16.2	60	0.03%	0%	0.00%	0	0%	0.00%	0
26	100%	56,155	59,697	57,483	57,483	20.4	2,818	1.61%	0%	0.00%	0	0%	0.00%	0
27	100%	19,926	24,499	21,641	21,641	22.2	975	0.56%	0%	0.00%	0	0%	0.00%	0
28	100%	15,662	18,407	16,691	16,691	25.6	652	0.37%	0%	0.00%	0	0%	0.00%	0
29	100%	10,397	11,564	10,835	10,835	25.6	423	0.24%	0%	0.00%	0	0%	0.00%	0
		852,619	1,032,528	920,085	920,085		175,302	100.00%		11.89%	20,847	8.59%	15,057	
											11.89%		8.59%	
											Use 12%		Use 9%	

* - Subarea in which the site it located.

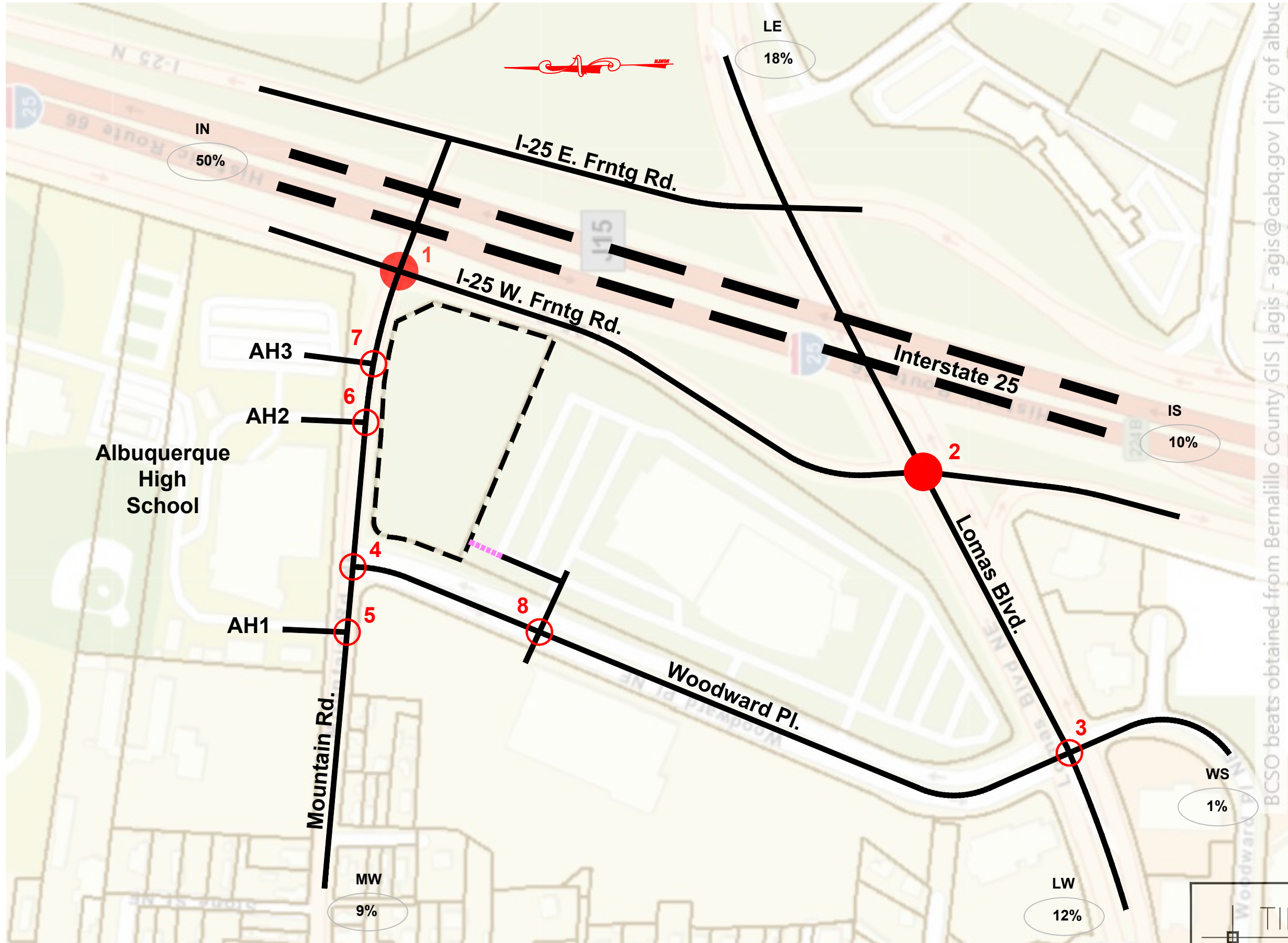

BCSO beats obtained from Bernalillo County GIS | agis - agis@cabq.gov | city of albuq

- SIGNALIZED INTERSECTION
- UNSIGNALIZED INTERSECTION

Mountain Rd. Rehabilitation Hospital
(Mountain Rd. / Woodward Pl.)
Trip Distribution Map
Medical Office

TIERRA WEST, LLC
5571 MIDWAY PARK PLACE NE
ALBUQUERQUE, NEW MEXICO 87109
(505)858-3100

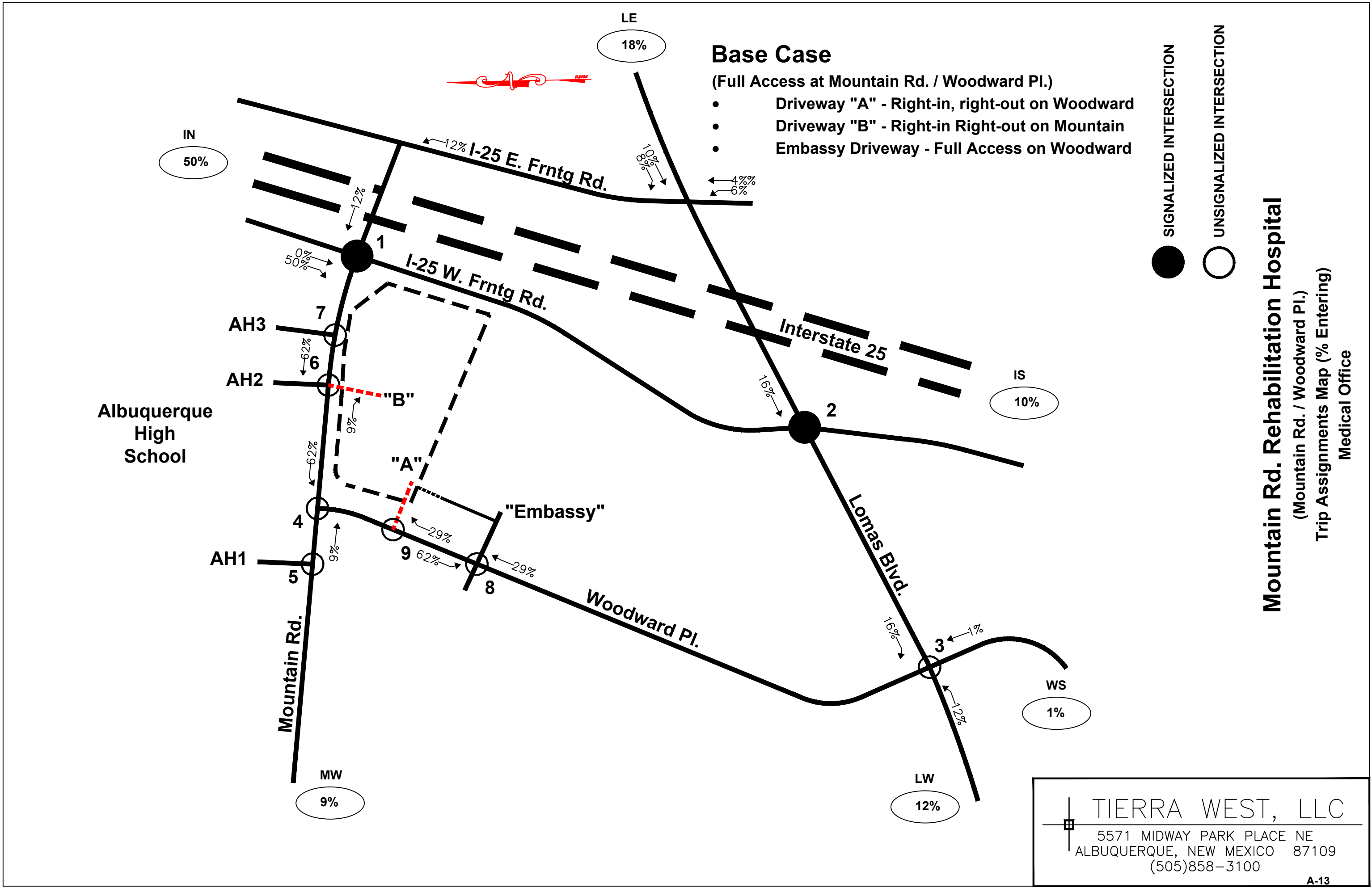

Base Case

(Full Access at Mountain Rd. / Woodward Pl.)

- Driveway "A" - Right-in, right-out on Woodward
- Driveway "B" - Right-in Right-out on Mountain
- Embassy Driveway - Full Access on Woodward

- SIGNALIZED INTERSECTION
- UNSIGNALIZED INTERSECTION

Mountain Rd. Rehabilitation Hospital

(Mountain Rd. / Woodward Pl.)

Trip Assignments Map (% Entering)
Medical Office

TIERRA WEST, LLC
 5571 MIDWAY PARK PLACE NE
 ALBUQUERQUE, NEW MEXICO 87109
 (505)858-3100

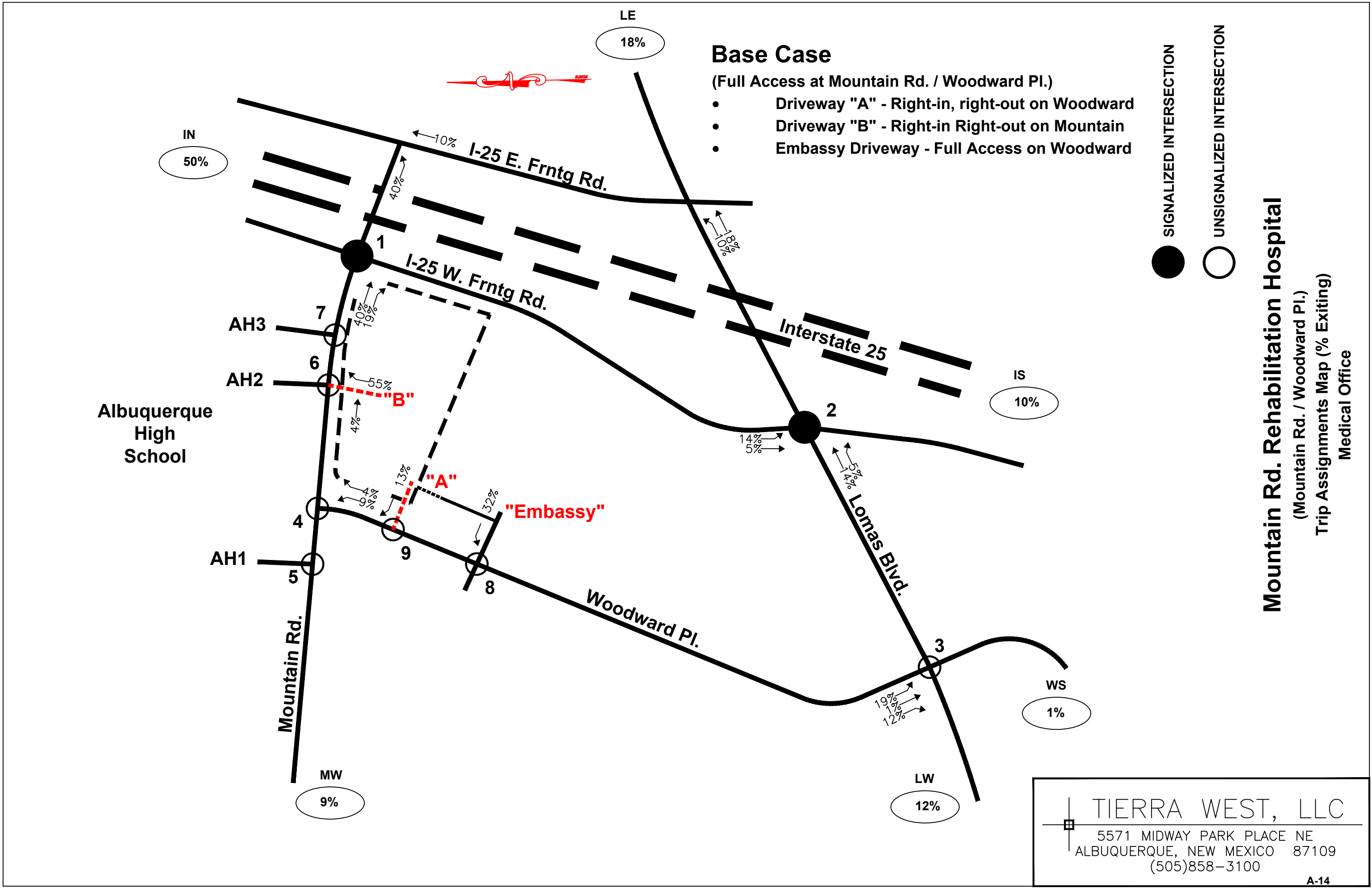

Base Case

(Full Access at Mountain Rd. / Woodward Pl.)

- Driveway "A" - Right-in, right-out on Woodward
- Driveway "B" - Right-in Right-out on Mountain
- Embassy Driveway - Full Access on Woodward

● SIGNALIZED INTERSECTION
○ UNSIGNALIZED INTERSECTION

Mountain Rd. Rehabilitation Hospital

(Mountain Rd. / Woodward Pl.)

Trip Assignments Map (% Exiting)

Medical Office

TIERRA WEST, LLC
 5571 MIDWAY PARK PLACE NE
 ALBUQUERQUE, NEW MEXICO 87109
 (505)858-3100

**Pages A-15 through A-18
(INTENTIONALLY LEFT BLANK)**

Historic Growth Data Table
Mountain Rd. Rehabilitation Hospital
(Mountain Rd. / Woodward Pl.)

Traffic Flows (AWDT) from Mid-Region Council of Governments

COG ID	Location			2013	2014	2015	2016	2017	2018	2019	2020	2021	2022
Intersection #1:	MOUNTAIN ROAD / PAN AM. WEST												
	Street:	From:	To:										
23977	MOUNTAIN ROAD	EAST OF BROADWAY	WEST OF PAN AMERICAN WI	5,935	5,876	5,077	5,229	5,397	6,048	5,858	3,978	4,942	4,838
23979	MOUNTAIN ROAD	EAST OF PAN AMERICAN WE	WEST OF PAN AMERICAN EA	2,755	3,984	3,878	3,994	4,122	3,472	3,363	2,284	2,838	2,881
22475	PAN AM. WEST	NORTH OF MOUNTAIN	SOUTH OF I-25 SBD OFF RAM	12,487	12,362	16,228	16,715	17,253	14,298	13,849	9,404	11,619	11,795
22478	PAN AM. WEST	NORTH OF LOMAS	SOUTH OF MOUNTAIN	10,829	10,721	11,530	11,876	12,258	12,266	11,881	8,067	10,682	10,844
Total Intersection Traffic Flows				32,006	32,943	36,713	37,814	39,030	36,084	34,951	23,733	30,081	30,358

Historic Traffic Flow Graph Intersection #1: Mountain Rd. / I-25 W. Frntg.

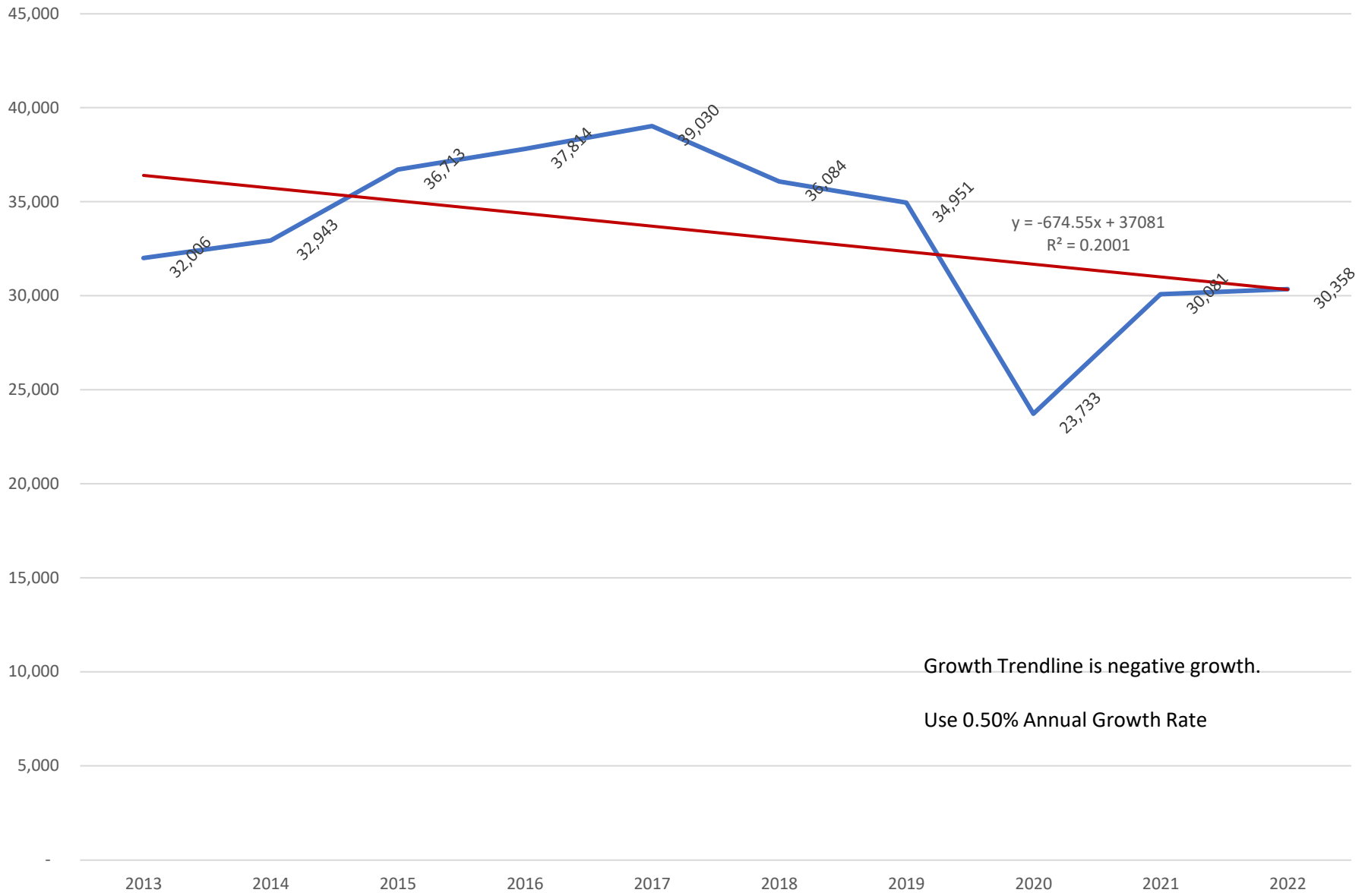

Growth Trendline is negative growth.

Use 0.50% Annual Growth Rate

Mountain Rd. Rehabilitation Hospital (Mountain Rd. / Woodward Pl.)

Projected Turning Movements SUMMARY
PROPOSED DEVELOPMENT (2025) - 100% Development
Base Case (Full Access at Mountain Rd. / Woodward Pl.)

INTERSECTION : Summary

Mountain Rd. / I-25 Frntg. Rd. 1.00 1.00 1.00 1.00 PHF

(1) 2.0% Truck

	Eastbound (Mountain Rd.)			Westbound (Mountain Rd.)			Northbound (I-25 Frntg. Rd.)			Southbound (I-25 Frntg. Rd.)		
	Left	Thru	Right	Left	Thru	Right	Left	Thru	Right	Left	Thru	Right
Existing (2024)	0	100	76	0	132	0	0	0	0	268	1,632	316
2025 (NO BUILD - A.M.)	0	101	76	0	133	0	0	0	0	269	1,640	318
2025 (BUILD - A.M.)	0	104	78	0	136	0	0	0	0	269	1,640	332

1.00 1.00 1.00 1.00 PHF

	Eastbound (Mountain Rd.)			Westbound (Mountain Rd.)			Northbound (I-25 Frntg. Rd.)			Southbound (I-25 Frntg. Rd.)		
	Left	Thru	Right	Left	Thru	Right	Left	Thru	Right	Left	Thru	Right
Existing (2024)	0	312	148	4	72	0	0	0	0	24	728	160
2025 (NO BUILD - P.M.)	0	314	149	4	72	0	0	0	0	24	732	161
2025 (BUILD - P.M.)	0	323	153	4	74	0	0	0	0	24	732	169

Lomas Blvd. / I-25 W. Frntg 1.00 1.00 1.00 1.00 PHF

(2) 2.0% Truck

	Eastbound (Lomas Blvd.)			Westbound (Lomas Blvd.)			Northbound (I-25 W. Frntg)			Southbound (I-25 W. Frntg)		
	Left	Thru	Right	Left	Thru	Right	Left	Thru	Right	Left	Thru	Right
Existing (2024)	0	832	140	88	956	0	0	0	0	752	260	468
2025 (NO BUILD - A.M.)	0	836	141	88	961	0	0	0	0	756	261	470
2025 (BUILD - A.M.)	0	837	141	88	965	0	0	0	0	757	261	470

1.00 1.00 1.00 1.00 PHF

	Eastbound (Lomas Blvd.)			Westbound (Lomas Blvd.)			Northbound (I-25 W. Frntg)			Southbound (I-25 W. Frntg)		
	Left	Thru	Right	Left	Thru	Right	Left	Thru	Right	Left	Thru	Right
Existing (2024)	0	940	216	208	992	0	0	0	0	316	328	188
2025 (NO BUILD - P.M.)	0	945	217	209	997	0	0	0	0	318	330	189
2025 (BUILD - P.M.)	0	948	218	209	999	0	0	0	0	321	331	189

Lomas Blvd. / Woodward Pl. 1.00 1.00 1.00 1.00 PHF

(3) 2.0% Truck

	Eastbound (Lomas Blvd.)			Westbound (Lomas Blvd.)			Northbound (Woodward Pl.)			Southbound (Woodward Pl.)		
	Left	Thru	Right	Left	Thru	Right	Left	Thru	Right	Left	Thru	Right
Existing (2024)	56	908	12	36	1,176	128	0	0	0	52	0	32
2025 (NO BUILD - A.M.)	56	913	12	36	1,182	129	0	0	0	52	0	32
2025 (BUILD - A.M.)	59	913	12	36	1,182	133	0	0	0	54	0	33

1.00 1.00 1.00 1.00 PHF

	Eastbound (Lomas Blvd.)			Westbound (Lomas Blvd.)			Northbound (Woodward Pl.)			Southbound (Woodward Pl.)		
	Left	Thru	Right	Left	Thru	Right	Left	Thru	Right	Left	Thru	Right
Existing (2024)	24	1,176	4	8	1,136	56	0	0	16	28	0	56
2025 (NO BUILD - P.M.)	24	1,182	4	8	1,142	56	0	0	16	28	0	56
2025 (BUILD - P.M.)	26	1,182	4	8	1,142	58	0	0	16	32	0	59

Mountain Rd. / Woodward Pl. 1.00 1.00 1.00 1.00 PHF

(4) 2.0% Truck

	Eastbound (Mountain Rd.)			Westbound (Mountain Rd.)			Northbound (Woodward Pl.)			Southbound (Woodward Pl.)		
	Left	Thru	Right	Left	Thru	Right	Left	Thru	Right	Left	Thru	Right
Existing (2024)	0	176	48	100	484	0	44	0	52	0	0	0
2025 (NO BUILD - A.M.)	0	177	48	101	486	0	44	0	52	0	0	0
2025 (BUILD - A.M.)	0	179	48	118	486	0	45	0	52	0	0	0

1.00 1.00 1.00 1.00 PHF

	Eastbound (Mountain Rd.)			Westbound (Mountain Rd.)			Northbound (Woodward Pl.)			Southbound (Woodward Pl.)		
	Left	Thru	Right	Left	Thru	Right	Left	Thru	Right	Left	Thru	Right
Existing (2024)	0	116	4	24	352	0	68	0	96	0	0	0
2025 (NO BUILD - P.M.)	0	117	4	24	354	0	68	0	96	0	0	0
2025 (BUILD - P.M.)	0	118	4	33	354	0	70	0	97	0	0	0

Mountain Rd. Rehabilitation Hospital (Mountain Rd. / Woodward Pl.)

Projected Turning Movements SUMMARY
PROPOSED DEVELOPMENT (2025) - 100% Development
Base Case (Full Access at Mountain Rd. / Woodward Pl.)

INTERSECTION : Summary

Mountain Rd. / AHS W. Driveway 1.00 1.00 1.00 1.00 PHF

(5)	Eastbound (Mountain Rd.)			Westbound (Mountain Rd.)			Northbound (AHS W. Driveway)			Southbound (AHS W. Driveway)		
	Left	Thru	Right	Left	Thru	Right	Left	Thru	Right	Left	Thru	Right
2.0% Truck												
Existing (2024)	76	192	0	0	232	204	0	0	0	108	0	108
2025 (NO BUILD - A.M.)	76	193	0	0	233	205	0	0	0	109	0	109
2025 (BUILD - A.M.)	76	195	0	0	234	205	0	0	0	109	0	109

	Eastbound (Mountain Rd.)			Westbound (Mountain Rd.)			Northbound (AHS W. Driveway)			Southbound (AHS W. Driveway)		
	Left	Thru	Right	Left	Thru	Right	Left	Thru	Right	Left	Thru	Right
Existing (2024)	20	132	0	0	232	44	0	0	0	200	0	184
2025 (NO BUILD - P.M.)	20	133	0	0	233	44	0	0	0	201	0	185
2025 (BUILD - P.M.)	20	134	0	0	235	44	0	0	0	201	0	185

Mountain Rd. / AHS Cntr Drvwy 1.00 1.00 1.00 1.00 PHF

(6)	Eastbound (Mountain Rd.)			Westbound (Mountain Rd.)			Northbound (AHS Cntr Drvwy)			Southbound (AHS Cntr Drvwy)		
	Left	Thru	Right	Left	Thru	Right	Left	Thru	Right	Left	Thru	Right
2.0% Truck												
Existing (2024)	0	228	0	0	564	0	0	0	0	2	0	2
2025 (NO BUILD - A.M.)	0	229	0	0	567	0	0	0	0	2	0	2
2025 (BUILD - A.M.)	0	229	2	0	584	0	0	0	4	2	0	2

	Eastbound (Mountain Rd.)			Westbound (Mountain Rd.)			Northbound (AHS Cntr Drvwy)			Southbound (AHS Cntr Drvwy)		
	Left	Thru	Right	Left	Thru	Right	Left	Thru	Right	Left	Thru	Right
Existing (2024)	0	360	0	0	280	0	0	0	0	4	0	4
2025 (NO BUILD - P.M.)	0	362	0	0	281	0	0	0	0	4	0	4
2025 (BUILD - P.M.)	0	363	1	0	290	0	0	0	12	4	0	4

Mountain Rd. / AHS E. Driveway 1.00 1.00 1.00 1.00 PHF

(7)	Eastbound (Mountain Rd.)			Westbound (Mountain Rd.)			Northbound (AHS E. Driveway)			Southbound (AHS E. Driveway)		
	Left	Thru	Right	Left	Thru	Right	Left	Thru	Right	Left	Thru	Right
2.0% Truck												
Existing (2024)	80	168	0	0	508	196	0	0	0	80	0	60
2025 (NO BUILD - A.M.)	80	169	0	0	511	197	0	0	0	80	0	60
2025 (BUILD - A.M.)	80	174	0	0	528	197	0	0	0	80	0	60

	Eastbound (Mountain Rd.)			Westbound (Mountain Rd.)			Northbound (AHS E. Driveway)			Southbound (AHS E. Driveway)		
	Left	Thru	Right	Left	Thru	Right	Left	Thru	Right	Left	Thru	Right
Existing (2024)	28	324	0	0	232	40	0	0	0	136	0	116
2025 (NO BUILD - P.M.)	28	326	0	0	233	40	0	0	0	137	0	117
2025 (BUILD - P.M.)	28	339	0	0	242	40	0	0	0	137	0	117

Embassy Drvwy / Woodward Pl. 1.00 1.00 1.00 1.00 PHF

(8)	Eastbound (Embassy Drvwy)			Westbound (Embassy Drvwy)			Northbound (Woodward Pl.)			Southbound (Woodward Pl.)		
	Left	Thru	Right	Left	Thru	Right	Left	Thru	Right	Left	Thru	Right
2.0% Truck												
Existing (2024)	12	0	8	8	0	8	28	68	12	44	40	16
2025 (NO BUILD - A.M.)	12	0	8	8	0	8	28	68	12	44	40	16
2025 (BUILD - A.M.)	12	0	8	11	0	8	28	76	12	61	40	16

	Eastbound (Embassy Drvwy)			Westbound (Embassy Drvwy)			Northbound (Woodward Pl.)			Southbound (Woodward Pl.)		
	Left	Thru	Right	Left	Thru	Right	Left	Thru	Right	Left	Thru	Right
Existing (2024)	48	0	8	20	0	56	0	84	4	4	20	4
2025 (NO BUILD - P.M.)	48	0	8	20	0	56	0	84	4	4	20	4
2025 (BUILD - P.M.)	48	0	8	27	0	56	0	88	4	13	20	4

Mountain Rd. Rehabilitation Hospital (Mountain Rd. / Woodward Pl.)

Projected Turning Movements SUMMARY
PROPOSED DEVELOPMENT (2025) - 100% Development
Base Case (Full Access at Mountain Rd. / Woodward Pl.)

INTERSECTION: Summary

Driveway "A" / Woodward Pl.		1.00			1.00			1.00			1.00			PHF
(9)	2.0% Truck	Eastbound (Driveway "A")			Westbound (Driveway "A")			Northbound (Woodward Pl.)			Southbound (Woodward Pl.)			
		Left	Thru	Right	Left	Thru	Right	Left	Thru	Right	Left	Thru	Right	
Existing (2024)		0	0	0	0	0	0	0	0	0	0	0	0	0
2025 (NO BUILD - A.M.)		0	0	0	0	0	0	0	96	0	0	0	149	0
2025 (BUILD - A.M.)		0	0	0	0	0	1	0	96	8	0	0	149	0
		1.00			1.00			1.00			1.00			PHF
Existing (2024)		Eastbound (Driveway "A")			Westbound (Driveway "A")			Northbound (Woodward Pl.)			Southbound (Woodward Pl.)			
		Left	Thru	Right	Left	Thru	Right	Left	Thru	Right	Left	Thru	Right	
2025 (NO BUILD - P.M.)		0	0	0	0	0	0	0	0	0	0	0	28	0
2025 (BUILD - P.M.)		0	0	0	0	0	3	0	164	4	0	0	28	0

Mountain Rd. Rehabilitation Hospital (Mountain Rd. / Woodward Pl.)

Projected Turning Movements Worksheet

Mountain Rd. / I-25 Frntg. Rd.

Base Case (Full Access at Mountain Rd. / Woodward Pl.)

INTERSECTION : E-W Street: **Mountain Rd.**
 N-S Street: **I-25 Frntg. Rd.**
 Year of Existing Counts: 2024
 Horizon Year: 2025

(1)

Growth Rates 0.50% 0.50% 0.50% 0.50%

	Eastbound (Mountain Rd.)			Westbound (Mountain Rd.)			Northbound (I-25 Frntg. Rd.)			Southbound (I-25 Frntg. Rd.)		
	Left	Thru	Right	Left	Thru	Right	Left	Thru	Right	Left	Thru	Right
Base Demand Volumes	0	100	76	0	132	0	0	0	0	268	1,632	316
Background Traffic Growth	0	1	0	0	1	0	0	0	0	1	8	2
Subtotal (NO BUILD - A.M.)	0	101	76	0	133	0	0	0	0	269	1,640	318
Percent Office Trips Generated(Entering)	0.00%	0.00%	0.00%	0.00%	12.00%	0.00%	0.00%	0.00%	0.00%	0.00%	0.00%	50.00%
Percent Office Trips Generated(Exiting)	0.00%	40.00%	19.00%	0.00%	0.00%	0.00%	0.00%	0.00%	0.00%	0.00%	0.00%	0.00%
Total Trips Generated	0	3	2	0	3	0	0	0	0	0	0	14
Total AM Peak Hour BUILD Volumes	0	104	78	0	136	0	0	0	0	269	1,640	332

	Eastbound (Mountain Rd.)			Westbound (Mountain Rd.)			Northbound (I-25 Frntg. Rd.)			Southbound (I-25 Frntg. Rd.)		
	Left	Thru	Right	Left	Thru	Right	Left	Thru	Right	Left	Thru	Right
Base Demand Volumes	0	312	148	4	72	0	0	0	0	24	728	160
Background Traffic Growth	0	2	1	0	0	0	0	0	0	0	4	1
Subtotal (NO BUILD - P.M.)	0	314	149	4	72	0	0	0	0	24	732	161
Percent Office Trips Generated(Entering)	0.00%	0.00%	0.00%	0.00%	12.00%	0.00%	0.00%	0.00%	0.00%	0.00%	0.00%	50.00%
Percent Office Trips Generated(Exiting)	0.00%	40.00%	19.00%	0.00%	0.00%	0.00%	0.00%	0.00%	0.00%	0.00%	0.00%	0.00%
Total Trips Generated	0	9	4	0	2	0	0	0	0	0	0	8
Total PM Peak Hour BUILD Volumes	0	323	153	4	74	0	0	0	0	24	732	169

Number of Office Trips Generated	Entering	Exiting	A.M.	100% Office Development
	27	8		
	15	22	P.M.	

2025
NO BUILD

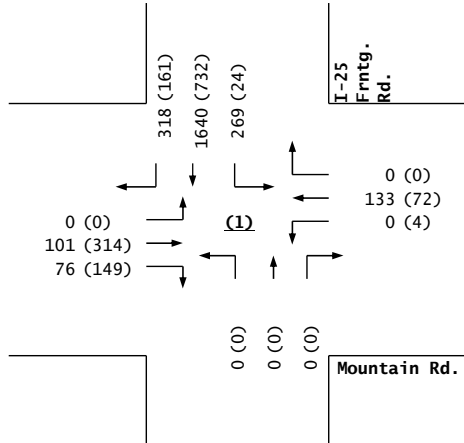

Trips

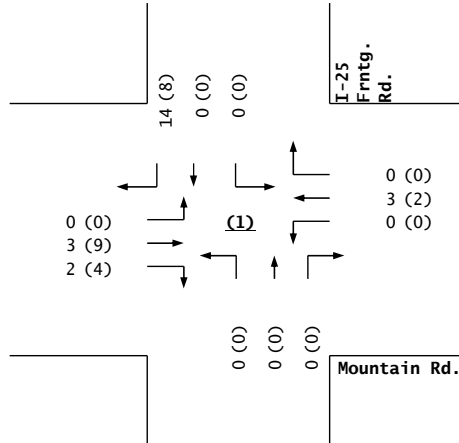

2025
BUILD

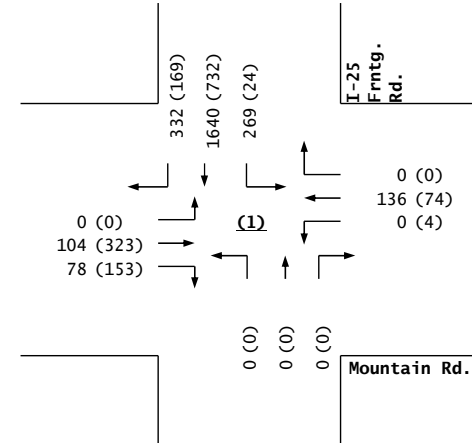

Mountain Rd. / I-25 Frntg. Rd.

Mountain Rd. Rehabilitation Hospital (Mountain Rd. / Woodward Pl.)
 Projected Turning Movements Worksheet
Lomas Blvd. / I-25 W. Frntg

Base Case (Full Access at Mountain Rd. / Woodward Pl.)

INTERSECTION : E-W Street: **Lomas Blvd.**
 N-S Street: **I-25 W. Frntg**
 Year of Existing Counts: 2024
 Horizon Year: 2025

(2)

Growth Rates 0.50% 0.50% 0.50% 0.50%

	Eastbound (Lomas Blvd.)			Westbound (Lomas Blvd.)			Northbound (I-25 W. Frntg)			Southbound (I-25 W. Frntg)		
	Left	Thru	Right	Left	Thru	Right	Left	Thru	Right	Left	Thru	Right
Base Demand Volumes	0	832	140	88	956	0	0	0	0	752	260	468
Background Traffic Growth	0	4	1	0	5	0	0	0	0	4	1	2
Subtotal (NO BUILD - A.M.)	0	836	141	88	961	0	0	0	0	756	261	470
Percent Office Trips Generated(Entering)	0.00%	0.00%	0.00%	0.00%	16.00%	0.00%	0.00%	0.00%	0.00%	0.00%	0.00%	0.00%
Percent Office Trips Generated(Exiting)	0.00%	14.00%	5.00%	0.00%	0.00%	0.00%	0.00%	0.00%	0.00%	14.00%	5.00%	0.00%
Total Trips Generated	0	1	0	0	4	0	0	0	0	1	0	0
Total AM Peak Hour BUILD Volumes	0	837	141	88	965	0	0	0	0	757	261	470

	Eastbound (Lomas Blvd.)			Westbound (Lomas Blvd.)			Northbound (I-25 W. Frntg)			Southbound (I-25 W. Frntg)		
	Left	Thru	Right	Left	Thru	Right	Left	Thru	Right	Left	Thru	Right
Base Demand Volumes	0	940	216	208	992	0	0	0	0	316	328	188
Background Traffic Growth	0	5	1	1	5	0	0	0	0	2	2	1
Subtotal (NO BUILD - P.M.)	0	945	217	209	997	0	0	0	0	318	330	189
Percent Office Trips Generated(Entering)	0.00%	0.00%	0.00%	0.00%	16.00%	0.00%	0.00%	0.00%	0.00%	0.00%	0.00%	0.00%
Percent Office Trips Generated(Exiting)	0.00%	14.00%	5.00%	0.00%	0.00%	0.00%	0.00%	0.00%	0.00%	14.00%	5.00%	0.00%
Total Trips Generated	0	3	1	0	2	0	0	0	0	3	1	0
Total PM Peak Hour BUILD Volumes	0	948	218	209	999	0	0	0	0	321	331	189

Number of Office Trips Generated	Entering	Exiting	A.M.	100% Office Development
	27	8		
	15	22	P.M.	

2025
NO BUILD

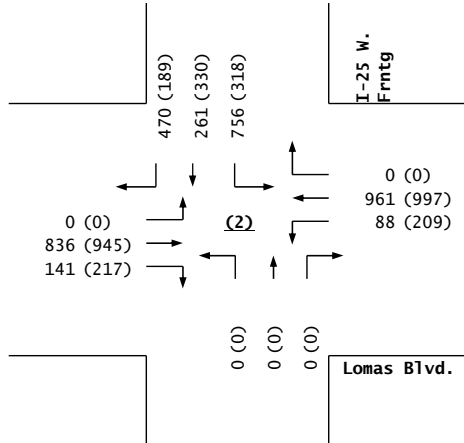

Trips

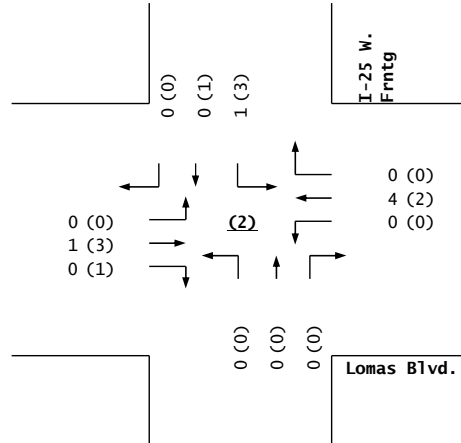

Lomas Blvd. / I-25 W. Frntg

2025
BUILD

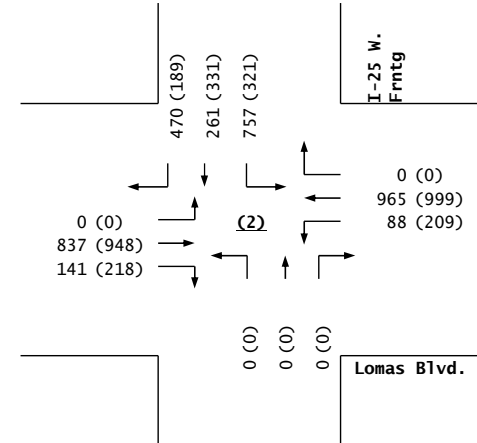

2025
NO BUILD

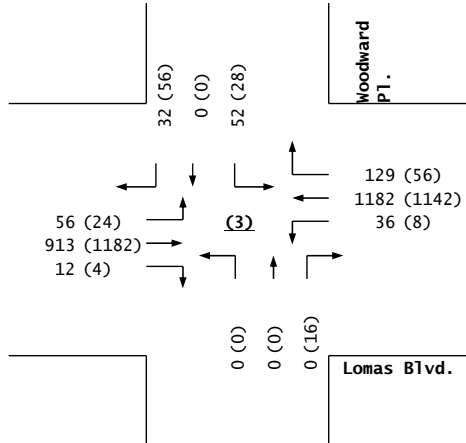

Trips

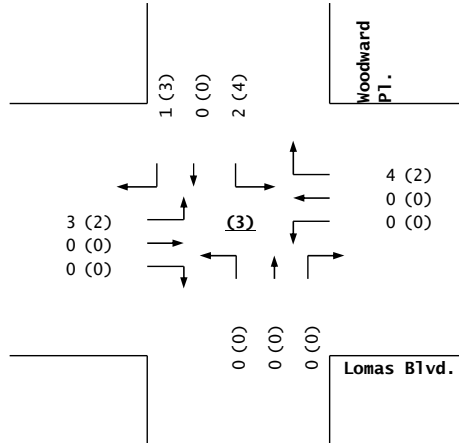

2025
BUILD

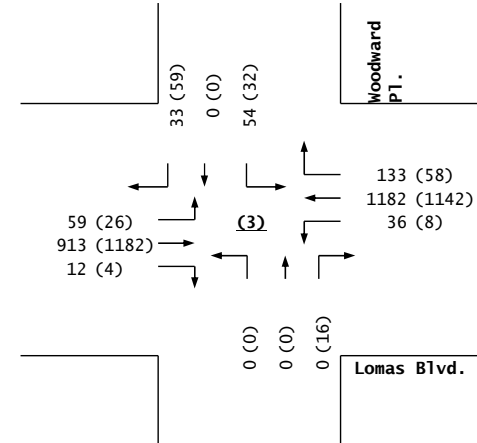

Lomas Blvd. / Woodward Pl.

Mountain Rd. Rehabilitation Hospital (Mountain Rd. / Woodward Pl.)

Projected Turning Movements Worksheet

Mountain Rd. / Woodward Pl.

Base Case (Full Access at Mountain Rd. / Woodward Pl.)

INTERSECTION : E-W Street: **Mountain Rd.**
 N-S Street: **Woodward Pl.**
 Year of Existing Counts: 2024
 Horizon Year: 2025

(4)

Growth Rates 0.50% 0.50% 0.50% 0.50%

	Eastbound (Mountain Rd.)			Westbound (Mountain Rd.)			Northbound (Woodward Pl.)			Southbound (Woodward Pl.)		
	Left	Thru	Right	Left	Thru	Right	Left	Thru	Right	Left	Thru	Right
Base Demand Volumes	0	176	48	100	484	0	44	0	52	0	0	0
Background Traffic Growth	0	1	0	1	2	0	0	0	0	0	0	0
Subtotal (NO BUILD - A.M.)	0	177	48	101	486	0	44	0	52	0	0	0
Percent Office Trips Generated(Entering)	0.00%	9.00%	0.00%	62.00%	0.00%	0.00%	0.00%	0.00%	0.00%	0.00%	0.00%	0.00%
Percent Office Trips Generated(Exiting)	0.00%	0.00%	0.00%	0.00%	0.00%	0.00%	9.00%	0.00%	4.00%	0.00%	0.00%	0.00%
Total Trips Generated	0	2	0	17	0	0	1	0	0	0	0	0
Total AM Peak Hour BUILD Volumes	0	179	48	118	486	0	45	0	52	0	0	0

	Eastbound (Mountain Rd.)			Westbound (Mountain Rd.)			Northbound (Woodward Pl.)			Southbound (Woodward Pl.)		
	Left	Thru	Right	Left	Thru	Right	Left	Thru	Right	Left	Thru	Right
Base Demand Volumes	0	116	4	24	352	0	68	0	96	0	0	0
Background Traffic Growth	0	1	0	0	2	0	0	0	0	0	0	0
Subtotal (NO BUILD - P.M.)	0	117	4	24	354	0	68	0	96	0	0	0
Percent Office Trips Generated(Entering)	0.00%	9.00%	0.00%	62.00%	0.00%	0.00%	0.00%	0.00%	0.00%	0.00%	0.00%	0.00%
Percent Office Trips Generated(Exiting)	0.00%	0.00%	0.00%	0.00%	0.00%	0.00%	9.00%	0.00%	4.00%	0.00%	0.00%	0.00%
Total Trips Generated	0	1	0	9	0	0	2	0	1	0	0	0
Total PM Peak Hour BUILD Volumes	0	118	4	33	354	0	70	0	97	0	0	0

Number of Office Trips Generated	Entering	Exiting	A.M.	100% Office Development
	27	8		
	15	22	P.M.	

2025
NO BUILD

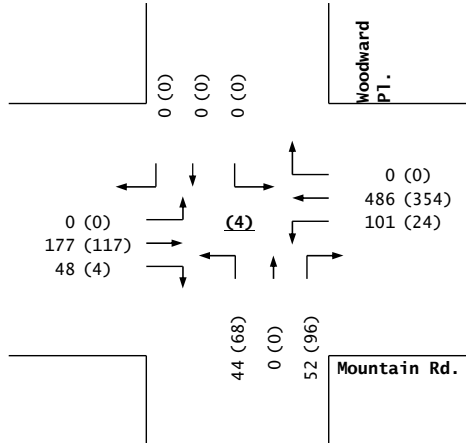

Trips

2025
BUILD

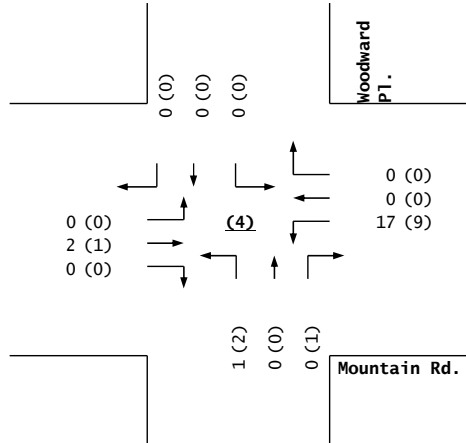

Mountain Rd. / Woodward Pl.

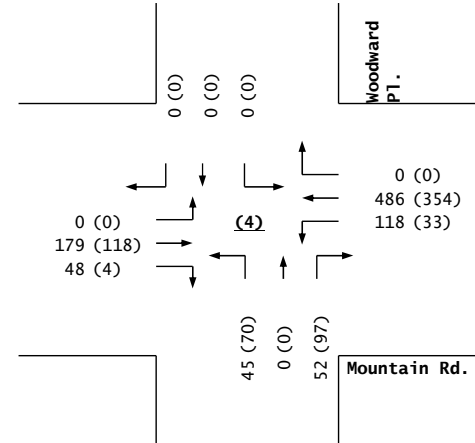

Mountain Rd. Rehabilitation Hospital (Mountain Rd. / Woodward Pl.)

Projected Turning Movements Worksheet

Mountain Rd. / AHS W. Driveway

Base Case (Full Access at Mountain Rd. / Woodward Pl.)

INTERSECTION : E-W Street: **Mountain Rd.** (5)
 N-S Street: **AHS W. Driveway**
 Year of Existing Counts: 2024
 Horizon Year: 2025

Growth Rates: 0.50% 0.50% 0.50% 0.50%

	Eastbound (Mountain Rd.)			Westbound (Mountain Rd.)			Northbound (AHS W. Driveway)			Southbound (AHS W. Driveway)		
	Left	Thru	Right	Left	Thru	Right	Left	Thru	Right	Left	Thru	Right
Base Demand Volumes	76	192	0	0	232	204	0	0	0	108	0	108
Background Traffic Growth	0	1	0	0	1	1	0	0	0	1	0	1
Subtotal (NO BUILD - A.M.)	76	193	0	0	233	205	0	0	0	109	0	109
Percent Office Trips Generated(Entering)	0.00%	9.00%	0.00%	0.00%	0.00%	0.00%	0.00%	0.00%	0.00%	0.00%	0.00%	0.00%
Percent Office Trips Generated(Exiting)	0.00%	0.00%	0.00%	0.00%	9.00%	0.00%	0.00%	0.00%	0.00%	0.00%	0.00%	0.00%
Total Trips Generated	0	2	0	0	1	0	0	0	0	0	0	0
Total AM Peak Hour BUILD Volumes	76	195	0	0	234	205	0	0	0	109	0	109

	Eastbound (Mountain Rd.)			Westbound (Mountain Rd.)			Northbound (AHS W. Driveway)			Southbound (AHS W. Driveway)		
	Left	Thru	Right	Left	Thru	Right	Left	Thru	Right	Left	Thru	Right
Base Demand Volumes	20	132	0	0	232	44	0	0	0	200	0	184
Background Traffic Growth	0	1	0	0	1	0	0	0	0	1	0	1
Subtotal (NO BUILD - P.M.)	20	133	0	0	233	44	0	0	0	201	0	185
Percent Office Trips Generated(Entering)	0.00%	9.00%	0.00%	0.00%	0.00%	0.00%	0.00%	0.00%	0.00%	0.00%	0.00%	0.00%
Percent Office Trips Generated(Exiting)	0.00%	0.00%	0.00%	0.00%	9.00%	0.00%	0.00%	0.00%	0.00%	0.00%	0.00%	0.00%
Total Trips Generated	0	1	0	0	2	0	0	0	0	0	0	0
Total PM Peak Hour BUILD Volumes	20	134	0	0	235	44	0	0	0	201	0	185

Number of Office Trips Generated: Entering 27, Exiting 8 A.M. 100% Office Development
 Entering 15, Exiting 22 P.M.

2025
NO BUILD

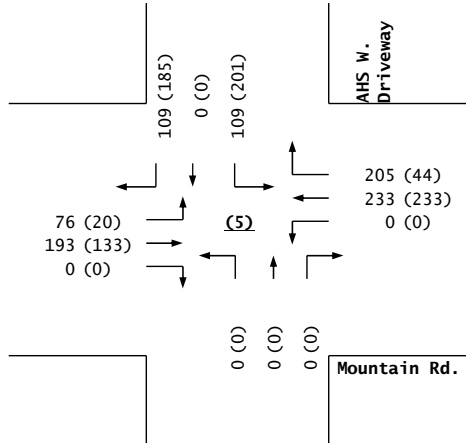

Trips

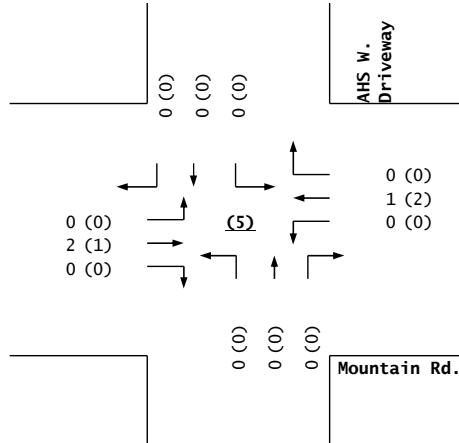

2025
BUILD

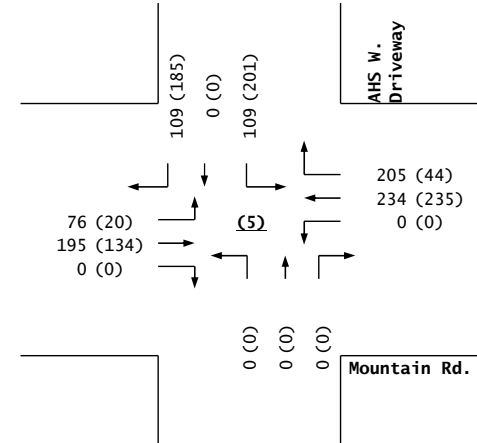

Mountain Rd. / AHS W. Driveway

Mountain Rd. Rehabilitation Hospital (Mountain Rd. / Woodward Pl.)

Projected Turning Movements Worksheet

Mountain Rd. / AHS Cntr Drvwy

Base Case (Full Access at Mountain Rd. / Woodward Pl.)

INTERSECTION : E-W Street: **Mountain Rd.**
 N-S Street: **AHS Cntr Drvwy**
 Year of Existing Counts: 2024
 Horizon Year: 2025

(6)

Growth Rates: 0.50% 0.50% 0.50% 0.50%

	Eastbound (Mountain Rd.)			Westbound (Mountain Rd.)			Northbound (AHS Cntr Drvwy)			Southbound (AHS Cntr Drvwy)		
	Left	Thru	Right	Left	Thru	Right	Left	Thru	Right	Left	Thru	Right
Base Demand Volumes	0	228	0	0	564	0	0	0	0	2	0	2
Background Traffic Growth	0	1	0	0	3	0	0	0	0	0	0	0
Subtotal (NO BUILD - A.M.)	0	229	0	0	567	0	0	0	0	2	0	2
Percent Office Trips Generated(Entering)	0.00%	0.00%	9.00%	0.00%	62.00%	0.00%	0.00%	0.00%	0.00%	0.00%	0.00%	0.00%
Percent Office Trips Generated(Exiting)	0.00%	4.00%	0.00%	0.00%	0.00%	0.00%	0.00%	0.00%	55.00%	0.00%	0.00%	0.00%
Total Trips Generated	0	0	2	0	17	0	0	0	4	0	0	0
Total AM Peak Hour BUILD Volumes	0	229	2	0	584	0	0	0	4	2	0	2

	Eastbound (Mountain Rd.)			Westbound (Mountain Rd.)			Northbound (AHS Cntr Drvwy)			Southbound (AHS Cntr Drvwy)		
	Left	Thru	Right	Left	Thru	Right	Left	Thru	Right	Left	Thru	Right
Base Demand Volumes	0	360	0	0	280	0	0	0	0	4	0	4
Background Traffic Growth	0	2	0	0	1	0	0	0	0	0	0	0
Subtotal (NO BUILD - P.M.)	0	362	0	0	281	0	0	0	0	4	0	4
Percent Office Trips Generated(Entering)	0.00%	0.00%	9.00%	0.00%	62.00%	0.00%	0.00%	0.00%	0.00%	0.00%	0.00%	0.00%
Percent Office Trips Generated(Exiting)	0.00%	4.00%	0.00%	0.00%	0.00%	0.00%	0.00%	0.00%	55.00%	0.00%	0.00%	0.00%
Total Trips Generated	0	1	1	0	9	0	0	0	12	0	0	0
Total PM Peak Hour BUILD Volumes	0	363	1	0	290	0	0	0	12	4	0	4

Number of Office Trips Generated: Entering 27, Exiting 8 A.M. 100% Office Development, Entering 15, Exiting 22 P.M.

2025
NO BUILD

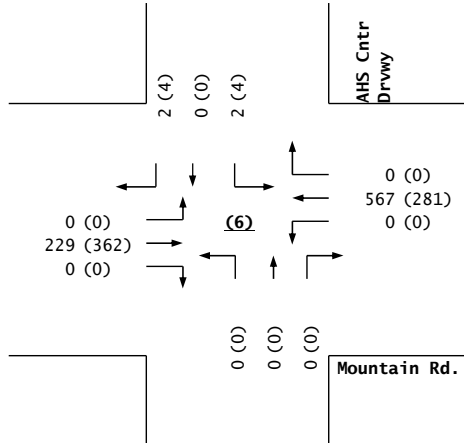

Trips

2025
BUILD

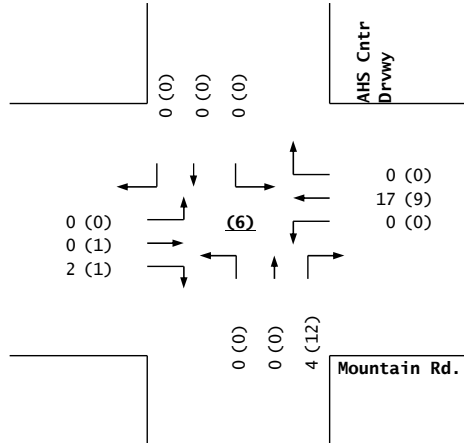

Mountain Rd. / AHS Cntr Drwy

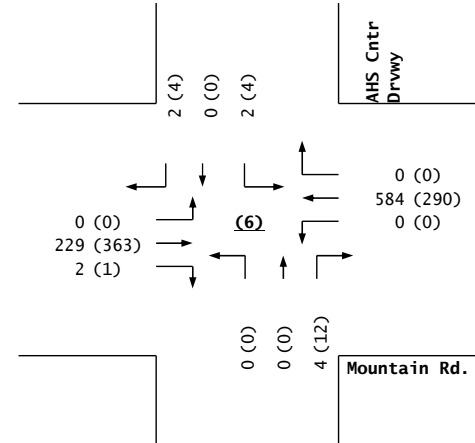

Mountain Rd. Rehabilitation Hospital (Mountain Rd. / Woodward Pl.)

Projected Turning Movements Worksheet

Mountain Rd. / AHS E. Driveway

Base Case (Full Access at Mountain Rd. / Woodward Pl.)

INTERSECTION : E-W Street: **Mountain Rd.** (7)
 N-S Street: **AHS E. Driveway**
 Year of Existing Counts: 2024
 Horizon Year: 2025

Growth Rates: 0.50% 0.50% 0.50% 0.50%

	Eastbound (Mountain Rd.)			Westbound (Mountain Rd.)			Northbound (AHS E. Driveway)			Southbound (AHS E. Driveway)		
	Left	Thru	Right	Left	Thru	Right	Left	Thru	Right	Left	Thru	Right
Base Demand Volumes	80	168	0	0	508	196	0	0	0	80	0	60
Background Traffic Growth	0	1	0	0	3	1	0	0	0	0	0	0
Subtotal (NO BUILD - A.M.)	80	169	0	0	511	197	0	0	0	80	0	60
Percent Office Trips Generated(Entering)	0.00%	0.00%	0.00%	0.00%	62.00%	0.00%	0.00%	0.00%	0.00%	0.00%	0.00%	0.00%
Percent Office Trips Generated(Exiting)	0.00%	59.00%	0.00%	0.00%	0.00%	0.00%	0.00%	0.00%	0.00%	0.00%	0.00%	0.00%
Total Trips Generated	0	5	0	0	17	0	0	0	0	0	0	0
Total AM Peak Hour BUILD Volumes	80	174	0	0	528	197	0	0	0	80	0	60

	Eastbound (Mountain Rd.)			Westbound (Mountain Rd.)			Northbound (AHS E. Driveway)			Southbound (AHS E. Driveway)		
	Left	Thru	Right	Left	Thru	Right	Left	Thru	Right	Left	Thru	Right
Base Demand Volumes	28	324	0	0	232	40	0	0	0	136	0	116
Background Traffic Growth	0	2	0	0	1	0	0	0	0	1	0	1
Subtotal (NO BUILD - P.M.)	28	326	0	0	233	40	0	0	0	137	0	117
Percent Office Trips Generated(Entering)	0.00%	0.00%	0.00%	0.00%	62.00%	0.00%	0.00%	0.00%	0.00%	0.00%	0.00%	0.00%
Percent Office Trips Generated(Exiting)	0.00%	59.00%	0.00%	0.00%	0.00%	0.00%	0.00%	0.00%	0.00%	0.00%	0.00%	0.00%
Total Trips Generated	0	13	0	0	9	0	0	0	0	0	0	0
Total PM Peak Hour BUILD Volumes	28	339	0	0	242	40	0	0	0	137	0	117

Number of Office Trips Generated:
 Entering: 27 Exiting: 8 A.M. 100% Office Development
 15 22 P.M.

2025
NO BUILD

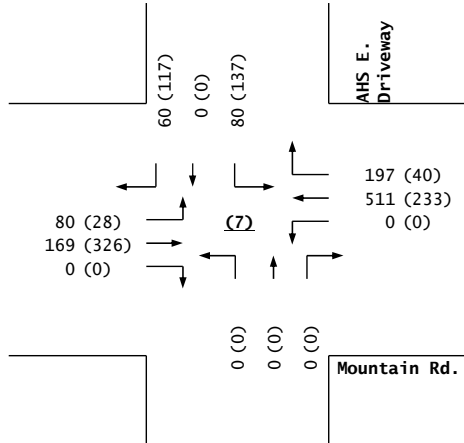

Trips

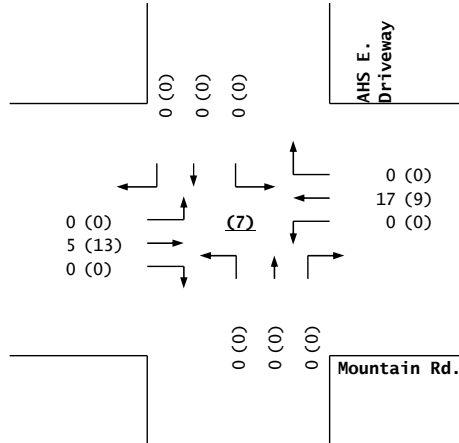

2025
BUILD

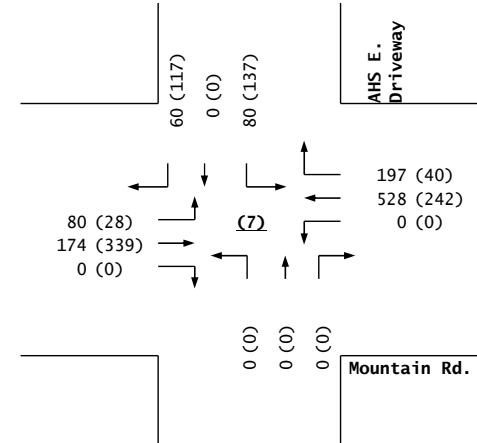

Mountain Rd. / AHS E. Driveway

Mountain Rd. Rehabilitation Hospital (Mountain Rd. / Woodward Pl.)

Projected Turning Movements Worksheet

Embassy Drvwy / Woodward Pl.

Base Case (Full Access at Mountain Rd. / Woodward Pl.)

INTERSECTION : E-W Street: **Embassy Drvwy** (8)
 N-S Street: **Woodward Pl.**
 Year of Existing Counts: 2024
 Horizon Year: **2025**
 Growth Rates: **0.50%** **0.50%** **0.50%** **0.50%**

	Eastbound (Embassy Drvwy)			Westbound (Embassy Drvwy)			Northbound (Woodward Pl.)			Southbound (Woodward Pl.)		
	Left	Thru	Right	Left	Thru	Right	Left	Thru	Right	Left	Thru	Right
Base Demand Volumes	12	0	8	8	0	8	28	68	12	44	40	16
Background Traffic Growth	0	0	0	0	0	0	0	0	0	0	0	0
Subtotal (NO BUILD - A.M.)	12	0	8	8	0	8	28	68	12	44	40	16
Percent Office Trips Generated(Entering)	0.00%	0.00%	0.00%	0.00%	0.00%	0.00%	0.00%	29.00%	0.00%	62.00%	0.00%	0.00%
Percent Office Trips Generated(Exiting)	0.00%	0.00%	0.00%	32.00%	0.00%	0.00%	0.00%	0.00%	0.00%	0.00%	0.00%	0.00%
Total Trips Generated	0	0	0	3	0	0	0	8	0	17	0	0
Total AM Peak Hour BUILD Volumes	12	0	8	11	0	8	28	76	12	61	40	16

	Eastbound (Embassy Drvwy)			Westbound (Embassy Drvwy)			Northbound (Woodward Pl.)			Southbound (Woodward Pl.)		
	Left	Thru	Right	Left	Thru	Right	Left	Thru	Right	Left	Thru	Right
Base Demand Volumes	48	0	8	20	0	56	0	84	4	4	20	4
Background Traffic Growth	0	0	0	0	0	0	0	0	0	0	0	0
Subtotal (NO BUILD - P.M.)	48	0	8	20	0	56	0	84	4	4	20	4
Percent Office Trips Generated(Entering)	0.00%	0.00%	0.00%	0.00%	0.00%	0.00%	0.00%	29.00%	0.00%	62.00%	0.00%	0.00%
Percent Office Trips Generated(Exiting)	0.00%	0.00%	0.00%	32.00%	0.00%	0.00%	0.00%	0.00%	0.00%	0.00%	0.00%	0.00%
Total Trips Generated	0	0	0	7	0	0	0	4	0	9	0	0
Total PM Peak Hour BUILD Volumes	48	0	8	27	0	56	0	88	4	13	20	4

Number of Office Trips Generated: Entering 27, Exiting 8 A.M. 100% Office Development
 Entering 15, Exiting 22 P.M.

2025
NO BUILD

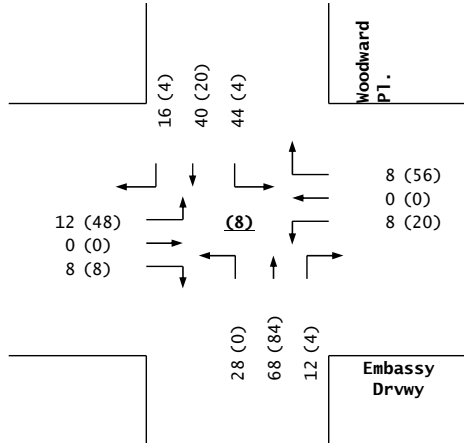

Trips

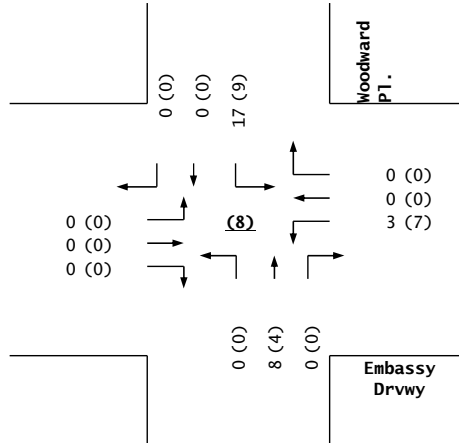

2025
BUILD

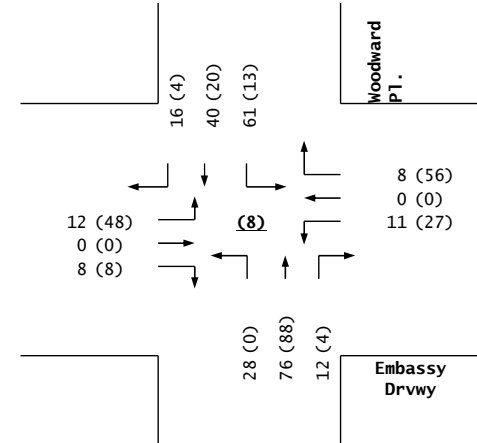

Embassy Drvwy / Woodward Pl.

Mountain Rd. Rehabilitation Hospital (Mountain Rd. / Woodward Pl.)
 Projected Turning Movements Worksheet
Driveway "A" / Woodward Pl.

INTERSECTION : E-W Street: **Driveway "A"** (9)
 N-S Street: **Woodward Pl.**
 Year of Existing Counts: 2024
 Horizon Year: 2025

Growth Rates 0.50% 0.50% 0.50% 0.50%

	0.50%			0.50%			0.50%			0.50%		
	Eastbound (Driveway "A")			Westbound (Driveway "A")			Northbound (Woodward Pl.)			Southbound (Woodward Pl.)		
	Left	Thru	Right	Left	Thru	Right	Left	Thru	Right	Left	Thru	Right
Base Demand Volumes	0	0	0	0	0	0	0	0	0	0	0	0
Background Traffic Growth	0	0	0	0	0	0	0	0	0	0	0	0
Subtotal (NO BUILD - A.M.)	0	0	0	0	0	0	0	96	0	0	149	0
Percent Office Trips Generated(Entering)	0.00%	0.00%	0.00%	0.00%	0.00%	0.00%	0.00%	0.00%	29.00%	0.00%	0.00%	0.00%
Percent Office Trips Generated(Exiting)	0.00%	0.00%	0.00%	0.00%	0.00%	13.00%	0.00%	0.00%	0.00%	0.00%	0.00%	0.00%
Total Trips Generated	0	0	0	0	0	1	0	0	8	0	0	0
Total AM Peak Hour BUILD Volumes	0	0	0	0	0	1	0	96	8	0	149	0

	0.50%			0.50%			0.50%			0.50%		
	Eastbound (Driveway "A")			Westbound (Driveway "A")			Northbound (Woodward Pl.)			Southbound (Woodward Pl.)		
	Left	Thru	Right	Left	Thru	Right	Left	Thru	Right	Left	Thru	Right
Base Demand Volumes	0	0	0	0	0	0	0	0	0	0	0	0
Background Traffic Growth	0	0	0	0	0	0	0	0	0	0	0	0
Subtotal (NO BUILD - P.M.)	0	0	0	0	0	0	0	164	0	0	28	0
Percent Office Trips Generated(Entering)	0.00%	0.00%	0.00%	0.00%	0.00%	0.00%	0.00%	0.00%	29.00%	0.00%	0.00%	0.00%
Percent Office Trips Generated(Exiting)	0.00%	0.00%	0.00%	0.00%	0.00%	13.00%	0.00%	0.00%	0.00%	0.00%	0.00%	0.00%
Total Trips Generated	0	0	0	0	0	3	0	0	4	0	0	0
Total PM Peak Hour BUILD Volumes	0	0	0	0	0	3	0	164	4	0	28	0

Number of Office Trips Generated

Entering	Exiting		
27	8	A.M.	100% Office Development
15	22	P.M.	

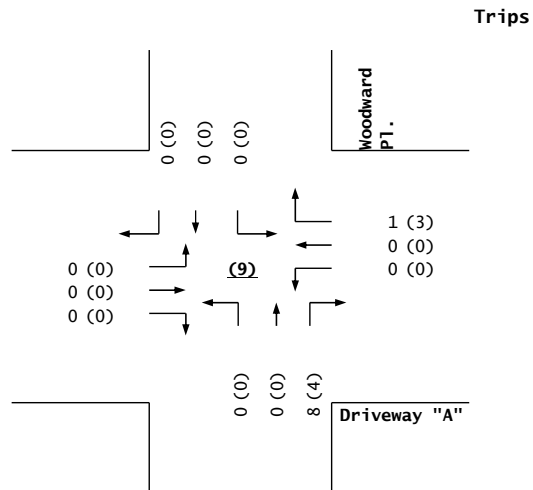
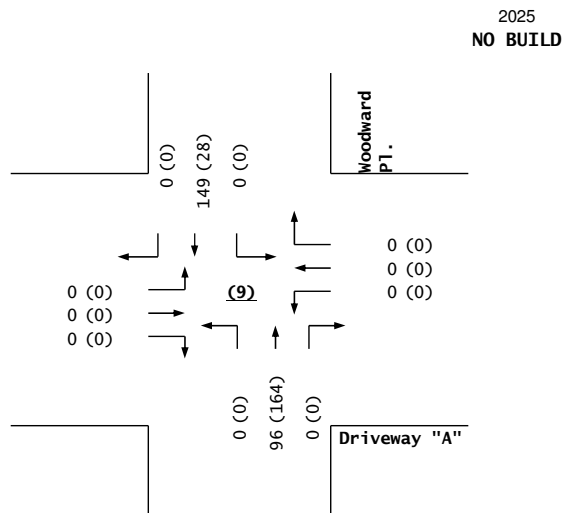

Driveway "A" / Woodward Pl.

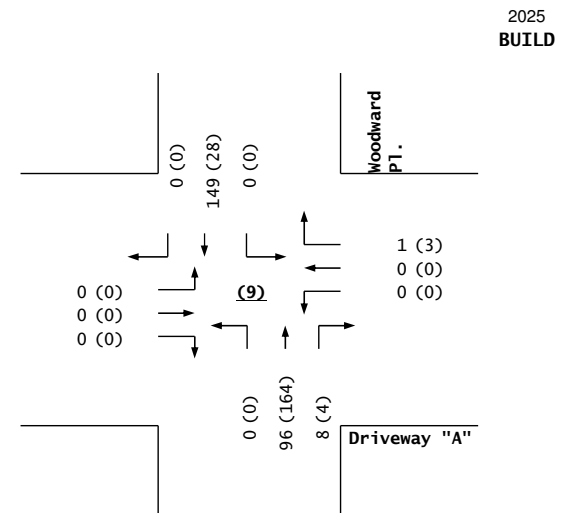

**Pages A-42 through A-146
(INTENTIONALLY LEFT BLANK)**

Timings
1: W. Frntg Rd & Mountain Rd.

Tierra West, LLC
06/29/2024

	→	←	↓
Lane Group	EBT	WBT	SBT
Lane Configurations	↔↔	↑	↔↔↔
Traffic Volume (vph)	101	133	1640
Future Volume (vph)	101	133	1640
Turn Type	NA	NA	NA
Protected Phases	4	8	6
Permitted Phases			
Detector Phase	4	8	6
Switch Phase			
Minimum Initial (s)	8.0	8.0	16.0
Minimum Split (s)	23.5	23.5	25.0
Total Split (s)	24.0	24.0	36.0
Total Split (%)	40.0%	40.0%	60.0%
Yellow Time (s)	3.5	3.5	5.0
All-Red Time (s)	2.0	2.0	2.0
Lost Time Adjust (s)	0.0	0.0	0.0
Total Lost Time (s)	5.5	5.5	7.0
Lead/Lag			
Lead-Lag Optimize?			
Recall Mode	None	None	Max

Intersection Summary	
Cycle Length:	60
Actuated Cycle Length:	51.3
Natural Cycle:	60
Control Type:	Actuated-Uncoordinated

Splits and Phases: 1: W. Frntg Rd & Mountain Rd.

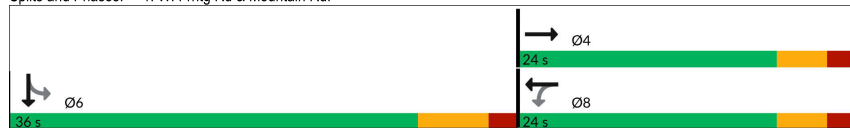

HCM 7th Signalized Intersection Summary
1: W. Frntg Rd & Mountain Rd.

Tierra West, LLC
06/29/2024

	↔	↔	↔	↔	↔	↔	↔	↔	↔	↔	↔	↔
Movement	EBL	EBT	EBR	WBL	WBT	WBR	NBL	NBT	NBR	SBL	SBT	SBR
Lane Configurations		↔↔		↔	↔						↔↔↔	
Traffic Volume (veh/h)	0	101	76	0	133	0	0	0	0	269	1640	318
Future Volume (veh/h)	0	101	76	0	133	0	0	0	0	269	1640	318
Initial Q (Qb), veh	0	0	0	0	0	0	0	0	0	0	0	0
Lane Width Adj.	1.00	1.00	1.00	1.00	1.00	1.00				1.00	1.00	1.00
Ped-Bike Adj(A_pbT)	1.00	1.00	1.00	1.00	1.00	1.00				1.00	1.00	1.00
Parking Bus, Adj	1.00	1.00	1.00	1.00	1.00	1.00				1.00	1.00	1.00
Work Zone On Approach	No			No						No		
Adj Sat Flow, veh/h/ln	0	1856	1856	1856	1856	0				1856	1856	1856
Adj Flow Rate, veh/h	0	101	0	0	133	0				269	1640	318
Peak Hour Factor	1.00	1.00	1.00	1.00	1.00	1.00				1.00	1.00	1.00
Percent Heavy Veh. %	0	3	3	3	3	0				3	3	3
Cap, veh/h	0	550		146	290	0				374	2277	436
Arrive On Green	0.00	0.16	0.00	0.00	0.16	0.00				0.59	0.59	0.59
Sat Flow, veh/h	0	3711	0	1283	1856	0				635	3862	739
Grp Volume(v), veh/h	0	101	0	0	133	0				773	712	741
Grp Sat Flow(s), veh/h/ln	0	1763	0	1283	1856	0				1824	1689	1723
Q Serve(g_s), s	0.0	1.2	0.0	0.0	3.2	0.0				14.8	14.7	15.2
Cycle Q Clear(g_c), s	0.0	1.2	0.0	0.0	3.2	0.0				14.8	14.7	15.2
Prop In Lane	0.00		0.00			0.00				0.35		0.43
Lane Grp Cap(c), veh/h	0	550		146	290	0				1076	996	1016
V/C Ratio(X)	0.00	0.18		0.00	0.46	0.00				0.72	0.72	0.73
Avail Cap(c_a), veh/h	0	1326		429	698	0				1076	996	1016
HCM Platoon Ratio	1.00	1.00	1.00	1.00	1.00	1.00				1.00	1.00	1.00
Upstream Filter(I)	0.00	1.00	0.00	0.00	1.00	0.00				1.00	1.00	1.00
Uniform Delay (d), s/veh	0.0	18.0	0.0	0.0	18.9	0.0				7.2	7.2	7.3
Incr Delay (d2), s/veh	0.0	0.2	0.0	0.0	1.1	0.0				4.1	4.4	4.6
Initial Q Delay(d3), s/veh	0.0	0.0	0.0	0.0	0.0	0.0				0.0	0.0	0.0
%ile BackOfQ(95%),veh/ln	0.0	0.9	0.0	0.0	2.4	0.0				7.7	7.2	7.6
Unsig. Movement Delay, s/veh												
LnGrp Delay(d), s/veh	0.0	18.2	0.0	0.0	20.0	0.0				11.3	11.6	11.9
LnGrp LOS		B			C					B	B	B
Approach Vol, veh/h		101			133						2227	
Approach Delay, s/veh		18.2			20.0						11.6	
Approach LOS		B			C						B	
Timer - Assigned Phs				4		6			8			
Phs Duration (G+Y+Rc), s				13.2		36.0			13.2			
Change Period (Y+Rc), s				5.5		7.0			5.5			
Max Green Setting (Gmax), s				18.5		29.0			18.5			
Max Q Clear Time (g_c+1), s				3.2		17.2			5.2			
Green Ext Time (p_c), s				0.4		9.6			0.5			

Intersection Summary	
HCM 7th Control Delay, s/veh	12.3
HCM 7th LOS	B

Notes
Unsignalized Delay for [EBR] is excluded from calculations of the approach delay and intersection delay.

Timings
1: W. Frntg Rd & Mountain Rd.

Tierra West, LLC
06/29/2024

	→	←	↓
Lane Group	EBT	WBT	SBT
Lane Configurations	↑↑	↑	↑↑↑
Traffic Volume (vph)	104	136	1640
Future Volume (vph)	104	136	1640
Turn Type	NA	NA	NA
Protected Phases	4	8	6
Permitted Phases			
Detector Phase	4	8	6
Switch Phase			
Minimum Initial (s)	8.0	8.0	16.0
Minimum Split (s)	23.5	23.5	25.0
Total Split (s)	24.0	24.0	36.0
Total Split (%)	40.0%	40.0%	60.0%
Yellow Time (s)	3.5	3.5	5.0
All-Red Time (s)	2.0	2.0	2.0
Lost Time Adjust (s)	0.0	0.0	0.0
Total Lost Time (s)	5.5	5.5	7.0
Lead/Lag			
Lead-Lag Optimize?			
Recall Mode	None	None	Max

Intersection Summary			
Cycle Length:	60		
Actuated Cycle Length:	51.3		
Natural Cycle:	60		
Control Type:	Actuated-Uncoordinated		

Splits and Phases: 1: W. Frntg Rd & Mountain Rd.

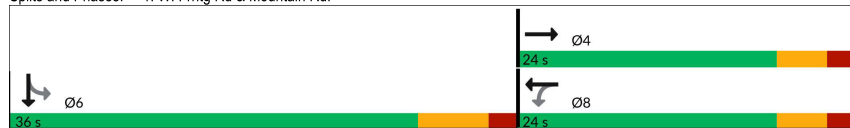

2025 AM Peak Hour BUILD Condition - Base Case

Synchro 12 Report
Base syn

HCM 7th Signalized Intersection Summary
1: W. Frntg Rd & Mountain Rd.

Tierra West, LLC
06/29/2024

	↗	→	↘	↙	←	↖	↗	↘	↙	↖	↗	↘	↙	↖
Movement	EBL	EBT	EBR	WBL	WBT	WBR	NBL	NBT	NBR	SBL	SBT	SBR		
Lane Configurations		↑↑		↙	↑						↑↑↑			
Traffic Volume (veh/h)	0	104	78	0	136	0	0	0	0	269	1640	332		
Future Volume (veh/h)	0	104	78	0	136	0	0	0	0	269	1640	332		
Initial Q (Qb), veh	0	0	0	0	0	0				0	0	0		
Lane Width Adj.	1.00	1.00	1.00	1.00	1.00	1.00				1.00	1.00	1.00		
Ped-Bike Adj(A_pbT)	1.00	1.00	1.00	1.00	1.00	1.00				1.00	1.00	1.00		
Parking Bus, Adj	1.00	1.00	1.00	1.00	1.00	1.00				1.00	1.00	1.00		
Work Zone On Approach	No				No					No				
Adj Sat Flow, veh/h/ln	0	1856	1856	1856	1856	0				1856	1856	1856		
Adj Flow Rate, veh/h	0	104	0	0	136	0				269	1640	332		
Peak Hour Factor	1.00	1.00	1.00	1.00	1.00	1.00				1.00	1.00	1.00		
Percent Heavy Veh. %	0	3	3	3	3	0				3	3	3		
Cap, veh/h	0	552		146	290	0				372	2261	451		
Arrive On Green	0.00	0.16	0.00	0.00	0.16	0.00				0.59	0.59	0.59		
Sat Flow, veh/h	0	3711	0	1280	1856	0				630	3835	765		
Grp Volume(v), veh/h	0	104	0	0	136	0				778	717	745		
Grp Sat Flow(s), veh/h/ln	0	1763	0	1280	1856	0				1824	1689	1718		
Q Serve(g_s), s	0.0	1.3	0.0	0.0	3.3	0.0				15.0	14.9	15.5		
Cycle Q Clear(g_c), s	0.0	1.3	0.0	0.0	3.3	0.0				15.0	14.9	15.5		
Prop In Lane	0.00		0.00	1.00		0.00				0.35		0.45		
Lane Grp Cap(c), veh/h	0	552		146	290	0				1075	995	1013		
V/C Ratio(X)	0.00	0.19		0.00	0.47	0.00				0.72	0.72	0.74		
Avail Cap(c_a), veh/h	0	1326		427	698	0				1075	995	1013		
HCM Platoon Ratio	1.00	1.00	1.00	1.00	1.00	1.00				1.00	1.00	1.00		
Upstream Filter(I)	0.00	1.00	0.00	0.00	1.00	0.00				1.00	1.00	1.00		
Uniform Delay (d), s/veh	0.0	18.0	0.0	0.0	18.9	0.0				7.2	7.2	7.3		
Incr Delay (d2), s/veh	0.0	0.2	0.0	0.0	1.2	0.0				4.2	4.5	4.8		
Initial Q Delay(d3), s/veh	0.0	0.0	0.0	0.0	0.0	0.0				0.0	0.0	0.0		
%ile BackOfQ(95%),veh/ln	0.0	0.9	0.0	0.0	2.5	0.0				7.8	7.3	7.7		
Unsig. Movement Delay, s/veh														
LnGrp Delay(d), s/veh	0.0	18.2	0.0	0.0	20.1	0.0				11.5	11.7	12.1		
LnGrp LOS		B			C					B	B	B		
Approach Vol, veh/h		104			136							2241		
Approach Delay, s/veh		18.2			20.1							11.8		
Approach LOS		B			C							B		
Timer - Assigned Phs				4		6			8					
Phs Duration (G+Y+Rc), s				13.2		36.0			13.2					
Change Period (Y+Rc), s				5.5		7.0			5.5					
Max Green Setting (Gmax), s				18.5		29.0			18.5					
Max Q Clear Time (g_c+1), s				3.3		17.5			5.3					
Green Ext Time (p_c), s				0.4		9.4			0.5					

Intersection Summary	
HCM 7th Control Delay, s/veh	12.5
HCM 7th LOS	B

Notes
Unsignalized Delay for [EBR] is excluded from calculations of the approach delay and intersection delay.

2025 AM Peak Hour BUILD Condition - Base Case

Synchro 12 Report
Base syn

Timings
1: W. Frntg Rd & Mountain Rd.

Tierra West, LLC
06/29/2024

	→	↖	←	↓
Lane Group	EBT	WBL	WBT	SBT
Lane Configurations	↑↑	↖	↑	↑↑↑
Traffic Volume (vph)	314	4	72	732
Future Volume (vph)	314	4	72	732
Turn Type	NA	Perm	NA	NA
Protected Phases	4		8	6
Permitted Phases		8		
Detector Phase	4	8	8	6
Switch Phase				
Minimum Initial (s)	8.0	8.0	8.0	16.0
Minimum Split (s)	23.5	23.5	23.5	25.0
Total Split (s)	24.0	24.0	24.0	36.0
Total Split (%)	40.0%	40.0%	40.0%	60.0%
Yellow Time (s)	3.5	3.5	3.5	5.0
All-Red Time (s)	2.0	2.0	2.0	2.0
Lost Time Adjust (s)	0.0	0.0	0.0	0.0
Total Lost Time (s)	5.5	5.5	5.5	7.0
Lead/Lag				
Lead-Lag Optimize?				
Recall Mode	None	None	None	Max

Intersection Summary	
Cycle Length:	60
Actuated Cycle Length:	53.1
Natural Cycle:	50
Control Type:	Actuated-Uncoordinated

Splits and Phases: 1: W. Frntg Rd & Mountain Rd.

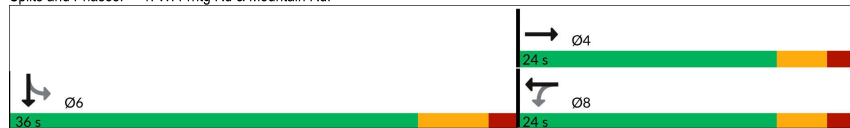

2025 PM Peak Hour NO BUILD Conditions - Base Case

Synchro 12 Report
Base syn

HCM 7th Signalized Intersection Summary
1: W. Frntg Rd & Mountain Rd.

Tierra West, LLC
06/29/2024

	↖	→	↗	↖	←	↖	↗	↖	↗	↖	↗	↖	↗
Movement	EBL	EBT	EBR	WBL	WBT	WBR	NBL	NBT	NBR	SBL	SBT	SBR	
Lane Configurations		↑↑		↖	↑						↑↑↑		
Traffic Volume (veh/h)	0	314	149	4	72	0	0	0	0	24	732	161	
Future Volume (veh/h)	0	314	149	4	72	0	0	0	0	24	732	161	
Initial Q (Qb), veh	0	0	0	0	0	0	0	0	0	0	0	0	
Lane Width Adj.	1.00	1.00	1.00	1.00	1.00	1.00				1.00	1.00	1.00	
Ped-Bike Adj(A_pbT)	1.00	1.00	1.00	1.00	1.00	1.00				1.00	1.00	1.00	
Parking Bus, Adj	1.00	1.00	1.00	1.00	1.00	1.00				1.00	1.00	1.00	
Work Zone On Approach	No				No					No			
Adj Sat Flow, veh/h/ln	0	1856	1856	1856	1856	0				1856	1856	1856	
Adj Flow Rate, veh/h	0	314	0	4	72	0				24	732	161	
Peak Hour Factor	1.00	1.00	1.00	1.00	1.00	1.00				1.00	1.00	1.00	
Percent Heavy Veh. %	0	3	3	3	3	0				3	3	3	
Cap, veh/h	0	568		229	299	0				81	2451	534	
Arrive On Green	0.00	0.16	0.00	0.16	0.16	0.00				0.59	0.59	0.59	
Sat Flow, veh/h	0	3711	0	1057	1856	0				137	4181	911	
Grp Volume(v), veh/h	0	314	0	4	72	0				323	295	299	
Grp Sat Flow(s), veh/h/ln	0	1763	0	1057	1856	0				1849	1689	1692	
Q Serve(g_s), s	0.0	4.1	0.0	0.2	1.7	0.0				4.3	4.3	4.4	
Cycle Q Clear(g_c), s	0.0	4.1	0.0	4.2	1.7	0.0				4.3	4.3	4.4	
Prop In Lane	0.00		0.00	1.00		0.00				0.07		0.54	
Lane Grp Cap(c), veh/h	0	568		229	299	0				1084	990	992	
V/C Ratio(X)	0.00	0.55		0.02	0.24	0.00				0.30	0.30	0.30	
Avail Cap(c_a), veh/h	0	1319		454	694	0				1084	990	992	
HCM Platoon Ratio	1.00	1.00	1.00	1.00	1.00	1.00				1.00	1.00	1.00	
Upstream Filter(I)	0.00	1.00	0.00	1.00	1.00	0.00				1.00	1.00	1.00	
Uniform Delay (d), s/veh	0.0	19.1	0.0	21.1	18.1	0.0				5.1	5.1	5.1	
Incr Delay (d2), s/veh	0.0	0.8	0.0	0.0	0.4	0.0				0.7	0.8	0.8	
Initial Q Delay(d3), s/veh	0.0	0.0	0.0	0.0	0.0	0.0				0.0	0.0	0.0	
%ile BackOfQ(95%),veh/ln	0.0	2.9	0.0	0.1	1.3	0.0				2.0	1.9	1.9	
Unsig. Movement Delay, s/veh													
LnGrp Delay(d), s/veh	0.0	20.0	0.0	21.1	18.5	0.0				5.8	5.9	5.9	
LnGrp LOS		B		C	B					A	A	A	
Approach Vol, veh/h		314			76						917		
Approach Delay, s/veh		20.0			18.7						5.9		
Approach LOS		B			B						A		
Timer - Assigned Phs				4		6			8				
Phs Duration (G+Y+Rc), s				13.5		36.0			13.5				
Change Period (Y+Rc), s				5.5		7.0			5.5				
Max Green Setting (Gmax), s				18.5		29.0			18.5				
Max Q Clear Time (g_c+1), s				6.1		6.4			6.2				
Green Ext Time (p_c), s				1.6		5.5			0.2				

Intersection Summary	
HCM 7th Control Delay, s/veh	10.0
HCM 7th LOS	B

Notes
Unsignalized Delay for [EBR] is excluded from calculations of the approach delay and intersection delay.

2025 PM Peak Hour NO BUILD Conditions - Base Case

Synchro 12 Report
Base syn

Timings
1: W. Frntg Rd & Mountain Rd.

Tierra West, LLC
06/29/2024

	→	↖	←	↓
Lane Group	EBT	WBL	WBT	SBT
Lane Configurations	↔	↖	↗	↕
Traffic Volume (vph)	323	4	74	732
Future Volume (vph)	323	4	74	732
Turn Type	NA	Perm	NA	NA
Protected Phases	4		8	6
Permitted Phases		8		
Detector Phase	4	8	8	6
Switch Phase				
Minimum Initial (s)	8.0	8.0	8.0	16.0
Minimum Split (s)	23.5	23.5	23.5	25.0
Total Split (s)	24.0	24.0	24.0	36.0
Total Split (%)	40.0%	40.0%	40.0%	60.0%
Yellow Time (s)	3.5	3.5	3.5	5.0
All-Red Time (s)	2.0	2.0	2.0	2.0
Lost Time Adjust (s)	0.0	0.0	0.0	0.0
Total Lost Time (s)	5.5	5.5	5.5	7.0
Lead/Lag				
Lead-Lag Optimize?				
Recall Mode	None	None	None	Max

Intersection Summary	
Cycle Length:	60
Actuated Cycle Length:	53.3
Natural Cycle:	50
Control Type:	Actuated-Uncoordinated

Splits and Phases: 1: W. Frntg Rd & Mountain Rd.

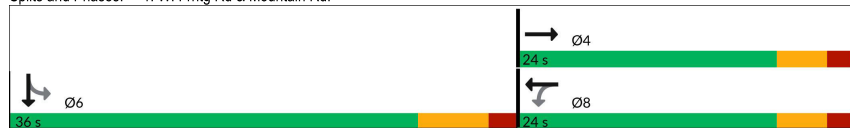

HCM 7th Signalized Intersection Summary
1: W. Frntg Rd & Mountain Rd.

Tierra West, LLC
06/29/2024

	↖	→	↗	↖	←	↖	↗	↖	↗	↖	↗	↖	↗
Movement	EBL	EBT	EBR	WBL	WBT	WBR	NBL	NBT	NBR	SBL	SBT	SBR	
Lane Configurations		↔		↖	↗						↖	↗	
Traffic Volume (veh/h)	0	323	153	4	74	0	0	0	0	24	732	169	
Future Volume (veh/h)	0	323	153	4	74	0	0	0	0	24	732	169	
Initial Q (Qb), veh	0	0	0	0	0	0	0	0	0	0	0	0	
Lane Width Adj.	1.00	1.00	1.00	1.00	1.00	1.00				1.00	1.00	1.00	
Ped-Bike Adj(A_pbT)	1.00	1.00	1.00	1.00	1.00	1.00				1.00	1.00	1.00	
Parking Bus, Adj	1.00	1.00	1.00	1.00	1.00	1.00				1.00	1.00	1.00	
Work Zone On Approach	No					No			No				
Adj Sat Flow, veh/h/ln	0	1856	1856	1856	1856	0				1856	1856	1856	
Adj Flow Rate, veh/h	0	323	0	4	74	0				24	732	169	
Peak Hour Factor	1.00	1.00	1.00	1.00	1.00	1.00				1.00	1.00	1.00	
Percent Heavy Veh. %	0	3	3	3	3	0				3	3	3	
Cap, veh/h	0	568		226	299	0				80	2427	555	
Arrive On Green	0.00	0.16	0.00	0.16	0.16	0.00				0.59	0.59	0.59	
Sat Flow, veh/h	0	3711	0	1048	1856	0				136	4140	946	
Grp Volume(v), veh/h	0	323	0	4	74	0				326	298	301	
Grp Sat Flow(s), veh/h/ln	0	1763	0	1048	1856	0				1849	1689	1685	
Q Serve(g_s), s	0.0	4.2	0.0	0.2	1.7	0.0				4.4	4.4	4.4	
Cycle Q Clear(g_c), s	0.0	4.2	0.0	4.4	1.7	0.0				4.4	4.4	4.4	
Prop In Lane	0.00		0.00	1.00		0.00				0.07		0.56	
Lane Grp Cap(c), veh/h	0	568		226	299	0				1084	990	988	
V/C Ratio(X)	0.00	0.57		0.02	0.25	0.00				0.30	0.30	0.30	
Avail Cap(c_a), veh/h	0	1318		449	694	0				1084	990	988	
HCM Platoon Ratio	1.00	1.00	1.00	1.00	1.00	1.00				1.00	1.00	1.00	
Upstream Filter(I)	0.00	1.00	0.00	1.00	1.00	0.00				1.00	1.00	1.00	
Uniform Delay (d), s/veh	0.0	19.2	0.0	21.2	18.1	0.0				5.1	5.1	5.2	
Incr Delay (d2), s/veh	0.0	0.9	0.0	0.0	0.4	0.0				0.7	0.8	0.8	
Initial Q Delay(d3), s/veh	0.0	0.0	0.0	0.0	0.0	0.0				0.0	0.0	0.0	
%ile BackOfQ(95%),veh/ln	0.0	3.0	0.0	0.1	1.3	0.0				2.1	1.9	1.9	
Unsig. Movement Delay, s/veh													
LnGrp Delay(d), s/veh	0.0	20.1	0.0	21.2	18.6	0.0				5.9	5.9	6.0	
LnGrp LOS		C		C	B					A	A	A	
Approach Vol, veh/h		323			78						925		
Approach Delay, s/veh		20.1			18.7						5.9		
Approach LOS		C			B						A		
Timer - Assigned Phs				4		6			8				
Phs Duration (G+Y+Rc), s				13.5		36.0			13.5				
Change Period (Y+Rc), s				5.5		7.0			5.5				
Max Green Setting (Gmax), s				18.5		29.0			18.5				
Max Q Clear Time (g_c+1), s				6.2		6.4			6.4				
Green Ext Time (p_c), s				1.7		5.6			0.2				

Intersection Summary	
HCM 7th Control Delay, s/veh	10.1
HCM 7th LOS	B

Notes
Unsignalized Delay for [EBR] is excluded from calculations of the approach delay and intersection delay.

Timings
2: W. Frntg Rd & Lomas Blvd.

Tierra West, LLC
06/29/2024

	→	↖	←	↙	↓	↘
Lane Group	EBT	WBL	WBT	SBL	SBT	SBR
Lane Configurations	↑↑↑	↖	↑↑↑	↖	↖↖	↑
Traffic Volume (vph)	836	88	961	756	261	470
Future Volume (vph)	836	88	961	756	261	470
Turn Type	NA	pm+pt	NA	Perm	NA	Perm
Protected Phases	4	3	8		6	
Permitted Phases		8		6		6
Detector Phase	4	3	8	6	6	6
Switch Phase						
Minimum Initial (s)	16.0	3.0	16.0	8.0	8.0	8.0
Minimum Split (s)	23.0	12.5	23.0	24.0	24.0	24.0
Total Split (s)	33.0	16.0	49.0	61.0	61.0	61.0
Total Split (%)	30.0%	14.5%	44.5%	55.5%	55.5%	55.5%
Yellow Time (s)	4.0	4.0	4.0	4.0	4.0	4.0
All-Red Time (s)	1.0	1.0	1.0	2.0	2.0	2.0
Lost Time Adjust (s)	0.0	0.0	0.0	0.0	0.0	0.0
Total Lost Time (s)	5.0	5.0	5.0	6.0	6.0	6.0
Lead/Lag	Lag	Lead				
Lead-Lag Optimize?	Yes	Yes				
Recall Mode	C-Max	None	C-Max	Max	Max	Max

Intersection Summary
 Cycle Length: 110
 Actuated Cycle Length: 110
 Offset: 58.3 (53%), Referenced to phase 4:EBT and 8:WBL, Start of Green
 Natural Cycle: 60
 Control Type: Actuated-Coordinated

Splits and Phases: 2: W. Frntg Rd & Lomas Blvd.



HCM 7th Signalized Intersection Summary
2: W. Frntg Rd & Lomas Blvd.

Tierra West, LLC
06/29/2024

	↖	→	↙	↖	←	↖	↙	↘	↓	↘	↙	↘
Movement	EBL	EBT	EBR	WBL	WBT	WBR	NBL	NBT	NBR	SBL	SBT	SBR
Lane Configurations		↑↑↑		↖	↑↑↑					↖	↖↖	↑
Traffic Volume (veh/h)	0	836	141	88	961	0	0	0	0	756	261	470
Future Volume (veh/h)	0	836	141	88	961	0	0	0	0	756	261	470
Initial Q (Qb), veh	0	0	0	0	0	0	0	0	0	0	0	0
Lane Width Adj.	1.00	1.00	1.00	1.00	1.00	1.00				1.00	1.00	1.00
Ped-Bike Adj(A_pbT)	1.00	1.00	1.00	1.00	1.00	1.00				1.00	1.00	1.00
Parking Bus, Adj	1.00	1.00	1.00	1.00	1.00	1.00				1.00	1.00	1.00
Work Zone On Approach	No				No					No		
Adj Sat Flow, veh/h/ln	0	1856	1856	1856	1856	0				1856	1856	1856
Adj Flow Rate, veh/h	0	836	0	88	961	0				815	413	313
Peak Hour Factor	1.00	1.00	1.00	1.00	1.00	1.00				1.00	1.00	1.00
Percent Heavy Veh. %	0	3	3	3	3	0				3	3	3
Cap, veh/h	0	1552		261	2026	0				1767	928	786
Arrive On Green	0.00	0.31	0.00	0.05	0.40	0.00				0.50	0.50	0.50
Sat Flow, veh/h	0	5400	0	1767	5233	0				3534	1856	1572
Grp Volume(v), veh/h	0	836	0	88	961	0				815	413	313
Grp Sat Flow(s),veh/h/ln	0	1689	0	1767	1689	0				1767	1856	1572
Q Serve(g_s), s	0.0	15.1	0.0	3.6	15.5	0.0				16.5	15.7	13.7
Cycle Q Clear(g_c), s	0.0	15.1	0.0	3.6	15.5	0.0				16.5	15.7	13.7
Prop In Lane	0.00		0.00	1.00		0.00				1.00		1.00
Lane Grp Cap(c), veh/h	0	1552		261	2026	0				1767	928	786
V/C Ratio(X)	0.00	0.54		0.34	0.47	0.00				0.46	0.45	0.40
Avail Cap(c_a), veh/h	0	1552		353	2026	0				1767	928	786
HCM Platoon Ratio	1.00	1.00	1.00	1.00	1.00	1.00				1.00	1.00	1.00
Upstream Filter(I)	0.00	1.00	0.00	1.00	1.00	0.00				0.66	0.66	0.66
Uniform Delay (d), s/veh	0.0	31.7	0.0	24.3	24.4	0.0				17.9	17.7	17.2
Incr Delay (d2), s/veh	0.0	1.3	0.0	0.8	0.8	0.0				0.6	1.0	1.0
Initial Q Delay(d3), s/veh	0.0	0.0	0.0	0.0	0.0	0.0				0.0	0.0	0.0
%ile BackOfQ(95%),veh/ln	0.0	10.4	0.0	2.8	10.4	0.0				9.8	10.0	7.8
Unsig. Movement Delay, s/veh												
LnGrp Delay(d), s/veh	0.0	33.0	0.0	25.1	25.2	0.0				18.4	18.7	18.2
LnGrp LOS		C		C	C					B	B	B
Approach Vol, veh/h		836			1049							1541
Approach Delay, s/veh		33.0			25.2							18.5
Approach LOS		C			C							B
Timer - Assigned Phs		3	4		6		8					
Phs Duration (G+Y+Rc), s		10.3	38.7		61.0		49.0					
Change Period (Y+Rc), s		5.0	5.0		6.0		5.0					
Max Green Setting (Gmax), s		11.0	28.0		55.0		44.0					
Max Q Clear Time (g_c+I1), s		5.6	17.1		18.5		17.5					
Green Ext Time (p_c), s		0.1	4.3		8.0		7.7					

Intersection Summary
 HCM 7th Control Delay, s/veh: 24.1
 HCM 7th LOS: C

Notes
 User approved volume balancing among the lanes for turning movement.
 Unsignalized Delay for [EBR] is excluded from calculations of the approach delay and intersection delay.

Timings
2: W. Frntg Rd & Lomas Blvd.

Tierra West, LLC
06/29/2024

	→	↖	←	↙	↓	↘
Lane Group	EBT	WBL	WBT	SBL	SBT	SBR
Lane Configurations	↑↑↑	↖	↑↑↑	↖	↖↖	↑
Traffic Volume (vph)	837	88	965	756	261	470
Future Volume (vph)	837	88	965	756	261	470
Turn Type	NA	pm+pt	NA	Perm	NA	Perm
Protected Phases	4	3	8		6	
Permitted Phases		8		6		6
Detector Phase	4	3	8	6	6	6
Switch Phase						
Minimum Initial (s)	16.0	3.0	16.0	8.0	8.0	8.0
Minimum Split (s)	23.0	12.5	23.0	24.0	24.0	24.0
Total Split (s)	33.0	16.0	49.0	61.0	61.0	61.0
Total Split (%)	30.0%	14.5%	44.5%	55.5%	55.5%	55.5%
Yellow Time (s)	4.0	4.0	4.0	4.0	4.0	4.0
All-Red Time (s)	1.0	1.0	1.0	2.0	2.0	2.0
Lost Time Adjust (s)	0.0	0.0	0.0	0.0	0.0	0.0
Total Lost Time (s)	5.0	5.0	5.0	6.0	6.0	6.0
Lead/Lag	Lag	Lead				
Lead-Lag Optimize?	Yes	Yes				
Recall Mode	C-Max	None	C-Max	Max	Max	Max

Intersection Summary	
Cycle Length:	110
Actuated Cycle Length:	110
Offset:	58.3 (53%), Referenced to phase 4:EBT and 8:WBL, Start of Green
Natural Cycle:	60
Control Type:	Actuated-Coordinated

Splits and Phases: 2: W. Frntg Rd & Lomas Blvd.



2025 AM Peak Hour BUILD Condition - Base Case

Synchro 12 Report
Base syn

HCM 7th Signalized Intersection Summary
2: W. Frntg Rd & Lomas Blvd.

Tierra West, LLC
06/29/2024

	↖	→	↙	↖	←	↖	↙	↘	↑	↖	↙	↓	↘
Movement	EBL	EBT	EBR	WBL	WBT	WBR	NBL	NBT	NBR	SBL	SBT	SBR	
Lane Configurations		↑↑↑		↖	↑↑↑					↖	↖↖	↑	
Traffic Volume (veh/h)	0	837	141	88	965	0	0	0	0	756	261	470	
Future Volume (veh/h)	0	837	141	88	965	0	0	0	0	756	261	470	
Initial Q (Qb), veh	0	0	0	0	0	0	0	0	0	0	0	0	
Lane Width Adj.	1.00	1.00	1.00	1.00	1.00	1.00				1.00	1.00	1.00	
Ped-Bike Adj(A_pbT)	1.00	1.00	1.00	1.00	1.00	1.00				1.00	1.00	1.00	
Parking Bus, Adj	1.00	1.00	1.00	1.00	1.00	1.00				1.00	1.00	1.00	
Work Zone On Approach	No				No					No			
Adj Sat Flow, veh/h/ln	0	1856	1856	1856	1856	0				1856	1856	1856	
Adj Flow Rate, veh/h	0	837	0	88	965	0				815	413	313	
Peak Hour Factor	1.00	1.00	1.00	1.00	1.00	1.00				1.00	1.00	1.00	
Percent Heavy Veh. %	0	3	3	3	3	0				3	3	3	
Cap, veh/h	0	1552		261	2026	0				1767	928	786	
Arrive On Green	0.00	0.31	0.00	0.05	0.40	0.00				0.50	0.50	0.50	
Sat Flow, veh/h	0	5400	0	1767	5233	0				3534	1856	1572	
Grp Volume(v), veh/h	0	837	0	88	965	0				815	413	313	
Grp Sat Flow(s),veh/h/ln	0	1689	0	1767	1689	0				1767	1856	1572	
Q Serve(g_s), s	0.0	15.1	0.0	3.6	15.5	0.0				16.5	15.7	13.7	
Cycle Q Clear(g_c), s	0.0	15.1	0.0	3.6	15.5	0.0				16.5	15.7	13.7	
Prop In Lane	0.00		0.00	1.00		0.00				1.00		1.00	
Lane Grp Cap(c), veh/h	0	1552		261	2026	0				1767	928	786	
V/C Ratio(X)	0.00	0.54		0.34	0.48	0.00				0.46	0.45	0.40	
Avail Cap(c_a), veh/h	0	1552		352	2026	0				1767	928	786	
HCM Platoon Ratio	1.00	1.00	1.00	1.00	1.00	1.00				1.00	1.00	1.00	
Upstream Filter(I)	0.00	1.00	0.00	1.00	1.00	0.00				0.65	0.65	0.65	
Uniform Delay (d), s/veh	0.0	31.7	0.0	24.3	24.5	0.0				17.9	17.7	17.2	
Incr Delay (d2), s/veh	0.0	1.3	0.0	0.8	0.8	0.0				0.6	1.0	1.0	
Initial Q Delay(d3), s/veh	0.0	0.0	0.0	0.0	0.0	0.0				0.0	0.0	0.0	
%ile BackOfQ(95%),veh/ln	0.0	10.4	0.0	2.8	10.4	0.0				9.8	10.0	7.8	
Unsig. Movement Delay, s/veh													
LnGrp Delay(d), s/veh	0.0	33.1	0.0	25.1	25.3	0.0				18.4	18.7	18.1	
LnGrp LOS		C		C	C					B	B	B	
Approach Vol, veh/h		837			1053							1541	
Approach Delay, s/veh		33.1			25.2							18.4	
Approach LOS		C			C							B	
Timer - Assigned Phs		3	4		6		8						
Phs Duration (G+Y+Rc), s		10.3	38.7		61.0		49.0						
Change Period (Y+Rc), s		5.0	5.0		6.0		5.0						
Max Green Setting (Gmax), s		11.0	28.0		55.0		44.0						
Max Q Clear Time (g_c+I1), s		5.6	17.1		18.5		17.5						
Green Ext Time (p_c), s		0.1	4.3		8.0		7.7						

Intersection Summary	
HCM 7th Control Delay, s/veh	24.1
HCM 7th LOS	C

Notes
User approved volume balancing among the lanes for turning movement.
Unsignalized Delay for [EBR] is excluded from calculations of the approach delay and intersection delay.

2025 AM Peak Hour BUILD Condition - Base Case

Synchro 12 Report
Base syn

Timings
2: W. Frntg Rd & Lomas Blvd.

Tierra West, LLC
06/29/2024

	→	↖	←	↙	↓	↘
Lane Group	EBT	WBL	WBT	SBL	SBT	SBR
Lane Configurations	↑↑↑	↖	↑↑↑	↖	↖	↖
Traffic Volume (vph)	945	209	997	318	330	189
Future Volume (vph)	945	209	997	318	330	189
Turn Type	NA	pm+pt	NA	Perm	NA	Perm
Protected Phases	4	3	8		6	
Permitted Phases		8		6		6
Detector Phase	4	3	8	6	6	6
Switch Phase						
Minimum Initial (s)	16.0	3.0	16.0	8.0	8.0	8.0
Minimum Split (s)	23.0	12.5	23.0	24.0	24.0	24.0
Total Split (s)	49.0	30.0	79.0	41.0	41.0	41.0
Total Split (%)	40.8%	25.0%	65.8%	34.2%	34.2%	34.2%
Yellow Time (s)	4.0	4.0	4.0	4.0	4.0	4.0
All-Red Time (s)	1.0	1.0	1.0	2.0	2.0	2.0
Lost Time Adjust (s)	0.0	0.0	0.0	0.0	0.0	0.0
Total Lost Time (s)	5.0	5.0	5.0	6.0	6.0	6.0
Lead/Lag	Lag	Lead				
Lead-Lag Optimize?	Yes	Yes				
Recall Mode	C-Max	None	C-Max	Max	Max	Max

Intersection Summary

Cycle Length: 120
 Actuated Cycle Length: 120
 Offset: 63.6 (53%), Referenced to phase 4:EBT and 8:WBT, Start of Green
 Natural Cycle: 60
 Control Type: Actuated-Coordinated

Splits and Phases: 2: W. Frntg Rd & Lomas Blvd.

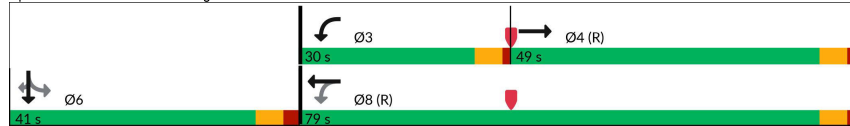

2025 PM Peak Hour NO BUILD Conditions - Base Case

Synchro 12 Report
Base syn

HCM 7th Signalized Intersection Summary
2: W. Frntg Rd & Lomas Blvd.

Tierra West, LLC
06/29/2024

	↖	→	↙	↖	←	↖	↖	↖	↖	↖	↖	↖	↖	↖	↖
Movement	EBL	EBT	EBR	WBL	WBT	WBR	NBL	NBT	NBR	SBL	SBT	SBR			
Lane Configurations		↑↑↑		↖	↑↑↑					↖	↖	↖			
Traffic Volume (veh/h)	0	945	217	209	997	0	0	0	0	318	330	189			
Future Volume (veh/h)	0	945	217	209	997	0	0	0	0	318	330	189			
Initial Q (Qb), veh	0	0	0	0	0	0	0	0	0	0	0	0			
Lane Width Adj.	1.00	1.00	1.00	1.00	1.00	1.00				1.00	1.00	1.00			
Ped-Bike Adj(A_pbT)	1.00	1.00	1.00	1.00	1.00	1.00				1.00	1.00	1.00			
Parking Bus, Adj	1.00	1.00	1.00	1.00	1.00	1.00				1.00	1.00	1.00			
Work Zone On Approach	No				No					No					
Adj Sat Flow, veh/h/ln	0	1856	1856	1856	1856	0				1856	1856	1856			
Adj Flow Rate, veh/h	0	945	0	209	997	0				212	573	126			
Peak Hour Factor	1.00	1.00	1.00	1.00	1.00	1.00				1.00	1.00	1.00			
Percent Heavy Veh. %	0	3	3	3	3	0				3	3	3			
Cap, veh/h	0	2529		420	3124	0				515	1082	459			
Arrive On Green	0.00	0.50	0.00	0.08	0.62	0.00				0.29	0.29	0.29			
Sat Flow, veh/h	0	5400	0	1767	5233	0				1767	3711	1572			
Grp Volume(v), veh/h	0	945	0	209	997	0				212	573	126			
Grp Sat Flow(s),veh/h/ln	0	1689	0	1767	1689	0				1767	1856	1572			
Q Serve(g_s), s	0.0	13.8	0.0	6.6	11.3	0.0				11.6	15.5	7.4			
Cycle Q Clear(g_c), s	0.0	13.8	0.0	6.6	11.3	0.0				11.6	15.5	7.4			
Prop In Lane	0.00		0.00	1.00		0.00				1.00		1.00			
Lane Grp Cap(c), veh/h	0	2529		420	3124	0				515	1082	459			
V/C Ratio(X)	0.00	0.37		0.50	0.32	0.00				0.41	0.53	0.27			
Avail Cap(c_a), veh/h	0	2529		654	3124	0				515	1082	459			
HCM Platoon Ratio	1.00	1.00	1.00	1.00	1.00	1.00				1.00	1.00	1.00			
Upstream Filter(I)	0.00	1.00	0.00	1.00	1.00	0.00				0.95	0.95	0.95			
Uniform Delay (d), s/veh	0.0	18.5	0.0	13.0	11.0	0.0				34.2	35.6	32.7			
Incr Delay (d2), s/veh	0.0	0.4	0.0	0.9	0.3	0.0				2.3	1.8	1.4			
Initial Q Delay(d3), s/veh	0.0	0.0	0.0	0.0	0.0	0.0				0.0	0.0	0.0			
%ile BackOfQ(95%),veh/ln	0.0	9.3	0.0	4.7	7.5	0.0				8.9	11.4	5.3			
Unsig. Movement Delay, s/veh															
LnGrp Delay(d), s/veh	0.0	18.9	0.0	13.9	11.2	0.0				36.5	37.4	34.1			
LnGrp LOS		B		B	B					D	D	C			
Approach Vol, veh/h		945			1206							911			
Approach Delay, s/veh		18.9			11.7							36.7			
Approach LOS		B			B							D			
Timer - Assigned Phs		3		4		6				8					
Phs Duration (G+Y+Rc), s		14.1		64.9		41.0				79.0					
Change Period (Y+Rc), s		5.0		5.0		6.0				5.0					
Max Green Setting (Gmax), s		25.0		44.0		35.0				74.0					
Max Q Clear Time (g_c+I1), s		8.6		15.8		17.5				13.3					
Green Ext Time (p_c), s		0.5		7.6		4.4				9.3					

Intersection Summary

HCM 7th Control Delay, s/veh: 21.4
 HCM 7th LOS: C

Notes

User approved volume balancing among the lanes for turning movement.
 Unsignalized Delay for [EBR] is excluded from calculations of the approach delay and intersection delay.

2025 PM Peak Hour NO BUILD Conditions - Base Case

Synchro 12 Report
Base syn

Timings
2: W. Frntg Rd & Lomas Blvd.

Tierra West, LLC
06/29/2024

	→	↖	←	↙	↓	↘
Lane Group	EBT	WBL	WBT	SBL	SBT	SBR
Lane Configurations	↑↑↑	↖	↑↑↑	↖	↖	↖
Traffic Volume (vph)	948	209	999	321	331	189
Future Volume (vph)	948	209	999	321	331	189
Turn Type	NA	pm+pt	NA	Perm	NA	Perm
Protected Phases	4	3	8		6	
Permitted Phases		8		6		6
Detector Phase	4	3	8	6	6	6
Switch Phase						
Minimum Initial (s)	16.0	3.0	16.0	8.0	8.0	8.0
Minimum Split (s)	23.0	12.5	23.0	24.0	24.0	24.0
Total Split (s)	49.0	30.0	79.0	41.0	41.0	41.0
Total Split (%)	40.8%	25.0%	65.8%	34.2%	34.2%	34.2%
Yellow Time (s)	4.0	4.0	4.0	4.0	4.0	4.0
All-Red Time (s)	1.0	1.0	1.0	2.0	2.0	2.0
Lost Time Adjust (s)	0.0	0.0	0.0	0.0	0.0	0.0
Total Lost Time (s)	5.0	5.0	5.0	6.0	6.0	6.0
Lead/Lag	Lag	Lead				
Lead-Lag Optimize?	Yes	Yes				
Recall Mode	C-Max	None	C-Max	Max	Max	Max

Intersection Summary	
Cycle Length:	120
Actuated Cycle Length:	120
Offset:	63.6 (53%), Referenced to phase 4:EBT and 8:WBT, Start of Green
Natural Cycle:	60
Control Type:	Actuated-Coordinated

Splits and Phases: 2: W. Frntg Rd & Lomas Blvd.

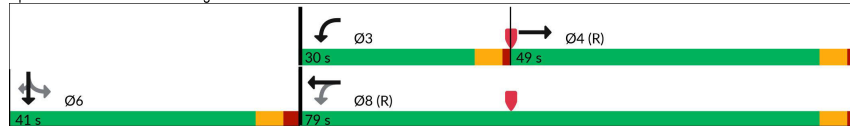

2025 PM Peak Hour BUILD Conditions - Base Case

Synchro 12 Report
Base syn

HCM 7th Signalized Intersection Summary
2: W. Frntg Rd & Lomas Blvd.

Tierra West, LLC
06/29/2024

	↖	→	↙	↖	←	↖	↖	↖	↖	↖	↖	↖	↖	↖
Movement	EBL	EBT	EBR	WBL	WBT	WBR	NBL	NBT	NBR	SBL	SBT	SBR		
Lane Configurations		↑↑↑		↖	↑↑↑					↖	↖	↖		
Traffic Volume (veh/h)	0	948	218	209	999	0	0	0	0	321	331	189		
Future Volume (veh/h)	0	948	218	209	999	0	0	0	0	321	331	189		
Initial Q (Qb), veh	0	0	0	0	0	0	0	0	0	0	0	0		
Lane Width Adj.	1.00	1.00	1.00	1.00	1.00	1.00				1.00	1.00	1.00		
Ped-Bike Adj(A_pbT)	1.00	1.00	1.00	1.00	1.00	1.00				1.00	1.00	1.00		
Parking Bus, Adj	1.00	1.00	1.00	1.00	1.00	1.00				1.00	1.00	1.00		
Work Zone On Approach	No				No					No				
Adj Sat Flow, veh/h/ln	0	1856	1856	1856	1856	0				1856	1856	1856		
Adj Flow Rate, veh/h	0	948	0	209	999	0				214	575	126		
Peak Hour Factor	1.00	1.00	1.00	1.00	1.00	1.00				1.00	1.00	1.00		
Percent Heavy Veh. %	0	3	3	3	3	0				3	3	3		
Cap, veh/h	0	2529		419	3124	0				515	1082	459		
Arrive On Green	0.00	0.50	0.00	0.08	0.62	0.00				0.29	0.29	0.29		
Sat Flow, veh/h	0	5400	0	1767	5233	0				1767	3711	1572		
Grp Volume(v), veh/h	0	948	0	209	999	0				214	575	126		
Grp Sat Flow(s), veh/h/ln	0	1689	0	1767	1689	0				1767	1856	1572		
Q Serve(g_s), s	0.0	13.8	0.0	6.6	11.3	0.0				11.7	15.6	7.4		
Cycle Q Clear(g_c), s	0.0	13.8	0.0	6.6	11.3	0.0				11.7	15.6	7.4		
Prop In Lane	0.00		0.00	1.00		0.00				1.00		1.00		
Lane Grp Cap(c), veh/h	0	2529		419	3124	0				515	1082	459		
V/C Ratio(X)	0.00	0.37		0.50	0.32	0.00				0.42	0.53	0.27		
Avail Cap(c_a), veh/h	0	2529		654	3124	0				515	1082	459		
HCM Platoon Ratio	1.00	1.00	1.00	1.00	1.00	1.00				1.00	1.00	1.00		
Upstream Filter(I)	0.00	1.00	0.00	1.00	1.00	0.00				0.95	0.95	0.95		
Uniform Delay (d), s/veh	0.0	18.5	0.0	13.0	11.0	0.0				34.3	35.6	32.7		
Incr Delay (d2), s/veh	0.0	0.4	0.0	0.9	0.3	0.0				2.3	1.8	1.4		
Initial Q Delay(d3), s/veh	0.0	0.0	0.0	0.0	0.0	0.0				0.0	0.0	0.0		
%ile BackOfQ(95%),veh/ln	0.0	9.3	0.0	4.7	7.5	0.0				8.9	11.4	5.3		
Unsig. Movement Delay, s/veh														
LnGrp Delay(d), s/veh	0.0	18.9	0.0	13.9	11.3	0.0				36.6	37.4	34.1		
LnGrp LOS		B		B	B					D	D	C		
Approach Vol, veh/h		948			1208							915		
Approach Delay, s/veh		18.9			11.7							36.8		
Approach LOS		B			B							D		
Timer - Assigned Phs		3		4		6			8					
Phs Duration (G+Y+Rc), s		14.1		64.9		41.0			79.0					
Change Period (Y+Rc), s		5.0		5.0		6.0			5.0					
Max Green Setting (Gmax), s		25.0		44.0		35.0			74.0					
Max Q Clear Time (g_c+I1), s		8.6		15.8		17.6			13.3					
Green Ext Time (p_c), s		0.5		7.7		4.4			9.3					

Intersection Summary	
HCM 7th Control Delay, s/veh	21.4
HCM 7th LOS	C

Notes
User approved volume balancing among the lanes for turning movement.
Unsignalized Delay for [EBR] is excluded from calculations of the approach delay and intersection delay.

2025 PM Peak Hour BUILD Conditions - Base Case

Synchro 12 Report
Base syn

Intersection												
Int Delay, s/veh	1.2											
Movement	EBL	EBT	EBR	WBL	WBT	WBR	NBL	NBT	NBR	SBL	SBT	SBR
Lane Configurations	↙ ↑↑↑ ↘			↙ ↑↑↑ ↘		↙		↔		↙	↑	↙
Traffic Vol, veh/h	56	913	12	36	1182	129	1	1	1	52	1	32
Future Vol, veh/h	56	913	12	36	1182	129	1	1	1	52	1	32
Conflicting Peds, #/hr	0	0	0	0	0	0	0	0	0	0	0	0
Sign Control	Free	Free	Free	Free	Free	Free	Stop	Stop	Stop	Stop	Stop	Stop
RT Channelized	-	-	None	-	-	None	-	-	None	-	-	None
Storage Length	150	-	-	0	-	350	-	-	-	0	-	250
Veh in Median Storage, #	-	0	-	-	0	-	-	1	-	-	1	-
Grade, %	-	0	-	-	0	-	-	0	-	-	0	-
Peak Hour Factor	100	100	100	100	100	100	100	100	100	100	100	100
Heavy Vehicles, %	3	3	3	3	3	3	3	3	3	3	3	3
Mvmt Flow	56	913	12	36	1182	129	1	1	1	52	1	32

Major/Minor	Major1			Major2			Minor1			Minor2		
Conflicting Flow All	1311	0	0	925	0	0	1576	2414	463	1732	2291	591
Stage 1	-	-	-	-	-	-	1031	1031	-	1254	1254	-
Stage 2	-	-	-	-	-	-	545	1383	-	478	1037	-
Critical Hdwy	5.36	-	-	5.36	-	-	6.46	6.56	7.16	6.46	6.56	7.16
Critical Hdwy Stg 1	-	-	-	-	-	-	7.36	5.56	-	7.36	5.56	-
Critical Hdwy Stg 2	-	-	-	-	-	-	6.76	5.56	-	6.76	5.56	-
Follow-up Hdwy	3.13	-	-	3.13	-	-	3.83	4.03	3.93	3.83	4.03	3.93
Pot Cap-1 Maneuver	535	-	-	422	-	-	*253	55	465	194	69	*731
Stage 1	-	-	-	-	-	-	*188	306	-	387	461	-
Stage 2	-	-	-	-	-	-	*750	390	-	489	304	-
Platoon blocked, %	0	-	-	-	-	-	0	0	-	0	0	0
Mov Cap-1 Maneuver	535	-	-	422	-	-	*197	45	465	158	56	*731
Mov Cap-2 Maneuver	-	-	-	-	-	-	*152	151	-	243	162	-
Stage 1	-	-	-	-	-	-	*168	274	-	354	422	-
Stage 2	-	-	-	-	-	-	*655	357	-	435	273	-

Approach	EB		WB		NB		SB	
HCM Control Delay, s/v	0.71		0.38		23.7		18.72	
HCM LOS					C		C	

Minor Lane/Major Mvmt	NBLn1	EBL	EBT	EBR	WBL	WBT	WBR	SBLn1	SBLn2	SBLn3
Capacity (veh/h)	196	535	-	-	422	-	-	243	162	731
HCM Lane V/C Ratio	0.015	0.105	-	-	0.085	-	-	0.214	0.006	0.044
HCM Control Delay (s/veh)	23.7	12.5	-	-	14.3	-	-	23.8	27.4	10.2
HCM Lane LOS	C	B	-	-	B	-	-	C	D	B
HCM 95th %tile Q(veh)	0	0.3	-	-	0.3	-	-	0.8	0	0.1

Notes
 ~: Volume exceeds capacity \$: Delay exceeds 300s +: Computation Not Defined *: All major volume in platoon

Intersection												
Int Delay, s/veh	1.2											
Movement	EBL	EBT	EBR	WBL	WBT	WBR	NBL	NBT	NBR	SBL	SBT	SBR
Lane Configurations	↖ ↑↑↑			↖ ↑↑↑		↖		↔		↖	↑	↖
Traffic Vol, veh/h	59	913	12	36	1182	133	1	1	1	54	1	33
Future Vol, veh/h	59	913	12	36	1182	133	1	1	1	54	1	33
Conflicting Peds, #/hr	0	0	0	0	0	0	0	0	0	0	0	0
Sign Control	Free	Free	Free	Free	Free	Free	Stop	Stop	Stop	Stop	Stop	Stop
RT Channelized	-	-	None	-	-	None	-	-	None	-	-	None
Storage Length	150	-	-	0	-	350	-	-	-	0	-	250
Veh in Median Storage, #	-	0	-	-	0	-	-	1	-	-	1	-
Grade, %	-	0	-	-	0	-	-	0	-	-	0	-
Peak Hour Factor	100	100	100	100	100	100	100	100	100	100	100	100
Heavy Vehicles, %	3	3	3	3	3	3	3	3	3	3	3	3
Mvmt Flow	59	913	12	36	1182	133	1	1	1	54	1	33

Major/Minor	Major1			Major2			Minor1			Minor2		
Conflicting Flow All	1315	0	0	925	0	0	1582	2424	463	1738	2297	591
Stage 1	-	-	-	-	-	-	1037	1037	-	1254	1254	-
Stage 2	-	-	-	-	-	-	545	1387	-	484	1043	-
Critical Hdwy	5.36	-	-	5.36	-	-	6.46	6.56	7.16	6.46	6.56	7.16
Critical Hdwy Stg 1	-	-	-	-	-	-	7.36	5.56	-	7.36	5.56	-
Critical Hdwy Stg 2	-	-	-	-	-	-	6.76	5.56	-	6.76	5.56	-
Follow-up Hdwy	3.13	-	-	3.13	-	-	3.83	4.03	3.93	3.83	4.03	3.93
Pot Cap-1 Maneuver	532	-	-	422	-	-	*250	54	465	192	68	*731
Stage 1	-	-	-	-	-	-	*186	304	-	387	461	-
Stage 2	-	-	-	-	-	-	*750	388	-	485	302	-
Platoon blocked, %	0	-	-	-	-	-	0	0	-	0	0	0
Mov Cap-1 Maneuver	532	-	-	422	-	-	*193	44	465	155	55	*731
Mov Cap-2 Maneuver	-	-	-	-	-	-	*149	149	-	240	160	-
Stage 1	-	-	-	-	-	-	*166	271	-	354	422	-
Stage 2	-	-	-	-	-	-	*654	355	-	429	269	-

Approach	EB			WB			NB			SB		
HCM Control Delay, s/v	0.76			0.38			23.96			19.02		
HCM LOS							C			C		

Minor Lane/Major Mvmt	NBLn1	EBL	EBT	EBR	WBL	WBT	WBR	SBLn1	SBLn2	SBLn3	
Capacity (veh/h)	193	532	-	-	422	-	-	240	160	731	
HCM Lane V/C Ratio	0.016	0.111	-	-	0.085	-	-	0.225	0.006	0.045	
HCM Control Delay (s/veh)	24	12.6	-	-	14.3	-	-	24.3	27.7	10.2	
HCM Lane LOS		C	B	-	-	B	-	-	C	D	B
HCM 95th %tile Q(veh)		0	0.4	-	-	0.3	-	-	0.8	0	0.1

Notes
 ~: Volume exceeds capacity \$: Delay exceeds 300s +: Computation Not Defined *: All major volume in platoon

Intersection												
Int Delay, s/veh	0.7											
Movement	EBL	EBT	EBR	WBL	WBT	WBR	NBL	NBT	NBR	SBL	SBT	SBR
Lane Configurations	↖ ↗ ↕			↖ ↗ ↕		↖		↕		↖	↗	↖
Traffic Vol, veh/h	24	1182	4	8	1142	56	1	1	16	28	1	56
Future Vol, veh/h	24	1182	4	8	1142	56	1	1	16	28	1	56
Conflicting Peds, #/hr	0	0	0	0	0	0	0	0	0	0	0	0
Sign Control	Free	Free	Free	Free	Free	Free	Stop	Stop	Stop	Stop	Stop	Stop
RT Channelized	-	-	None	-	-	None	-	-	None	-	-	None
Storage Length	150	-	-	0	-	350	-	-	-	0	-	250
Veh in Median Storage, #	-	0	-	-	0	-	-	1	-	-	1	-
Grade, %	-	0	-	-	0	-	-	0	-	-	0	-
Peak Hour Factor	100	100	100	100	100	100	100	100	100	100	100	100
Heavy Vehicles, %	3	3	3	3	3	3	3	3	3	3	3	3
Mvmt Flow	24	1182	4	8	1142	56	1	1	16	28	1	56

Major/Minor	Major1			Major2			Minor1			Minor2		
Conflicting Flow All	1198	0	0	1186	0	0	1705	2446	593	1679	2392	571
Stage 1	-	-	-	-	-	-	1232	1232	-	1158	1158	-
Stage 2	-	-	-	-	-	-	473	1214	-	521	1234	-
Critical Hdwy	5.36	-	-	5.36	-	-	6.46	6.56	7.16	6.46	6.56	7.16
Critical Hdwy Stg 1	-	-	-	-	-	-	7.36	5.56	-	7.36	5.56	-
Critical Hdwy Stg 2	-	-	-	-	-	-	6.76	5.56	-	6.76	5.56	-
Follow-up Hdwy	3.13	-	-	3.13	-	-	3.83	4.03	3.93	3.83	4.03	3.93
Pot Cap-1 Maneuver	623	-	-	315	-	-	*203	52	383	212	57	*731
Stage 1	-	-	-	-	-	-	*136	246	-	464	521	-
Stage 2	-	-	-	-	-	-	*750	485	-	460	245	-
Platoon blocked, %	0	-	-	-	-	-	0	0	-	0	0	0
Mov Cap-1 Maneuver	623	-	-	315	-	-	*174	49	383	189	54	*731
Mov Cap-2 Maneuver	-	-	-	-	-	-	*115	161	-	283	164	-
Stage 1	-	-	-	-	-	-	*131	236	-	453	507	-
Stage 2	-	-	-	-	-	-	*674	472	-	422	236	-

Approach	EB	WB	NB	SB
HCM Control Delay, s/v	0.22	0.11	17.02	13.41
HCM LOS			C	B

Minor Lane/Major Mvmt	NBLn1	EBL	EBT	EBR	WBL	WBT	WBR	SBLn1	SBLn2	SBLn3
Capacity (veh/h)	317	623	-	-	315	-	-	283	164	731
HCM Lane V/C Ratio	0.057	0.039	-	-	0.025	-	-	0.099	0.006	0.077
HCM Control Delay (s/veh)	17	11	-	-	16.7	-	-	19.1	27.1	10.3
HCM Lane LOS	C	B	-	-	C	-	-	C	D	B
HCM 95th %tile Q(veh)	0.2	0.1	-	-	0.1	-	-	0.3	0	0.2

Notes
 ~: Volume exceeds capacity \$: Delay exceeds 300s +: Computation Not Defined *: All major volume in platoon

Intersection												
Int Delay, s/veh	0.8											
Movement	EBL	EBT	EBR	WBL	WBT	WBR	NBL	NBT	NBR	SBL	SBT	SBR
Lane Configurations	↖ ↗ ↘			↖ ↗ ↘		↖		↔		↖	↗	↘
Traffic Vol, veh/h	26	1182	4	8	1142	58	1	1	16	32	1	59
Future Vol, veh/h	26	1182	4	8	1142	58	1	1	16	32	1	59
Conflicting Peds, #/hr	0	0	0	0	0	0	0	0	0	0	0	0
Sign Control	Free	Free	Free	Free	Free	Free	Stop	Stop	Stop	Stop	Stop	Stop
RT Channelized	-	-	None	-	-	None	-	-	None	-	-	None
Storage Length	150	-	-	0	-	350	-	-	-	0	-	250
Veh in Median Storage, #	-	0	-	-	0	-	-	1	-	-	1	-
Grade, %	-	0	-	-	0	-	-	0	-	-	0	-
Peak Hour Factor	100	100	100	100	100	100	100	100	100	100	100	100
Heavy Vehicles, %	3	3	3	3	3	3	3	3	3	3	3	3
Mvmt Flow	26	1182	4	8	1142	58	1	1	16	32	1	59

Major/Minor	Major1			Major2			Minor1			Minor2		
Conflicting Flow All	1200	0	0	1186	0	0	1709	2452	593	1683	2396	571
Stage 1	-	-	-	-	-	-	1236	1236	-	1158	1158	-
Stage 2	-	-	-	-	-	-	473	1216	-	525	1238	-
Critical Hdwy	5.36	-	-	5.36	-	-	6.46	6.56	7.16	6.46	6.56	7.16
Critical Hdwy Stg 1	-	-	-	-	-	-	7.36	5.56	-	7.36	5.56	-
Critical Hdwy Stg 2	-	-	-	-	-	-	6.76	5.56	-	6.76	5.56	-
Follow-up Hdwy	3.13	-	-	3.13	-	-	3.83	4.03	3.93	3.83	4.03	3.93
Pot Cap-1 Maneuver	621	-	-	315	-	-	*201	51	383	210	57	*731
Stage 1	-	-	-	-	-	-	*135	245	-	464	521	-
Stage 2	-	-	-	-	-	-	*750	483	-	458	244	-
Platoon blocked, %	0	-	-	-	-	-	0	0	-	0	0	0
Mov Cap-1 Maneuver	621	-	-	315	-	-	*172	48	383	187	53	*731
Mov Cap-2 Maneuver	-	-	-	-	-	-	*114	160	-	281	163	-
Stage 1	-	-	-	-	-	-	*129	234	-	453	507	-
Stage 2	-	-	-	-	-	-	*671	471	-	418	234	-

Approach	EB			WB			NB			SB		
HCM Control Delay, s/v	0.24			0.11			17.05			13.69		
HCM LOS							C			B		

Minor Lane/Major Mvmt	NBLn1	EBL	EBT	EBR	WBL	WBT	WBR	SBLn1	SBLn2	SBLn3
Capacity (veh/h)	317	621	-	-	315	-	-	281	163	731
HCM Lane V/C Ratio	0.057	0.042	-	-	0.025	-	-	0.114	0.006	0.081
HCM Control Delay (s/veh)	17.1	11	-	-	16.7	-	-	19.4	27.3	10.4
HCM Lane LOS	C	B	-	-	C	-	-	C	D	B
HCM 95th %tile Q(veh)	0.2	0.1	-	-	0.1	-	-	0.4	0	0.3

Notes
 ~: Volume exceeds capacity \$: Delay exceeds 300s +: Computation Not Defined *: All major volume in platoon

Intersection						
Int Delay, s/veh	2.4					
Movement	EBT	EBR	WBL	WBT	NBL	NBR
Lane Configurations	↔		↔	↑	↔	↔
Traffic Vol, veh/h	177	48	101	486	44	52
Future Vol, veh/h	177	48	101	486	44	52
Conflicting Peds, #/hr	0	0	0	0	0	0
Sign Control	Free	Free	Free	Free	Stop	Stop
RT Channelized	-	None	-	None	-	None
Storage Length	-	-	0	-	0	0
Veh in Median Storage, #	0	-	-	0	0	-
Grade, %	0	-	-	0	0	-
Peak Hour Factor	100	100	100	100	100	100
Heavy Vehicles, %	3	3	3	3	3	3
Mvmt Flow	177	48	101	486	44	52

Major/Minor	Major1	Major2	Minor1		
Conflicting Flow All	0	0	225	0	889 201
Stage 1	-	-	-	-	201 -
Stage 2	-	-	-	-	688 -
Critical Hdwy	-	-	4.13	-	6.43 6.23
Critical Hdwy Stg 1	-	-	-	-	5.43 -
Critical Hdwy Stg 2	-	-	-	-	5.43 -
Follow-up Hdwy	-	-	2.227	-	3.527 3.327
Pot Cap-1 Maneuver	-	-	1338	-	312 837
Stage 1	-	-	-	-	830 -
Stage 2	-	-	-	-	497 -
Platoon blocked, %	-	-	-	-	-
Mov Cap-1 Maneuver	-	-	1338	-	289 837
Mov Cap-2 Maneuver	-	-	-	-	289 -
Stage 1	-	-	-	-	830 -
Stage 2	-	-	-	-	460 -

Approach	EB	WB	NB
HCM Control Delay, s/v	0	1.36	14.22
HCM LOS			B

Minor Lane/Major Mvmt	NBLn1	NBLn2	EBT	EBR	WBL	WBT
Capacity (veh/h)	289	837	-	-	1338	-
HCM Lane V/C Ratio	0.152	0.062	-	-	0.076	-
HCM Control Delay (s/veh)	19.7	9.6	-	-	7.9	-
HCM Lane LOS	C	A	-	-	A	-
HCM 95th %tile Q(veh)	0.5	0.2	-	-	0.2	-

Intersection						
Int Delay, s/veh	2.6					
Movement	EBT	EBR	WBL	WBT	NBL	NBR
Lane Configurations	↔		↔	↑	↔	↔
Traffic Vol, veh/h	179	48	118	486	45	52
Future Vol, veh/h	179	48	118	486	45	52
Conflicting Peds, #/hr	0	0	0	0	0	0
Sign Control	Free	Free	Free	Free	Stop	Stop
RT Channelized	-	None	-	None	-	None
Storage Length	-	-	0	-	0	0
Veh in Median Storage, #	0	-	-	0	0	-
Grade, %	0	-	-	0	0	-
Peak Hour Factor	100	100	100	100	100	100
Heavy Vehicles, %	3	3	3	3	3	3
Mvmt Flow	179	48	118	486	45	52

Major/Minor	Major1	Major2	Minor1		
Conflicting Flow All	0	0	227	0	925 203
Stage 1	-	-	-	-	203 -
Stage 2	-	-	-	-	722 -
Critical Hdwy	-	-	4.13	-	6.43 6.23
Critical Hdwy Stg 1	-	-	-	-	5.43 -
Critical Hdwy Stg 2	-	-	-	-	5.43 -
Follow-up Hdwy	-	-	2.227	-	3.527 3.327
Pot Cap-1 Maneuver	-	-	1335	-	297 835
Stage 1	-	-	-	-	829 -
Stage 2	-	-	-	-	479 -
Platoon blocked, %	-	-	-	-	-
Mov Cap-1 Maneuver	-	-	1335	-	271 835
Mov Cap-2 Maneuver	-	-	-	-	271 -
Stage 1	-	-	-	-	829 -
Stage 2	-	-	-	-	437 -

Approach	EB	WB	NB
HCM Control Delay, s/v	0	1.55	14.84
HCM LOS			B

Minor Lane/Major Mvmt	NBLn1	NBLn2	EBT	EBR	WBL	WBT
Capacity (veh/h)	271	835	-	-	1335	-
HCM Lane V/C Ratio	0.166	0.062	-	-	0.088	-
HCM Control Delay (s/veh)	20.9	9.6	-	-	8	-
HCM Lane LOS	C	A	-	-	A	-
HCM 95th %tile Q(veh)	0.6	0.2	-	-	0.3	-

Intersection						
Int Delay, s/veh	3					
Movement	EBT	EBR	WBL	WBT	NBL	NBR
Lane Configurations	↔		↔	↑	↔	↔
Traffic Vol, veh/h	117	4	24	354	68	96
Future Vol, veh/h	117	4	24	354	68	96
Conflicting Peds, #/hr	0	0	0	0	0	0
Sign Control	Free	Free	Free	Free	Stop	Stop
RT Channelized	-	None	-	None	-	None
Storage Length	-	-	0	-	0	0
Veh in Median Storage, #	0	-	-	0	0	-
Grade, %	0	-	-	0	0	-
Peak Hour Factor	100	100	100	100	100	100
Heavy Vehicles, %	3	3	3	3	3	3
Mvmt Flow	117	4	24	354	68	96

Major/Minor	Major1	Major2	Minor1		
Conflicting Flow All	0	0	121	0	521 119
Stage 1	-	-	-	-	119 -
Stage 2	-	-	-	-	402 -
Critical Hdwy	-	-	4.13	-	6.43 6.23
Critical Hdwy Stg 1	-	-	-	-	5.43 -
Critical Hdwy Stg 2	-	-	-	-	5.43 -
Follow-up Hdwy	-	-	2.227	-	3.527 3.327
Pot Cap-1 Maneuver	-	-	1460	-	514 930
Stage 1	-	-	-	-	904 -
Stage 2	-	-	-	-	673 -
Platoon blocked, %	-	-	-	-	-
Mov Cap-1 Maneuver	-	-	1460	-	505 930
Mov Cap-2 Maneuver	-	-	-	-	505 -
Stage 1	-	-	-	-	904 -
Stage 2	-	-	-	-	662 -

Approach	EB	WB	NB
HCM Control Delay, s/v	0	0.48	10.94
HCM LOS			B

Minor Lane/Major Mvmt	NBLn1	NBLn2	EBT	EBR	WBL	WBT
Capacity (veh/h)	505	930	-	-	1460	-
HCM Lane V/C Ratio	0.135	0.103	-	-	0.016	-
HCM Control Delay (s/veh)	13.2	9.3	-	-	7.5	-
HCM Lane LOS	B	A	-	-	A	-
HCM 95th %tile Q(veh)	0.5	0.3	-	-	0.1	-

Intersection						
Int Delay, s/veh	3.1					
Movement	EBT	EBR	WBL	WBT	NBL	NBR
Lane Configurations	↔		↔	↑	↔	↔
Traffic Vol, veh/h	118	4	33	354	70	97
Future Vol, veh/h	118	4	33	354	70	97
Conflicting Peds, #/hr	0	0	0	0	0	0
Sign Control	Free	Free	Free	Free	Stop	Stop
RT Channelized	-	None	-	None	-	None
Storage Length	-	-	0	-	0	0
Veh in Median Storage, #	0	-	-	0	0	-
Grade, %	0	-	-	0	0	-
Peak Hour Factor	100	100	100	100	100	100
Heavy Vehicles, %	3	3	3	3	3	3
Mvmt Flow	118	4	33	354	70	97

Major/Minor	Major1	Major2	Minor1		
Conflicting Flow All	0	0	122	0	540 120
Stage 1	-	-	-	-	120 -
Stage 2	-	-	-	-	420 -
Critical Hdwy	-	-	4.13	-	6.43 6.23
Critical Hdwy Stg 1	-	-	-	-	5.43 -
Critical Hdwy Stg 2	-	-	-	-	5.43 -
Follow-up Hdwy	-	-	2.227	-	3.527 3.327
Pot Cap-1 Maneuver	-	-	1459	-	501 929
Stage 1	-	-	-	-	903 -
Stage 2	-	-	-	-	661 -
Platoon blocked, %	-	-	-	-	-
Mov Cap-1 Maneuver	-	-	1459	-	490 929
Mov Cap-2 Maneuver	-	-	-	-	490 -
Stage 1	-	-	-	-	903 -
Stage 2	-	-	-	-	646 -

Approach	EB	WB	NB
HCM Control Delay, s/v	0	0.64	11.11
HCM LOS			B

Minor Lane/Major Mvmt	NBLn1	NBLn2	EBT	EBR	WBL	WBT
Capacity (veh/h)	490	929	-	-	1459	-
HCM Lane V/C Ratio	0.143	0.104	-	-	0.023	-
HCM Control Delay (s/veh)	13.6	9.3	-	-	7.5	-
HCM Lane LOS	B	A	-	-	A	-
HCM 95th %tile Q(veh)	0.5	0.3	-	-	0.1	-

Intersection						
Int Delay, s/veh	4.9					
Movement	EBL	EBT	WBT	WBR	SBL	SBR
Lane Configurations	↙	↑	↘		↘	↙
Traffic Vol, veh/h	76	193	233	205	109	109
Future Vol, veh/h	76	193	233	205	109	109
Conflicting Peds, #/hr	0	0	0	0	0	0
Sign Control	Free	Free	Free	Free	Stop	Stop
RT Channelized	-	None	-	None	-	None
Storage Length	25	-	-	-	0	-
Veh in Median Storage, #	-	0	0	-	0	-
Grade, %	-	0	0	-	0	-
Peak Hour Factor	100	100	100	100	100	100
Heavy Vehicles, %	3	3	3	3	3	3
Mvmt Flow	76	193	233	205	109	109

Major/Minor	Major1	Major2	Minor2		
Conflicting Flow All	438	0	-	0	681 336
Stage 1	-	-	-	-	336 -
Stage 2	-	-	-	-	345 -
Critical Hdwy	4.13	-	-	-	6.43 6.23
Critical Hdwy Stg 1	-	-	-	-	5.43 -
Critical Hdwy Stg 2	-	-	-	-	5.43 -
Follow-up Hdwy	2.227	-	-	-	3.527 3.327
Pot Cap-1 Maneuver	1117	-	-	-	415 704
Stage 1	-	-	-	-	722 -
Stage 2	-	-	-	-	715 -
Platoon blocked, %		-	-	-	
Mov Cap-1 Maneuver	1117	-	-	-	387 704
Mov Cap-2 Maneuver	-	-	-	-	387 -
Stage 1	-	-	-	-	673 -
Stage 2	-	-	-	-	715 -

Approach	EB	WB	SB
HCM Control Delay, s/v	2.39	0	17.69
HCM LOS			C

Minor Lane/Major Mvmt	EBL	EBT	WBT	WBR	SBLn1
Capacity (veh/h)	1117	-	-	-	499
HCM Lane V/C Ratio	0.068	-	-	-	0.437
HCM Control Delay (s/veh)	8.5	-	-	-	17.7
HCM Lane LOS	A	-	-	-	C
HCM 95th %tile Q(veh)	0.2	-	-	-	2.2

Intersection						
Int Delay, s/veh	4.9					
Movement	EBL	EBT	WBT	WBR	SBL	SBR
Lane Configurations	↙	↑	↘		↘	↙
Traffic Vol, veh/h	76	195	234	205	109	109
Future Vol, veh/h	76	195	234	205	109	109
Conflicting Peds, #/hr	0	0	0	0	0	0
Sign Control	Free	Free	Free	Free	Stop	Stop
RT Channelized	-	None	-	None	-	None
Storage Length	25	-	-	-	0	-
Veh in Median Storage, #	-	0	0	-	0	-
Grade, %	-	0	0	-	0	-
Peak Hour Factor	100	100	100	100	100	100
Heavy Vehicles, %	3	3	3	3	3	3
Mvmt Flow	76	195	234	205	109	109

Major/Minor	Major1	Major2	Minor2		
Conflicting Flow All	439	0	-	0	684 337
Stage 1	-	-	-	-	337 -
Stage 2	-	-	-	-	347 -
Critical Hdwy	4.13	-	-	-	6.43 6.23
Critical Hdwy Stg 1	-	-	-	-	5.43 -
Critical Hdwy Stg 2	-	-	-	-	5.43 -
Follow-up Hdwy	2.227	-	-	-	3.527 3.327
Pot Cap-1 Maneuver	1116	-	-	-	413 703
Stage 1	-	-	-	-	721 -
Stage 2	-	-	-	-	713 -
Platoon blocked, %		-	-	-	
Mov Cap-1 Maneuver	1116	-	-	-	385 703
Mov Cap-2 Maneuver	-	-	-	-	385 -
Stage 1	-	-	-	-	672 -
Stage 2	-	-	-	-	713 -

Approach	EB	WB	SB
HCM Control Delay, s/v	2.37	0	17.76
HCM LOS			C

Minor Lane/Major Mvmt	EBL	EBT	WBT	WBR	SBLn1
Capacity (veh/h)	1116	-	-	-	498
HCM Lane V/C Ratio	0.068	-	-	-	0.438
HCM Control Delay (s/veh)	8.5	-	-	-	17.8
HCM Lane LOS	A	-	-	-	C
HCM 95th %tile Q(veh)	0.2	-	-	-	2.2

Intersection						
Int Delay, s/veh	8.7					
Movement	EBL	EBT	WBT	WBR	SBL	SBR
Lane Configurations	↙	↑	↘		↘	
Traffic Vol, veh/h	20	133	233	44	201	185
Future Vol, veh/h	20	133	233	44	201	185
Conflicting Peds, #/hr	0	0	0	0	0	0
Sign Control	Free	Free	Free	Free	Stop	Stop
RT Channelized	-	None	-	None	-	None
Storage Length	25	-	-	-	0	-
Veh in Median Storage, #	-	0	0	-	0	-
Grade, %	-	0	0	-	0	-
Peak Hour Factor	100	100	100	100	100	100
Heavy Vehicles, %	3	3	3	3	3	3
Mvmt Flow	20	133	233	44	201	185

Major/Minor	Major1	Major2	Minor2		
Conflicting Flow All	277	0	-	0	428 255
Stage 1	-	-	-	-	255 -
Stage 2	-	-	-	-	173 -
Critical Hdwy	4.13	-	-	-	6.43 6.23
Critical Hdwy Stg 1	-	-	-	-	5.43 -
Critical Hdwy Stg 2	-	-	-	-	5.43 -
Follow-up Hdwy	2.227	-	-	-	3.527 3.327
Pot Cap-1 Maneuver	1280	-	-	-	582 781
Stage 1	-	-	-	-	785 -
Stage 2	-	-	-	-	855 -
Platoon blocked, %		-	-	-	
Mov Cap-1 Maneuver	1280	-	-	-	573 781
Mov Cap-2 Maneuver	-	-	-	-	573 -
Stage 1	-	-	-	-	773 -
Stage 2	-	-	-	-	855 -

Approach	EB	WB	SB
HCM Control Delay, s/v	1.03	0	17.99
HCM LOS			C

Minor Lane/Major Mvmt	EBL	EBT	WBT	WBR	SBLn1
Capacity (veh/h)	1280	-	-	-	657
HCM Lane V/C Ratio	0.016	-	-	-	0.588
HCM Control Delay (s/veh)	7.9	-	-	-	18
HCM Lane LOS	A	-	-	-	C
HCM 95th %tile Q(veh)	0	-	-	-	3.8

Intersection						
Int Delay, s/veh	8.7					
Movement	EBL	EBT	WBT	WBR	SBL	SBR
Lane Configurations	↙	↑	↘		↘	
Traffic Vol, veh/h	20	134	235	44	201	185
Future Vol, veh/h	20	134	235	44	201	185
Conflicting Peds, #/hr	0	0	0	0	0	0
Sign Control	Free	Free	Free	Free	Stop	Stop
RT Channelized	-	None	-	None	-	None
Storage Length	25	-	-	-	0	-
Veh in Median Storage, #	-	0	0	-	0	-
Grade, %	-	0	0	-	0	-
Peak Hour Factor	100	100	100	100	100	100
Heavy Vehicles, %	3	3	3	3	3	3
Mvmt Flow	20	134	235	44	201	185

Major/Minor	Major1	Major2	Minor2		
Conflicting Flow All	279	0	-	0	431 257
Stage 1	-	-	-	-	257 -
Stage 2	-	-	-	-	174 -
Critical Hdwy	4.13	-	-	-	6.43 6.23
Critical Hdwy Stg 1	-	-	-	-	5.43 -
Critical Hdwy Stg 2	-	-	-	-	5.43 -
Follow-up Hdwy	2.227	-	-	-	3.527 3.327
Pot Cap-1 Maneuver	1278	-	-	-	579 779
Stage 1	-	-	-	-	784 -
Stage 2	-	-	-	-	854 -
Platoon blocked, %		-	-	-	
Mov Cap-1 Maneuver	1278	-	-	-	570 779
Mov Cap-2 Maneuver	-	-	-	-	570 -
Stage 1	-	-	-	-	771 -
Stage 2	-	-	-	-	854 -

Approach	EB	WB	SB
HCM Control Delay, s/v	1.02	0	18.1
HCM LOS			C

Minor Lane/Major Mvmt	EBL	EBT	WBT	WBR	SBLn1
Capacity (veh/h)	1278	-	-	-	654
HCM Lane V/C Ratio	0.016	-	-	-	0.59
HCM Control Delay (s/veh)	7.9	-	-	-	18.1
HCM Lane LOS	A	-	-	-	C
HCM 95th %tile Q(veh)	0	-	-	-	3.9

Intersection												
Int Delay, s/veh	0.1											
Movement	EBL	EBT	EBR	WBL	WBT	WBR	NBL	NBT	NBR	SBL	SBT	SBR
Lane Configurations	↖	↗			↘				↖		↔	
Traffic Vol, veh/h	1	229	0	0	567	1	0	0	0	2	0	2
Future Vol, veh/h	1	229	0	0	567	1	0	0	0	2	0	2
Conflicting Peds, #/hr	0	0	0	0	0	0	0	0	0	0	0	0
Sign Control	Free	Free	Free	Free	Free	Free	Stop	Stop	Stop	Stop	Stop	Stop
RT Channelized	-	-	None	-	-	None	-	-	None	-	-	None
Storage Length	0	-	-	-	-	-	-	-	0	-	-	-
Veh in Median Storage, #	-	0	-	-	0	-	-	0	-	-	0	-
Grade, %	-	0	-	-	0	-	-	0	-	-	0	-
Peak Hour Factor	100	100	100	100	100	100	100	100	100	100	100	100
Heavy Vehicles, %	3	3	3	3	3	3	3	3	3	3	3	3
Mvmt Flow	1	229	0	0	567	1	0	0	0	2	0	2

Major/Minor	Major1			Major2			Minor1			Minor2		
Conflicting Flow All	568	0	0	-	-	0	-	-	229	799	799	568
Stage 1	-	-	-	-	-	-	-	-	-	568	568	-
Stage 2	-	-	-	-	-	-	-	-	-	231	231	-
Critical Hdwy	4.13	-	-	-	-	-	-	-	6.23	7.13	6.53	6.23
Critical Hdwy Stg 1	-	-	-	-	-	-	-	-	-	6.13	5.53	-
Critical Hdwy Stg 2	-	-	-	-	-	-	-	-	-	6.13	5.53	-
Follow-up Hdwy	2.227	-	-	-	-	-	-	-	3.327	3.527	4.027	3.327
Pot Cap-1 Maneuver	999	-	-	0	-	0	0	0	808	303	318	521
Stage 1	-	-	-	0	-	0	0	0	-	506	505	-
Stage 2	-	-	-	0	-	0	0	0	-	770	711	-
Platoon blocked, %		-	-	-	-							
Mov Cap-1 Maneuver	999	-	-	-	-	-	-	-	808	302	317	521
Mov Cap-2 Maneuver	-	-	-	-	-	-	-	-	-	405	406	-
Stage 1	-	-	-	-	-	-	-	-	-	506	505	-
Stage 2	-	-	-	-	-	-	-	-	-	769	711	-

Approach	EB	WB	NB	SB
HCM Control Delay, s/v	0.04	0	0	12.97
HCM LOS			A	B

Minor Lane/Major Mvmt	NBLn1	EBL	EBT	EBR	WBT	WBR	SBLn1
Capacity (veh/h)	-	999	-	-	-	-	456
HCM Lane V/C Ratio	-	0.001	-	-	-	-	0.009
HCM Control Delay (s/veh)	0	8.6	-	-	-	-	13
HCM Lane LOS		A	A	-	-	-	B
HCM 95th %tile Q(veh)	-	0	-	-	-	-	0

Intersection												
Int Delay, s/veh	0.1											
Movement	EBL	EBT	EBR	WBL	WBT	WBR	NBL	NBT	NBR	SBL	SBT	SBR
Lane Configurations	↖	↗			↗				↖	↔	↔	
Traffic Vol, veh/h	1	229	2	0	584	1	0	0	4	2	0	2
Future Vol, veh/h	1	229	2	0	584	1	0	0	4	2	0	2
Conflicting Peds, #/hr	0	0	0	0	0	0	0	0	0	0	0	0
Sign Control	Free	Free	Free	Free	Free	Free	Stop	Stop	Stop	Stop	Stop	Stop
RT Channelized	-	-	None	-	-	None	-	-	None	-	-	None
Storage Length	0	-	-	-	-	-	-	-	0	-	-	-
Veh in Median Storage, #	-	0	-	-	0	-	-	0	-	-	0	-
Grade, %	-	0	-	-	0	-	-	0	-	-	0	-
Peak Hour Factor	100	100	100	100	100	100	100	100	100	100	100	100
Heavy Vehicles, %	3	3	3	3	3	3	3	3	3	3	3	3
Mvmt Flow	1	229	2	0	584	1	0	0	4	2	0	2

Major/Minor	Major1			Major2			Minor1			Minor2		
Conflicting Flow All	585	0	0	-	-	0	-	-	230	816	818	585
Stage 1	-	-	-	-	-	-	-	-	-	585	585	-
Stage 2	-	-	-	-	-	-	-	-	-	231	233	-
Critical Hdwy	4.13	-	-	-	-	-	-	-	6.23	7.13	6.53	6.23
Critical Hdwy Stg 1	-	-	-	-	-	-	-	-	-	6.13	5.53	-
Critical Hdwy Stg 2	-	-	-	-	-	-	-	-	-	6.13	5.53	-
Follow-up Hdwy	2.227	-	-	-	-	-	-	-	3.327	3.527	4.027	3.327
Pot Cap-1 Maneuver	985	-	-	0	-	0	0	0	807	295	310	509
Stage 1	-	-	-	0	-	0	0	0	-	496	496	-
Stage 2	-	-	-	0	-	0	0	0	-	770	710	-
Platoon blocked, %		-	-	-	-							
Mov Cap-1 Maneuver	985	-	-	-	-	-	-	-	807	293	309	509
Mov Cap-2 Maneuver	-	-	-	-	-	-	-	-	-	397	399	-
Stage 1	-	-	-	-	-	-	-	-	-	496	496	-
Stage 2	-	-	-	-	-	-	-	-	-	765	709	-

Approach	EB	WB	NB	SB
HCM Control Delay, s/v	0.04	0	9.48	13.14
HCM LOS			A	B

Minor Lane/Major Mvmt	NBLn1	EBL	EBT	EBR	WBT	WBR	SBLn1
Capacity (veh/h)	807	985	-	-	-	-	446
HCM Lane V/C Ratio	0.005	0.001	-	-	-	-	0.009
HCM Control Delay (s/veh)	9.5	8.7	-	-	-	-	13.1
HCM Lane LOS	A	A	-	-	-	-	B
HCM 95th %tile Q(veh)	0	0	-	-	-	-	0

Intersection												
Int Delay, s/veh	0.1											
Movement	EBL	EBT	EBR	WBL	WBT	WBR	NBL	NBT	NBR	SBL	SBT	SBR
Lane Configurations	↖	↗			↗				↖		↔	
Traffic Vol, veh/h	1	362	0	0	281	1	0	0	0	4	0	4
Future Vol, veh/h	1	362	0	0	281	1	0	0	0	4	0	4
Conflicting Peds, #/hr	0	0	0	0	0	0	0	0	0	0	0	0
Sign Control	Free	Free	Free	Free	Free	Free	Stop	Stop	Stop	Stop	Stop	Stop
RT Channelized	-	-	None	-	-	None	-	-	None	-	-	None
Storage Length	0	-	-	-	-	-	-	-	0	-	-	-
Veh in Median Storage, #	-	0	-	-	0	-	-	0	-	-	0	-
Grade, %	-	0	-	-	0	-	-	0	-	-	0	-
Peak Hour Factor	100	100	100	100	100	100	100	100	100	100	100	100
Heavy Vehicles, %	3	3	3	3	3	3	3	3	3	3	3	3
Mvmt Flow	1	362	0	0	281	1	0	0	0	4	0	4

Major/Minor	Major1	Major2	Minor1	Minor2
Conflicting Flow All	282	0	0	-
Stage 1	-	-	-	-
Stage 2	-	-	-	-
Critical Hdwy	4.13	-	-	-
Critical Hdwy Stg 1	-	-	-	-
Critical Hdwy Stg 2	-	-	-	-
Follow-up Hdwy	2.227	-	-	-
Pot Cap-1 Maneuver	1275	-	0	-
Stage 1	-	-	0	-
Stage 2	-	-	0	-
Platoon blocked, %	-	-	-	-
Mov Cap-1 Maneuver	1275	-	-	-
Mov Cap-2 Maneuver	-	-	-	-
Stage 1	-	-	-	-
Stage 2	-	-	-	-

Approach	EB	WB	NB	SB
HCM Control Delay, s/v	0.02	0	0	11.16
HCM LOS			A	B

Minor Lane/Major Mvmt	NBLn1	EBL	EBT	EBR	WBT	WBR	SBLn1
Capacity (veh/h)	-	1275	-	-	-	-	592
HCM Lane V/C Ratio	-	0.001	-	-	-	-	0.014
HCM Control Delay (s/veh)	0	7.8	-	-	-	-	11.2
HCM Lane LOS	A	A	-	-	-	-	B
HCM 95th %tile Q(veh)	-	0	-	-	-	-	0

Intersection												
Int Delay, s/veh	0.3											
Movement	EBL	EBT	EBR	WBL	WBT	WBR	NBL	NBT	NBR	SBL	SBT	SBR
Lane Configurations	↖	↗			↖				↖		↔	
Traffic Vol, veh/h	1	363	1	0	290	0	0	0	12	4	0	4
Future Vol, veh/h	1	363	1	0	290	0	0	0	12	4	0	4
Conflicting Peds, #/hr	0	0	0	0	0	0	0	0	0	0	0	0
Sign Control	Free	Free	Free	Free	Free	Free	Stop	Stop	Stop	Stop	Stop	Stop
RT Channelized	-	-	None	-	-	None	-	-	None	-	-	None
Storage Length	0	-	-	-	-	-	-	-	0	-	-	-
Veh in Median Storage, #	-	0	-	-	0	-	-	0	-	-	0	-
Grade, %	-	0	-	-	0	-	-	0	-	-	0	-
Peak Hour Factor	100	100	100	100	100	100	100	100	100	100	100	100
Heavy Vehicles, %	3	3	3	3	3	3	3	3	3	3	3	3
Mvmt Flow	1	363	1	0	290	0	0	0	12	4	0	4

Major/Minor	Major1			Major2			Minor1			Minor2		
Conflicting Flow All	290	0	0	-	-	0	-	-	364	655	656	290
Stage 1	-	-	-	-	-	-	-	-	-	290	290	-
Stage 2	-	-	-	-	-	-	-	-	-	365	366	-
Critical Hdwy	4.13	-	-	-	-	-	-	-	6.23	7.13	6.53	6.23
Critical Hdwy Stg 1	-	-	-	-	-	-	-	-	-	6.13	5.53	-
Critical Hdwy Stg 2	-	-	-	-	-	-	-	-	-	6.13	5.53	-
Follow-up Hdwy	2.227	-	-	-	-	-	-	-	3.327	3.527	4.027	3.327
Pot Cap-1 Maneuver	1266	-	-	0	-	0	0	0	679	378	384	747
Stage 1	-	-	-	0	-	0	0	0	-	716	670	-
Stage 2	-	-	-	0	-	0	0	0	-	652	621	-
Platoon blocked, %	-	-	-	-	-	-	-	-	-	-	-	-
Mov Cap-1 Maneuver	1266	-	-	-	-	-	-	-	679	371	384	747
Mov Cap-2 Maneuver	-	-	-	-	-	-	-	-	-	477	469	-
Stage 1	-	-	-	-	-	-	-	-	-	716	670	-
Stage 2	-	-	-	-	-	-	-	-	-	640	620	-

Approach	EB	WB	NB	SB
HCM Control Delay, s/v	0.02	0	10.4	11.27
HCM LOS			B	B

Minor Lane/Major Mvmt	NBLn1	EBL	EBT	EBR	WBT	WBR	SBLn1
Capacity (veh/h)	679	1266	-	-	-	-	582
HCM Lane V/C Ratio	0.018	0.001	-	-	-	-	0.014
HCM Control Delay (s/veh)	10.4	7.8	-	-	-	-	11.3
HCM Lane LOS	B	A	-	-	-	-	B
HCM 95th %tile Q(veh)	0.1	0	-	-	-	-	0

Intersection						
Int Delay, s/veh	3.7					
Movement	EBL	EBT	WBT	WBR	SBL	SBR
Lane Configurations	↙	↑	↗		↘	
Traffic Vol, veh/h	80	169	511	197	80	60
Future Vol, veh/h	80	169	511	197	80	60
Conflicting Peds, #/hr	0	0	0	0	0	0
Sign Control	Free	Free	Free	Free	Stop	Stop
RT Channelized	-	None	-	None	-	None
Storage Length	0	-	-	-	0	-
Veh in Median Storage, #	-	0	0	-	0	-
Grade, %	-	0	0	-	0	-
Peak Hour Factor	100	100	100	100	100	100
Heavy Vehicles, %	3	3	3	3	3	3
Mvmt Flow	80	169	511	197	80	60

Major/Minor	Major1	Major2	Minor2		
Conflicting Flow All	708	0	-	0	939 610
Stage 1	-	-	-	-	610 -
Stage 2	-	-	-	-	329 -
Critical Hdwy	4.13	-	-	-	6.43 6.23
Critical Hdwy Stg 1	-	-	-	-	5.43 -
Critical Hdwy Stg 2	-	-	-	-	5.43 -
Follow-up Hdwy	2.227	-	-	-	3.527 3.327
Pot Cap-1 Maneuver	886	-	-	-	292 493
Stage 1	-	-	-	-	541 -
Stage 2	-	-	-	-	727 -
Platoon blocked, %		-	-	-	
Mov Cap-1 Maneuver	886	-	-	-	266 493
Mov Cap-2 Maneuver	-	-	-	-	266 -
Stage 1	-	-	-	-	492 -
Stage 2	-	-	-	-	727 -

Approach	EB	WB	SB
HCM Control Delay, s/v	3.04	0	23.61
HCM LOS			C

Minor Lane/Major Mvmt	EBL	EBT	WBT	WBR	SBLn1
Capacity (veh/h)	886	-	-	-	331
HCM Lane V/C Ratio	0.09	-	-	-	0.423
HCM Control Delay (s/veh)	9.5	-	-	-	23.6
HCM Lane LOS	A	-	-	-	C
HCM 95th %tile Q(veh)	0.3	-	-	-	2

Intersection						
Int Delay, s/veh	3.8					
Movement	EBL	EBT	WBT	WBR	SBL	SBR
Lane Configurations	↙	↑	↘		↘	↙
Traffic Vol, veh/h	80	174	528	197	80	60
Future Vol, veh/h	80	174	528	197	80	60
Conflicting Peds, #/hr	0	0	0	0	0	0
Sign Control	Free	Free	Free	Free	Stop	Stop
RT Channelized	-	None	-	None	-	None
Storage Length	0	-	-	-	0	-
Veh in Median Storage, #	-	0	0	-	0	-
Grade, %	-	0	0	-	0	-
Peak Hour Factor	100	100	100	100	100	100
Heavy Vehicles, %	3	3	3	3	3	3
Mvmt Flow	80	174	528	197	80	60

Major/Minor	Major1	Major2	Minor2		
Conflicting Flow All	725	0	-	0	961 627
Stage 1	-	-	-	-	627 -
Stage 2	-	-	-	-	334 -
Critical Hdwy	4.13	-	-	-	6.43 6.23
Critical Hdwy Stg 1	-	-	-	-	5.43 -
Critical Hdwy Stg 2	-	-	-	-	5.43 -
Follow-up Hdwy	2.227	-	-	-	3.527 3.327
Pot Cap-1 Maneuver	873	-	-	-	283 482
Stage 1	-	-	-	-	531 -
Stage 2	-	-	-	-	723 -
Platoon blocked, %		-	-	-	
Mov Cap-1 Maneuver	873	-	-	-	257 482
Mov Cap-2 Maneuver	-	-	-	-	257 -
Stage 1	-	-	-	-	482 -
Stage 2	-	-	-	-	723 -

Approach	EB	WB	SB
HCM Control Delay, s/v	3	0	24.55
HCM LOS			C

Minor Lane/Major Mvmt	EBL	EBT	WBT	WBR	SBLn1
Capacity (veh/h)	873	-	-	-	322
HCM Lane V/C Ratio	0.092	-	-	-	0.435
HCM Control Delay (s/veh)	9.5	-	-	-	24.5
HCM Lane LOS	A	-	-	-	C
HCM 95th %tile Q(veh)	0.3	-	-	-	2.1

Intersection						
Int Delay, s/veh	5.2					
Movement	EBL	EBT	WBT	WBR	SBL	SBR
Lane Configurations	↙	↑	↘		↘	↙
Traffic Vol, veh/h	28	326	233	40	137	117
Future Vol, veh/h	28	326	233	40	137	117
Conflicting Peds, #/hr	0	0	0	0	0	0
Sign Control	Free	Free	Free	Free	Stop	Stop
RT Channelized	-	None	-	None	-	None
Storage Length	0	-	-	-	0	-
Veh in Median Storage, #	-	0	0	-	0	-
Grade, %	-	0	0	-	0	-
Peak Hour Factor	100	100	100	100	100	100
Heavy Vehicles, %	3	3	3	3	3	3
Mvmt Flow	28	326	233	40	137	117

Major/Minor	Major1	Major2	Minor2		
Conflicting Flow All	273	0	-	0	635 253
Stage 1	-	-	-	-	253 -
Stage 2	-	-	-	-	382 -
Critical Hdwy	4.13	-	-	-	6.43 6.23
Critical Hdwy Stg 1	-	-	-	-	5.43 -
Critical Hdwy Stg 2	-	-	-	-	5.43 -
Follow-up Hdwy	2.227	-	-	-	3.527 3.327
Pot Cap-1 Maneuver	1284	-	-	-	441 783
Stage 1	-	-	-	-	787 -
Stage 2	-	-	-	-	688 -
Platoon blocked, %		-	-	-	
Mov Cap-1 Maneuver	1284	-	-	-	431 783
Mov Cap-2 Maneuver	-	-	-	-	431 -
Stage 1	-	-	-	-	770 -
Stage 2	-	-	-	-	688 -

Approach	EB	WB	SB
HCM Control Delay, s/v	0.62	0	17.28
HCM LOS			C

Minor Lane/Major Mvmt	EBL	EBT	WBT	WBR	SBLn1
Capacity (veh/h)	1284	-	-	-	544
HCM Lane V/C Ratio	0.022	-	-	-	0.467
HCM Control Delay (s/veh)	7.9	-	-	-	17.3
HCM Lane LOS	A	-	-	-	C
HCM 95th %tile Q(veh)	0.1	-	-	-	2.5

Intersection						
Int Delay, s/veh	5.3					
Movement	EBL	EBT	WBT	WBR	SBL	SBR
Lane Configurations	↙	↑	↗		↘	
Traffic Vol, veh/h	28	339	242	40	137	117
Future Vol, veh/h	28	339	242	40	137	117
Conflicting Peds, #/hr	0	0	0	0	0	0
Sign Control	Free	Free	Free	Free	Stop	Stop
RT Channelized	-	None	-	None	-	None
Storage Length	0	-	-	-	0	-
Veh in Median Storage, #	-	0	0	-	0	-
Grade, %	-	0	0	-	0	-
Peak Hour Factor	100	100	100	100	100	100
Heavy Vehicles, %	3	3	3	3	3	3
Mvmt Flow	28	339	242	40	137	117

Major/Minor	Major1	Major2	Minor2		
Conflicting Flow All	282	0	-	0	657 262
Stage 1	-	-	-	-	262 -
Stage 2	-	-	-	-	395 -
Critical Hdwy	4.13	-	-	-	6.43 6.23
Critical Hdwy Stg 1	-	-	-	-	5.43 -
Critical Hdwy Stg 2	-	-	-	-	5.43 -
Follow-up Hdwy	2.227	-	-	-	3.527 3.327
Pot Cap-1 Maneuver	1275	-	-	-	428 774
Stage 1	-	-	-	-	780 -
Stage 2	-	-	-	-	678 -
Platoon blocked, %		-	-	-	
Mov Cap-1 Maneuver	1275	-	-	-	419 774
Mov Cap-2 Maneuver	-	-	-	-	419 -
Stage 1	-	-	-	-	762 -
Stage 2	-	-	-	-	678 -

Approach	EB	WB	SB
HCM Control Delay, s/v	0.6	0	17.84
HCM LOS			C

Minor Lane/Major Mvmt	EBL	EBT	WBT	WBR	SBLn1
Capacity (veh/h)	1275	-	-	-	531
HCM Lane V/C Ratio	0.022	-	-	-	0.478
HCM Control Delay (s/veh)	7.9	-	-	-	17.8
HCM Lane LOS	A	-	-	-	C
HCM 95th %tile Q(veh)	0.1	-	-	-	2.6

Intersection												
Int Delay, s/veh	3.6											
Movement	EBL	EBT	EBR	WBL	WBT	WBR	NBL	NBT	NBR	SBL	SBT	SBR
Lane Configurations		↕			↕		↕	↕		↕	↕	
Traffic Vol, veh/h	12	0	8	8	0	8	28	68	12	44	40	16
Future Vol, veh/h	12	0	8	8	0	8	28	68	12	44	40	16
Conflicting Peds, #/hr	0	0	0	0	0	0	0	0	0	0	0	0
Sign Control	Stop	Stop	Stop	Stop	Stop	Stop	Free	Free	Free	Free	Free	Free
RT Channelized	-	-	None	-	-	None	-	-	None	-	-	None
Storage Length	-	-	-	-	-	-	50	-	-	50	-	-
Veh in Median Storage, #	-	0	-	-	0	-	-	0	-	-	0	-
Grade, %	-	0	-	-	0	-	-	0	-	-	0	-
Peak Hour Factor	100	100	100	100	100	100	100	100	100	100	100	100
Heavy Vehicles, %	3	3	3	3	3	3	3	3	3	3	3	3
Mvmt Flow	12	0	8	8	0	8	28	68	12	44	40	16

Major/Minor	Minor2		Minor1		Major1			Major2				
Conflicting Flow All	226	272	28	238	274	40	56	0	0	80	0	0
Stage 1	136	136	-	130	130	-	-	-	-	-	-	-
Stage 2	90	136	-	108	144	-	-	-	-	-	-	-
Critical Hdwy	7.56	6.56	6.96	7.56	6.56	6.96	4.16	-	-	4.16	-	-
Critical Hdwy Stg 1	6.56	5.56	-	6.56	5.56	-	-	-	-	-	-	-
Critical Hdwy Stg 2	6.56	5.56	-	6.56	5.56	-	-	-	-	-	-	-
Follow-up Hdwy	3.53	4.03	3.33	3.53	4.03	3.33	2.23	-	-	2.23	-	-
Pot Cap-1 Maneuver	707	631	1037	694	630	1019	1540	-	-	1509	-	-
Stage 1	850	781	-	857	785	-	-	-	-	-	-	-
Stage 2	904	781	-	883	774	-	-	-	-	-	-	-
Platoon blocked, %								-	-	-	-	-
Mov Cap-1 Maneuver	669	602	1037	656	600	1019	1540	-	-	1509	-	-
Mov Cap-2 Maneuver	669	602	-	656	600	-	-	-	-	-	-	-
Stage 1	825	758	-	842	771	-	-	-	-	-	-	-
Stage 2	881	766	-	850	752	-	-	-	-	-	-	-

Approach	EB	WB	NB	SB
HCM Control Delay, s/v	9.74	9.6	1.91	3.28
HCM LOS	A	A		

Minor Lane/Major Mvmt	NBL	NBT	NBR	EBLn1	WBLn1	SBL	SBT	SBR
Capacity (veh/h)	1540	-	-	780	798	1509	-	-
HCM Lane V/C Ratio	0.018	-	-	0.026	0.02	0.029	-	-
HCM Control Delay (s/veh)	7.4	-	-	9.7	9.6	7.5	-	-
HCM Lane LOS	A	-	-	A	A	A	-	-
HCM 95th %tile Q(veh)	0.1	-	-	0.1	0.1	0.1	-	-

Intersection												
Int Delay, s/veh	3.9											
Movement	EBL	EBT	EBR	WBL	WBT	WBR	NBL	NBT	NBR	SBL	SBT	SBR
Lane Configurations		↕			↕		↕	↕		↕	↕	
Traffic Vol, veh/h	12	0	8	11	0	8	28	76	12	61	40	16
Future Vol, veh/h	12	0	8	11	0	8	28	76	12	61	40	16
Conflicting Peds, #/hr	0	0	0	0	0	0	0	0	0	0	0	0
Sign Control	Stop	Stop	Stop	Stop	Stop	Stop	Free	Free	Free	Free	Free	Free
RT Channelized	-	-	None	-	-	None	-	-	None	-	-	None
Storage Length	-	-	-	-	-	-	50	-	-	50	-	-
Veh in Median Storage, #	-	0	-	-	0	-	-	0	-	-	0	-
Grade, %	-	0	-	-	0	-	-	0	-	-	0	-
Peak Hour Factor	100	100	100	100	100	100	100	100	100	100	100	100
Heavy Vehicles, %	3	3	3	3	3	3	3	3	3	3	3	3
Mvmt Flow	12	0	8	11	0	8	28	76	12	61	40	16

Major/Minor	Minor2		Minor1		Major1		Major2					
Conflicting Flow All	264	314	28	280	316	44	56	0	0	88	0	0
Stage 1	170	170	-	138	138	-	-	-	-	-	-	-
Stage 2	94	144	-	142	178	-	-	-	-	-	-	-
Critical Hdwy	7.56	6.56	6.96	7.56	6.56	6.96	4.16	-	-	4.16	-	-
Critical Hdwy Stg 1	6.56	5.56	-	6.56	5.56	-	-	-	-	-	-	-
Critical Hdwy Stg 2	6.56	5.56	-	6.56	5.56	-	-	-	-	-	-	-
Follow-up Hdwy	3.53	4.03	3.33	3.53	4.03	3.33	2.23	-	-	2.23	-	-
Pot Cap-1 Maneuver	665	598	1037	648	596	1013	1540	-	-	1498	-	-
Stage 1	812	754	-	848	779	-	-	-	-	-	-	-
Stage 2	899	774	-	843	748	-	-	-	-	-	-	-
Platoon blocked, %								-	-	-	-	-
Mov Cap-1 Maneuver	621	563	1037	605	562	1013	1540	-	-	1498	-	-
Mov Cap-2 Maneuver	621	563	-	605	562	-	-	-	-	-	-	-
Stage 1	779	724	-	833	765	-	-	-	-	-	-	-
Stage 2	876	760	-	803	718	-	-	-	-	-	-	-

Approach	EB	WB	NB	SB
HCM Control Delay, s/v	10	10.07	1.78	3.91
HCM LOS	A	B		

Minor Lane/Major Mvmt	NBL	NBT	NBR	EBLn1	WBLn1	SBL	SBT	SBR
Capacity (veh/h)	1540	-	-	740	729	1498	-	-
HCM Lane V/C Ratio	0.018	-	-	0.027	0.026	0.041	-	-
HCM Control Delay (s/veh)	7.4	-	-	10	10.1	7.5	-	-
HCM Lane LOS	A	-	-	A	B	A	-	-
HCM 95th %tile Q(veh)	0.1	-	-	0.1	0.1	0.1	-	-

Intersection												
Int Delay, s/veh	5											
Movement	EBL	EBT	EBR	WBL	WBT	WBR	NBL	NBT	NBR	SBL	SBT	SBR
Lane Configurations		↕			↕		↕	↕		↕	↕	
Traffic Vol, veh/h	48	0	8	20	0	56	0	84	4	4	20	4
Future Vol, veh/h	48	0	8	20	0	56	0	84	4	4	20	4
Conflicting Peds, #/hr	0	0	0	0	0	0	0	0	0	0	0	0
Sign Control	Stop	Stop	Stop	Stop	Stop	Stop	Free	Free	Free	Free	Free	Free
RT Channelized	-	-	None	-	-	None	-	-	None	-	-	None
Storage Length	-	-	-	-	-	-	50	-	-	50	-	-
Veh in Median Storage, #	-	0	-	-	0	-	-	0	-	-	0	-
Grade, %	-	0	-	-	0	-	-	0	-	-	0	-
Peak Hour Factor	100	100	100	100	100	100	100	100	100	100	100	100
Heavy Vehicles, %	3	3	3	3	3	3	3	3	3	3	3	3
Mvmt Flow	48	0	8	20	0	56	0	84	4	4	20	4

Major/Minor	Minor2		Minor1		Major1			Major2				
Conflicting Flow All	72	118	12	104	118	44	24	0	0	88	0	0
Stage 1	30	30	-	86	86	-	-	-	-	-	-	-
Stage 2	42	88	-	18	32	-	-	-	-	-	-	-
Critical Hdwy	7.56	6.56	6.96	7.56	6.56	6.96	4.16	-	-	4.16	-	-
Critical Hdwy Stg 1	6.56	5.56	-	6.56	5.56	-	-	-	-	-	-	-
Critical Hdwy Stg 2	6.56	5.56	-	6.56	5.56	-	-	-	-	-	-	-
Follow-up Hdwy	3.53	4.03	3.33	3.53	4.03	3.33	2.23	-	-	2.23	-	-
Pot Cap-1 Maneuver	908	769	1062	862	769	1013	1582	-	-	1498	-	-
Stage 1	980	867	-	909	820	-	-	-	-	-	-	-
Stage 2	964	819	-	996	866	-	-	-	-	-	-	-
Platoon blocked, %								-	-	-	-	-
Mov Cap-1 Maneuver	856	767	1062	853	767	1013	1582	-	-	1498	-	-
Mov Cap-2 Maneuver	856	767	-	853	767	-	-	-	-	-	-	-
Stage 1	977	865	-	909	820	-	-	-	-	-	-	-
Stage 2	911	819	-	986	863	-	-	-	-	-	-	-

Approach	EB		WB		NB		SB	
HCM Control Delay, s/v	9.37		9.05		0		1.06	
HCM LOS	A		A					

Minor Lane/Major Mvmt	NBL	NBT	NBR	EBLn1	WBLn1	SBL	SBT	SBR
Capacity (veh/h)	1582	-	-	880	966	1498	-	-
HCM Lane V/C Ratio	-	-	-	0.064	0.079	0.003	-	-
HCM Control Delay (s/veh)	0	-	-	9.4	9	7.4	-	-
HCM Lane LOS	A	-	-	A	A	A	-	-
HCM 95th %tile Q(veh)	0	-	-	0.2	0.3	0	-	-

Intersection												
Int Delay, s/veh	5.4											
Movement	EBL	EBT	EBR	WBL	WBT	WBR	NBL	NBT	NBR	SBL	SBT	SBR
Lane Configurations		↕			↕		↕	↕		↕	↕	
Traffic Vol, veh/h	48	0	8	27	0	71	0	88	4	13	20	4
Future Vol, veh/h	48	0	8	27	0	71	0	88	4	13	20	4
Conflicting Peds, #/hr	0	0	0	0	0	0	0	0	0	0	0	0
Sign Control	Stop	Stop	Stop	Stop	Stop	Stop	Free	Free	Free	Free	Free	Free
RT Channelized	-	-	None	-	-	None	-	-	None	-	-	None
Storage Length	-	-	-	-	-	-	50	-	-	50	-	-
Veh in Median Storage, #	-	0	-	-	0	-	-	0	-	-	0	-
Grade, %	-	0	-	-	0	-	-	0	-	-	0	-
Peak Hour Factor	100	100	100	100	100	100	100	100	100	100	100	100
Heavy Vehicles, %	3	3	3	3	3	3	3	3	3	3	3	3
Mvmt Flow	48	0	8	27	0	71	0	88	4	13	20	4

Major/Minor	Minor2		Minor1		Major1			Major2				
Conflicting Flow All	92	140	12	126	140	46	24	0	0	92	0	0
Stage 1	48	48	-	90	90	-	-	-	-	-	-	-
Stage 2	44	92	-	36	50	-	-	-	-	-	-	-
Critical Hdwy	7.56	6.56	6.96	7.56	6.56	6.96	4.16	-	-	4.16	-	-
Critical Hdwy Stg 1	6.56	5.56	-	6.56	5.56	-	-	-	-	-	-	-
Critical Hdwy Stg 2	6.56	5.56	-	6.56	5.56	-	-	-	-	-	-	-
Follow-up Hdwy	3.53	4.03	3.33	3.53	4.03	3.33	2.23	-	-	2.23	-	-
Pot Cap-1 Maneuver	879	748	1062	832	748	1010	1582	-	-	1493	-	-
Stage 1	957	852	-	904	817	-	-	-	-	-	-	-
Stage 2	962	816	-	972	850	-	-	-	-	-	-	-
Platoon blocked, %								-	-	-	-	-
Mov Cap-1 Maneuver	810	741	1062	819	741	1010	1582	-	-	1493	-	-
Mov Cap-2 Maneuver	810	741	-	819	741	-	-	-	-	-	-	-
Stage 1	948	845	-	904	817	-	-	-	-	-	-	-
Stage 2	894	816	-	956	843	-	-	-	-	-	-	-

Approach	EB		WB		NB		SB	
HCM Control Delay, s/v	9.6		9.23		0		2.61	
HCM LOS	A		A					

Minor Lane/Major Mvmt	NBL	NBT	NBR	EBLn1	WBLn1	SBL	SBT	SBR
Capacity (veh/h)	1582	-	-	839	949	1493	-	-
HCM Lane V/C Ratio	-	-	-	0.067	0.103	0.009	-	-
HCM Control Delay (s/veh)	0	-	-	9.6	9.2	7.4	-	-
HCM Lane LOS	A	-	-	A	A	A	-	-
HCM 95th %tile Q(veh)	0	-	-	0.2	0.3	0	-	-

Intersection						
Int Delay, s/veh	0					
Movement	WBL	WBR	NBT	NBR	SBL	SBT
Lane Configurations		↗	↕			↕
Traffic Vol, veh/h	0	0	96	0	0	149
Future Vol, veh/h	0	0	96	0	0	149
Conflicting Peds, #/hr	0	0	0	0	0	0
Sign Control	Stop	Stop	Free	Free	Free	Free
RT Channelized	-	None	-	None	-	None
Storage Length	-	0	-	-	-	-
Veh in Median Storage, #	0	-	0	-	-	0
Grade, %	0	-	0	-	-	0
Peak Hour Factor	100	100	100	100	100	100
Heavy Vehicles, %	3	3	3	3	3	3
Mvmt Flow	0	0	96	0	0	149

Major/Minor	Minor1	Major1	Major2			
Conflicting Flow All	-	48	0	0	-	-
Stage 1	-	-	-	-	-	-
Stage 2	-	-	-	-	-	-
Critical Hdwy	-	6.96	-	-	-	-
Critical Hdwy Stg 1	-	-	-	-	-	-
Critical Hdwy Stg 2	-	-	-	-	-	-
Follow-up Hdwy	-	3.33	-	-	-	-
Pot Cap-1 Maneuver	0	1007	-	-	0	-
Stage 1	0	-	-	-	0	-
Stage 2	0	-	-	-	0	-
Platoon blocked, %			-	-	-	-
Mov Cap-1 Maneuver	-	1007	-	-	-	-
Mov Cap-2 Maneuver	-	-	-	-	-	-
Stage 1	-	-	-	-	-	-
Stage 2	-	-	-	-	-	-

Approach	WB	NB	SB
HCM Control Delay, s/v	0	0	0
HCM LOS	A		

Minor Lane/Major Mvmt	NBT	NBRWBLn1	SBT
Capacity (veh/h)	-	-	-
HCM Lane V/C Ratio	-	-	-
HCM Control Delay (s/veh)	-	-	0
HCM Lane LOS	-	-	A
HCM 95th %tile Q(veh)	-	-	-

Intersection						
Int Delay, s/veh	0					
Movement	WBL	WBR	NBT	NBR	SBL	SBT
Lane Configurations		↗	↕			↕
Traffic Vol, veh/h	0	1	96	8	0	149
Future Vol, veh/h	0	1	96	8	0	149
Conflicting Peds, #/hr	0	0	0	0	0	0
Sign Control	Stop	Stop	Free	Free	Free	Free
RT Channelized	-	None	-	None	-	None
Storage Length	-	0	-	-	-	-
Veh in Median Storage, #	0	-	0	-	-	0
Grade, %	0	-	0	-	-	0
Peak Hour Factor	100	100	100	100	100	100
Heavy Vehicles, %	3	3	3	3	3	3
Mvmt Flow	0	1	96	8	0	149

Major/Minor	Minor1	Major1	Major2
Conflicting Flow All	-	52	0
Stage 1	-	-	-
Stage 2	-	-	-
Critical Hdwy	-	6.96	-
Critical Hdwy Stg 1	-	-	-
Critical Hdwy Stg 2	-	-	-
Follow-up Hdwy	-	3.33	-
Pot Cap-1 Maneuver	0	1001	-
Stage 1	0	-	-
Stage 2	0	-	-
Platoon blocked, %	-	-	-
Mov Cap-1 Maneuver	-	1001	-
Mov Cap-2 Maneuver	-	-	-
Stage 1	-	-	-
Stage 2	-	-	-

Approach	WB	NB	SB
HCM Control Delay, s/v	8.6	0	0
HCM LOS	A		

Minor Lane/Major Mvmt	NBT	NBRWBLn1	SBT
Capacity (veh/h)	-	-	1001
HCM Lane V/C Ratio	-	-	0.001
HCM Control Delay (s/veh)	-	-	8.6
HCM Lane LOS	-	-	A
HCM 95th %tile Q(veh)	-	-	0

Intersection						
Int Delay, s/veh	0					
Movement	WBL	WBR	NBT	NBR	SBL	SBT
Lane Configurations		↗	↕			↕
Traffic Vol, veh/h	0	0	164	0	0	28
Future Vol, veh/h	0	0	164	0	0	28
Conflicting Peds, #/hr	0	0	0	0	0	0
Sign Control	Stop	Stop	Free	Free	Free	Free
RT Channelized	-	None	-	None	-	None
Storage Length	-	0	-	-	-	-
Veh in Median Storage, #	0	-	0	-	-	0
Grade, %	0	-	0	-	-	0
Peak Hour Factor	100	100	100	100	100	100
Heavy Vehicles, %	3	3	3	3	3	3
Mvmt Flow	0	0	164	0	0	28

Major/Minor	Minor1	Major1	Major2
Conflicting Flow All	-	82	0
Stage 1	-	-	-
Stage 2	-	-	-
Critical Hdwy	-	6.96	-
Critical Hdwy Stg 1	-	-	-
Critical Hdwy Stg 2	-	-	-
Follow-up Hdwy	-	3.33	-
Pot Cap-1 Maneuver	0	958	-
Stage 1	0	-	-
Stage 2	0	-	-
Platoon blocked, %	-	-	-
Mov Cap-1 Maneuver	-	958	-
Mov Cap-2 Maneuver	-	-	-
Stage 1	-	-	-
Stage 2	-	-	-

Approach	WB	NB	SB
HCM Control Delay, s/v	0	0	0
HCM LOS	A		

Minor Lane/Major Mvmt	NBT	NBRWBLn1	SBT
Capacity (veh/h)	-	-	-
HCM Lane V/C Ratio	-	-	-
HCM Control Delay (s/veh)	-	-	0
HCM Lane LOS	-	-	A
HCM 95th %tile Q(veh)	-	-	-

Intersection						
Int Delay, s/veh	0.1					
Movement	WBL	WBR	NBT	NBR	SBL	SBT
Lane Configurations		↗	↕			↕
Traffic Vol, veh/h	0	3	164	4	0	28
Future Vol, veh/h	0	3	164	4	0	28
Conflicting Peds, #/hr	0	0	0	0	0	0
Sign Control	Stop	Stop	Free	Free	Free	Free
RT Channelized	-	None	-	None	-	None
Storage Length	-	0	-	-	-	-
Veh in Median Storage, #	0	-	0	-	-	0
Grade, %	0	-	0	-	-	0
Peak Hour Factor	100	100	100	100	100	100
Heavy Vehicles, %	3	3	3	3	3	3
Mvmt Flow	0	3	164	4	0	28

Major/Minor	Minor1	Major1	Major2			
Conflicting Flow All	-	84	0	0	-	-
Stage 1	-	-	-	-	-	-
Stage 2	-	-	-	-	-	-
Critical Hdwy	-	6.96	-	-	-	-
Critical Hdwy Stg 1	-	-	-	-	-	-
Critical Hdwy Stg 2	-	-	-	-	-	-
Follow-up Hdwy	-	3.33	-	-	-	-
Pot Cap-1 Maneuver	0	955	-	-	0	-
Stage 1	0	-	-	-	0	-
Stage 2	0	-	-	-	0	-
Platoon blocked, %			-	-	-	-
Mov Cap-1 Maneuver	-	955	-	-	-	-
Mov Cap-2 Maneuver	-	-	-	-	-	-
Stage 1	-	-	-	-	-	-
Stage 2	-	-	-	-	-	-

Approach	WB	NB	SB
HCM Control Delay, s/v	8.78	0	0
HCM LOS	A		

Minor Lane/Major Mvmt	NBT	NBRWBLn1	SBT
Capacity (veh/h)	-	-	955
HCM Lane V/C Ratio	-	-	0.003
HCM Control Delay (s/veh)	-	-	8.8
HCM Lane LOS	-	-	A
HCM 95th %tile Q(veh)	-	-	0

**Pages A-183 through A-354
(INTENTIONALLY LEFT BLANK)**

Intersection No.:

System:
 Address:

Intersection Name:

Revision Date

Timing Data

Phase I.D.:	1	2	3	4	5	6	7	8
Phase Dir.:		SB		E/W		SB		
Min Grn		16		8		16		
Walk:		7		7		0		
Ped Clr:		16		14		0		
Veh Ext:		3.0		2.0		3.0		
Veh Ext2:		3.0		2.0		3.0		
Max 1:		36		24		36		
Max 2:		36		24		36		
Max 3:								
Yellow:		5.0		3.5		5.0		
Red Clr		2.0		2.0		2.0		

SIGN

Recall Data

Locking Memory:								
Vehicle Recall:		X				X		
Ped Recall:								
Recall To Max:								

Flash Mode:

Start Up Mode:

Time:

First Phases:

Start In:

Overlap Phases:

Overlap	Par Ph	Grn	Yel	Red	
A	2(SB)	3.5	4.0	1.0	(Lagging Overlap)
B					
C					
D					

NOTES:

1. Intersection added as a result of Big "I" reconstruction, 5/17/02.
2. Changed clearance interval 7/31/06.
3. Flashing Advance Warning Sign installed 500 ft. north of intersection, 5/14/08.
4. Clearance intervals updated to NMDOT standard by BB, 1/2/14.
5. Clearance changes for yellow and red based on recommendation from NMDOT, 12/26/17

Intersection No.: 1157

System: Centrac
Address: 1

Intersection Name: LOMAS & LOCUST

Revision Date: 8/24/2022

Timing Data

Phase I.D.:	1	2	3	4	5	6	7	8
Phase Dir.:	W-S	EB		SB		WB		
Min Grn	3	16		8		16		
Walk:	0	7		7		7		
Ped Clr:	0	10		36		19		
Veh Ext:	2.0	4.0		3.0		4.0		
Veh Ext2:								
Max 1:	16	36		20		36		
Max 2:								
Max 3:								
Yellow:	4.0	4.0		4.0		4.0		
Red Clr	1.0	1.0		2.0		1.0		
Delay Grn				8.0				

Recall Data

Locking Memory:								
Vehicle Recall:								
Ped Recall:								
Recall To Max:		X				X		

Flash Mode: ALL RED

Start Up Mode: ALL RED
 Time: 8 SEC.
 First Phases: 2 & 6
 Start In: GREEN

Overlap Phases: NONE

Overlap	Par Ph	Grn	Yel	Red
A				
B				
C				
D				

- NOTES:
1. Controller changeout from 911 to 820. Date 8/9/94.
 2. Red clearance time change in data base, 7/5/95.
 3. Update timing sheet: Prom Rev. from A/B to W., 8/5/98.
 4. Updated file, 8/8/00.
 5. Phasing changed due to "Big I" reconstruction, 5/16/02.
 6. Timing sheet updated, 5/5/03.
 7. Timing sheet updated, 2/12/04.
 8. Clearance intervals updated to NMDOT standard by BB, 12/30/13.
 9. Programmed a Ped Jump to the South bound. 8/24/2022 MA

1157 - Lomas & Locust

COORDINATOR OPTIONS (MM 3-1)

MANUAL PATTERN	AUTO	ECPI COORD	YES
SYSTEM SOURCE	SYS	SYSTEM FORMAT	PTN
SPLITS IN	PERCENT	OFFSET IN	PERCENT
TRANSITION	SMOOTH	MAX SELECT	MAXINH
DWELL/ADD TIME	0	ENABLE MAN SYNC	NO
DLY COORD WK-LZ	NO	FORCE OFF	FLOAT
OFFSET REF	LEAD	CAL USE PED TM	NO
PED RECALL	NO	PED RESERVE	NO
LOCAL ZERO OVRD	NO	FO ADD INI GRN	NO
RE-SYNC COUNT	0	MULTISYNC	NO

COORDINATION PATTERN 1 (MM 3-2) AM

USE SPLIT PATTERN	1	SPLIT SUM	100%
TS2 (PAT-OFF)	0-1		
CYCLE	110.00	STD (COS)	111
OFFSET VAL	53%	58.3	
ACTUATED COORD	YES	TIMING PLAN	0
ACT WALK REST	NO	SEQUENCE	2
PHASE RESRVCE	NO	ACTION PLAN	0

PHASE	1	2	3	4	5	6	7	8
DIRECTION	W-S	EB		SB		WB		
SPLITS	15	30		55		45		
	16.5	33		60.5		49.5		

PHASE	1	2	3	4	5	6	7	8
COORD PHASE		X				X		
VEH RECALL								
MAX RECALL		X				X		

COORDINATION PATTERN 3

USE SPLIT PATTERN	3	SPLIT SUM	100%
TS2 (PAT-OFF)	0-3		
CYCLE	110s	STD (COS)	131
OFFSET VAL	53%		
ACTUATED COORD	YES	TIMING PLAN	0
ACT WALK REST	NO	SEQUENCE	2
PHASE RESRVCE	NO	ACTION PLAN	0

PHASE	1	2	3	4	5	6	7	8
DIRECTION	W-S	EB		SB		WB		
SPLITS	15	30		55		45		

PHASE	1	2	3	4	5	6	7	8
COORD PHASE		X				X		
VEH RECALL								
MAX RECALL		X				X		

ASC3 COORDINATION PLAN DATA

7/28/2024 4:40 PM

COORDINATION PATTERN 5

USE SPLIT PATTERN	5	SPLIT SUM	100%
TS2 (PAT-OFF)	0-5		
CYCLE	120.00	STD (COS)	151
OFFSET VAL	53%	63.6	
ACTUATED COORD	YES	TIMING PLAN	0
ACT WALK REST	NO	SEQUENCE	2
PHASE RESRVCE	NO	ACTION PLAN	0

PHASE	1	2	3	4	5	6	7	8
DIRECTION	W-S	EB		SB		WB		
SPLITS	25	41		34		66		
	30	49.2		40.8		79.2		

PHASE	1	2	3	4	5	6	7	8
COORD PHASE		X				X		
VEH RECALL								
MAX RECALL		X				X		

PM

CLOCK / CALENDAR DATA (MM 5-1)

CURRENT DATE	CURRENT DOW	CURRENT TOD
ENA ACTION PLAN	0	
SYNC REF TIME	00:00	SYNC REF REF TIME
TIME FROM GMT	+00	DAY LIGHT SAVE NO
TIME RESET INPUT SET TIME		3:30:00

ACTION PLAN 1 (MM 5-2)

PATTERN	1	SYS OVERRIDE	NO
TIMING PLAN	0	SEQUENCE	0
VEHICLE DETECTOR PLAN	0.00	DET LOG	NONE
FLASH	--	RED REST	NO
VEH DET DIAG PLN	0	PED DET DIAG PLN	0
DIMMING ENABLE	NO		

ACTION PLAN 3

PATTERN	3	SYS OVERRIDE	NO
TIMING PLAN	0	SEQUENCE	0
VEHICLE DETECTOR PLAN	0.00	DET LOG	NONE
FLASH	--	RED REST	NO
VEH DET DIAG PLN	0	PED DET DIAG PLN	0
DIMMING ENABLE	NO		

ACTION PLAN 5

PATTERN	5	SYS OVERRIDE	NO
TIMING PLAN	0	SEQUENCE	0
VEHICLE DETECTOR PLAN	0.00	DET LOG	NONE
FLASH	--	RED REST	NO
VEH DET DIAG PLN	0	PED DET DIAG PLN	0
DIMMING ENABLE	NO		

ASC3 COORDINATION PLAN DATA

7/28/2024 4:40 PM

ACTION PLAN 100			
PATTERN	254	SYS OVERRIDE	NO
TIMING PLAN	0	SEQUENCE	0
VEHICLE DETECTOR PLAN	0.00	DET LOG	NONE
FLASH	--	RED REST	NO
VEH DET DIAG PLN	0	PED DET DIAG PLN	0
DIMMING ENABLE	NO		

DAY PLAN/EVENT 1 (MM 5-3)		
EVENT	ACTION PLAN	START TIME
1	3	7:00
2	100	22:00
3	0	00:00

DAY PLAN/EVENT 2		
EVENT	ACTION PLAN	START TIME
1	1	6:30
2	3	9:00
3	5	15:00
4	3	18:30
5	100	22:00
6	0	00:00
7	0	00:00

AM

PM

DAY PLAN/EVENT 3		
EVENT	ACTION PLAN	START TIME
1	3	7:00
2	100	22:00
3	0	00:00

SCHEDULE NUMBER 1 (MM 5-4)												
SCHEDULE NUMBER	1											
DAY PLAN NO	1 CLEAR ALL FIELDS											
SELECT ALL MONTHS				DOW				DOM				
MONTH	J	F	M	A	M	J	J	A	S	O	N	D
	X	X	X	X	X	X	X	X	X	X	X	X
DAY(DOW)	SUN	MON	TUE	WED	THU	FRI	SAT					
	X					
DAY(DOM)	1	2	3	4	5	6	7	8	9	10	11	
	X	X	X	X	X	X	X	X	X	X	X	
	12	13	14	15	16	17	18	19	20	21	22	
	X	X	X	X	X	X	X	X	X	X	X	
	23	24	25	26	27	28	29	30	31			
	X	X	X	X	X	X	X	X	X			

ASC3 COORDINATION PLAN DATA

7/28/2024 4:40 PM

SCHEDULE NUMBER 2												
SCHEDULE NUMBER	2											
DAY PLAN NO	2		CLEAR ALL FIELDS									
SELECT ALL MONTHS				DOW				DOM				
MONTH	J	F	M	A	M	J	J	A	S	O	N	D
	X	X	X	X	X	X	X	X	X	X	X	X
DAY(DOW)	SUN	MON	TUE	WED	THU	FRI	SAT					
	.	X	X	X	X	X	.					
DAY(DOM)	1	2	3	4	5	6	7	8	9	10	11	
	X	X	X	X	X	X	X	X	X	X	X	
	12	13	14	15	16	17	18	19	20	21	22	
	X	X	X	X	X	X	X	X	X	X	X	
	23	24	25	26	27	28	29	30	31			
	X	X	X	X	X	X	X	X	X			

SCHEDULE NUMBER 3												
SCHEDULE NUMBER	3											
DAY PLAN NO	3		CLEAR ALL FIELDS									
SELECT ALL MONTHS				DOW				DOM				
MONTH	J	F	M	A	M	J	J	A	S	O	N	D
	X	X	X	X	X	X	X	X	X	X	X	X
DAY(DOW)	SUN	MON	TUE	WED	THU	FRI	SAT					
	X					
DAY(DOM)	1	2	3	4	5	6	7	8	9	10	11	
	X	X	X	X	X	X	X	X	X	X	X	
	12	13	14	15	16	17	18	19	20	21	22	
	X	X	X	X	X	X	X	X	X	X	X	
	23	24	25	26	27	28	29	30	31			
	X	X	X	X	X	X	X	X	X			

NOTES: 1. Coord sheet updated by BB, 5/14/13.

Traffic Count Data Sheet

Year Counts Taken: **2024**

E-W Street **Mountain Rd.**
N-S Street: **I-25 W. Frntg**

Unsignalized

Speed Limit (Mountain Rd.)= **30**
Speed Limit (I-25 W. Frntg)= **40**
4/18/24

Begin Time	End Time	Eastbound (Mountain Rd.)			Westbound (Mountain Rd.)			Northbound (I-25 W. Frntg)			Southbound (I-25 W. Frntg)		
		L	T	R	L	T	R	L	T	R	L	T	R
7:00 AM	7:15 AM	0	29	11	0	18	0	0	0	0	72	229	39
7:15 AM	7:30 AM	0	20	24	1	21	0	0	0	0	81	267	67
7:30 AM	7:45 AM	0	21	20	0	25	0	0	0	0	78	313	67
7:45 AM	8:00 AM	0	25	19	0	33	0	0	0	0	67	408	79
8:00 AM	8:15 AM	0	33	19	0	71	0	0	0	0	54	343	84
8:15 AM	8:30 AM	0	47	42	0	43	0	0	0	0	49	312	108
8:30 AM	8:45 AM	0	18	13	0	23	0	0	0	0	43	313	56
8:45 AM	9:00 AM	0	23	0	0	18	13	0	0	0	38	309	34
4X Peak 15-Min. Vol. (AM)		0	100	76	0	132	0	0	0	0	268	1632	316
% of Total Traffic		0.0%	4.0%	3.0%	0.0%	5.2%	0.0%	0.0%	0.0%	0.0%	10.6%	64.7%	12.5%
% Directional			7.0%			5.2%	Intersection					87.8%	

Begin Time	End Time	Eastbound (Mountain Rd.)			Westbound (Mountain Rd.)			Northbound (I-25 W. Frntg)			Southbound (I-25 W. Frntg)		
		L	T	R	L	T	R	L	T	R	L	T	R
4:00 PM	4:15 PM	0	28	28	0	21	0	0	0	0	3	167	39
4:15 PM	4:30 PM	0	35	16	1	14	0	0	0	0	4	160	28
4:30 PM	4:45 PM	0	37	15	1	14	0	0	0	0	8	194	23
4:45 PM	5:00 PM	0	41	17	0	19	0	0	0	0	4	176	33
5:00 PM	5:15 PM	0	78	37	1	18	0	0	0	0	6	182	40
5:15 PM	5:30 PM	0	46	17	0	16	0	0	0	0	5	164	39
5:30 PM	5:45 PM	0	20	5	3	9	0	0	0	0	5	168	46
5:45 PM	6:00 PM	0	16	7	1	13	0	0	0	0	7	137	27
4X Peak 15-Min. Vol. (PM)		0	312	148	4	72	0	0	0	0	24	728	160
% of Total Traffic		0.0%	21.5%	10.2%	0.3%	5.0%	0.0%	0.0%	0.0%	0.0%	1.7%	50.3%	11.0%
% Directional			31.8%			5.2%	Intersection					63.0%	

Traffic Count Data Sheet

Year Counts Taken: **2024**

E-W Street **Lomas Blvd.**
 N-S Street: **I-25 W. Frntg**

Speed Limit (Lomas Blvd.)= **35**
 Speed Limit (I-25 W. Frntg)= **35**
4/18/24

Unsignalized

Begin Time	End Time	Eastbound (Lomas Blvd.)			Westbound (Lomas Blvd.)			Northbound (I-25 W. Frntg)			Southbound (I-25 W. Frntg)		
		L	T	R	L	T	R	L	T	R	L	T	R
7:00 AM	7:15 AM	0	124	11	21	93	0	0	0	0	124	26	56
7:15 AM	7:30 AM	0	166	22	29	140	0	0	0	0	133	39	70
7:30 AM	7:45 AM	0	194	21	33	186	0	0	0	0	190	67	99
7:45 AM	8:00 AM	0	208	35	22	239	0	0	0	0	188	65	117
8:00 AM	8:15 AM	0	208	24	21	164	0	0	0	0	172	65	119
8:15 AM	8:30 AM	0	222	35	17	191	0	0	0	0	115	58	94
8:30 AM	8:45 AM	0	205	27	17	156	0	0	0	0	154	72	68
8:45 AM	9:00 AM	0	181	18	28	159	0	0	0	0	136	53	76
4X Peak 15-Min. Vol. (AM)		0	832	140	88	956	0	0	0	0	752	260	468
% of Total Traffic		0.0%	23.8%	4.0%	2.5%	27.3%	0.0%	0.0%	0.0%	0.0%	21.5%	7.4%	13.4%
% Directional			27.8%			29.9%	Intersection			0.0%		42.3%	

Begin Time	End Time	Eastbound (Lomas Blvd.)			Westbound (Lomas Blvd.)			Northbound (I-25 W. Frntg)			Southbound (I-25 W. Frntg)		
		L	T	R	L	T	R	L	T	R	L	T	R
4:00 PM	4:15 PM	0	235	46	60	177	0	0	0	0	81	70	40
4:15 PM	4:30 PM	0	244	39	58	190	0	0	0	0	67	57	39
4:30 PM	4:45 PM	0	242	38	62	229	0	0	0	0	66	93	60
4:45 PM	5:00 PM	0	212	37	55	252	0	0	0	0	71	46	66
5:00 PM	5:15 PM	0	235	54	52	248	0	0	0	0	79	82	47
5:15 PM	5:30 PM	0	233	44	60	254	0	0	0	0	62	63	66
5:30 PM	5:45 PM	0	166	28	44	161	0	0	0	0	72	54	56
5:45 PM	6:00 PM	0	134	21	45	225	0	0	0	0	62	55	54
4X Peak 15-Min. Vol. (PM)		0	940	216	208	992	0	0	0	0	316	328	188
% of Total Traffic		0.0%	29.5%	6.8%	6.5%	31.1%	0.0%	0.0%	0.0%	0.0%	9.9%	10.3%	5.9%
% Directional			36.3%			37.6%	Intersection			0.0%		26.1%	

Traffic Count Data Sheet

Year Counts Taken: **2024**

E-W Street **Lomas Blvd.**
N-S Street: **Woodward Pl.**

Speed Limit (Lomas Blvd.)= **35**
Speed Limit (Woodward Pl.)= **30**
4/18/24

Unsignalized

Begin Time	End Time	Eastbound (Lomas Blvd.)			Westbound (Lomas Blvd.)			Northbound (Woodward Pl.)			Southbound (Woodward Pl.)		
		L	T	R	L	T	R	L	T	R	L	T	R
7:00 AM	7:15 AM	6	126	0	5	140	16	0	0	2	4	0	5
7:15 AM	7:30 AM	8	174	5	2	201	20	0	0	0	8	0	3
7:30 AM	7:45 AM	18	207	1	5	233	24	0	0	0	8	0	6
7:45 AM	8:00 AM	14	227	3	9	294	32	0	0	0	13	0	8
8:00 AM	8:15 AM	11	232	2	3	259	23	0	0	1	4	1	7
8:15 AM	8:30 AM	22	237	2	6	245	30	0	0	1	6	0	11
8:30 AM	8:45 AM	14	222	3	9	211	14	0	0	2	4	0	6
8:45 AM	9:00 AM	7	189	6	3	211	17	0	0	2	7	0	4
4X Peak 15-Min. Vol. (AM)		56	908	12	36	1176	128	0	0	0	52	0	32
% of Total Traffic		2.3%	37.8%	0.5%	1.5%	49.0%	5.3%	0.0%	0.0%	0.0%	2.2%	0.0%	1.3%
% Directional			40.7%			55.8%	Intersection		0.0%			3.5%	

Begin Time	End Time	Eastbound (Lomas Blvd.)			Westbound (Lomas Blvd.)			Northbound (Woodward Pl.)			Southbound (Woodward Pl.)		
		L	T	R	L	T	R	L	T	R	L	T	R
4:00 PM	4:15 PM	2	281	3	1	220	8	1	0	3	11	0	12
4:15 PM	4:30 PM	9	255	1	1	231	6	1	0	5	12	0	9
4:30 PM	4:45 PM	8	278	0	0	289	9	2	0	7	11	0	12
4:45 PM	5:00 PM	2	206	1	1	305	9	2	0	6	7	0	9
5:00 PM	5:15 PM	6	294	1	2	284	14	0	0	4	7	0	14
5:15 PM	5:30 PM	6	247	0	0	314	6	1	0	4	8	0	3
5:30 PM	5:45 PM	4	186	1	1	215	8	0	0	5	9	0	2
5:45 PM	6:00 PM	3	130	1	2	269	6	0	0	1	9	0	4
4X Peak 15-Min. Vol. (PM)		24	1176	4	8	1136	56	0	0	16	28	0	56
% of Total Traffic		1.0%	47.0%	0.2%	0.3%	45.4%	2.2%	0.0%	0.0%	0.6%	1.1%	0.0%	2.2%
% Directional			48.1%			47.9%	Intersection		0.6%			3.4%	

Traffic Count Data Sheet

Year Counts Taken: **2024**

E-W Street **Mountain Rd.**

N-S Street: **Woodward Pl.**

Speed Limit (Mountain Rd.)= **30**

Speed Limit (Woodward Pl.)= **30**

Unsignalized

4/18/24

Begin Time	End Time	Eastbound (Mountain Rd.)			Westbound (Mountain Rd.)			Northbound (Woodward Pl.)			Southbound (Woodward Pl.)		
		L	T	R	L	T	R	L	T	R	L	T	R
7:00 AM	7:15 AM	0	10	4	19	20	0	1	0	6	0	0	0
7:15 AM	7:30 AM	0	28	6	11	45	0	2	0	10	0	0	0
7:30 AM	7:45 AM	0	35	6	23	58	0	1	0	7	0	0	0
7:45 AM	8:00 AM	0	33	9	29	66	0	7	0	8	0	0	0
8:00 AM	8:15 AM	0	32	3	27	77	0	6	0	11	0	0	0
8:15 AM	8:30 AM	0	44	12	25	121	0	11	0	13	0	0	0
8:30 AM	8:45 AM	0	56	8	12	67	0	2	0	6	0	0	0
8:45 AM	9:00 AM	0	22	6	13	35	0	4	0	5	0	0	0
4X Peak 15-Min. Vol. (AM)		0	176	48	100	484	0	44	0	52	0	0	0
% of Total Traffic		0.0%	19.5%	5.3%	11.1%	53.5%	0.0%	4.9%	0.0%	5.8%	0.0%	0.0%	0.0%
% Directional			24.8%			64.6%	Intersection		10.6%			0.0%	

Begin Time	End Time	Eastbound (Mountain Rd.)			Westbound (Mountain Rd.)			Northbound (Woodward Pl.)			Southbound (Woodward Pl.)		
		L	T	R	L	T	R	L	T	R	L	T	R
4:00 PM	4:15 PM	0	66	8	7	54	0	7	0	7	0	0	0
4:15 PM	4:30 PM	0	40	4	10	37	0	9	0	15	0	0	0
4:30 PM	4:45 PM	0	29	2	5	35	0	2	0	17	0	0	0
4:45 PM	5:00 PM	0	32	3	7	32	0	4	0	29	0	0	0
5:00 PM	5:15 PM	0	42	3	6	42	0	11	0	27	0	0	0
5:15 PM	5:30 PM	0	29	1	6	88	0	17	0	24	0	0	0
5:30 PM	5:45 PM	0	20	3	6	53	0	9	0	11	0	0	0
5:45 PM	6:00 PM	0	12	1	5	41	0	15	0	11	0	0	0
4X Peak 15-Min. Vol. (PM)		0	116	4	24	352	0	68	0	96	0	0	0
% of Total Traffic		0.0%	17.6%	0.6%	3.6%	53.3%	0.0%	10.3%	0.0%	14.5%	0.0%	0.0%	0.0%
% Directional			18.2%			57.0%	Intersection		24.8%			0.0%	

Traffic Count Data Sheet

Year Counts Taken:

2024

E-W Street **Mountain Rd.**
 N-S Street: **AHS W. Driveway**
 Unsignalized

Speed Limit (Mountain Rd.)= **30**
 Speed Limit (AHS W. Driveway)= **30**
4/18/24

Begin Time	End Time	Eastbound (Mountain Rd.)			Westbound (Mountain Rd.)			Northbound (AHS W. Driveway)			Southbound (AHS W. Driveway)		
		L	T	R	L	T	R	L	T	R	L	T	R
7:00 AM	7:15 AM	1	19	0	0	22	4	0	0	0	2	0	0
7:15 AM	7:30 AM	3	25	0	0	40	12	0	0	0	5	0	3
7:30 AM	7:45 AM	3	30	0	0	33	11	0	0	0	13	0	3
7:45 AM	8:00 AM	5	31	0	0	55	9	0	0	0	6	0	5
8:00 AM	8:15 AM	17	25	0	0	54	19	0	0	0	11	0	6
8:15 AM	8:30 AM	25	41	0	0	60	59	0	0	0	12	0	27
8:30 AM	8:45 AM	19	48	0	0	58	51	0	0	0	27	0	27
8:45 AM	9:00 AM	4	33	0	0	37	1	0	0	0	4	0	5
4X Peak 15-Min. Vol. (AM)		76	192	0	0	232	204	0	0	0	108	0	108
% of Total Traffic		8.3%	20.9%	0.0%	0.0%	25.2%	22.2%	0.0%	0.0%	0.0%	11.7%	0.0%	11.7%
% Directional			29.1%			47.4%	Intersection		0.0%			23.5%	

Begin Time	End Time	Eastbound (Mountain Rd.)			Westbound (Mountain Rd.)			Northbound (AHS W. Driveway)			Southbound (AHS W. Driveway)		
		L	T	R	L	T	R	L	T	R	L	T	R
3:00 PM	3:15 PM	1	28	0	0	49	3	0	0	0	1	0	3
3:15 PM	3:30 PM	1	27	0	0	50	5	0	0	0	0	0	3
3:30 PM	3:45 PM	10	34	0	0	46	14	0	0	0	3	0	9
3:45 PM	4:00 PM	5	33	0	0	58	11	0	0	0	50	0	46
4:00 PM	4:15 PM	2	30	0	0	45	4	0	0	0	10	0	8
4:15 PM	4:30 PM	3	31	0	0	52	4	0	0	0	4	0	3
4:30 PM	4:45 PM	2	27	0	0	71	6	0	0	0	0	0	4
4:45 PM	5:00 PM	0	41	0	0	62	4	0	0	0	3	0	4
5:00 PM	5:15 PM	0	34	0	0	74	5	0	0	0	6	0	1
5:15 PM	5:30 PM	1	28	0	0	54	2	0	0	0	0	0	0
5:30 PM	5:45 PM	0	27	0	0	55	0	0	0	0	0	0	1
5:45 PM	6:00 PM	0	20	0	0	52	0	0	0	0	2	0	1
4X Peak 15-Min. Vol. (PM)		20	132	0	0	232	44	0	0	0	200	0	184
% of Total Traffic		2.5%	16.3%	0.0%	0.0%	28.6%	5.4%	0.0%	0.0%	0.0%	24.6%	0.0%	22.7%
% Directional			18.7%			34.0%	Intersection		0.0%			47.3%	

Traffic Count Data Sheet

Year Counts Taken: **2024**

E-W Street **Mountain Rd.**
N-S Street: **AHS Cntr Drvwy**

Unsignalized

Speed Limit (Mountain Rd.)= **30**
Speed Limit (AHS Cntr Drvwy)= **30**
4/18/24

Begin Time	End Time	Eastbound (Mountain Rd.)			Westbound (Mountain Rd.)			Northbound (AHS Cntr Drvwy)			Southbound (AHS Cntr Drvwy)		
		L	T	R	L	T	R	L	T	R	L	T	R
7:00 AM	7:15 AM	0	13	0	0	36	0	0	0	0	0	0	0
7:15 AM	7:30 AM	0	40	0	0	53	0	0	0	0	0	0	0
7:30 AM	7:45 AM	0	43	0	0	83	0	0	0	0	0	0	0
7:45 AM	8:00 AM	0	42	0	0	95	0	0	0	0	0	0	0
8:00 AM	8:15 AM	0	42	0	0	104	0	0	0	0	0	0	0
8:15 AM	8:30 AM	0	57	0	0	141	0	0	0	0	0	0	0
8:30 AM	8:45 AM	0	65	0	0	79	0	0	0	0	2	0	2
8:45 AM	9:00 AM	0	27	0	0	47	0	0	0	0	0	0	0
4X Peak 15-Min. Vol. (AM)		0	228	0	0	564	0	0	0	0	0	0	0
% of Total Traffic		0.0%	28.8%	0.0%	0.0%	71.2%	0.0%	0.0%	0.0%	0.0%	0.0%	0.0%	0.0%
% Directional			28.8%			71.2%	Intersection					0.0%	

Begin Time	End Time	Eastbound (Mountain Rd.)			Westbound (Mountain Rd.)			Northbound (AHS Cntr Drvwy)			Southbound (AHS Cntr Drvwy)		
		L	T	R	L	T	R	L	T	R	L	T	R
3:00 PM	3:15 PM	0	42	0	0	60	0	0	0	0	9	0	3
3:15 PM	3:30 PM	0	33	0	0	59	0	0	0	0	0	0	0
3:30 PM	3:45 PM	0	52	0	0	54	0	0	0	0	0	0	0
3:45 PM	4:00 PM	0	90	0	0	70	0	0	0	0	1	0	1
4:00 PM	4:15 PM	0	50	0	0	59	0	0	0	0	0	0	0
4:15 PM	4:30 PM	0	46	0	0	38	0	0	0	0	0	0	0
4:30 PM	4:45 PM	0	54	0	0	35	0	0	0	0	0	0	0
4:45 PM	5:00 PM	0	61	0	0	45	0	0	0	0	0	0	0
5:00 PM	5:15 PM	0	76	0	0	75	0	0	0	0	6	0	1
5:15 PM	5:30 PM	0	36	0	0	70	0	0	0	0	1	0	0
5:30 PM	5:45 PM	0	25	0	0	56	0	0	0	0	0	0	0
5:45 PM	6:00 PM	0	17	0	0	40	0	0	0	0	0	0	0
4X Peak 15-Min. Vol. (PM)		0	360	0	0	280	0	0	0	0	4	0	4
% of Total Traffic		0.0%	55.6%	0.0%	0.0%	43.2%	0.0%	0.0%	0.0%	0.0%	0.6%	0.0%	0.6%
% Directional			55.6%			43.2%	Intersection					1.2%	

Traffic Count Data Sheet

Year Counts Taken: **2024**

E-W Street **Embassy Drvy**

N-S Street: **Woodward Pl.**

Speed Limit (Embassy Drvy)= **30**

Speed Limit (Woodward Pl.)= **30**

Unsignalized

4/18/24

Begin Time	End Time	Eastbound (Embassy Drvy)			Westbound (Embassy Drvy)			Northbound (Woodward Pl.)			Southbound (Woodward Pl.)		
		L	T	R	L	T	R	L	T	R	L	T	R
7:00 AM	7:15 AM	0	0	0	0	0	0	3	6	1	0	1	1
7:15 AM	7:30 AM	1	0	0	0	0	1	3	4	3	8	9	1
7:30 AM	7:45 AM	1	0	0	2	0	0	2	10	3	12	11	0
7:45 AM	8:00 AM	0	0	1	1	0	1	1	8	7	18	11	1
8:00 AM	8:15 AM	0	0	1	0	0	4	4	11	3	21	12	4
8:15 AM	8:30 AM	3	0	2	2	0	2	7	17	3	11	10	4
8:30 AM	8:45 AM	0	1	0	0	0	1	6	12	0	12	9	4
8:45 AM	9:00 AM	2	0	2	0	0	3	2	8	0	5	4	3
4X Peak 15-Min. Vol. (AM)		12	0	8	8	0	8	28	68	12	44	40	16
% of Total Traffic		4.9%	0.0%	3.3%	3.3%	0.0%	3.3%	11.5%	27.9%	4.9%	18.0%	16.4%	6.6%
% Directional			8.2%			6.6%	Intersection		44.3%			41.0%	

Begin Time	End Time	Eastbound (Embassy Drvy)			Westbound (Embassy Drvy)			Northbound (Woodward Pl.)			Southbound (Woodward Pl.)		
		L	T	R	L	T	R	L	T	R	L	T	R
4:00 PM	4:15 PM	14	0	8	3	0	6	0	9	1	1	8	0
4:15 PM	4:30 PM	11	0	0	1	0	5	0	11	0	2	1	0
4:30 PM	4:45 PM	13	0	4	1	0	8	1	14	3	8	3	0
4:45 PM	5:00 PM	13	0	2	1	0	5	0	14	0	3	9	0
5:00 PM	5:15 PM	12	0	2	5	0	14	0	21	1	1	5	1
5:15 PM	5:30 PM	8	0	2	0	0	2	0	12	0	1	7	1
5:30 PM	5:45 PM	0	0	0	0	0	2	0	21	0	0	3	0
5:45 PM	6:00 PM	0	0	0	1	0	0	0	17	0	1	6	0
4X Peak 15-Min. Vol. (PM)		48	0	8	20	0	56	0	84	4	4	20	4
% of Total Traffic		19.4%	0.0%	3.2%	8.1%	0.0%	22.6%	0.0%	33.9%	1.6%	1.6%	8.1%	1.6%
% Directional			22.6%			30.6%	Intersection		35.5%			11.3%	

**Crash Database from NM DOT Safety Bureau
Mountain Rd. / Edith Blvd.
(2018 through 2022)**

	CRASH REPORT NUMBER	CRASH DATE	TIME OF CRASH	DAY OF WEEK	PRIMARY STREET	SECONDARY STREET	CRASH DIRECTION	DIRECTION FROM INTERSECTION OR LANDMARK	DISTANCE FROM LANDMARK	DISTANCE FROM LANDMARK MEASUREMENT UNIT	CRASH SEVERITY	CRASH ANALYSIS	FIRST HARMFUL EVENT - MANNER OF CRASH	ALCOHOL INVOLVEMENT	PEDESTRIAN INVOLVEMENT
	23461713	11/8/2019	7:15	Friday	807 MOUNTAIN RD NE	N/A					PDO Crash	Left Blank	Not Available	Not Involved	Not Involved
Corridor 2	710560304	5/8/2019	15:54	Wed	MOUNTAIN RD NE	WALTER ST NE	E				PDO Crash	Other Vehicle - Both Going Straight/Entering At Angle	Not Available	Not Involved	Not Involved
	30289106	4/21/2022	8:00	Thurs	807 MOUNTAIN RD NE		W				PDO Crash	Left Blank	Intersecting Path (T-bone)	Not Involved	Not Involved
Intersectoin #1	23468079	7/23/2019	12:10	Tuesday	EDITH	MOUNTAIN	N				PDO Crash	Left Blank	Not Available	Not Involved	Not Involved
	710766201	8/27/2020	15:51	Thurs	MOUNTAIN RD NE	EDITH BLVD NE	W				Injury Crash	Left Blank	From Opposite Direction	Not Involved	Not Involved
	710584999	9/17/2021	10:49	Friday	EDITH BLVD NE NM 98	MOUNTAIN RD NE	S				Injury Crash	Left Blank	Intersecting Path (T-bone)	Not Involved	Not Involved
	710802971	11/7/2021	15:49	Sunday	EDITH BLVD NE NM 98	MOUNTAIN RD NE	N				PDO Crash	Left Blank	From Opposite Direction	Not Involved	Not Involved
	710881002	2/2/2022	17:45	Wed	EDITH BLVD NE	MOUNTAIN RD	S	N	8	FT	PDO Crash	Left Blank	From Same Direction	Not Involved	Not Involved
	710907255	10/14/2022	23:32	Friday	MOUNTAIN RD	EDITH BLVD	E	E			PDO Crash	Left Blank	Intersecting Path (T-bone)	Not Involved	Not Involved
	710913277	8/30/2022	8:14	Tuesday	EDITH BLVD NE NM 98	MOUNTAIN RD NE	N	N	50	FT	PDO Crash	Left Blank	Left Blank	Not Involved	Not Involved
Intersectoin #3	710368022	2/17/2018	10:27	Sat	FRONTAGE RD	MOUNTAIN RD NE	S				Injury Crash	Other Vehicle - Both Going Straight/Entering At Angle	Not Available	Not Involved	Not Involved
	710443347	3/23/2018	7:30	Friday	I25 SB FRONTAGE RD	MOUNTAIN RD NE	S				PDO Crash	Other Vehicle - From Same Direction/Vehicle Backing	Not Available	Not Involved	Not Involved
	710445308	1/14/2018	14:36	Sunday	MOUNTAIN AVE	LOCUST AVE	W				Injury Crash	Other Vehicle - Both Going Straight/Entering At Angle	Not Available	Not Involved	Not Involved
	710452849	9/19/2018	14:35	Wed	MOUNTAIN RD		N				Injury Crash	Other Vehicle - Both Going Straight/Entering At Angle	Not Available	Not Involved	Not Involved
	710542176	7/14/2018	7:17	Sat	MOUNTAIN RD NE	LOCUST ST NE	W	W			PDO Crash	Other Vehicle - From Opposite Direction/Both Going Straight	Not Available	Not Involved	Not Involved
	710544575	6/22/2018	8:36	Friday	MOUNTAIN RD NE	S/B FRONTAGE RD NE	SW				Injury Crash	Other Vehicle - One Left Turn/Entering At Angle	Not Available	Not Involved	Not Involved
	710553534	11/10/2018	8:31	Sat	LOCUST ST NE	MOUNTAIN RD NE	S				Injury Crash	Other Vehicle - From Opposite Direction/Both Going Straight	Not Available	Not Involved	Not Involved
	23467020	6/20/2019	15:59	Thurs	FRONTAGE RD NORTH	MOUNTAIN RD	N				PDO Crash	Left Blank	Not Available	Not Involved	Not Involved
	23481599	4/20/2019	17:30	Sat	MOUNTAIN	I-25 SOUTH	E				PDO Crash	Left Blank	Not Available	Not Involved	Not Involved
	710402777	2/19/2019	15:14	Tuesday	I 25 FRONTAGE RD	MOUNTAIN RD NE	S				PDO Crash	Other Vehicle - Both Going Straight/Entering At Angle	Not Available	Not Involved	Not Involved
	710457248	1/20/2019	13:45	Sunday	FRONTAGE RD	MOUNTAIN RD	N	S	0	FT	Injury Crash	Other Vehicle - From Opposite Direction/One Left Turn	Not Available	Not Involved	Not Involved
	710558829	1/16/2019	9:33	Wed	I25 SB FRONTAGE RD NE	MOUNTAIN RD NE	S				PDO Crash	Other Vehicle - One Right Turn/Entering At Angle	Not Available	Not Involved	Not Involved
	710563246	3/14/2019	7:50	Thurs	PAN AMERICAN WEST HY NE		S	N	50	FT	Injury Crash	Other Vehicle - From Same Direction/Both Going Straight	Not Available	Not Involved	Not Involved
	710563770	4/12/2019	13:25	Friday	MOUNTAIN RD NE	SOUTH FRONTAGE RD	E				Injury Crash	Other Vehicle - From Opposite Direction	Not Available	Not Involved	Not Involved
	710565932	10/5/2019	7:49	Sat	FRONTAGE RD NE		S	N	250	FT	PDO Crash	Other Vehicle - From Same Direction/Rear End Collision	Not Available	Not Involved	Not Involved
	710570258	9/7/2019	14:43	Sat	PAN AMERICAN FWY SOUTH	MOUNTAIN RD NE	S	E	15	FT	Injury Crash	Fixed Object - Bridge	Not Available	Not Involved	Not Involved
	710570897	9/9/2019	10:56	Monday	LOCUST ST	MOUNTAIN RD NE	S				PDO Crash	Other Vehicle - Both Going Straight/Entering At Angle	Not Available	Not Involved	Not Involved
	30261843	2/2/2020	N/A	Sunday		WYOMING BLVD NE	E				PDO Crash	Left Blank	Left Blank	Not Involved	Not Involved
	30262149	2/20/2020	6:20	Thurs		S FRONTAGE RD & MOUNTAIN RD					PDO Crash	Invalid Code	Left Blank	Not Involved	Not Involved
	30281696	11/25/2020	11:10	Wed	FRNTG AND MOUNTAIN NE	FRONTAGE AND MOUNTAIN	S				PDO Crash	Invalid Code	Left Blank	Not Involved	Not Involved
	710553087	12/30/2020	18:43	Wed	I 25 SOUTH-BD FW	MOUNTAIN RD NE	S	S			PDO Crash	Left Blank	Intersecting Path (T-bone)	Not Involved	Not Involved
	710580111	12/15/2020	21:34	Tuesday	LOCUST ST NE	MOUNTAIN RD NE	S				PDO Crash	Left Blank	Intersecting Path (T-bone)	Not Involved	Not Involved
	30282810	2/10/2021	8:45	Wed	N. FRONTAGE RD.	MOUNTAIN RD NE	N				PDO Crash	Other Vehicle - From Opposite Direction	Left Blank	Not Involved	Not Involved
	30310690	12/5/2021	17:54	Sunday	PAN AMERICAN FWY NE	MOUNTAIN I-25	S				Injury Crash	Left Blank	Left Blank	Not Involved	Not Involved
	710773107	11/18/2021	22:20	Thurs	I25 NORTH FRONTAGE RD	I40 EAST FRONTAGE RD	N				Injury Crash	Left Blank	From Same Direction	Involved	Not Involved
	710786140	5/20/2021	12:27	Thurs	LOCUST ST	MOUNTAIN RD NE	S				Injury Crash	Left Blank	Intersecting Path (T-bone)	Not Involved	Not Involved
	710793349	10/15/2021	14:26	Friday	PAN AMERICAN EAST HY NE	MOUNTAIN RD NE	S				PDO Crash	Left Blank	Left Blank	Not Involved	Not Involved
	710795635	11/15/2021	16:20	Monday	LOCUST AVE	MOUNTAIN RD NE	S				PDO Crash	Left Blank	Intersecting Path (T-bone)	Not Involved	Not Involved
	710796028	9/30/2021	13:50	Thurs	MOUNTAIN RD NE	I 25 FRONTAGE RD	W				Injury Crash	Left Blank	Intersecting Path (T-bone)	Not Involved	Not Involved
	710796039	11/5/2021	19:30	Friday	I 25 FRONTAGE RD	MOUNTAIN RD NW	S				Injury Crash	Left Blank	Intersecting Path (T-bone)	Not Involved	Not Involved
	710799513	11/10/2021	17:48	Wed	I 25 FRONTAGE RD	MOUNTAIN RD NE	S				Injury Crash	Left Blank	From Same Direction	Not Involved	Not Involved
	710803498	11/4/2021	15:29	Thurs	MOUNTAIN RD	FRONTAGE RD	W	W			Injury Crash	Left Blank	Intersecting Path (T-bone)	Not Involved	Not Involved
	30311409	1/20/2022	8:35	Thurs	SOUTH FRONTAGE RD	MOUNTAIN RD	S				PDO Crash	Left Blank	Left Blank	Not Involved	Not Involved
	30325283	8/14/2022	12:15	Sunday	I-25 E FRONTAGE RD	MOUNTAIN PL	S				Injury Crash	Left Blank	From Same Direction	Not Involved	Not Involved
	30325969	11/21/2022	15:50	Monday	LOCUST ST.	MOUNTAIN RD NE					PDO Crash	Left Blank	Left Blank	Not Involved	Not Involved
	710913337	11/15/2022	17:35	Tuesday	I-25 FRONTAGE RD	MOUNTAIN RD NE	S				Injury Crash	Left Blank	Intersecting Path (T-bone)	Not Involved	Not Involved
	710914664	12/25/2022	16:08	Sunday	I-25 SOUTHBOUND FR	MOUNTAIN RD NE	S	W			Injury Crash	Left Blank	Intersecting Path (T-bone)	Not Involved	Not Involved
	710918208	11/23/2022	9:54	Wed	FRONTAGE RD	MOUNTAIN RD NE	S	S			Injury Crash	Left Blank	Intersecting Path (T-bone)	Not Involved	Not Involved

SCOPE OF TRAFFIC IMPACT STUDY (TIS)

TO: Terry Brown
Terry O. Brown, P.E.
P. O. Box 92051
Albuquerque, NM 87199-2051

MEETING DATE: Thursday, February 29, 2024 at 9:00 am.

ATTENDEES: Matthew Grush (City of Albuquerque); Margaret Haynes (NM DOT); Ron Bohannon, Jimeia Roberts, and Terry Brown (Tierra West LLC).

PROJECT: Rehabilitation Hospital (Mountain Rd. / I-25)

REQUESTED CITY ACTION: Zone Change Site Development Plan

 Subdivision Building Permit Sector Plan Sector Plan Amendment

 Curb Cut Permit Conditional Use Annexation Site Plan Amendment

ASSOCIATED APPLICATION: Description of development, where, what, etc. Include acreage, uses, etc. Proposed rehabilitation hospital facility.

SCOPE OF REPORT:

The Traffic Impact Study should follow the standard report format, which is outlined in the DPM. The following supplemental information is provided for the preparation of this specific study.

1. Trip Generation - Use Trip Generation Manual, 10th Edition.
Local data may be used for certain land use types as determined by staff.
Consultant to provide.
2. Appropriate study area:
Signalized Intersections;
 - a. Mountain Rd. / I-25 W. Frontage Rd.
 - b. Lomas Blvd. / I-25 W. Frontage Rd.
Unsignalized Intersections;
 - a. Mountain Rd. / Woodward Pl.
 - b. Mountain Rd. / Albuquerque High School driveways (3)
 - c. Woodward Pl. / Embassy Suites Hotel North Driveway
 - d. Woodward Pl. / Lomas Blvd.
Driveway Intersections: all site drives. (1)
3. Intersection turning movement counts
Study Time – 7-9 a.m. peak hour, **3:30-5:30 p.m.** peak hour (school ends at 3:40 pm)
Consultant to provide for all intersections listed above.
4. Type of intersection progression and factors to be used.
Type III arrival type (see “Highway Capacity Manual, current edition” or equivalent as approved by staff). Unless otherwise justified, peak hour factors and % heavy commercial should be taken directly from the MRCOG turning movement data provided or as calculated from current count data by consultant.

5. Boundaries of area to be used for trip distribution.
 - City Wide - residential, office or industrial;
 - 2-mile radius – commercial; (consultant to proposed preliminary trip distribution criteria for approval by City of Albuquerque.
 - Interstate or to be determined by consultant - motel/hotel
 - APS district boundary mapping for each school and bus routes

6. Basis for trip distribution.

Residential – Use inverse relationship based upon distance and employment. Use employment data from 2040 Socioeconomic Forecasts, MRCOG – See MRCOG website for most current data.

Office/Industrial - Use inverse relationship based upon distance and population. Use population data from 2040 Socioeconomic Forecasts, MRCOG – See MRCOG website for most current data.

Commercial - Use relationship based upon population. Use population data from 2040 Socioeconomic Forecasts, MRCOG – See MRCOG website for most current data.

Residential - $T_s = (T_t) (S_e / D) / (S_e / D)$
 T_s = Development to Individual Subarea Trips
 T_t = Total Trips
 S_e = Subarea Employment
 D = Distance from Development to Subarea

Office/Industrial - $T_s = (T_t) (S_p / D) / (S_p / D)$
 T_s = Development to Individual Subarea Trips
 T_t = Total Trips
 S_p = Subarea Population
 D = Distance from Development to Subarea

Commercial -
 $T_s = (T_t) (S_p) / (S_p)$
 T_s = Development to Individual Subarea Trips
 T_t = Total Trips
 S_p = Subarea Population

7. Traffic Assignment. Logical routing on the major street system.
8. Proposed developments which have been approved but not constructed that are to be Included in the analyses. Projects in the area include:
 - a. None
9. Method of intersection capacity analysis - planning or operational (see “2016 Highway Capacity Manual” or equivalent [i.e. HCS, Synchro, Teapac, etc.] as approved by staff). Must use latest version of design software and/or current edition of design manual.
 - Implementation Year: 2025
 - Horizon Year: 2035
10. Traffic conditions for analysis:
 - a. Existing analysis yes no - year (xxxx);
 - b. Phase implementation year(s) without proposed development – 2025
 - c. Phase implementation year(s) with proposed development – 2025

- d. Project horizon year without proposed development – 2035
 - e. Project horizon year with proposed development – 2035
 - f. Other –
11. Background traffic growth.
Method: use 10-year historical growth based on standard data from the MRCOG Traffic Flow Maps. Minimum growth rate to be used is 1/2%.
 12. Planned (programmed) traffic improvements.
List planned CIP improvements in study area and projected project implementation year:
 - a. Project – Location (Implementation Year)
 13. Items to be included in the study:
 - a. Intersection analysis.
 - b. Signal progression - An analysis is required if the driveway analysis indicates a traffic signal is possibly warranted. Analysis Method:
 - c. Arterial LOS analysis;
 - d. Recommended street, intersection and signal improvements.
 - e. Site design features such as turning lanes, median cuts, queuing requirements and site circulation, including driveway signalization and visibility.
 - f. Transportation system impacts.
 - g. Other mitigating measures.
 - h. Accident analyses yes no; Location(s): 5 year history (2015-2019)
 - i. Weaving analyses yes no; Location(s):
 14. Other: Safety Study for entire study area for NM DOT focused on crash rates at or near Mountain Rd. / I-25. NM DOT will supply individual crash reports for the most recent five-year period of time.

SUBMITTAL REQUIREMENTS:

1. Number of copies of report required
 - a. 1 digital copy
2. Submittal Fee – \$1300 for up to 3 reviews

The Traffic Impact Study for this development proposal, project name, shall be performed in accordance with the above criteria. If there are any questions regarding the above items, please contact me at 924-3991.

M. Grush P.E.

4/2/2024

Matt Grush, P.E.
Senior Engineer
City of Albuquerque, Planning
Transportation Development Section

Date

via: email
C: TIS Task Force Attendees, file